

General Specifications

YTA510 Temperature Transmitter



GS 01C50E01-01EN

The YTA510 is the high performance temperature transmitter that accepts Thermocouple, RTD, ohms or DC millivolt inputs. The dual input type independently measures and calculates process values for Sensor 1 and Sensor 2. YTA510 transmit not only process variables but also the setting parameters using wireless signal. In case of the battery powered type, the transmitters run on internal batteries, and the installation cost can be decreased since hard-wiring is not required. The communication is compliant with ISA100.11a protocol specifications.

■ FEATURES

● Long Life Battery Design

Ultra low current consumption design using two high capacity lithium-thionyl chloride batteries provide wireless operation for years.

● Security Assured Wireless Network Joining

Infrared communication between the devices for wireless network configuration and parameter setting.

● Quick Update Time

Selectable from 1 second to 60 minutes for measured process value to publish wirelessly.

■ STANDARD SPECIFICATIONS

■ WIRELESS SPECIFICATIONS

Communication protocol: ISA100.11a protocol
Data rate: 250 kbps
Frequency: 2400 - 2483.5 MHz license free ISM band
Radio security: AES 128 bit codified
RF Transmitter power: Max. 11.6 dBm
Antenna: +2 dBi Omni directional monopole type
Separately sold remote antenna and antenna cables can be used.

■ POWER SUPPLY SPECIFICATIONS

Battery:
Use the dedicated battery pack.
Rated voltage: 7.2 V
Rated capacity: 19 Ah
External Power Source:
Rated voltage: 10.5 to 30 V DC
Rated current: 36 mA

■ PERFORMANCE SPECIFICATIONS

Accuracy

See Table 1.

Cold Junction Compensation Accuracy

For T/C only
 $\pm 0.5^{\circ}\text{C}$ ($\pm 0.9^{\circ}\text{F}$)

Ambient Temperature Effect (per 1.0°C change)

See Table 2.



Battery Characteristic

Battery pack with long life lithium-thionyl chloride batteries. With the intrinsically safe type, the battery pack is replaceable in hazardous area. Typical battery life is 10 years at 10 seconds update time in the following conditions.*

- Ambient temperature: $23\pm 2^{\circ}\text{C}$
- Device role: IO mode
- LCD display: off
- Power saving mode: on
- Sensor input: single input

* Environmental condition such as vibration may affect the battery life.

■ FUNCTIONAL SPECIFICATIONS

Input

Input type is selectable: Thermocouples, 2-, 3-, and 4-wire RTDs, ohms and DC millivolts. See Table 1. 4-wire is available for Sensor 1 input.

Input Signal Source Resistance (for T/C, mV)

1 k Ω or lower

Input Lead Wire Resistance (for RTD, Ohm)

10 Ω per wire or lower

Output

Wireless (ISA100.11a protocol) 2.4 GHz signal.

Range

See Table 1.

Update Period

1 to 3600 s selectable.*

* Minimum update time is 2 s at dual input sensor use.

Zero-gain Adjustment

Set the amount of zero-gain point adjustment.

Integral Indicator (LCD display)

5-digit numerical display, unit display and bar graph. The indicator is configurable to display the following variables periodically.
°C, K, °F, °R, mV and ohm, 0 to 100 % bar graph, and alternate display of Sensor 1 and Sensor 2 process value
See also "Factory Setting."

Sensor Burnout

Select either HIGH or LOW as the configuration.

Self Diagnostics

Amplifier failure, sensor failure, configuration error, battery alarm, wireless communication alarm and over-range error for process variables.

Software Download Function

Software download function permits to update wireless field device software via ISA100.11a wireless communication.

Battery Pack

2x primary lithium-thionyl chloride batteries with battery case (batteries sold separately)

■ **NORMAL OPERATING CONDITION**

(Optional features or approval codes may affect limits.)

Ambient Temperature Limits

-40 to 85°C (-40 to 185°F)
-30 to 80°C (-22 to 176°F) LCD visible range

Ambient Humidity Limits

0 to 100% RH

■ **REGULATORY COMPLIANCE STATEMENTS**

This device contains the wireless module which satisfies the following standards.

- * The specific radio equipment (Approval Number:007WWCUL0480) which received the technical standard satisfied certification based on the Radio Law is used for this product.
- * Please confirm that an installation region fulfills an applicable standard. If additional regulatory information and approvals are required, contact a Yokogawa representative.

EMC Conformity Standards

EN61326-1 Class A, Table 2 (For use in industrial locations), EN61326-2-3

Radio Equipment Directive (RE)

EN 300 328, EN 301 489-1, EN 301 489-17, EN61010-1, EN61010-2-030, EN62311
• Indoor/Outdoor use

EU RoHS Directive

EN IEC 63000

Safety Requirement Standards

EN61010-1, EN61010-2-030
• Installation category: I (Anticipated transient overvoltage 330 V)
• Pollution degree: 2
• Indoor/Outdoor use

Regulation Conformity of the Wireless Module

- FCC Approval
- ISED Approval

■ **PHYSICAL SPECIFICATIONS**

Enclosure

Housing

Low copper cast aluminum alloy

Coating of housing

[for aluminum housing]
Polyester resin powder coating
Mint-green paint (Munsell 5.6BG 3.3/2.9 or its equivalent)
[for option code /P□ or /X2]
Epoxy and polyurethane resin solvent coating

Degrees of Protection

IP66/IP67, Type 4X

Name plate and tag

316 SST tag plate wired onto transmitter.

Weight

2.8 kg (6.2 lb)*
* The weight does not include that of battery pack and mounting bracket.
Add 0.3kg for the external powered type.

Connections

Refer to "MODEL AND SUFFIX CODE."

< **Related Instruments** >

- Field Wireless System:
Refer to GS 01W01A01-01EN
- Field Wireless Management Station YFGW410:
GS 01W02D01-01EN
- Field Wireless Access Point YFGW510:
GS 01W02E01-01EN
- Field Wireless Access Point YFGW520:
GS 01W02E02-01EN
- Field Wireless Media Converter YFGW610:
GS 01W02D02-01EN

Table 1. Sensor type, measurement range, and accuracy

Sensor Type		Standard	Measurement Range	Accuracy
T/C	B	IEC584	100 to 300°C (212 to 572°F)	± 5.0°C (± 9.0°F)
			300 to 400°C (572 to 752°F)	± 2.0°C (± 3.6°F)
			400 to 1820°C (752 to 3308°F)	± 1.5°C (± 2.7°F)
	E		-200 to 1000°C (-328 to 1832°F)	± 0.4°C (± 0.8°F)
	J		-200 to 1200°C (-328 to 2192°F)	± 0.5°C (± 0.9°F)
	K		-200 to 1372°C (-328 to 2502°F)	± 0.6°C (± 1.1°F)
	N		-200 to 1300°C (-328 to 2372°F)	± 0.6°C (± 1.1°F)
	R		-50 to 100°C (-58 to 212°F)	± 1.7°C (± 3.1°F)
			100 to 1768°C (212 to 3214°F)	± 0.8°C (± 1.5°F)
	S		-50 to 100°C (-58 to 212°F)	± 1.7°C (± 3.1°F)
100 to 1768°C (212 to 3214°F)		± 0.8°C (± 1.5°F)		
T	-200 to 400°C (-328 to 752°F)	± 0.5°C (± 0.9°F)		
RTD	Pt100	IEC751	-200 to 850°C (-328 to 1562°F)	± 0.3°C (± 0.6°F)
	Pt200		-200 to 850°C (-328 to 1562°F)	± 0.6°C (± 1.1°F)
	Pt500		-200 to 850°C (-328 to 1562°F)	± 0.5°C (± 0.9°F)
mV		-	-10 to 220 [mV]	± 0.03 [mV]
Ohm		-	0 to 2000 [Ω]	± 1 [Ω]

Note: For T/C input, add Cold Junction Compensation Accuracy (± 0.5°C) to the total accuracy.
 For RTD input of the 2-wire connection, add a corrected value (± 0.1°C) to the total accuracy.

Table 2. Effects of ambient temperature

Sensor Type		Temperature Effects per 1.0°C Change in Ambient Temperature	Measurement Range
T/C	B	0.2°C - (0.066% of (t - 100))	100°C ≤ t < 300°C
		0.07°C - (0.0057% of (t - 300))	300°C ≤ t < 1000°C
		0.037°C	t ≥ 1000°C
	E	0.0035°C - (0.00492% of t)	t < 0°C
		0.0035°C + (0.00146% of t)	t ≥ 0°C
	J	0.0039°C - (0.00529% of t)	t < 0°C
		0.0039°C + (0.00149% of t)	t ≥ 0°C
	K	0.00521°C - (0.00707% of t)	t < 0°C
		0.00521°C + (0.00182% of t)	t ≥ 0°C
	N	0.0077°C - (0.00918% of t)	t < 0°C
		0.0077°C + (0.00136% of t)	t ≥ 0°C
	R, S	0.04°C - (0.057% of t)	t < 0°C
		0.04°C + (0.0102% of t)	0°C ≤ t < 100°C
		0.0316°C - (0.001% of t)	100°C ≤ t < 600°C
0.0175°C + (0.00173% of t)		t ≥ 600°C	
T	0.00513°C - (0.00631% of t)	t < 0°C	
	0.00513°C + (0.0008% of t)	t ≥ 0°C	
RTD	Pt100	0.0048°C + (0.0016% of absolute value t)	Entire Sensor Input Range
		0.0038°C + (0.0015% of absolute value t)	t < 650°C
	Pt200	0.0028°C + (0.0016% of t)	t ≥ 650°C
		0.003°C + (0.0014% of absolute value t)	t < 650°C
Pt500	0.002°C + (0.0016% of t)	t ≥ 650°C	
	mV		0.2 μV + (0.0015% of reading)
Ohm		0.001 Ω + (0.0011% of reading)	Entire Sensor Input Range

Note1: The "t" on Table 2 means the value of the reading in °C.
 Note2: The "absolute value t" on Table 2 means the absolute value of the reading in °C.
 [Example of absolute value t]
 When the temperature value is 250 Kelvin, abs reading is 23.15, absolute (250 - 273.15).

MODEL AND SUFFIX CODES

Model	Suffix Codes	Descriptions
YTA510	Temperature Transmitter
Output Signal	-1	Wireless communication (ISA100.11a protocol); successor of code -L
Amplifier Housing	8	Dual input type, cast aluminum alloy with detachable antenna (2 dBi) ^{*1}
	9	Dual input type, cast aluminum alloy without antenna (N connector) ^{*2*1}
Electrical Connection	0	G 1/2 female, two electrical connections without blind plugs
	2	1/2 NPT female, two electrical connections without blind plugs
	4	M20 female, two electrical connections without blind plugs
	5	G 1/2 female, two electrical connections with a blind plug
	7	1/2 NPT female, two electrical connections with a blind plug
	9	M20 female, two electrical connections with a blind plug
	A	G 1/2 female, two electrical connections with a 316SST blind plug
	C	1/2 NPT female, two electrical connections with a 316SST blind plug
	D	M20 female, two electrical connections with a 316SST blind plug
Integral Indicator	D	with digital indicator
Mounting Bracket	B	304 SST stainless steel 2-inch horizontal pipe mounting bracket ^{*3}
	D	304 SST stainless steel 2-inch vertical pipe mounting bracket ^{*3}
	J	316 SST stainless steel 2-inch horizontal pipe mounting bracket ^{*3}
	K	316 SST stainless steel 2-inch vertical pipe mounting bracket ^{*3}
	N	None
Power Supply	A	Battery powered type (battery case only;battery cells not included)
	B	External powered type
---	A	Always A
Option codes		/□ Optional specifications

*1: Remote antenna cables can be attached. Order separately from accessory option.

*2: Order the antenna separately from accessory option.

*3: For flat-panel mounting, please prepare bolts and nuts.

OPTIONAL SPECIFICATION

Item	Description		Code
Painting	Color change	Amplifier cover only Munsell code; N1.5, black	P□
	Coating change	High anti-corrosion coating	X2
Calibration unit	°F or °R		D2

OPTIONAL SPECIFICATION (For Explosion Protected type)

Please select appropriate equipment in accordance with the laws and regulations of the relevant country/region, when it is used in a location where explosive atmospheres may be present.

Item	Description	Code
Factory Mutual (FM)	FM Intrinsically safe Approval Applicable Standard: Class 3600:2011, Class 3610:2015, Class 3611:2016, Class 3810:2005, ANSI/UL-60079-0-2013, ANSI/UL-60079-11-2014, NEMA-250:2003 Intrinsically Safe for Class I, Division 1, Groups A, B, C & D, Class II, Division 1, Groups E, F & G and Class III, Division 1, Class I, Zone 0, in Hazardous Locations, AEx ia IIC Nonincendive for Class I, Division 2, Groups A, B, C & D, Class II, Division 2, Groups F & G and Class III, Division 1, Class I, Zone 2, Group IIC, in Hazardous Locations Enclosure: Type 4X, Temp. Class: T4, Amb. Temp.: -50 to 70°C (-58 to 158°F) Sensor Circuit Parameter: Voc=6.6 V, Isc=66 mA, Po=109 mW, Ca=22 uF, La=8.1 mH	FS17*1
ATEX	ATEX Intrinsically safe Approval Applicable Standard: EN IEC 60079-0, EN 60079-11, EN 60079-28 Certificate: KEMA 10ATEX0163 X II 1 G Ex ia op is IIC T4 Ga Degree of protection: IP66/IP67 Ambient temperature: -50°C ≤ Ta ≤ +70°C (-58°F ≤ Ta ≤ +158°F) Sensor Circuit Parameter: Uo=6.6 V, Io=66 mA, Po=109 mW, Co=22 uF, Lo=8.1 mH	KS27*1
Canadian Standards Association (CSA)	CSA Intrinsically safe Approval No. CSA10CA2328785X Applicable standard: CAN/CSA-C22.2 No.94, C22.2 No.213, CAN/CSA-C22.2 No.61010-1, CAN/CSA-C22.2 No.60079-0, CAN/CSA-C22.2 No.60079-11, CAN/CSA-C22.2 No.60529 Ex ia IIC T4 Ga Intrinsically Safe for Class I, Division 1, Groups A, B, C & D, Class II, Division 1, Groups E, F & G, Class III, Division 1, Nonincendive for Class I, Division 2, Groups A, B, C & D, Class II, Division 2, Groups F & G, Class III, Division 1 Enclosure: IP66/IP67 and Type 4X , Temperature Code: T4 Amb. Temp(Tamb): -50 to 70°C (-58 to 158°F) Sensor Circuit Parameter: Uo=6.6 V, Io=66 mA, Po=109 mW, Co=22 uF, Lo=8.1 mH	CS17*1
IECEx	IECEx Intrinsically safe Approval Applicable Standard: IEC 60079-0, IEC 60079-11, IEC 60079-28 Certificate: IECEx KEM 10.0073 X Ex ia op is IIC T4 Ga Enclosure: IP66/IP67 Ambient temperature: -50°C ≤ Ta ≤ +70°C (-58°F ≤ Ta ≤ +158°F) Sensor Circuit Parameter: Uo=6.6 V, Io=66 mA, Po=109 mW, Co=22 uF, Lo=8.1 mH	SS27*1

*1: Only applicable for selecting Power Supply code A.

OPTIONAL ACCESSORIES

Product	Part number	Specification
Battery pack assembly	F9915NQ*1	Battery case, Lithium-thionyl chloride batteries 2 pieces
Batteries*2	F9915NR	Lithium-thionyl chloride batteries, 2 pieces
Battery case	F9915NK*3	Battery case only
Remote antenna cable	F9915KU	3 m with mounting bracket
	F9915KV	13 m (3 m+10 m), with a surge protective device and mounting bracket
Antenna	F9915KW	2 dBi standard antenna
	F9915KY	6 dBi high gain antenna*4*5

- *1: If you need F9915MA, please purchase F9915NQ. F9915NQ is a set of F9915MA and instruction manual.
- *2: Alternatively, Tadiran SL-2780/S, TL-5930/S or VITZROCELL SB-D02 batteries can be purchased from your local distributor.
- *3: If you need F9915NS, please purchase F9915NK. F9915NK is a set of F9915NS and instruction manual.
- *4: Use of high gain antenna is limited by local regulation of radio and telecommunication law. Consult Yokogawa for details.
- *5: F9915KY can not connect directly to the transmitter. Remote antenna cable is required to use F9915KY.

DIMENSIONS

2-inch horizontal pipe mounting

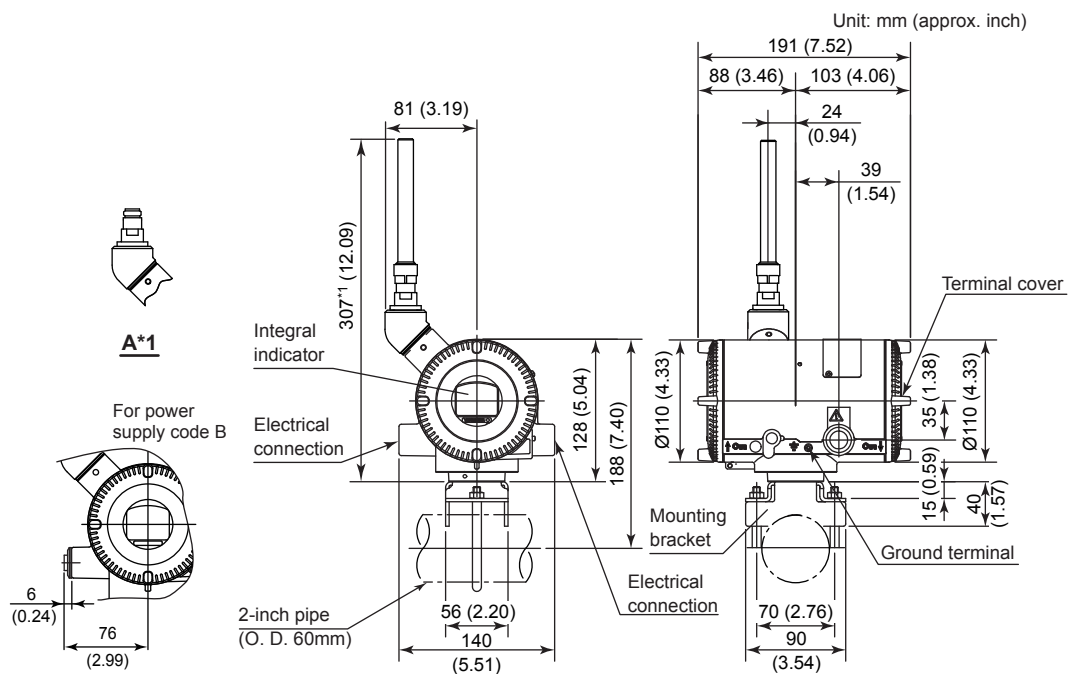

- *1: When amplifier housing code 9 is selected, the value is 187 mm (7.36 inch). In this case, the figure is shown as A.

• 2-inch vertical pipe mounting

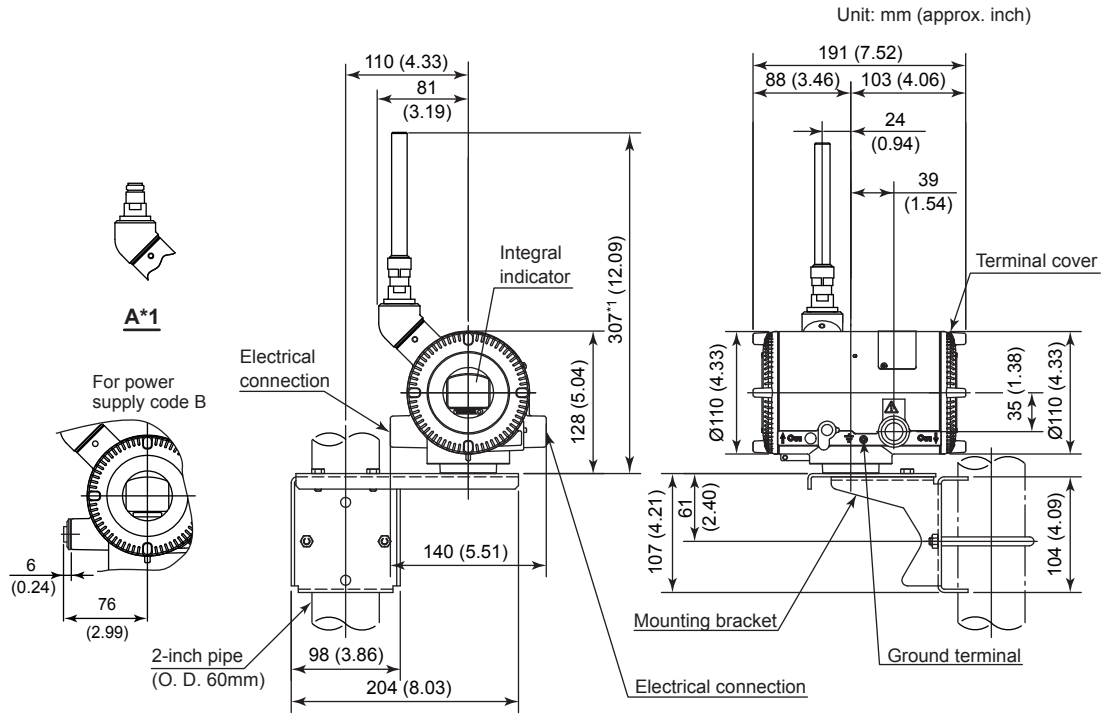

F02.ai

• Infrared Configuration

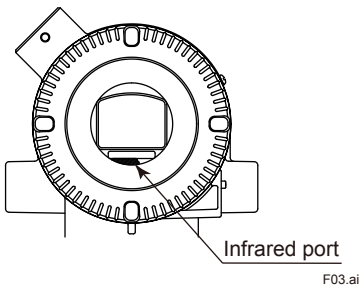

• Terminal Configuration

• Battery powered type

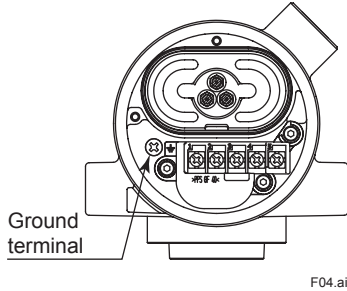

• External powered type

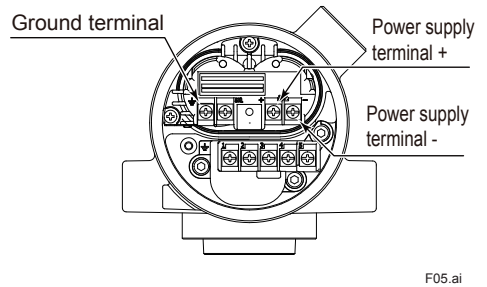

Unit: mm (approx. inch)

● Antenna/Cable

□ Non-directional antenna

• Gain: 2 dBi

Part number: F9915KW

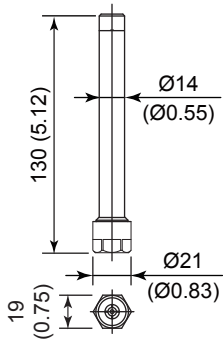

• Gain: 6 dBi

Part number: F9915KY

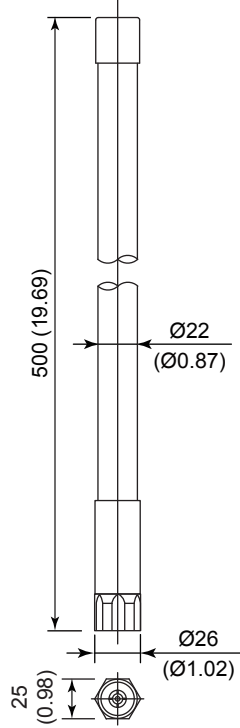

□ Antenna cable

• Sheath diameter: 11.2 mm

< Without a surge protective device >

Part number: F9915KU

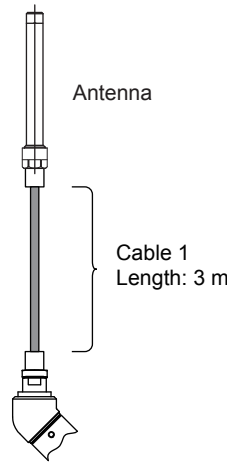

Transmitter body

< With a surge protective device >

Part number: F9915KV

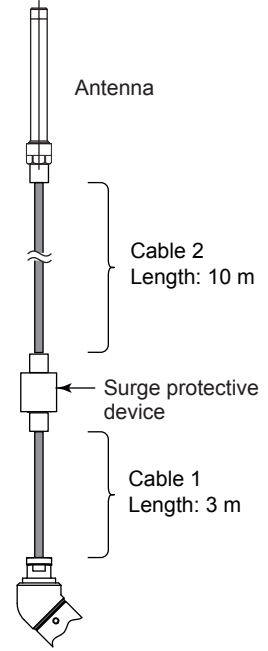

Transmitter body

● Antenna mounting bracket

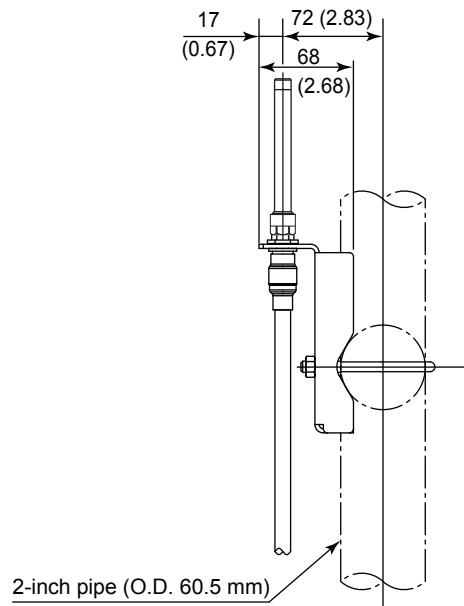
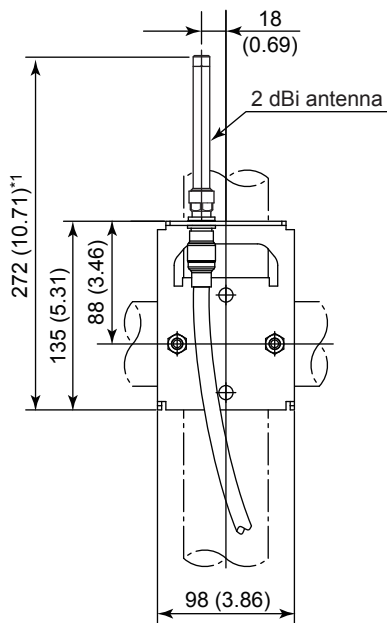

*1: When 6 dBi antenna is selected, the value is 642 mm (25.28 inch).

F06.ai

• Terminal Wiring Example for the External Power Source Terminal

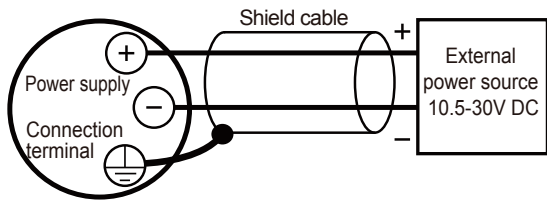

Use shield cables if it is affected by electrical noise.

F07.ai

• Input Wiring

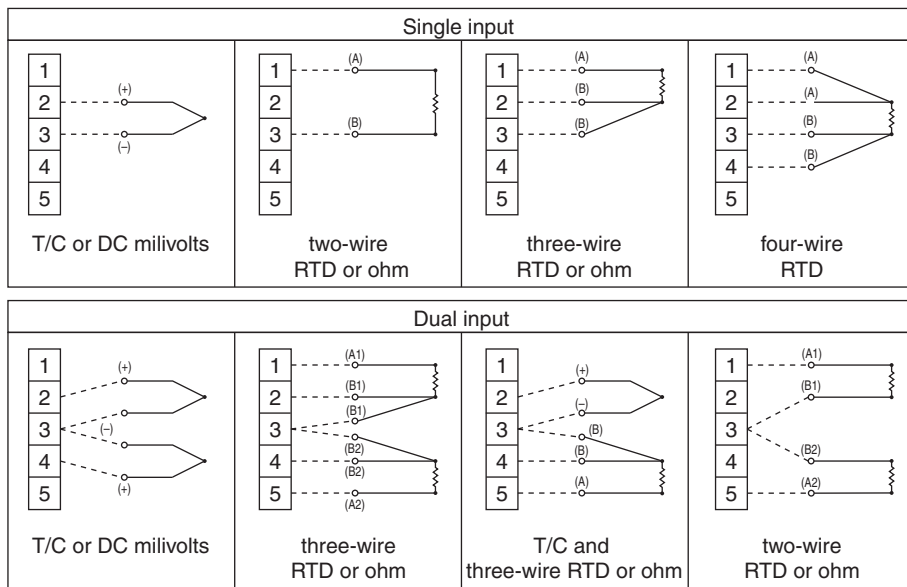

F08.ai

< Ordering Information >

Specify the following when ordering

1. Model, suffix codes, and option codes
2. Sensor type
 - For RTD and resistance input, specify the number of wire as well. (Example; RTD Pt100 3-wire system)
 - When Sensor 2 is not used, select "NON-CONNECTION" for Sensor 2.
 - When "4-WIRE" is selected for Sensor 1, select "NON-CONNECTION" for Sensor 2.
3. Calibration range and unit:
 - Calibration range can be specified within the measurement range shown in Table 1. Also, set the upper limit is larger than the lower limit.
 - When both Sensor 1 and Sensor 2 are used, specify Range 1 and Range 2, respectively.
 - Specify °C or K for Calibration unit except for the following cases:
 - When "mV" or "Ohm" is specified for Sensor type, select "mV" or "Ohm" for Calibration unit respectively.
 - When option code D2 is specified, °F and °R are available.
4. Tag Number (if required)

Specify Tag number (up to 16 letters, valid characters: alphanumeric, hyphen and underscore) to be engraved on the tag plate. The specified letters are written on TAG_Name (16 letters) in the amplifier memory.
5. Software tag (if required)

Engraving on the tag plate can be specified by a combination of uppercase letters, lowercase letters, numbers, "-" (hyphen), "_" (underscore)". Factory setting is blank unless otherwise specified. The tag number specified in "Software tag" will be entered on "TAG_NAME" (up to 16 letters) in the amplifier memory.

6. Network ID (if required)

Specify the number from 2 to 65535. When not specified, it will use 1 as the default.

< Factory Setting >

Table A. Settings upon shipment

Calibration range lower limit	As specified or lower range value for the specified sensor type otherwise specified in order. See Table 1.
Calibration range upper limit	As specified or lower range value for the specified sensor type otherwise specified in order. See Table 1.
Calibration unit	Unit used for specified sensor type
Tag No.	Blank unless otherwise specified in order
Software tag	Blank unless otherwise specified in order
Network ID	'1' unless otherwise specified in order.

<Information on EU WEEE Directive>

EU WEEE (Waste Electrical and Electronic Equipment) Directive is only valid in the EU.

This instrument is intended to be sold and used only as a part of equipment which is excluded from WEEE Directive, such as large-scale stationary industrial tools, a large-scale fixed installation and so on, and, therefore, subjected to the exclusion from the scope of the WEEE Directive. The instrument should be disposed of in accordance with local and national legislation/regulations.