

**Model ZR202S
Integrated type Explosion-proof
Zirconia Oxygen Analyzer**

IM 11M13A01-04E

◆ Introduction

Thank you for purchasing the ZR202S Integrated type Explosion-proof Zirconia Oxygen Analyzer.

Please read the following respective documents before installing and using the ZR202S Integrated type Explosion-proof Zirconia Oxygen Analyzer.

The related documents are as follows.

General Specifications

Contents	Document number	Note
Model ZR22S and ZR202S Explosion-proof Direct In Situ Zirconia Oxygen Analyzer	GS 11M13A01-01E	

* the "E" in the document number is the language code.

User's Manual

Contents	Document number	Note
Model ZR202S Integrated type Explosion-proof Zirconia Oxygen Analyzer	IM 11M13A01-04E	(This manual)
Model ZR22A, ZR202A Heater Assembly	IM 11M12A01-21E	
Model EXAxt ZR Series HART Protocol	IM 11M12A01-51E	

* the "E" or "EN" in the document number is the language code.

An exclusive User's Manual might be attached to the products whose suffix codes or option codes contain the code "Z" (made to customers' specifications). Please read it along with this manual.

The EXAxt ZR Integrated type Explosion-proof Zirconia Oxygen Analyzer has been developed for combustion control in various industrial processes. There are several version of this analyzer so you can select one that matches your application.

Optional accessories are also available to improve measurement accuracy and automate calibration. An optimal control system can be realized by adding appropriate options.

This instruction manual describes almost all of the equipment related to the EXAxt ZR. You may skip any section(s) regarding equipment which is not included in your system.

Regarding the HART Communication Protocol, refer to IM 11M12A01-51E.

IM 11M12A01-51E has been published as "Model EXAxt ZR series HART protocol".

Regarding Separate type Explosion-proof Zirconia Oxygen Analyzer, refer to IM 11M13A01-02E.

Before using the equipment, please read any description in this manual related to the equipment and the system, on appropriate use and operation of the EXAxt ZR.

Models and descriptions in this manual are listed below.

Model	Product Name	Description in this manual				
		Specification	Installation	Operation	Maintenance	CMPL
ZR202S	Integrated type Explosion-proof Zirconia Oxygen Analyzer	○	○	○	○	○
ZO21R-L	Probe Protector	○	○			
ZA8F	Flow Setting Unit (for manual calibration use)	○	○	○		
—	Automatic Calibration Unit	○	○	○		○
—	Calibration Gas Unit Case (Part No. E7044KF)	○	○			
—	Check Valve (Part No. K9292DN, K9292DS)	○	○			
ZO21S	Standard Gas Unit	○		○	○	○

CMPL: Customer Maintenance Parts List

This manual consists of twelve chapters. Please refer to the reference chapters for installation, operation and maintenance.

Table and Contents

Chapter	Outline	Relates to		
		Installation	Operation	Maintenance
1. Overview	Equipment models and system configuration examples	○	△	○
2. Specifications	Standard specification, model code (or part number), dimension drawing for each equipment	◎	○	○
3. Installation	Installation method for each equipment	◎		△
4. Piping	Examples of piping in two standard system configurations	◎		△
5. Wiring	Wiring procedures such as "Power supply wiring", "Output signal wiring" or others	◎		△
6. Components	Major parts and functions are described	△	○	○
7. Startup	Basic procedure to start operation of EXAxt ZR. Chapter 7 enables you to operate the equipment immediately.		◎	△
8. Detailed Data Setting	Details of key operations and displays		○	△
9. Calibration	Describes the calibration procedure required in the course of operation		○	△
10. Other Functions	Other functions described		○	△
11. Inspection and Maintenance	How to conduct maintenance of EXAxt ZR and procedures for replacement of deteriorated parts		○	◎
12. Troubleshooting	This chapter describes measures to be taken when an abnormal condition occurs		△	◎
CMPL (parts list)	User replaceable parts list		△	○

◎ : Read and completely understand before operating the equipment.

○ : Read before operating the equipment, and refer to it whenever necessary.

△ : Recommended to read at least once.

■ Precautions in Handling Explosion-proof Zirconia Oxygen Analyzer

The explosion-proof zirconia oxygen analyzer (Model ZR202S) are designed as explosion-proof instruments.

When using either of these instruments in an explosion-susceptible hazardous area, note the following and observe the given precautions:

Use only the supplied, the explosion-proof zirconia oxygen analyzer (Model ZR202S) and accessories, or any explosion-proof certification may be invalidated.

For the details, refer to the system configurations in the manual.

CAUTION

Only trained persons use this instrument in industrial locations.

Explosion-proof Approval followings:

ZR202S-A (ATEX);	Ex db IIB+H ₂ T2 Gb, Ex tb IIIC T300°C Db
ZR202S-B (FM);	Class I, Division 1, Groups B, C and D, Class II/III, Division 1, Groups E, F and G, T2
ZR202S-C (CSA);	Class I, Division 1, Groups B, C and D, Class II/III, Division 1, Groups E, F and G, T2
ZR202S-D (IECEX);	Ex db IIB+H ₂ T2 Gb, Ex tb IIIC T300°C Db

■ For the safe use of this equipment

WARNING

EXAxt ZR is very heavy. Be sure not to accidentally drop it. Handle safely to avoid injury.

Connect the power supply cord only after confirming that the supply voltage matches the rating of this equipment. In addition, confirm that the power is switched off when connecting power supply.

Some process gas is dangerous to people. When removing this equipment from the process line for maintenance or other reasons, protect yourself from potential poisoning by using a protective mask or ventilating the area well

CAUTION

Requirements for explosion-proof use:

The ambient temperature is in the range of -20 to +55°C. The surface temperature of the ZR202S is not over the temperature class T2 (300°C)*

* The surface temperature of the amplifier box does not exceed 70°C.

Oxygen concentration of sample/reference /calibration gas shall not exceed that found in normal air, typically 21 vol%.

NOTE

The cell (sensor) at the tip of the probe is made of ceramic (zirconia element). Do not drop the equipment or subject it to pressure stress.

- Do NOT allow the sensor (probe tip) to make contact with anything when installing the analyzer.
 - Avoid any water dropping directly on the probe (sensor) of the analyzer when installing it.
 - Check the calibration gas piping before introducing the calibration gas to ensure that there is no leakage of the gas. If there is any leakage of the gas, the moisture drawn from the sample gas may damage the sensor.
 - The probe (especially at the tip) becomes very hot. Be sure to handle it with gloves.
-

(1) About This Manual

- This manual should be passed on to the end user.
- The contents of this manual are subject to change without prior notice.
- The contents of this manual shall not be reproduced or copied, in part or in whole, without permission.
- This manual explains the functions contained in this product, but does not warrant that those will suit the particular purpose of the user.
- Every effort has been made to ensure accuracy in the preparation of this manual. However, should any errors or omissions come to the attention of the user, please contact the nearest Yokogawa Electric representative or sales office.
- This manual does not cover the special specifications. This manual may not be changed on any change of specification, construction and parts when the change does not affect the functions or performance of the product.
- If the product is used in a manner not specified in this manual, the safety of this product may be impaired.

 **CAUTION**

This instrument is tested and certified as explosion-proof type. Please note that the construction of the instrument, installation, external wiring, maintenance or repair is strictly restricted, and non-observation or negligence of this restriction would result in dangerous condition.

● Specification check

When the instrument arrives, unpack the package with care and check that the instrument has not been damaged during transportation. In addition, please check that the specification matches the order, and required accessories are not missing. Specifications can be checked by the model codes on the nameplate. Refer to Chapter 2 Specifications for the list of model codes.

◆ Safety Precautions

■ Safety, Protection, and Modification of the Product

- In order to protect the system controlled by the product and the product itself and ensure safe operation, observe the safety precautions described in this user's manual. We assume no liability for safety if users fail to observe these instructions when operating the product.
- If this instrument is used in a manner not specified in this user's manual, the protection provided by this instrument may be impaired.
- If any protection or safety circuit is required for the system controlled by the product or for the product itself, prepare it separately.
- Be sure to use the spare parts approved by Yokogawa Electric Corporation (hereafter simply referred to as YOKOGAWA) when replacing parts or consumables.
- Modification of the product is strictly prohibited.
- The following safety symbols are used on the product as well as in this manual.



WARNING

This symbol indicates that an operator must follow the instructions laid out in this manual in order to avoid the risks, for the human body, of injury, electric shock, or fatalities. The manual describes what special care the operator must take to avoid such risks.



CAUTION

This symbol indicates that the operator must refer to the instructions in this manual in order to prevent the instrument (hardware) or software from being damaged, or a system failure from occurring.

CAUTION

This symbol gives information essential for understanding the operations and functions.

NOTE

This symbol indicates information that complements the present topic.



Protective Ground Terminal



Function Ground Terminal (Do not use this terminal as the protective ground terminal.)



Alternating current

■ Special descriptions in this manual

This manual indicates operation keys, displays and drawings on the product as follows:

- Operation keys, displays on the panel
 Enclosed in []. (Ex. "MODE" key)
 (Ex. message display → "BASE")
 (Ex. data display → "102" lit, "102" flashing)
- Drawing for flashing
 Indicated by gray characters (Flashing) *102* (lit) *102*
- Displays on the LCD display panel

Alphanumerics	LED Display	Alphanumerics	LED Display	Alphanumerics	LED Display
A	<i>A</i>	N	<i>n</i>	0	<i>0</i>
B	<i>b</i>	O	<i>o</i>	1	<i>1</i>
C	<i>C</i>	P	<i>P</i>	2	<i>2</i>
D	<i>d</i>	Q	<i>q</i>	3	<i>3</i>
E	<i>E</i>	R	<i>r</i>	4	<i>4</i>
F	<i>F</i>	S	<i>S</i>	5	<i>5</i>
G	<i>G</i>	T	<i>t</i>	6	<i>6</i>
H	<i>H</i>	U	<i>U</i>	7	<i>7</i>
I	<i>I</i>	V	<i>V</i>	8	<i>8</i>
J	<i>J</i>	W	<i>W</i>	9	<i>9</i>
K	<i>K</i>	Y	<i>Y</i>		
L	<i>L</i>	Z	<i>Z</i>		
M	<i>M</i>				

■ Warning and Disclaimer

The product is provided on an “as is” basis. YOKOGAWA shall have neither liability nor responsibility to any person or entity with respect to any direct or indirect loss or damage arising from using the product or any defect of the product that YOKOGAWA can not predict in advance.

■ Notes on Handling User’s Manuals

- Please hand over the user’s manuals to your end users so that they can keep the user’s manuals on hand for convenient reference.
- Please read the information thoroughly before using the product.
- The purpose of these user’s manuals is not to warrant that the product is well suited to any particular purpose but rather to describe the functional details of the product.
- No part of the user’s manuals may be transferred or reproduced without prior written consent from YOKOGAWA.
- YOKOGAWA reserves the right to make improvements in the user’s manuals and product at any time, without notice or obligation.
- If you have any questions, or you find mistakes or omissions in the user’s manuals, please contact our sales representative or your local distributor.

■ Drawing Conventions

Some drawings may be partially emphasized, simplified, or omitted, for the convenience of description.

Some screen images depicted in the user’s manual may have different display positions or character types (e.g., the upper / lower case). Also note that some of the images contained in this user’s manual are display examples.

■ Product Disposal:

The instrument should be disposed of in accordance with local and national legislation/regulations.

■ Trademark Acknowledgments

- All other company and product names mentioned in this user’s manual are trademarks or registered trademarks of their respective companies.
- We do not use TM or ® mark to indicate those trademarks or registered trademarks in this user’s manual.

◆ CE marking products

■ Authorized Representative in EEA

The Authorized Representative for this product in EEA is Yokogawa Europe B.V. (Euroweg 2, 3825 HD Amersfoort, The Netherlands).

■ Identification Tag

This manual and the identification tag attached on packing box are essential parts of the product. Keep them together in a safe place for future reference.

■ Users

This product is designed to be used by a person with specialized knowledge.

● How to dispose the batteries:

This is an explanation about the EU Battery Directive. This directive is only valid in the EU. Batteries are included in this product. Batteries incorporated into this product cannot be removed by yourself. Dispose them together with this product.

Battery type: Manganese dioxide lithium battery



Notice:

The symbol (see above) means they shall be sorted out and collected as ordained in the EU Battery Directive.

■ Information of the WEEE Directive

This product is purposely designed to be used in a large scale fixed installations only and, therefore, is out of scope of the WEEE Directive. The WEEE Directive does not apply. This product should be disposed in accordance with local and national legislation/regulations. The WEEE Directive is only valid in the EU.



After-Sales Warranty

- Do not modify the product.
- Yokogawa warrants the product for the period stated in the pre-purchase quotation. Yokogawa shall conduct defined warranty service based on its standard.
- During the warranty period, for repair under warranty carry or send the product to the local sales representative or service office. Yokogawa will replace or repair any damaged parts and return the product to you.
 - Before returning a product for repair under warranty, provide us with the model name and serial number and a description of the problem. Any diagrams or data explaining the problem would also be appreciated.
 - If we replace the product with a new one, we won't provide you with a repair report.
- **In the following cases, customer will be charged repair fee regardless of warranty period.**
 - Failure of components which are out of scope of warranty stated in instruction manual.
 - Failure caused by usage of software, hardware or auxiliary equipment, which Yokogawa did not supply.
 - Failure due to improper or insufficient maintenance by user.
 - Failure due to modification, misuse or outside-of-specifications operation which Yokogawa does not authorize.
 - Failure due to power supply (voltage, frequency) being outside specifications or abnormal.
 - Failure caused by any usage out of scope of recommended usage.
 - Any damage from fire, earthquake, storms and floods, lightning, disturbances, riots, warfare, radiation and other natural changes.
- **Yokogawa does not warrant conformance with the specific application at the user site. Yokogawa will not bear direct/indirect responsibility for damage due to a specific application.**
- **Yokogawa will not bear responsibility when the user configures the product into systems or resells the product.**
- **Maintenance service and supplying repair parts will be covered for five years after the production ends. For repair for this product, please contact the nearest sales office described in this instruction manual.**

Model ZR202S

Integrated type Explosion-proof Zirconia Oxygen Analyzer

IM 11M13A01-04E 13th Edition

CONTENTS

◆	Introduction.....	i
◆	Safety Precautions	v
◆	CE marking products	viii
◆	After-Sales Warranty	ix
1.	Overview.....	1-1
1.1	< EXAxt ZR > System Configuration.....	1-1
1.1.1	System 1	1-1
1.1.2	System 2	1-2
1.2	< EXAxt ZR > System Components	1-2
1.2.1	System Components	1-2
1.2.2	Oxygen Analyzer and Installation	1-2
2.	Specifications	2-1
2.1	General Specifications	2-1
2.1.1	Standard Specifications	2-1
2.1.2	ZR202S Integrated type Explosion-proof Zirconia Oxygen Analyzer	2-4
2.1.3	ZO21R Probe Protector	2-12
2.2	ZA8F Flow Setting Unit.....	2-13
2.3	ZO21S Standard Gas Unit	2-15
2.4	Other Equipment.....	2-16
2.4.1	Stop Valve (L9852CB, G7016XH)	2-16
2.4.2	Check Valve (K9292DN, K9292DS)	2-16
2.4.3	Air Set.....	2-17
2.4.4	Pressure Reducing Valve for Gas Cylinder (G7013XF, G7014XF)	2-18
2.4.5	ZR202A Heater Assembly	2-19
3.	Installation.....	3-1
3.1	Installation of ZR202S Zirconia Oxygen Analyzer.....	3-1
3.1.1	Installation Location	3-1
3.1.2	ATEX Flameproof Type.....	3-2
3.1.3	FM Explosion-proof Type	3-3
3.1.4	CSA Explosion-proof Type.....	3-4
3.1.5	IECEX Flameproof Type.....	3-5
3.1.6	Probe (Detector) Insertion Hole	3-7
3.1.7	Installation of the Probe (Detector)	3-7
3.1.8	Installation of the Probe Protector (ZO21R)	3-8

3.2	Installation of ZA8F Flow Setting Unit	3-8
3.2.1	Installation Location	3-8
3.2.2	Mounting of ZA8F Flow Setting Unit.....	3-9
3.3	Insulation Resistance Test	3-10
4.	Piping	4-1
4.1	Piping for System 1	4-2
4.1.1	Piping Parts for System 1	4-2
4.1.2	Piping for the Calibration Gas Inlet	4-3
4.1.3	Piping for the Reference Gas Inlet.....	4-3
4.1.4	Piping for the Reference Gas Outlet.....	4-3
4.2	Piping for System 2	4-4
5.	Wiring	5-1
5.1	General	5-1
5.1.1	Terminals for the External Wiring.....	5-2
5.1.2	Wiring	5-2
5.1.3	Mounting of Cable Gland	5-3
5.2	Wiring for Analog Output	5-3
5.2.1	Cable Specifications	5-3
5.2.2	Wiring Procedure	5-3
5.3	Wiring Power and Ground Terminals	5-4
5.3.1	Wiring for Power Line.....	5-4
5.3.2	Wiring for Ground Terminals	5-4
5.4	Wiring for Contact Output	5-5
5.4.1	Cable Specifications	5-5
5.4.2	Wiring Procedure	5-5
5.5	Wiring for Contact Input	5-5
5.5.1	Cable Specifications	5-5
5.5.2	Wiring Procedure	5-5
6.	Components	6-1
6.1	ZR202S Zirconia Oxygen Analyzer	6-1
6.2	ZA8F Flow Setting Unit, Automatic Calibration Unit	6-2
7.	Startup	7-1
7.1	Checking Piping and Wiring Connections	7-2
7.2	Valve Setup	7-2
7.3	Supplying Power to Analyzer	7-2
7.4	Operation of Infrared Switch	7-3
7.4.1	Display and Switches.....	7-3
7.4.2	Display Configuration.....	7-4
7.4.3	Entering Parameter Code Selection Display	7-5
7.4.4	Selecting Parameter Codes.....	7-6
7.4.5	Changing Set Values	7-7
7.5	Confirmation of Equipment Type Setting	7-8

7.6	Selection of Measurement Gas	7-9
7.7	Output Range Setting	7-9
7.8	Checking Current Loop	7-11
7.9	Checking Contact I/O	7-11
7.9.1	Checking Contact Output.....	7-12
7.9.2	Checking Calibration Contact Output	7-13
7.9.3	Checking Contact Input	7-14
7.10	Calibration	7-15
7.10.1	Calibration Setup	7-15
7.10.2	Manual Calibration	7-17
8.	Detailed Data Setting	8-1
8.1	Setting Display Item	8-1
8.2	Current Output Setting	8-1
8.2.1	Setting Minimum Oxygen Concentration (at 4 mA) and Maximum Oxygen Concentration (at 20 mA)	8-2
8.2.2	Entering Output Damping Constants.....	8-2
8.2.3	Selection of Output Mode	8-2
8.2.4	Default Values	8-2
8.3	Output Hold Setting	8-3
8.3.1	Definition of Equipment Status	8-3
8.3.2	Preference Order of Output Hold Value.....	8-5
8.3.3	Output Hold Setting.....	8-5
8.3.4	Default Values	8-5
8.4	Oxygen Concentration Alarms Setting	8-6
8.4.1	Setting the Alarm Values	8-6
8.4.2	Alarm Output Actions	8-6
8.4.3	Alarm Setting.....	8-7
8.4.4	Default Values	8-8
8.5	Contact Output Setting	8-8
8.5.1	Contact Output.....	8-8
8.5.2	Setting Contact Output.....	8-9
8.5.3	Default Values	8-10
8.6	Contact Input Setting	8-11
8.6.1	Setting Contact Input	8-11
8.6.2	Default Values	8-11
8.7	Other Settings	8-12
8.7.1	Setting the Date-and-Time.....	8-12
8.7.2	Setting Periods over which Average Values are Calculated and Periods over which Maximum and Minimum Values Are Monitored ...	8-13
8.7.3	Setting Fuels	8-14
8.7.4	Setting Purging	8-18

9.	Calibration	9-1
9.1	Calibration Briefs	9-1
9.1.1	Principle of Measurement	9-1
9.1.2	Calibration Gas	9-2
9.1.3	Compensation	9-3
9.1.4	Characteristic Data from a Sensor Measured During Calibration	9-4
9.2	Calibration Procedures	9-5
9.2.1	Calibration Setting	9-5
9.2.2	Calibration	9-8
10.	Other Functions	10-1
10.1	Detailed Display	10-1
10.1.1	Air Ratio.....	10-3
10.1.2	Cell Temperature.....	10-3
10.1.3	C. J. Temperature.....	10-3
10.1.4	Amount of Water Vapor in Exhaust Gas	10-3
10.1.5	Cell Voltage	10-4
10.1.6	Thermocouple Voltage.....	10-4
10.1.7	Cold Junction Voltage	10-4
10.1.8	Current Output	10-4
10.1.9	Response Time	10-5
10.1.10	Cell's Internal Resistance	10-5
10.1.11	Robustness of a Cell.....	10-5
10.1.12	Heater On-Time Ratio.....	10-6
10.1.13	Oxygen Concentration (with time constant)	10-6
10.1.14	Maximum Oxygen Concentration	10-6
10.1.15	Minimum Oxygen Concentration	10-6
10.1.16	Average Oxygen Concentration	10-6
10.1.17	Span and Zero Correction Ratios	10-6
10.1.18	History of Calibration Time.....	10-7
10.1.19	Time	10-7
10.1.20	Software Revision	10-7
10.2	Operational Data Initialization	10-8
10.3	Initialization Procedure	10-9
10.4	Reset	10-10
10.5	Handling of the ZO21S Standard Gas Unit	10-17
10.5.1	Standard Gas Unit Component Identification	10-17
10.5.2	Installing Gas Cylinders	10-18
10.5.3	Calibration Gas Flow.....	10-18
10.6	Methods of Operating Valves in the ZA8F Flow Setting Unit	10-20
10.6.1	Preparation Before Calibration	10-20
10.6.2	Operating the Span Gas Flow Setting Valve	10-20
10.6.3	Operating the Zero Gas Flow Setting Valve	10-20
10.6.4	Treatment After Calibration	10-20

11.	Inspection and Maintenance	11-1
11.1	Inspection and Maintenance of the Detector	11-2
11.1.1	Cleaning the Calibration Gas Tube	11-2
11.1.2	Replacing the Sensor Assembly	11-2
11.1.3	Replacement of the Heater Assembly	11-4
11.1.4	Replacement of Flame Arrestor Assembly	11-6
11.1.5	Replacement of O-ring	11-7
11.1.6	Stopping and Re-starting Operation	11-7
11.2	Inspection and Maintenance of the Analyzer	11-8
11.3	Replacement of Flowmeter for Automatic Calibration Unit	11-10
12.	Troubleshooting	12-1
12.1	Displays and Remedies When Errors Occur	12-1
12.1.1	Error Types	12-1
12.1.2	Remedies When an Error Occurs	12-2
12.2	Displays and Remedies When Alarms are Generated	12-4
12.2.1	Alarm types	12-4
12.2.2	Remedies When Alarms are Generated	12-5
12.3	Measures When Measured Value Shows an Error	12-9
12.3.1	Measured Value Higher Than True Value	12-9
12.3.2	Measured Value Lower Than True Value	12-10
12.3.3	Measurements Sometimes Show Abnormal Values	12-10
	Customer Maintenance Parts List	CMPL 11M13A01-04E
	Customer Maintenance Parts List	CMPL 11M3D1-01E
	Revision Information	i

1. Overview

The EXAxt ZR Integrated type Explosion-proof Zirconia Oxygen Analyzer is used to monitor and control the oxygen concentration in combustion gases, in boilers and industrial furnaces, for wide application in industries which consume considerable energy—such as steel, electric power, oil and petrochemical, ceramics, pulp and paper, food, or textiles, as well as incinerators and medium/small boilers. It can help conserve energy in these industries. The EXAxt ZR also contributes to preservation of the earth’s environment in preventing global warming and air pollution by controlling complete combustion to reduce CO₂, SO_x and NO_x.

The EXAxt ZR Integrated type Explosion-proof Zirconia Oxygen Analyzer integrates both probe and converter. The analyzers need not use a sampling device, and allow direct installation of the probe in the wall of a flue or furnace to measure the concentration of oxygen in the stack gas of the temperature up to 700°C.

The probe uses a high-reliability Zirconia sensor and a heater assembly that can be replaced on site.

The analyzer is equipped with three infrared switches, which enable the user to operate the equipment without opening the cover on site. Analyzer calibration can also be fully automated and the automatic calibration unit is provided. Choose the equipment which best suits your needs so that an optimal combustion control system can be obtained.

Some examples of typical system configuration are illustrated below:

1.1 < EXAxt ZR > System Configuration

The system configuration should be determined by the conditions; e.g. whether the calibration is to be automated, and whether flammable gas is present and requires safety precautions. The system configuration can be classified into two basic patterns as follows:

1.1.1 System 1

This system is for monitoring and controlling oxygen concentration in the combustion gases of a large-size boiler or heating furnace. Instrument air (clean and dry air of oxygen concentration 21%) is used as the reference gas and the span gas for calibration. Zero gas is fed from a cylinder during calibration. The gas flow is controlled by the ZA8F flow setting unit (for manual valve operation).

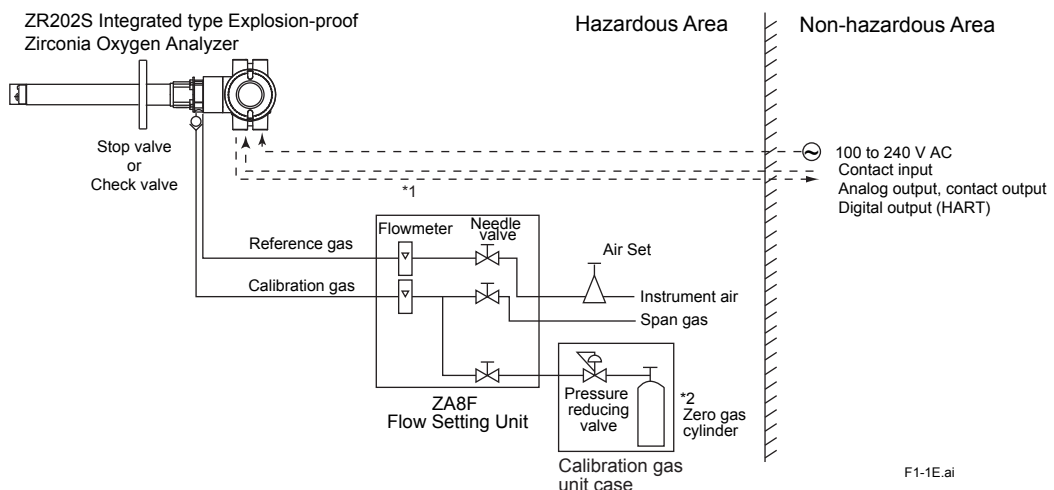

Figure 1.1 Example of System 1

- Note:
The installation temperature limits range for integrated type analyzer is -20 to 55°C.
- *1 Shield cable:
Use shielded signal cables, and connect the shields to the FG terminal of the analyzer.
 - *2 When a zirconia oxygen analyzer is used, 100%N₂ gas cannot be used as the zero gas.
Use approx. 1 vol%O₂ gas (N₂-based).

1.1.2 System 2

This example, System 2, represents typical applications in large boilers and heating furnaces, where there is a need to monitor and control oxygen concentration. Instrument air (clean, dry) is used as the reference gas and span gas for calibration. Zero gas is supplied from a gas cylinder.

System 2 uses the automatic calibration unit, with auto-switching of the calibration gas. A “combustible gas detected” contact input turns off power to the heater. There’s also contact output from the analyzer that can be used to operate a purge gas valve to supply air to the sensor.

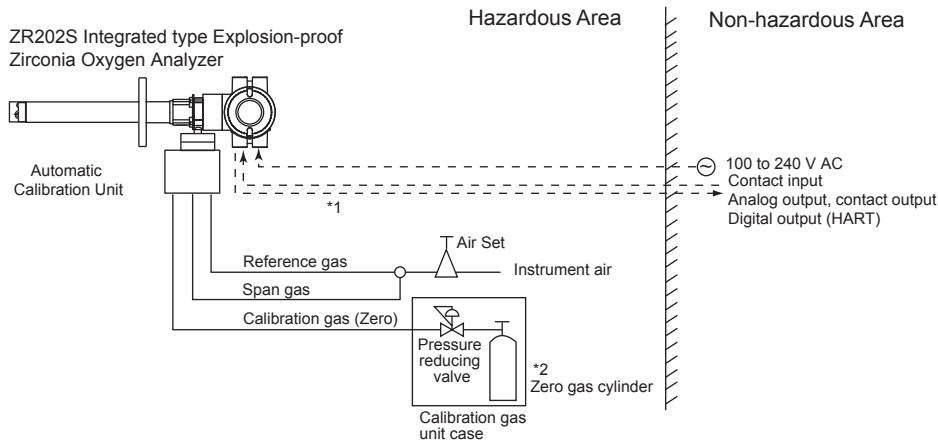

Figure 1.2 Example of System 2

1.2 < EXAxt ZR > System Components

1.2.1 System Components

System Components	Integrated type	
	System configuration	
	Example 1	Example 2
ZR202S Integrated type Zirconia Oxygen Analyzers	●	●
ZO21R Probe Protector for Zirconia Oxygen Analyzers	●	
ZO21S Standard Gas Unit	○	○
Automatic Calibration Unit for integrated type Analyzer	●	●
L9852CB, G7016XH Stop Valve for Calibration gas line	(●)	
K9292DN, K9292DS Check Valve for Calibration gas line	(●)	●
G7003XF/K9473XK, G7004XF/K9473XG Air Set	●	●
G7013XF, G7014XF Pressure Reducing Valve for Gas Cylinder	●	●
ZR202A Heater Assembly (Spare Parts for ZR202S)	○	○

● : Items required for the above system example

○ : To be selected depending on each application. For details, refer to corresponding chapter.

(●): Select either

T1-1.ai

1.2.2 Oxygen Analyzer and Installation

Sample gas temperature 0 to 700°C			
Mounting	Insertion length	General-use Probe	Application
Horizontal to vertical	0.4 to 2 m	<p>Integrated type Analyzer (ZR202S)</p>	Boiler, Heating furnace

2. Specifications

This chapter describes the specifications for the following:

ZR202S	Integrated type Explosion-proof Zirconia Oxygen Analyzer	(See Subsection 2.1.2)
ZO21R-L	Probe Protector	(See Subsection 2.1.3)
ZA8F	Flow Setting Unit	(See Subsection 2.2.1)
	Automatic Calibration Unit	(See Subsection 2.2.2)
ZO21S	Standard Gas Unit	(See Section 2.3)
	Other equipments	(See Section 2.4)



CAUTION

Requirements for explosion-proof use:

The ambient temperature is in the range of -20 to +55°C. The surface temperature of the ZR202S is not over the temperature class T2 (300°C)(*)

(*) The surface temperature of the amplifier box does not exceed 70°C.

Oxygen concentration of sample/reference/calibration gas shall not exceed that found in normal air, typically 21 vol%.

2.1 General Specifications

2.1.1 Standard Specifications

Measured Object:	Oxygen concentration in combustion exhaust gas and mixed gas (excluding inflammable gases. May not be applicable corrosive gas such as ammonia and chlorine is present - Contact with YOKOGAWA and its agency).
Measurement System:	Zirconia system
Measurement Range:	0.01 to 100 vol%O ₂
Output Signal:	4 to 20 mA DC (maximum load resistance 550 Ω)
Setting Range:	Any setting in the range of 0 to 5 through 0 to 100 vol%O ₂ (in 1 vol%O ₂), or partial range
Digital Communication (HART):	250 to 550 Ω, depending on number of field devices connected to the loop (multi-drop mode).

Note: HART is a registered trademark of the HART Communication Foundation.

Display Range:	0 to 100 vol%O ₂
Warm-up Time:	Approx. 20 min.

● Explosion-proof Approval:

ATEX Flameproof: ZR202S-A;

Applicable Standard: EN IEC 60079-0: 2018, EN 60079-1: 2014, EN 60079-31: 2014

Certificate Number: KEMA 04ATEX2156 X

Type of protection: Ex db IIB+H₂ T2 Gb, Ex tb IIIC T300°C Db

Equipment Group: II
 Category: 2GD
 Temperature class for Ex "db": T2

The maximum surface temperature for Ex "tb": T300°C

Degree of protection of enclosure: IP66

NAME PLATE

INTEGRAL TYPE ZIRCONIA ANALYZER		 WARNING DO NOT OPEN WHEN AN EXPLOSIVE GAS ATMOSPHERE IS PRESENT · POTENTIAL ELECTROSTATIC CHARGING HAZARD - READ USER'S MANUAL (IM 11M13A01-04) · FOR INSTALLATION AND SAFE USE, READ IM 11M13A01-04
MODEL	ZR202S	
SUFFIX		 HIGH TEMPERATURE · USE AT LEAST 80°C HEAT RESISTANT CABLES & CABLE GLANDS
STYLE		
SUPPLY	100-240V AC~ 50/60Hz MAX.300W	 0344  II2G <input type="checkbox"/> Ex db IIB+H ₂ T2 Gb  II2D <input type="checkbox"/> Ex tb IIIC T300°C Db No. KEMA 04ATEX2156 X ENCLOSURE : IP66
AMB.TEMP	-20 TO 55°C	
NO.		 YOKOGAWA ◆ Made in Japan Yokogawa Electric Corporation Tokyo 180-8750 JAPAN

MODEL : Specified model code

SUFFIX : Specified suffix code

STYLE : Style code

AMB. TEMP : Ambient temperature

NO. : Serial No. and year of production*1

Yokogawa Electric Corporation : The manufacturer name

Tokyo 180-8750 JAPAN : The manufacturer address*2

The country of origin

Note: "□" is the checkbox for selecting type of protection.

Apply a permanent mark in the checkbox of selected the type of protection.

Once the type of protection is selected, it shall not be changed.

*1: The third to seventh figure from the last shows the year of production.
 e.g. 27D327560 2005.02

↑ The year of production

*2: "180-8750" is a zip code which represents the following address.
 2-9-32 Nakacho, Musashino-shi, Tokyo Japan

FM Explosion-proof: ZR202S-B

Applicable Standard: FM3600 2011, FM3615 2006, FM3810 2005, ANSI/NEMA 250 1991

Type of protection: Explosion-proof for Class I, Division 1, Groups B, C and D

Dust-ignitionproof for Class II/III, Division 1, Groups E, F and G

Enclosure Rating: NEMA 4X

Temperature Class: T2

CSA Explosion-proof: ZR202S-C

Applicable Standard: C22.2 No.0-M1991, C22.2 No.0.4-04, C22.2 No.0.5-1982,
 C22.2 No.25-1966, C22.2 No.30-M1986, C22.2 No.94-M91,
 C22.2-No.61010-1-04

Certificate Number: 1649642

Type of protection: Explosion-proof for Class I, Division 1, Groups B, C and D

Dust-ignitionproof for Class II/III, Division 1, Groups E, F and G

Enclosure: Type 4X

Temperature Class: T2

IECEx Flameproof: ZR202S-D

Applicable Standard: IEC 60079-0: 2017, IEC 60079-1: 2014, IEC 60079-31: 2013

Certificate Number: IECEx KEM 06.0006X







Type of protection: Ex db IIB+H₂ T2 Gb, Ex tb IIIC T300°C Db

Temperature class for Ex "db": T2

The maximum surface temperature for Ex "tb": T300°C

Degree of protection of enclosure: IP66

NAME PLATE

INTEGRAL TYPE ZIRCONIA ANALYZER		 WARNING ·DO NOT OPEN WHEN AN EXPLOSIVE GAS ATMOSPHERE IS PRESENT ·POTENTIAL ELECTROSTATIC CHARGING HAZARD ·READ USER'S MANUAL (IM 11M13A01-04) ·FOR INSTALLATION AND SAFE USE, READ IM 11M13A01-04
MODEL	ZR202S	
SUFFIX		 HIGH TEMPERATURE ·USE AT LEAST 80°C HEAT RESISTANT CABLES & CABLE GLANDS
STYLE		
SUPPLY	100-240V AC~ 50/60Hz MAX. 300W	   
AMB. TEMP	-20 TO 55°C	
NO.		
No. IECEx	KEM 06.0006X	
<input type="checkbox"/>	Ex db IIB+H ₂ T2 Gb	
<input type="checkbox"/>	Ex tb IIIC T300°C Db	
ENCLOSURE : IP66		
YOKOGAWA ◆ Made in Japan		Yokogawa Electric Corporation Tokyo 180-8750 JAPAN

MODEL : Specified model code
 SUFFIX : Specified suffix code
 STYLE : Style code
 AMB. TEMP : Ambient temperature
 NO. : Serial No. and year of production*1
 Yokogawa Electric Corporation : The manufacturer name
 Tokyo 180-8750 JAPAN : The manufacturer address*2

The country of origin

Note: "☐" is the checkbox for selecting type of protection.
 Apply a permanent mark in the checkbox of selected the type of protection.
 Once the type of protection is selected, it shall not be changed.

*1: The third to seventh figure from the last shows the year of production.
 e.g. 27D327560 2005.02
 ↑ The year of production

*2: "180-8750" is a zip code which represents the following address.
 2-9-32 Nakacho, Musashino-shi, Tokyo Japan

EAC Flameproof : ZR220S-Q / ZR202S-R

Applicable Standard: TP TC 012/2011
 Certificate Number: RU C-JP.AA87.B.00040/18
 Type of Protection: 1Ex db IIB+H₂ T2 Gb X, Ex tb IIIC T300°C Db X
 Temperature class for Ex "db": T2
 The maximum surface temperature for Ex "tb": T300°C
 Degree of Protection of Enclosure: IP66

KOSHA Explosion-proof: ZR202S-K

Applicable Standard: Notice of Ministry of Labor No. 2016-54
 Certificate Number: 18-AV4BO-0060X
 Type of protection: Ex d IIB+H₂ T2
 Temperature class for Ex "d": T2
 Degree of protection of enclosure: IP66

Safety, EMC, and RoHS conformity standards

Installation altitude based on IEC 61010-1: 2000 m or less

Category based on IEC 61010-1: II (Note)

Pollution degree based on IEC 61010-1: 2 (Note)

Note: Installation category, called over-voltage category, specifies impulse withstand voltage.
 Category II is for electrical equipment. Pollution degree indicates the degree of existence of solid, liquid, gas or other inclusions which may reduce dielectric strength. Degree 2 is the normal indoor environment.

Safety: Conforms to EN 61010-1, EN 61010-2-030, CAN/CSA-C22.2 No. 61010-1 certified,
 UL Std. No. 61010-1 certified

EMC: Conforms to EN 61326-1*, Class A, Table 2,
 EN 61326-2-3, EN 61000-3-2

*: Influence of immunity environment (Criteria A): ±20% of F. S.

EMC Regulatory Arrangement in Australia and New Zealand (RCM) EN61326-1 Class A

Korea Electromagnetic Conformity Standard

Note: This instrument is a Class A product, and it is designed for use in the industrial environment. Please use this instrument in the industrial environment only.

RoHS: EN IEC 63000

Information of the WEEE Directive

This product is purposely designed to be used in a large scale fixed installations only and, therefore, is out of scope of the WEEE Directive. The WEEE Directive does not apply.

The WEEE Directive is only valid in the EU.

Repeatability:	± 0.5% Maximum value of set range; Range from 0 to 5 vol%O ₂ or more and less than 0 to 25 vol%O ₂ range ± 1 % Maximum value of set range; Range from 0 to 25 vol%O ₂ or more and up to 0 to 100 vol%O ₂ .
Linearity:	(Excluding standard gas tolerance) (Use oxygen of known concentration (with in the measuring range) as the zero and span calibration gases.) ± 1% Maximum value of set range; Range from 0 to 5 vol%O ₂ to 0 to 25 vol%O ₂ . (Sample gas pressure: within ± 4.9 kPa) ± 3% Maximum value of set range; Range from 0 to 25 vol%O ₂ or more and less than 0 to 50 vol%O ₂ . (Sample gas pressure: within ± 0.49 kPa) ± 5% Maximum value of set range; Range from 0 to 50 vol%O ₂ to 0 to 100 vol%O ₂ . (Sample gas pressure: within ± 0.49 kPa)
Drift:	(Excluding the first two weeks in use) Both zero and span ± 2% Maximum value of range set/month
Response Time:	Response of 90% within 5 seconds. (Measured after gas is introduced from calibration gas inlet and analog output starts changing.)

2.1.2 ZR202S Integrated type Explosion-proof Zirconia Oxygen Analyzer

Can be operated in the field without opening the cover using optical switches.

Display: 6-digit LCD

Switch: Three optical switches

Output Signal: 4 to 20 mA DC, one point (maximum load resistance 550 Ω)

Digital Communication (HART): 250 to 550 Ω, depending on quantity of field devices connected to the loop (multi-drop mode).

Note: HART is a registered trademark of the HART Communication Foundation.

Contact Output Signal: Two points (one is fail-safe, normally open)

Contact Input Signal: Two points

Sample Gas Temperature: 0 to 700°C

It is necessary to mount the cell using Inconel cell-bolts when the temperature measures more than 600°C.

High-temperature service — greater than 700°C — is not available.

A flame arrester may corrode if sample gas contains the following corrosive gases under 380°C or over.

Greater than 5000 ppm SO₂

Greater than 1000 ppm NO

Greater than 50 ppm HCl

Sample Gas Pressure: -5 to +5 kPa

No pressure fluctuation in the furnace should be allowed.

Oxygen concentration of sample gas:

For explosion-proof use, not more than that found in normal air, typically 21 vol%

Probe Length: 0.4, 0.7, 1.0, 1.5, 2.0 m

Probe Material: 316 SS (JIS)

Ambient Temperature:	-20 to +55°C (case surface temperature is less than +70°C)
Storage Temperature:	-30 to +70°C
Ambient Humidity:	0 to 95%RH (non-condensing)
Power Supply Voltage:	Ratings; 100 to 240 V AC, Acceptable range; 85 to 264 V AC
Power Supply Frequency:	Ratings; 50/60 Hz, Acceptable range; 45 to 66 Hz
Power Consumption:	Max. 300 W, approx. 100 W for ordinary use.
Reference Gas System:	Instrument Air
Instrument Air System:	
Pressure;	50 kPa + the pressure inside the furnace 150 kPa + the pressure inside the furnace with automatic calibration unit or check valve. (It is recommended to use air which has been dehumidified by cooling to dew point -20°C or less, and dust or oil mist are removed.)
Consumption;	Approx. 1.5 NI/min
Oxygen concentration of calibration gas:	For explosion-proof use, not more than that found in normal air, typically 21 vol%
Wetted Material:	316 SS (JIS), Zirconia, 304 SS (JIS) or ASTM grade 304 (flange), Hastelloy B, (Inconel 600, 601)
Construction:	Heater and thermocouple replaceable construction. Equivalent to NEMA 4X/IP66 (Achieved when pipes are installed at calibration gas and reference gas inlets and exhaust pipe is installed so that reference gas can be exhausted to clean atmosphere. Excluding probe top.) (Achieved when the cable entry is completely sealed with a cable gland.)
Gas Connection:	Rc 1/4 or 1/4 NPT(F)
Wiring Connection:	ATEX: M20 by 1.5 mm, 1/2 NPT select one type (4 pieces) FM: 1/2 NPT (4 pieces) CSA: 1/2 NPT (4 pieces) IECEx: M20 by 1.5 mm, 1/2 NPT select one type (4 pieces)
Installation:	Flange mounting
Probe Mounting Angle:	Horizontal to vertically downward.
Case:	Aluminum alloy
Finish:	Polyurethane corrosion-resistance coating
Weight:	Insertion length of 0.4m: approx. 15 kg (ANSI 150 4) Insertion length of 1.0m: approx. 17 kg (ANSI 150 4) Insertion length of 1.5m: approx. 19 kg (ANSI 150 4) Insertion length of 2.0m: approx. 21 kg (ANSI 150 4)

- **Functions:**

- Display Function: Displays values of the measured oxygen concentration, etc.
- Alarm, Error Display: Displays alarms such as “AL-06” or errors such as “Err-01” when any such status occurs.
- Calibration Functions:
- Automatic Calibration; Requires the Automatic Calibration Unit. It calibrates automatically at specified intervals.
 - Semi-automatic Calibration; Requires the Automatic Calibration Unit. Input calibration start signal by optical switch or contact, then it calibrates automatically afterwards.
 - Manual Calibration; Calibration with opening/closing the valve of calibration gas in operation interactively with the optical switch.
- Maintenance Functions: Can operate updated data settings in daily operation and checking.
Display data settings, calibration data settings, test settings (current output loop check, contact input/output check).
- Setup Functions: Initial settings suit for the plant conditions when installing the analyzer.
Current output data settings, alarm data settings, contact data settings, other settings.

- **Display and setting content:**

- Display Related Items: Oxygen concentration (vol%O₂), current output value (mA), air ratio, moisture quantify (in hot gases) (vol%H₂O), cell temperature (°C), thermocouple reference junction temperature (°C), maximum/minimum/average oxygen concentration (vol%O₂), cell e.m.f. (mV), cell internal resistance (Ω), cell condition (in four grades), heater on-time rate (%), calibration record (ten times), time (year/month/day/hour/minute)
- Calibration Setting Items: Span gas concentration (vol%O₂), zero gas concentration (vol%O₂), calibration mode (automatic, semi-automatic, manual), calibration type and method (zero-span calibration, zero calibration only, span calibration only), stabilization time (min.sec), calibration time (min.sec), calibration period (day/hour), starting time (year/month/day/hour/minute)
- Output Related Items: Analog output/output mode selection, output conditions when warming-up/maintenance/calibrating/abnormal, 4 mA/20 mA point oxygen concentration (vol% O₂), time constant.
- Alarm Related Items: Oxygen concentration high alarm/high-high alarm limit values (vol%O₂), Oxygen concentration low alarm/low-low alarm limit values (vol%O₂), Oxygen concentration alarm hysteresis (vol%O₂), Oxygen concentration alarm detection, alarm delay (seconds)
- Contact Related Items: Selection of contact input 1 and 2, selection of contact output 1 and 2 (abnormal, high-high alarm, high alarm, low alarm, low-low alarm, maintenance, calibrating, range switching, warming-up, calibration gas pressure decrease, flameout gas detection (answer-back of contact input)
- Converter Output: One mA analog output (4 to 20 mA DC (maximum load resistance of 550 Ω)) with mA digital output (HART) (minimum load resistance of 250 Ω).
- Range; Any setting between 0 to 5 through 0 to 100 vol%O₂ in 1 vol%O₂, or partial range is available (Maximum range value/minimum range value 1.3 or more)
For the log output, the minimum range value is fixed at 0.1 vol%O₂.
4 to 20 mA DC linear or log can be selected. Input/output isolation.
- Output damping: 0 to 255 seconds. Hold/non-hold selection, preset value setting possible with hold.

- Contact Output:** Two points, contact capacity 30 V DC 3 A, 250 V AC 3 A (resistive load)
One of the output points can be selected to either normally energized or normally de-energized status.
Delayed functions (0 to 255 seconds) and hysteresis function (0 to 9.9 vol%O₂) can be added to high/low alarms.
The following functions are programmable for contact outputs.
(1) Abnormal, (2) High-high alarm, (3) High alarm, (4) Low-low alarm, (5) Low alarm,
(6) Maintenance, (7) Calibration, (8) Range switching answer-back, (9) Warm-up, (10) Calibration gas pressure decrease (answer-back of contact input), (11) Flameout gas detection (answer-back of contact input).
Contact output 2 is set to normally operated, fixed error status.
- Contact Input:** Two points, voltage-free contacts
The following functions are programmable for contact inputs.
(1) Calibration gas pressure decrease alarm, (2) Range switching (switched range is fixed), (3) External calibration start, (4) Process alarm (if this signal is received, the heater power turns off)
- Self-diagnosis:** Abnormal cell, abnormal cell temperature (low/high), abnormal calibration, A/D converter abnormal, digital circuit abnormal
- Calibration:** Method; zero/span calibration
Calibration mode; Automatic, semi-automatic and manual (All are operated using optical switches).
Either zero or span can be skipped.
Zero calibration gas concentration setting range;
0.3 to 100 vol%O₂ (in 0.01 vol%O₂).
Span calibration gas concentration setting range;
4.5 to 100 vol%O₂ (in 0.01 vol%O₂).
Use nitrogen-balanced mixed gas containing 0 to 10 vol%O₂ scale of oxygen for standard zero gas and 80 to 100 vol%O₂ scale of oxygen for standard span gas.
Calibration period; Date/time setting: maximum 255 days/23 hours

● Model and Codes

Model	Suffix code	Option code	Description
ZR202S	-----	-----	Integrated type Explosion-proof Zirconia Oxygen Analyzer
Explosion-proof Approval (*13)	-A -B -C -D -Q -R -K	----- ----- ----- ----- ----- ----- -----	ATEX certified flameproof (*11) FM certified explosion-proof CSA certified explosion-proof IECEX certified flameproof (*11)(*15) EAC with PA certified explosion-proof (*14) EAC certified explosion-proof (*14) KOSHA certified explosion-proof
Length	-040 -070 -100 -150 -200	----- ----- ----- ----- -----	0.4 m 0.7 m 1.0 m 1.5 m 2.0 m
Wetted material	-S -C	----- -----	SUS316 Stainless steel with Inconel calibration gas tube (*7)
Flange (*1)	-A -B -C -E -F -G -K -L -M -P -R -S -W	----- ----- ----- ----- ----- ----- ----- ----- ----- ----- ----- ----- ----- -----	ANSI Class 150 2 RF (*10) ANSI Class 150 3 RF ANSI Class 150 4 RF DIN PN10 DN50 A (*10) DIN PN10 DN80 A DIN PN10 DN100 A JIS 5K 65 FF JIS 10K 65 FF JIS 10K 80 FF JIS 10K 100 FF JPI Class 150 4 RF JPI Class 150 3 RF Westinghouse
Automatic Calibration	-N -A -B	----- ----- -----	Not required Horizontal mounting (*5) Vertical mounting (*5)
Reference gas	-E	-----	External connection (Instrument air) (*8)
Gas Thread	-R -T	----- -----	Rc 1/4 1/4 NPT (Female)
Connection box thread	-M -T	----- -----	M20x1.5 mm 1/2NPT (*9)
Instruction manual	-E -K	----- -----	English Korea (*16)
--	-A	-----	Always -A
Options	Valves	/C	Inconel bolt (*2)
		/CV /SV	Check valve (*3) Stop valve (*3)
		/H	Hood (*6)
	Tag plates	/SCT /PT	Stainless steel tag plate (*4) Printed tag plate (*4)
		NAMUR NE43 compliant	/C2
	/C3		Failure alarm up-scale: Output status at CPU failure and hardware error is 21.0 mA or more (*12)

*1 The thickness of the flange depends on its dimensions.

*2 Inconel probe bolts and U shape pipe are used. Use this option for high temperature use (ranging from 600 to 700°C).

*3 Specify either /CV or /SV option code.

*4 Specify either /SCT or /PT option code.

*5 No need to specify the option codes, /CV and /SV, since the check valves are provided with the Automatic Calibration Unit.

*6 Sun shield hood is still effective even if scratched. Hood is necessary for outdoor installation out of sun shield roof.

*7 Recommended if sample gas contains corrosive gas like chlorine.

*8 Piping for reference gas must be installed to supply reference gas constantly at a specified flow rate.

*9 When selecting code -B (FM certified explosion-proof) or -C (CSA certified explosion-proof), select code -T (1/2 NPT).

*10 Confirm inside diameter of pipe attached to customer's flange in case that -A or -E is selected.

*11 The cable entry devices (cable glands etc.) and blind plugs shall be in type of protection Ex "db" or Ex "tb", suitable for the conditions of use and correctly installed. They shall provide a degree of ingress protection of at least IP66.

*12 Output signal limits: 3.8 to 20.5 mA. Specify either /C2 or /C3 option code.

*13 When using ZR202S as CE marking compliance product, select -A (ATEX certified flameproof).

*14 "-Q" is the explosion-proof type of EAC with Pattern Approval for Russia. "-R" is the explosion-proof type of EAC for Kazakhstan and Belarus.

*15 Product registration is done by Yokogawa Taiwan Corporation as an importer in Taiwan.

*16 When selecting code -K (KOSHA certified explosion-proof)

● Standard Accessories

Item	Parts No.	Q'ty	Description	Item	Parts No.	Q'ty	Description
Fuse	A1113EF	1	3.15A	Allen wrench	L9827AB	1	For lock screw

External Dimensions

● ZR202S Integrated type Explosion-proof Zirconia Oxygen Analyzers

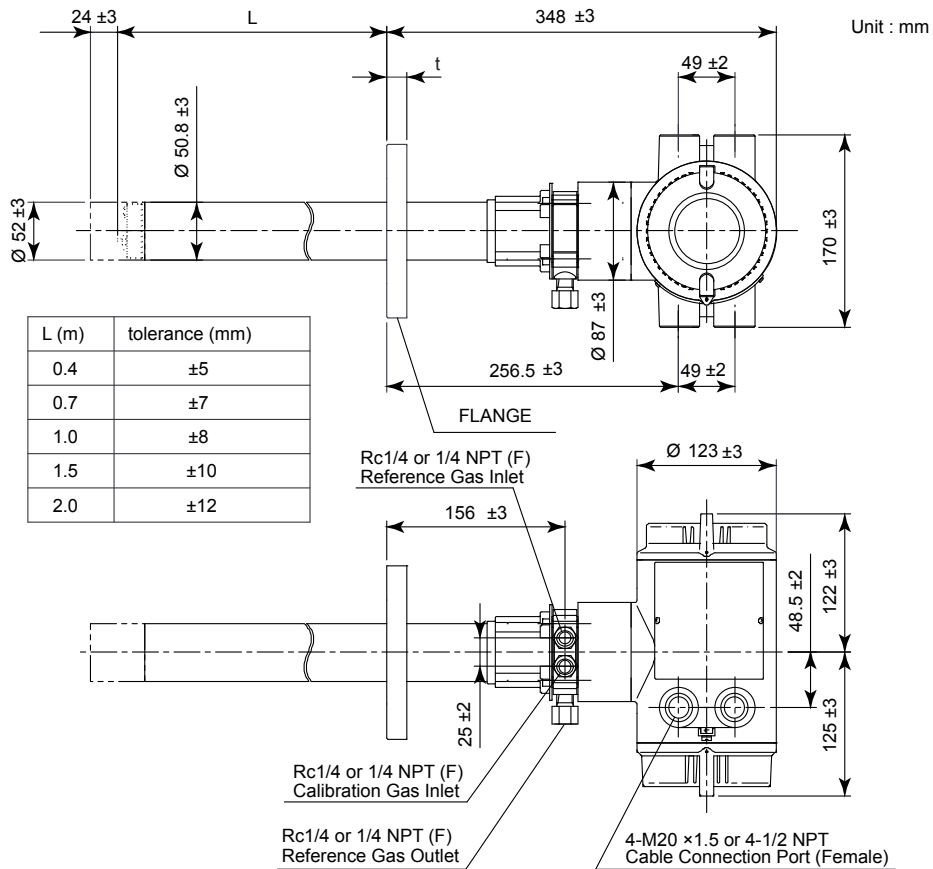

L (m)	tolerance (mm)
0.4	±5
0.7	±7
1.0	±8
1.5	±10
2.0	±12

Flange	A	B	C	t
ANSI Class 150 2 RF	152.4	120.6	4 - Ø19	19
ANSI Class 150 3 RF	190.5	152.4	4 - Ø19	24
ANSI Class 150 4 RF	228.6	190.5	8 - Ø19	24
DIN PN10 DN50	165	125	4 - Ø18	18
DIN PN10 DN80	200	160	8 - Ø18	20
DIN PN10 DN100	220	180	8 - Ø18	20
JIS 5K 65 FF	155	130	4 - Ø15	14
JIS 10K 65 FF	175	140	4 - Ø19	18
JIS 10K 80 FF	185	150	8 - Ø19	18
JIS 10K 100 FF	210	175	8 - Ø19	18
JPI Class 150 4 RF	229	190.5	8 - Ø19	24
JPI Class 150 3 RF	190	152.4	4 - Ø19	24
Westinghouse	155	127	4 - Ø11.5	14

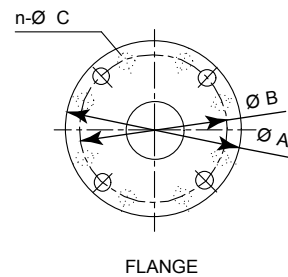

F2-1E.ai

External Dimensions

With Automatic Calibration Unit (Horizontal Mount)

Unit : mm

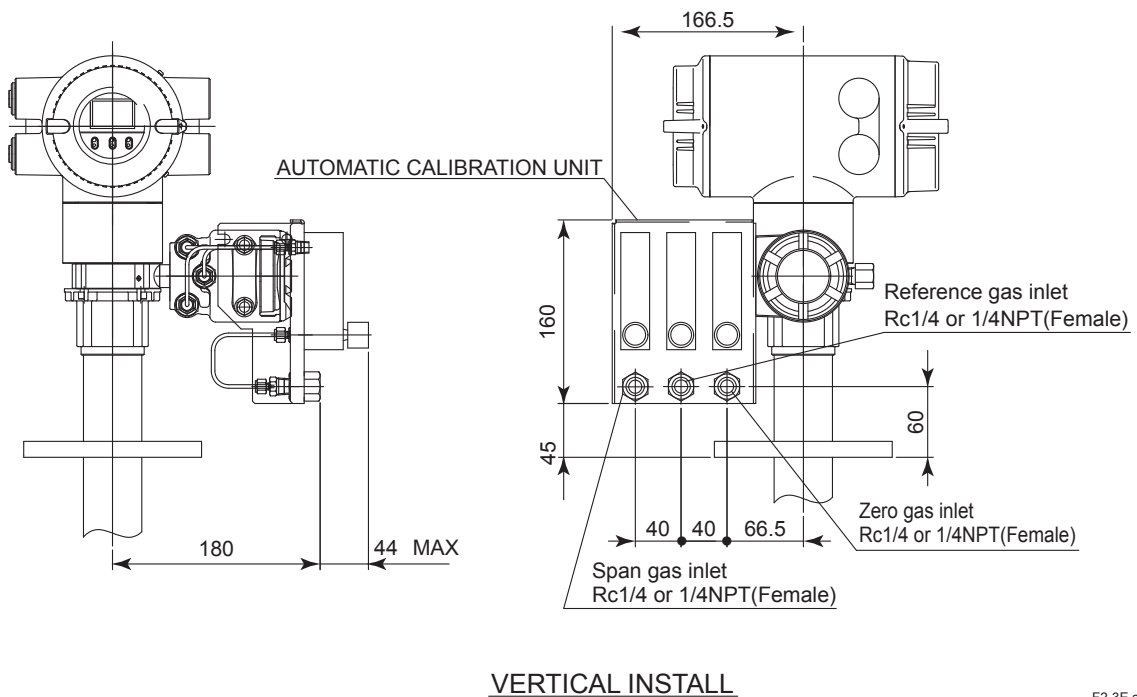
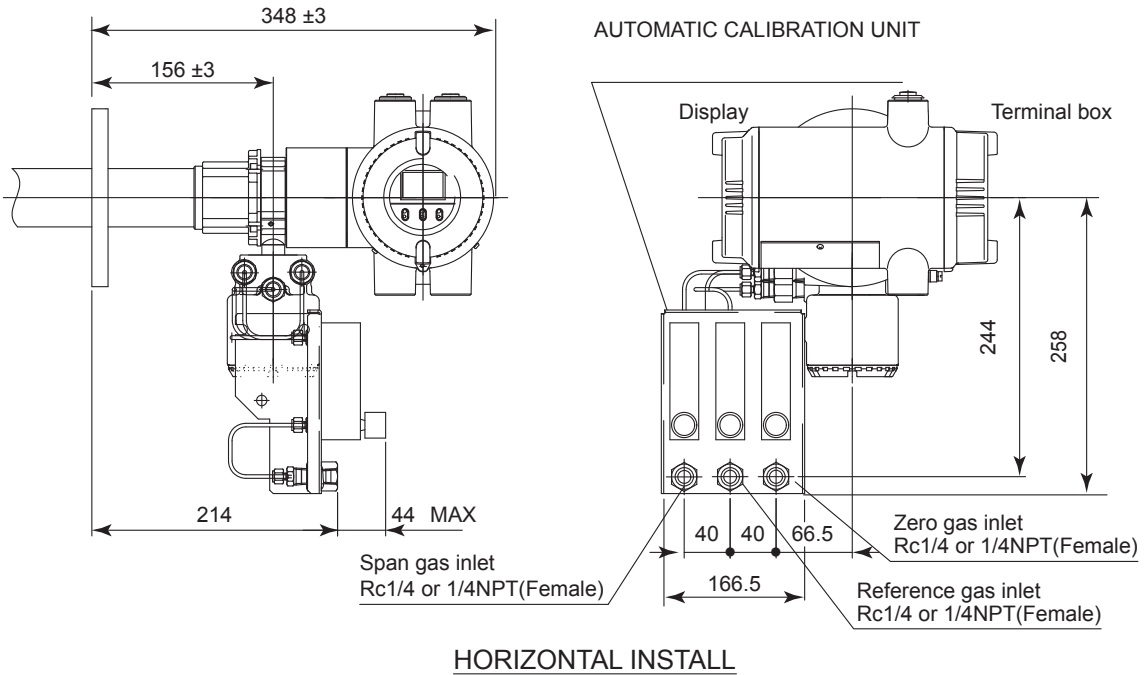

Standard Accessories

Item	Parts. No.	Q'ty	Description
Fuse	A1113EF	1	3.15 A
Allen wrench	L9827AB	1	For lock screw

F2-3E.ai

● With sun shield hood (option code /H)

Unit : mm

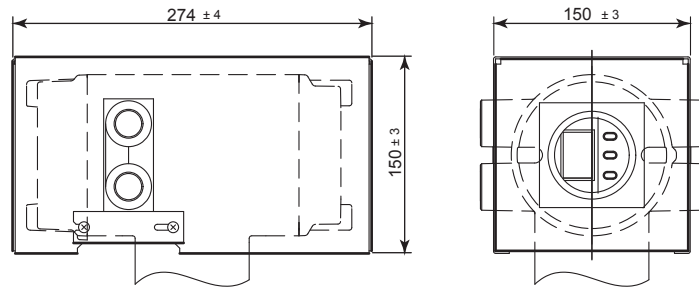

Material of hood : Aluminum

F2-2E.ai

● Check Valve (option code /CV), Stop valve (option code /SV) -specified Calibration gas inlet

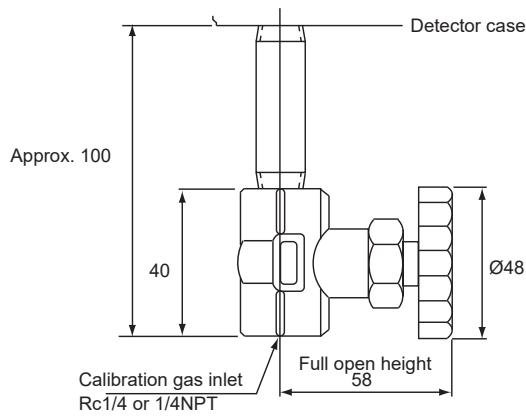

with Stop Valve (option: /SV)

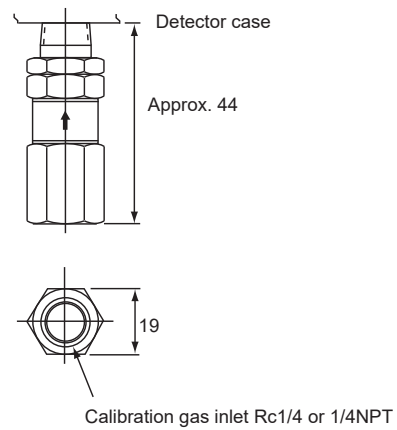

with Check Valve (option: /CV)

2.1.3 ZO21R Probe Protector

Used when sample gas flow velocity is approx. 10 m/sec or more and dust particles wears the detector in cases such as pulverized coal boiler or fluidized bed furnace (or burner) to protect the detector from wearing by dust particles.

Insertion Length: 1.05, 1.55, 2.05 m.

Flange: JIS 5K 65A FF equivalent. ANSI Class 150 4 FF (without serration) equivalent . However, flange thickness is different.

Material: 316 SS (JIS), 304 SS (JIS) or ASTM grade 304 (Flange)

Weight: 1.05 m; Approx. 6/10 kg (JIS/ANSI),
 1.55 m; Approx. 9/13 kg (JIS/ANSI),
 2.05 m; Approx. 12/16 kg (JIS/ANSI)

Installation: Bolts, nuts, and washers are provided for detector, probe protector and process-side flange.

● Model and Codes

Model	Suffix code	Option code	Description
ZO21R	-L	-----	Probe Protector(0 to 700°C)
Insertion length	-100	-----	1.05 m (3.5 ft)
	-150	-----	1.55 m (5.1 ft)
	-200	-----	2.05 m (6.8 ft)
Flange (*1)	-J	-----	JIS 5K 65 FF
	-A	-----	ANSI Class 150 4 FF
Style code	*B	-----	Style B

*1 Thickness of flange depends on dimensions of flange.

Unit: mm

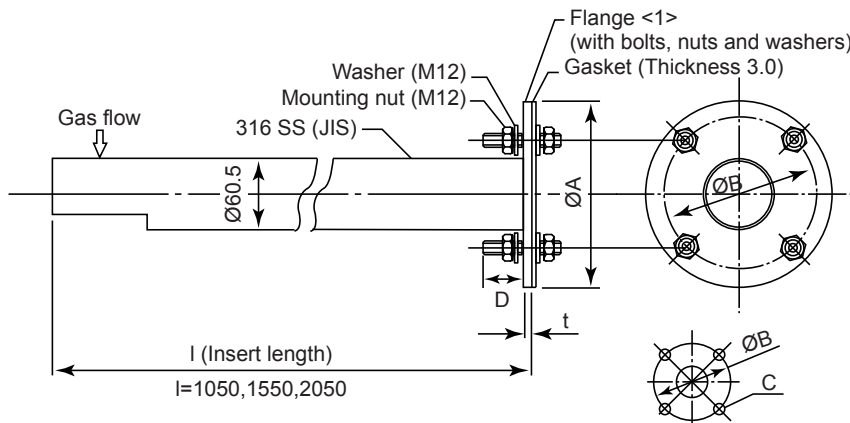

Dimensions of holes on opposing surface

F2-4E.ai

Flange<1>	A	B	C	t	D
JIS 5K 65 FF	155	130	4 - Ø15	5	40
ANSI Class 150 4 FF	228.6	190.5	8 - Ø19	12	50

2.2 ZA8F Flow Setting Unit

■ ZA8F Flow Setting Unit

This flow setting unit is applied to the reference gas and the calibration gas in a system configuration (System 1). Used when instrument air is provided.

This unit consists of a flowmeter and flow control valves to control the flow rates of calibration gas and reference gas.

● Standard Specifications

Construction:	Dust-proof and rainproof construction
Case Material:	SPCC (Cold rolled steel sheet)
Flowmeter Scale:	Calibration gas; 0.1 to 1.0 L/min. Reference gas; 0.1 to 1.0 L/min.
Painting:	Baked epoxy resin, Dark-green (Munsell 2.0 GY 3.1/0.5 or equivalent)
Tube Connections:	Rc1/4 or 1/4FNPT
Reference Gas Pressure:	Clean air supply of sample gas pressure plus approx. 50 kPaG (or sample gas pressure plus approx. 150 kPaG when a check valve is used). Pressure at inlet of the Flow Setting Unit. (Maximum 300 kPaG)
Reference Gas Consumption:	Approx. 1.5 L/min
Calibration Gas (zero gas, span gas) Consumption:	Approx. 0.7 L/min (at calibration time only)
Weight:	Approx. 2.3 kg

NOTE

Use instrument air for span calibration gas, if no instrument air is available, contact YOKOGAWA.

● Model and Codes

Model	Suffix code	Option code	Description
ZA8F	-----	-----	Flow setting unit
Joint	-J -A	----- -----	Rc 1/4 With 1/4 NPT adapter
Style code	*C	-----	Style C

● External Dimensions

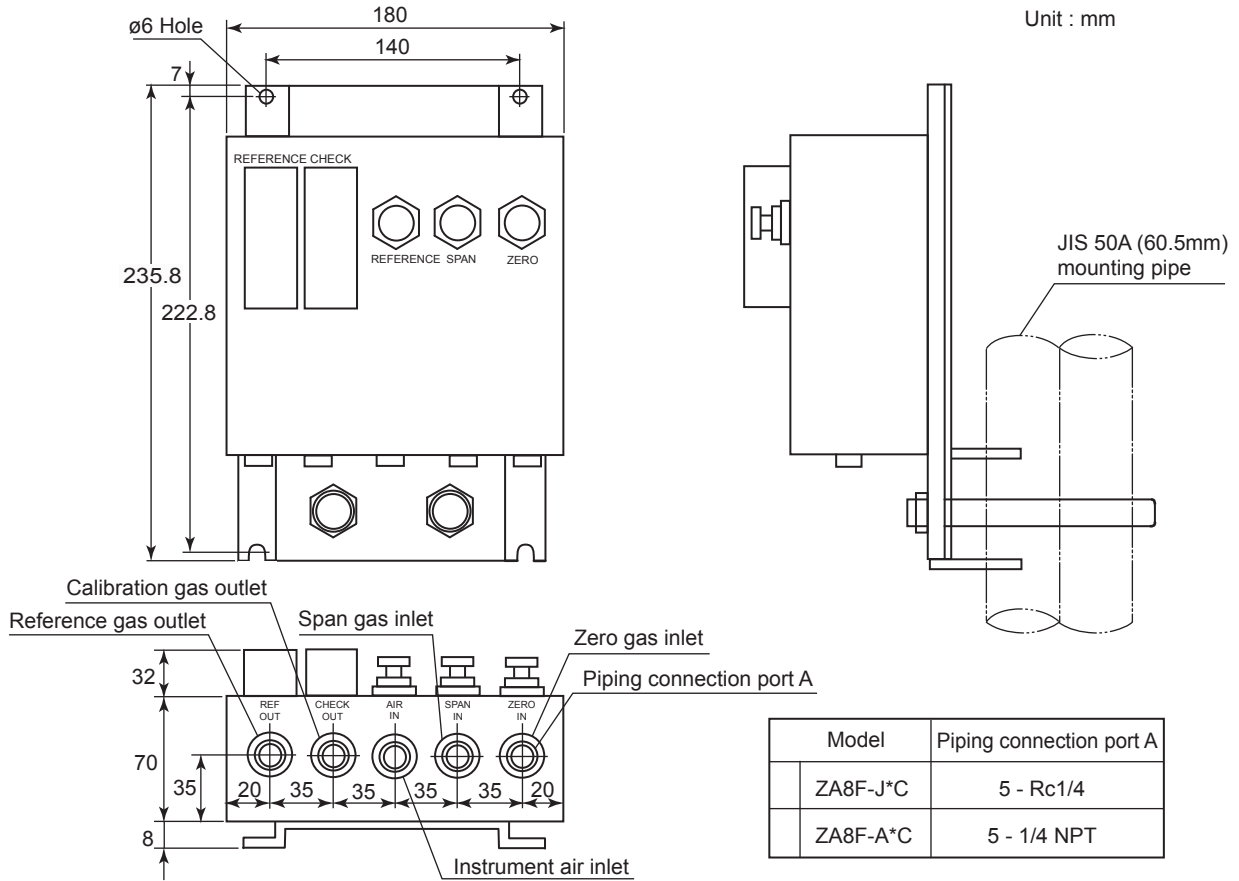

Weight : Approx. 2.3 kg

PIPING INSIDE THE FLOW SETTING UNIT

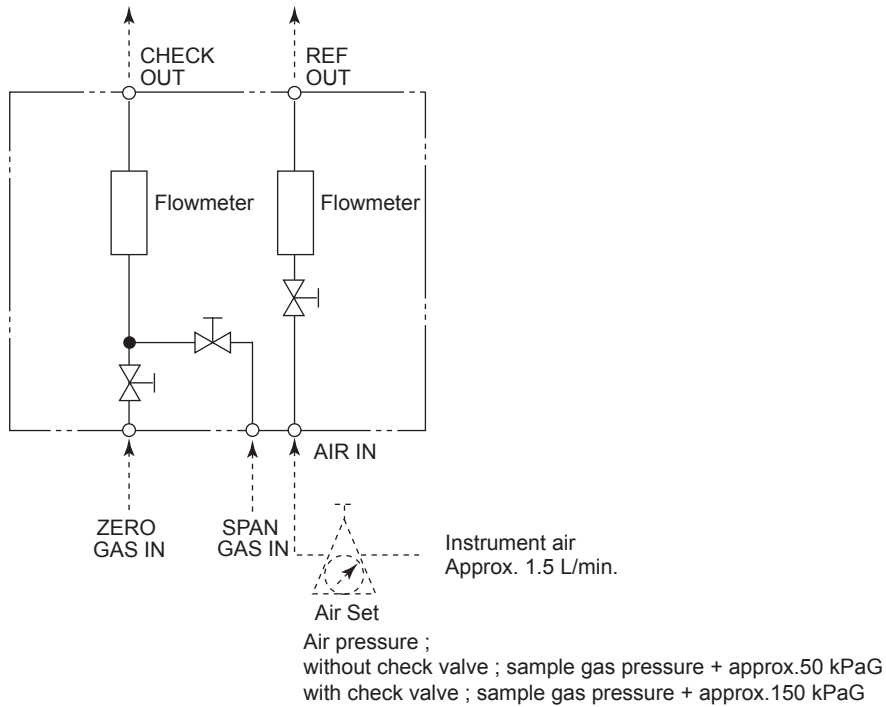

F2-5E.ai

2.3 ZO21S Standard Gas Unit

CAUTION

Standard Gas Unit (Model ZO21S) must not be located in hazardous area.

This is a handy unit to supply zero gas and span gas to the detector as calibration gas. It is used in combination with the detector only during calibration.

The ZO21S does not conform to CE marking.

● Standard Specifications

Function: Portable unit for calibration gas supply consisting of span gas (air) pump, zero gas cylinder with sealed inlet, flow rate checker and flow rate needle valve.

Sealed Zero Gas Cylinders (6 provided): E7050BA

Capacity: 1 l

Filled pressure: Approx. 686 kPaG (at 35°C)

Composition: 0.95 to 1.0 vol%O₂ + N₂ balance

Power Supply: 100, 110, 115, 200, 220, 240 V AC ±10%, 50/60 Hz

Power Consumption: Max. 5 VA

Case material: SPCC (cold rolled steel sheet)

Paint Color: Mainframe; Munsell 2.0 GY3.1/0.5 equivalent
Cover; Munsell 2.8 GY6.4/0.9 equivalent

Piping: Ø6 x Ø4 mm flexible tube connection

Weight: Approx. 3 kg

● Model and Codes

Model	Suffix code	Option code	Description
ZO21S	-----	-----	Standard gas unit
Power supply	-2	-----	200 V AC 50/60 Hz
	-3	-----	220 V AC 50/60 Hz
	-4	-----	240 V AC 50/60 Hz
	-5	-----	100 V AC 50/60 Hz
	-7	-----	110 V AC 50/60 Hz
	-8	-----	115 V AC 50/60 Hz
Panel	-J	-----	Japanese version
	-E	-----	English version
Style code		*A	Style A

● External Dimensions

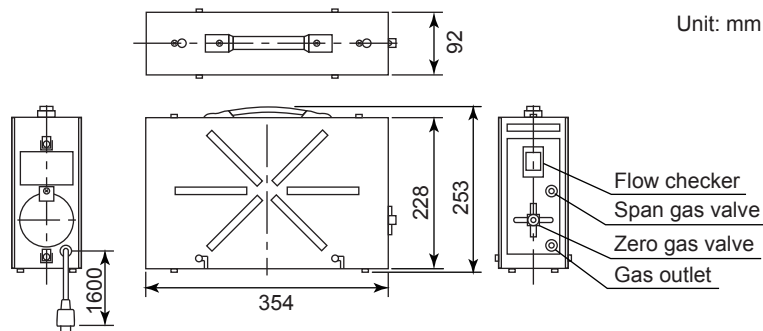

Zero gas cylinder (6 cylinder): E7050BA

F2-6E.ai

2.4 Other Equipment

2.4.1 Stop Valve (L9852CB, G7016XH)

This valve mounted on the calibration gas line in the system using ZA8F flow setting unit for manual calibration.

● Standard Specifications

Material: 316 SS (JIS)
 Connection: Rc 1/4 or 1/4 FNPT
 Weight: Approx. 200 g

Part No.	Description
L9852CB	Joint: Rc 1/4, Material: 316 SS (JIS)
G7016XH	Joint: 1/4 FNPT, Material: 316 SS (JIS)

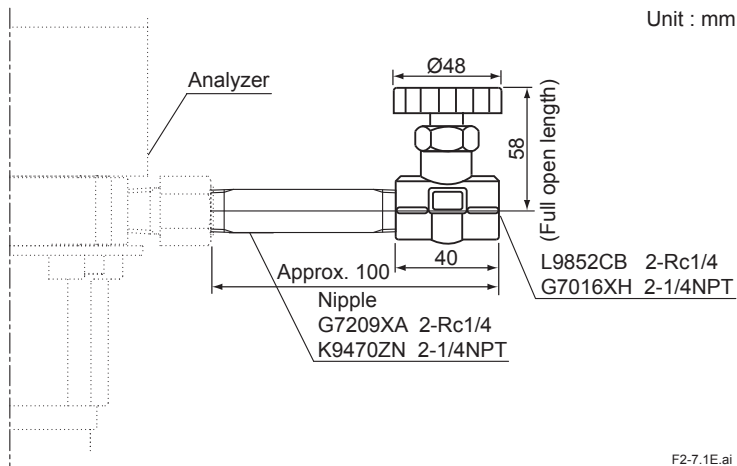

2.4.2 Check Valve (K9292DN, K9292DS)

This valve is mounted on the calibration gas line (directly connected to the detector). This valve prevents the sample gas from entering the calibration gas line. Although it functions as a stop valve, operation is easier than a stop valve as it does not require opening/closing at each calibration. Screw a check valve, instead of a stop valve into the calibration gas inlet of the detector.

● Standard Specifications

Material: 304 SS (JIS)
 Connection: Rc1/4 or 1/4 FNPT
 Pressure: 150 kPaG or more and 350 kPaG or less
 Weight: Approx. 90 g

Part No.	Description
K9292DN	Joint: Rc 1/4, Material: 304 SS (JIS)
K9292DS	Joint: 1/4 FNPT, Material: 304 SS (JIS)

K9292DN : Rc 1/4(A),R 1/4(B) Unit: mm
 K9292DS : 1/4 FNPT(A),1/4 NPT(Male)(B)

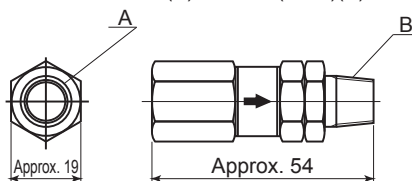

2.4.3 Air Set

This set is used to lower the pressure when instrument air is used as the reference and span gases.

● Standard Specifications

• G7003XF, K9473XK

Primary Pressure: Max. 1 MPaG
 Secondary Pressure: 0.02 to 0.2 MPaG
 Connection: Rc1/4 or 1/4 FNPT (with joint adapter)
 Weight: Approx. 1 kg

Part No.	Description
G7003XF	Joint: Rc 1/4, Material: Zinc alloy
K9473XK	Joint: 1/4 FNPT (with joint adapter), Material: Zinc alloy, Adapter: 316 SS (JIS)

• G7004XF, K9473XG

Primary Pressure: Max. 1 MPaG
 Secondary Pressure: 0.02 to 0.5 MPaG
 Connection: Rc1/4 or 1/4 FNPT with joint adapter
 Weight: Approx. 1 kg

Part No.	Description
G7004XF	Joint: Rc 1/4, Material: Zinc alloy
K9473XG	Joint: 1/4 FNPT (with joint adapter), Material: Zinc alloy, Adapter: 316 SS (JIS)

● External Dimensions

Unit : mm

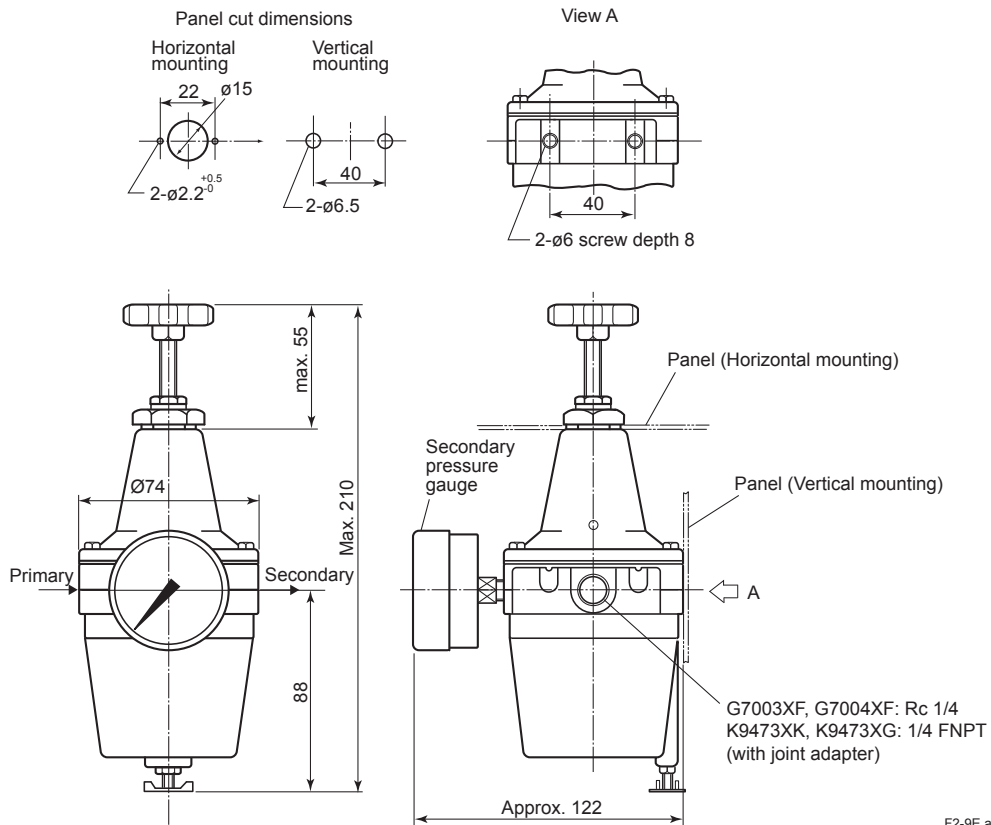

F2-9E.ai

2.4.4 Pressure Reducing Valve for Gas Cylinder (G7013XF, G7014XF)

This pressure reducing valve is used with the zero gas cylinders.

● Standard Specifications

Primary Pressure:	Max. 14.8 MPa G
Secondary Pressure:	0 to 0.4 MPa G
Connection:	Inlet; W22 14 threads, right hand screw Outlet; Rc1/4 or 1/4 FNPT
Material:	Brass body

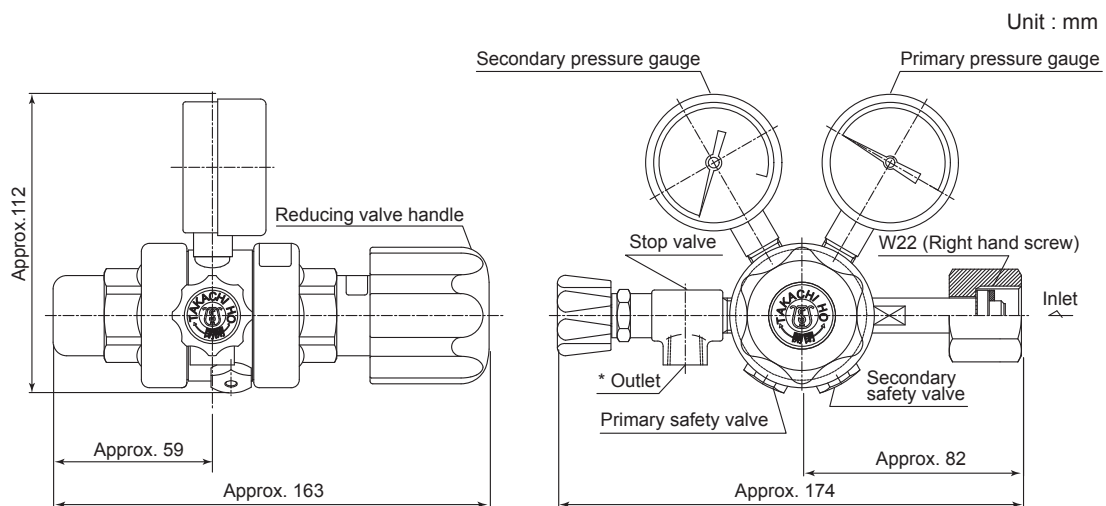

Part No.	* Outlet
G7013XF	Rc1/4
G7014XF	1/4 NPT female with adapter

F2-10E.ai

2.4.5 ZR202A Heater Assembly

● Model and Codes

Model	Suffix code	Option code	Description
ZR202A	-----	-----	Heater Assembly for ZR202S
Length (*1)	-040	-----	0.4 m
	-070	-----	0.7 m
	-100	-----	1 m
	-150	-----	1.5 m
	-200	-----	2 m
Jig for change	-A	-----	with Jig
	-N	-----	None
—	-A	-----	Always-A

*1 Suffix code of length should be selected as same as ZR202S installed.
 (Note) The heater is made of ceramic, do not drop or subject it to pressure stress.

● External Dimensions

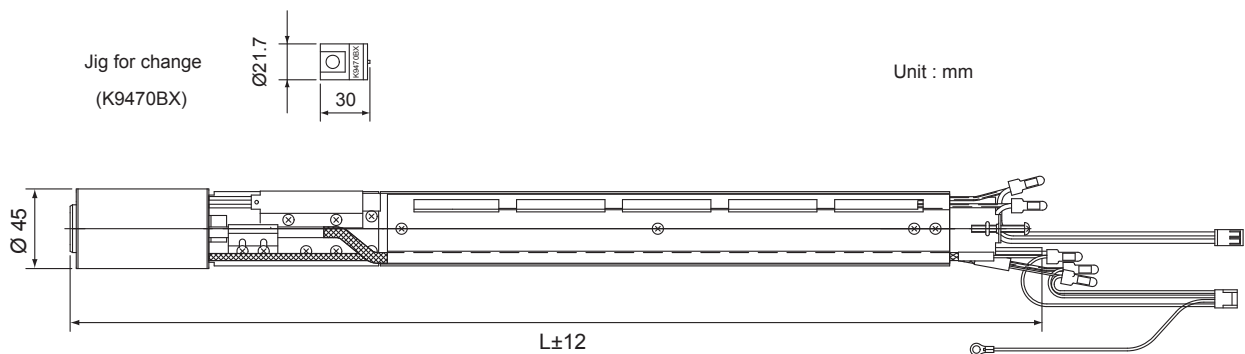

Model & Codes	L	Weight (kg)
ZR202A-040	552	Approx. 0.8
ZR202A-070	852	Approx. 1.2
ZR202A-100	1152	Approx. 1.6
ZR202A-150	1652	Approx. 2.2
ZR202A-200	2152	Approx. 2.8

F2-11E.ai

3. Installation

This chapter describes installation of the following equipment:

- 3.1 Model ZR202S Integrated type Explosion-proof Zirconia Oxygen Analyzer
- 3.2 Model ZA8F Flow Setting Unit
- 3.3 Case Assembly (E7044KF) for Calibration gas Cylinder

3.1 Installation of ZR202S Zirconia Oxygen Analyzer

3.1.1 Installation Location

The following should be taken into consideration when installing the analyzer:

- (1) Easy and safe access to the analyzer for checking and maintenance work.
- (2) Ambient temperature of not more than 55°C, and the terminal box should not be affected by radiant heat.
- (3) A clean environment without any corrosive gases.
- (4) No vibration.
- (5) The sample gas satisfies the specifications described in Chapter 2.
- (6) No sample gas pressure fluctuations.
- (7) The installation must be in accordance with IEC 60079-14 and relevant local codes.



CAUTION

The ambient temperature of the ZR202S Integrated type Explosion-proof Zirconia Oxygen Analyzer should be between -20°C and 55°C.

3.1.2 ATEX Flameproof Type

ZR202S–A Analyzer for use in hazardous area:

Note 1: Applicable Standard: EN IEC 60079-0: 2018, EN 60079-1: 2014, EN 60079-31: 2014

Certificate Number: KEMA 04ATEX2156 X

The symbol "X" placed after certificate number indicates that the equipment is subjected to special conditions for safe use. Refer to Note 6.

Type of protection: Ex db IIB+H₂ T2 Gb, Ex tb IIIC T300°C Db

Equipmant Group: II

Category: 2GD

Temperature class for Ex "db": T2

The maximum surface temperature for Ex "tb": T300°C

Degree of protection of enclosure: IP66

Note 2: Wiring

- All wiring shall comply with local installation requirement.

Note 3: Operation

- Keep to "WARNING" on the Analyzer.

**WARNING: DO NOT OPEN WHEN AN EXPLOSIVE GAS ATMOSPHERE IS PRESENT
POTENTIAL ELECTROSTATIC CHARGING HAZARD-READ USER'S MANUAL (IM11M13A01-04)
FOR INSTALLATION AND SAFE USE, READ IM11M13A01-04
USE AT LEAST 80°C HEAT RESISTANT CABLES & CABLE GLANDS**

- Take care not to generate mechanical sparking when accessing to the analyzer and peripheral devices in hazardous area.

Note 4: Maintenance and Repair

- The analyzer modification or parts replacement by other than authorized representative of Yokogawa Electric Corporation is prohibited and will void the certification.

Note 5: Cable Entry

- The threaded type of cable entry is marked beside the cable entry according to the following markings.

Threaded type	:	Marking
M20x1.5	:	M
1/2 NPT	:	N

- The cable entry devices (cable glands etc.) and blind plugs shall be in type of protection Ex "db" or Ex "tb", suitable for the conditions of use and correctly installed. They shall provide a degree of ingress protection of at least IP66.

Note 6: Special conditions for safe use

Electrostatic charge may cause an explosion hazard. Avoid any actions that cause the generation of electrostatic charge, such as rubbing with a dry cloth.

If it is mounted in the area where the use of Ex "tb" apparatus is required, it shall be installed in such a way that the risk from electrostatic discharges and propagating brush discharges caused by rapid flow of dust is avoided.

Note 7: Special fastener

Hexagon socket head cap screws below are special fastener according to EN IEC 60079-0: 2018 (see the figure below). Material property classes of them are A2-50 or better.

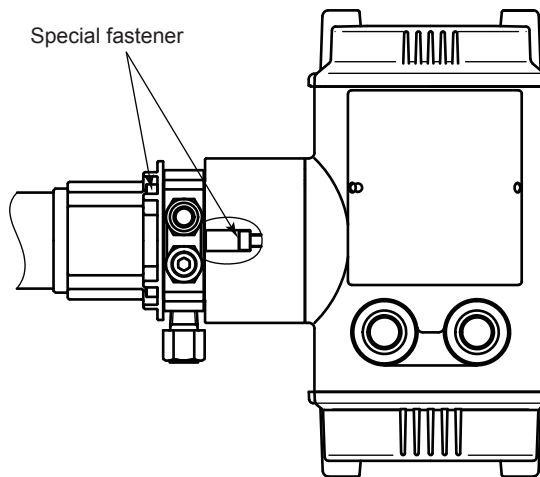

Figure 3.1 Special fastener

3.1.3 FM Explosion-proof Type

ZR202S-B Analyzer for use in hazardous area:

Note 1: Applicable Standard: FM3600 2011, FM3615 2006, FM3810 2005, ANSI/NEMA 250 1991

Type of protection: Explosion-proof for Class I, Division 1, Groups B, C and D

Dust-ignitionproof for Class II/III, Division 1, Groups E, F and G

Enclosure Rating: NEMA 4X

Temperature Class: T2

Note 2: Wiring

- All wiring shall comply with National Electrical Code ANSI/NEPA 70 and Local Electrical Code.
- In hazardous area, wiring shall be in conduits as shown in the figure.

WARNING: SEAL ALL CONDUITS WITHIN 18 INCHES OF THE ENCLOSURE.

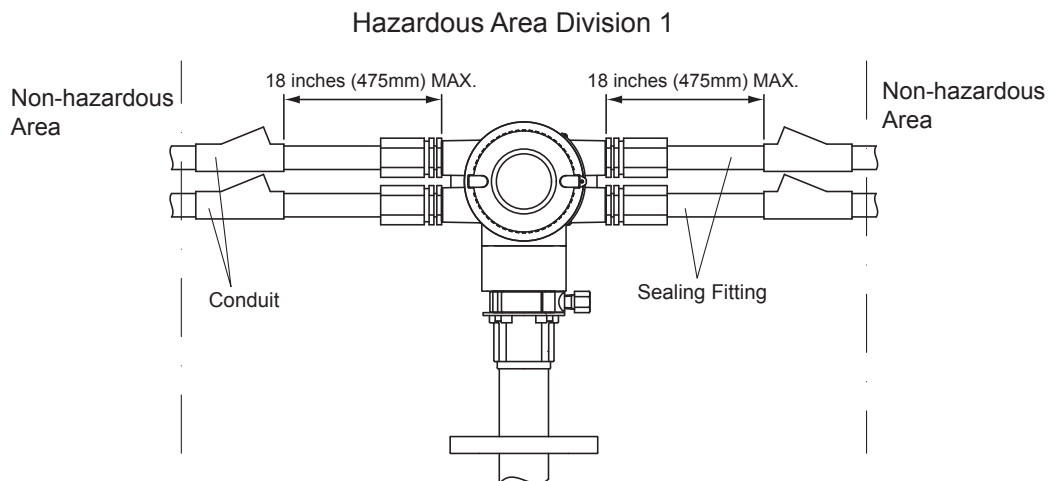

Figure 3.2 Wiring of ZR202S-B

F3-1E.ai

Note 3: Operation

- Keep the "WARNING" label to the Analyzer.

WARNING: OPEN CIRCUIT BEFORE REMOVING COVER. INSTALL IN ACCORDANCE WITH THE INSTRUCTION MANUAL IM 11M13A01-04E. USE AT LEAST 80°C HEAT RESISTANT CABLES.

- Take care not to generate mechanical sparking when accessing to the analyzer and peripheral devices in hazardous area.

Note 4: Maintenance and Repair

- The analyzer modification or parts replacement by other than authorized representative of Yokogawa Electric Corporation is prohibited and will void Factory Mutual Explosion-proof Approval.

3.1.4 CSA Explosion-proof Type

ZR202S-C Analyzer for use in hazardous area:

Note 1: Applicable Standard: C22.2 No.0-M1991, C22.2 No.0.4-04, C22.2 No.0.5-1982, C22.2 No.25-1966, C22.2 No.30-M1986, C22.2 No.94-M91, C22.2-No.61010-1-04

Certificate Number: 1649642

Type of protection: Explosion-proof for Class I, Division 1, Groups B, C and D

Dust-ignitionproof for Class II/III, Division 1, Groups E, F and G

Enclosure: Type 4X

Temperature Class: T2

Note 2: Wiring

- All wiring shall comply with Canadian Electrical Code Part 1 and Local Electrical Code.
- In hazardous area, wiring shall be in conduits as shown in the figure.

WARNING: SEAL ALL CONDUITS WITHIN 50 cm OF THE ENCLOSURE.
UN SELLE DOIT ÊTRE INSTALLÉ À MOINS DE 50 cm DU BÎTIER.

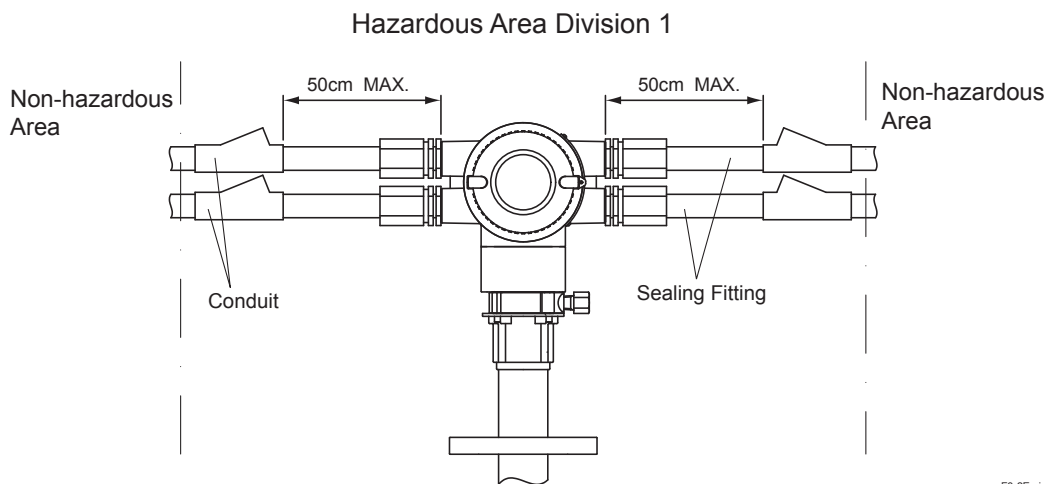

Figure 3.3 Wiring of ZR202S-C

Note 3: Operation

- Keep the “WARNING” label to the Analyzer.

WARNING: OPEN CIRCUIT BEFORE REMOVING COVER. REFER TO IM 11M13A01-04E. USE AT LEAST 80°C HEAT RESISTANT CABLES.

OUVRIER LE CIRCUIT AVANT D'ENLEVER LE COUVERCLE. UTILISEZ DES CÂBLES RÉSISTANTS À 80°C MINIMUM. VEUILLEZ VOUS RÉFÉRER AU IM 11M13A01-04E.

- Take care not to generate mechanical sparking when accessing to the analyzer and peripheral devices in hazardous area.

Note 4: Maintenance and Repair

- The analyzer modification or parts replacement by other than authorized representative of Yokogawa Electric Corporation is prohibited and will void Canadian Standards Explosion-proof Certification.

3.1.5 IECEx Flameproof Type

ZR202S–D Analyzer for use in hazardous area:

Note 1: IECEx flameproof type

Applicable Standard: IEC 60079-0: 2011, IEC 60079-1: 2014, IEC 60079-31: 2013

Certificate Number: IECEx KEM 06.0006X

The symbol "X" placed after certificate number indicates that the equipment is subjected to special conditions for safe use. Refer to Note 6.

Type of protection: Ex db IIB + H2 Gb,
Ex tb IIIC T300°C Db

Temperature class for Ex "db": T2

The maximum surface temperature for Ex "tb": T300°C

Degree of protection of enclosure: IP66

Note 2: Wiring

- All wiring shall comply with local installation requirement.

Note 3: Operation

- Keep to "WARNING" on the Analyzer.

**WARNING: DO NOT OPEN WHEN AN EXPLOSIVE GAS ATMOSPHERE IS PRESENT
POTENTIAL ELECTROSTATIC CHARGING HAZARD-READ USER'S MANUAL (IM11M13A01-04)
FOR INSTALLATION AND SAFE USE, READ IM11M13A01-04
USE AT LEAST 80°C HEAT RESISTANT CABLES & CABLE GLANDS**

- Take care not to generate mechanical sparking when accessing to the analyzer and peripheral devices in hazardous area.

Note 4: Maintenance and Repair

- The analyzer modification or parts replacement by other than authorized representative of Yokogawa Electric Corporation is prohibited and will void the certification.

Note 5: Cable Entry

- The threaded type of cable entry is marked beside the cable entry according to the following markings.

Threaded type	:	Marking
M20x1.5	:	M
1/2 NPT	:	N

- In case of ANSI 1/2 NPT plug, ANSI hexagonal wrench should be applied to screw in.
- The cable entry devices (cable glands etc.) and blind plugs shall be in type of protection Ex “db” or Ex “tb”, suitable for the conditions of use and correctly installed. They shall provide a degree of ingress protection of at least IP66.

Note 6: Special conditions for safe use

Electrostatic charge may cause an explosion hazard. Avoid any actions that cause the generation of electrostatic charge, such as rubbing with a dry cloth.

If it is mounted in the area where the use of Ex “tb” apparatus is required, it shall be installed in such a way that the risk from electrostatic discharges and propagating brush discharges caused by rapid flow of dust is avoided.

Note 7: Special fastener

Hexagon socket head cap screws below are special fastener according to IEC 60079-0: 2011 (see the figure below). Material property classes of them are A2-50 or better.

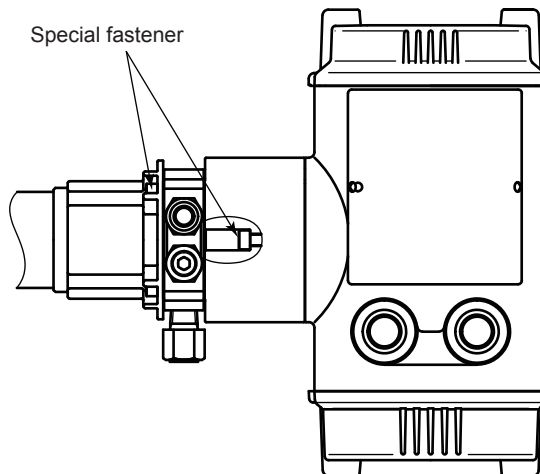

Figure 3.4 Special fastener

3.1.6 Probe (Detector) Insertion Hole

CAUTION

- The outside dimension of the probe may vary depending on its options. Use a pipe that is large enough for the probe. Refer to Subsection 2.1.2 for the dimensions.
- If the probe is mounted horizontally, the calibration gas inlet and reference gas inlet should face downwards.
- The sensor (zirconia cell) at the probe tip may deteriorate due to thermal shock if water drops are allowed to fall on it, as it is always at high temperature.

- (1) Do not mount the probe with the tip higher than the probe base.
- (2) The probe should be mounted at right angles to the sample gas flow or the probe tip should point downstream.

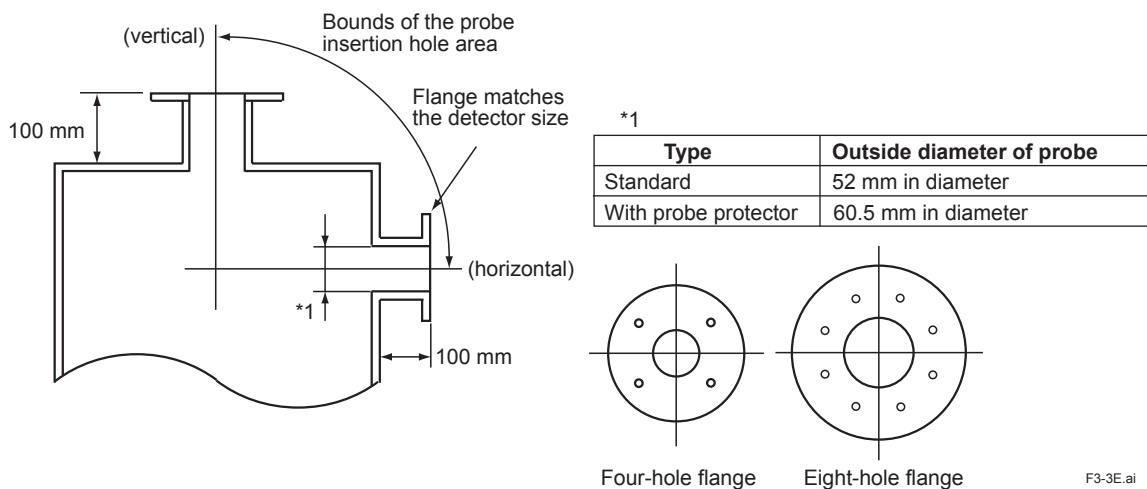

Figure 3.5 Example of forming probe insertion hole

3.1.7 Installation of the Probe (Detector)

CAUTION

- The cell (sensor) at the tip of the probe is made of ceramic (zirconia). Do not drop the probe, as impact will damage it.
- A gasket should be used between the flanges to prevent gas leakage. The gasket material should be heatproof and corrosion-proof, suited to the characteristics of the sample gas.

The following should be taken into consideration when mounting the probe:

- (1) Make sure that the cell mounting screws (four bolts) at the probe tip are not loose.
- (2) Where the probe is mounted horizontally, the calibration gas inlet and the reference gas inlet should face downward.

3.1.8 Installation of the Probe Protector (ZO21R)

<Analyzer with a probe protector (Model ZO21R-L-□□□□ *B for dust wear protect)>

The probe of the analyzer is used with a probe protector to prevent the sensor from being worn by dust particles when there is a high concentration of dust and gas flow exceeds 10 m/s (fine-carbon boiler or fluid bed furnace).

- (1) Put the gasket that is provided by user between the flanges, and mount the probe protector in the probe insertion hole. The probe protector should be installed so that the notch comes to the downstream of the sample gas flow.
- (2) Make sure that the sensor assembly mounting screws (four bolts) at the probe tip are not loose.
- (3) When the probe is mounted horizontally, the calibration gas and reference gas inlet should face downward.

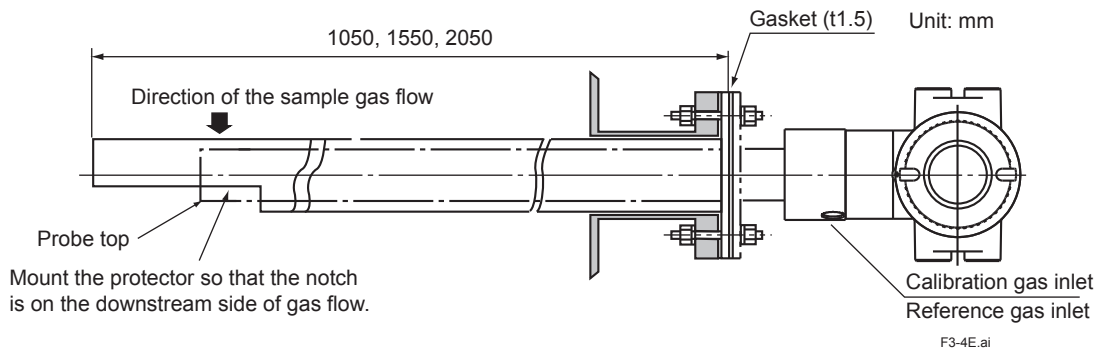

Figure 3.6 Mounting of probe with a probe protector (Dust wear protect)

3.2 Installation of ZA8F Flow Setting Unit

3.2.1 Installation Location

The following should be taken into consideration:

- (1) Easy access to the unit for checking and maintenance work.
- (2) Near to the analyzer
- (3) No corrosive gas.
- (4) An ambient temperature of not more than 55°C and little changes of temperature.
- (5) No vibration.
- (6) Little exposure to rays of the sun or rain.

3.2.2 Mounting of ZA8F Flow Setting Unit

The flow setting unit can be mounted either on a pipe (nominal JIS 50A) or on a wall. It should be positioned vertically so that the flowmeter works correctly.

<Pipe Mounting>

- (1) Prepare a vertical pipe of sufficient strength (nominal JIS 50A: O.D. 60.5 mm) for mounting the flow setting unit. (The unit weighs approximately 2 to 3.5 kg.)
- (2) Mount the flow setting unit on the pipe by tightening the nuts with the U-bolt so that the metal fitting is firmly attached to the pipe.

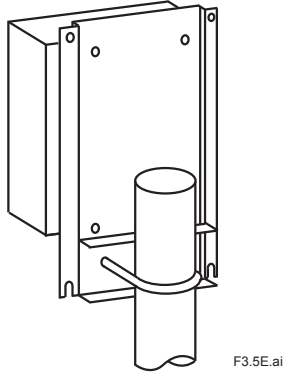

Figure 3.7 Pipe Mounting

<Wall Mounting>

- (1) Make a hole in the wall as illustrated in Figure 3.8.

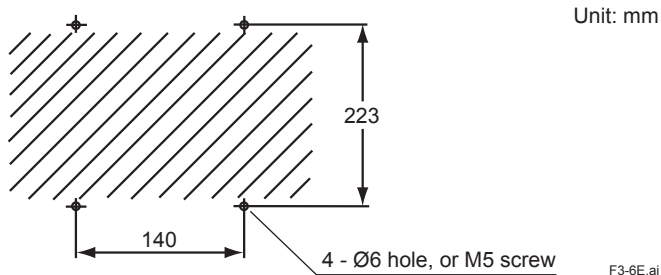

Figure 3.8 Mounting holes

- (2) Mount the flow setting unit. Remove the pipe mounting parts from the mount fittings of the flow setting unit and attach the unit securely on the wall with four screws.

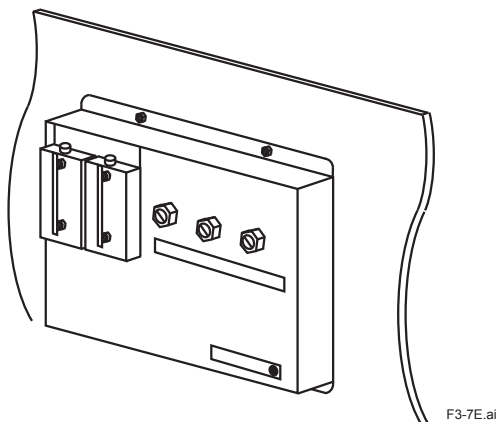

Figure 3.9 Wall mounting

3.3 Insulation Resistance Test

Even if the testing voltage is not so great that it causes dielectric breakdown, testing may cause deterioration in insulation and a possible safety hazard. Therefore, conduct this test only when it is necessary.

The applied voltage for this test shall be 500 V DC or less. The voltage shall be applied for as short a time as practicable to confirm that insulation resistance is 20 M Ω or more.

Remove wiring from the analyzer.

- (1) Remove the jumper plate located between terminal G and the protective grounding terminal.
- (2) Connect crossover wiring between L and N.
- (3) Connect an insulation resistance tester (with its power OFF). Connect (+) terminal to the crossover wiring, and (-) terminal to ground.
- (4) Turn the insulation resistance tester ON and measure the insulation resistance.
- (5) After testing, remove the tester and connect a 100 k Ω resistance between the crossover wiring and ground, to discharge.
- (6) Testing between the heater terminal and ground, contact output terminal and ground, analog output/input terminal and the ground can be conducted in the same manner.
- (7) Although contact input terminals are isolated, insulation resistance test cannot be conducted because the breakdown voltage of the surge-preventing arrestor between the terminal and ground is low.
- (8) After conducting all the tests, replace the jumper plate as it was.

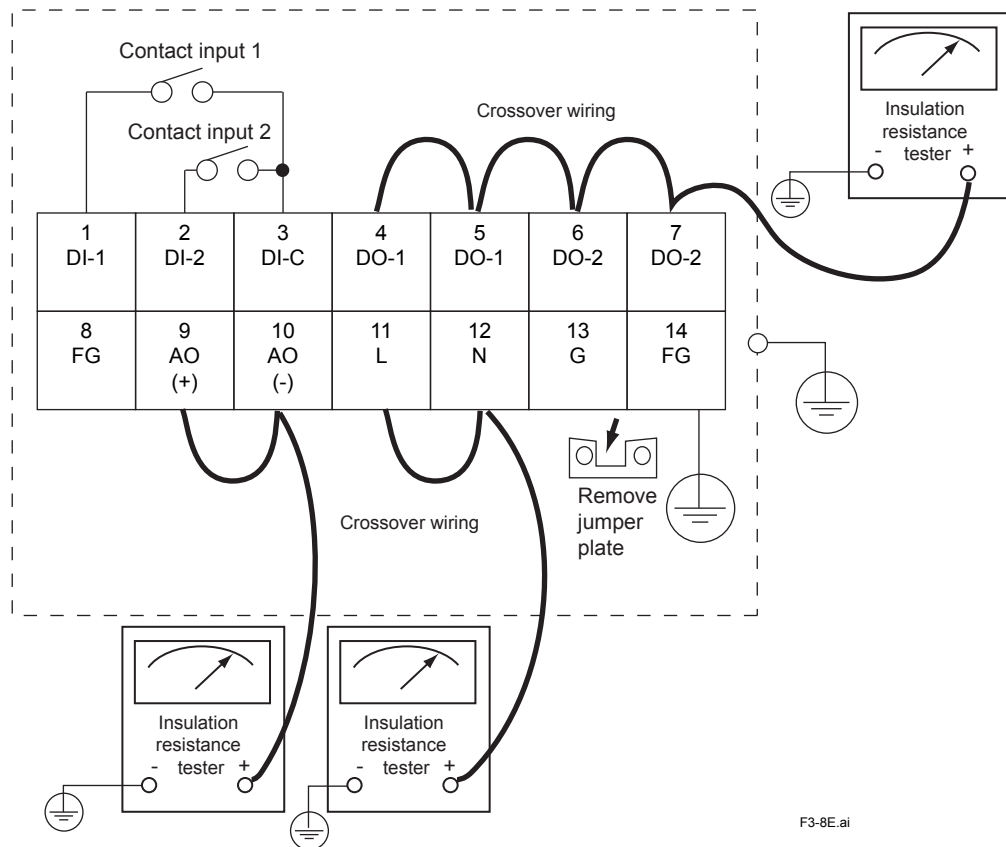

F3-8E.ai

Figure 3.10 Insulation Resistance Test

4. Piping

This chapter describes piping procedures in the two typical system configurations for EXAxt ZR Integrated type Explosion-proof Zirconia Oxygen Analyzer.

- Ensure that each check valve, stop valve and joints used for piping are not leaking. Especially, if there is any leakage at piping and joints for the calibration gas, it may cause clogging of the piping or incorrect calibration.
- Be sure to conduct leakage test after setting the piping.
- Basically, apply instrument air (dehumidified by cooling to the dew point -20°C or lower, and removing any dust, oil mist and the like) for the reference gas.

CAUTION

Do not loosen or remove any Flame Arrestor of gas inlet/outlet during piping.

The detector modification or parts replacement by other than authorized representative of Yokogawa Electric Corporation is prohibited and will void ATEX Certification, FM Approval, CSA Certification and IECEx Certification.

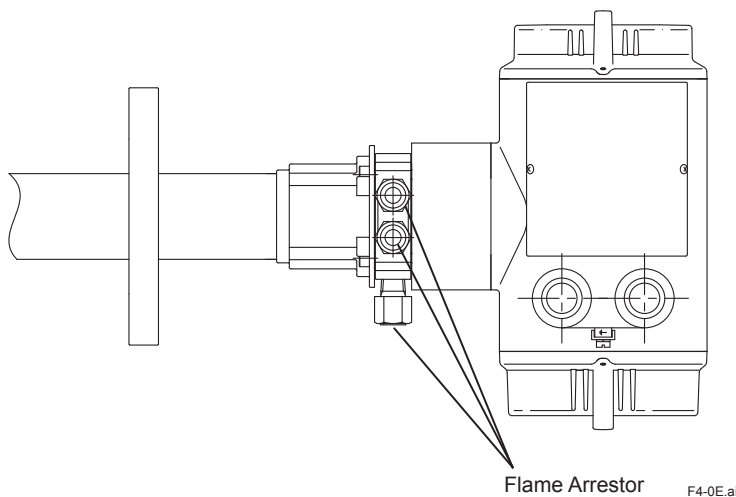

4.1 Piping for System 1

The piping in System 1 is illustrated in Figure 4.1

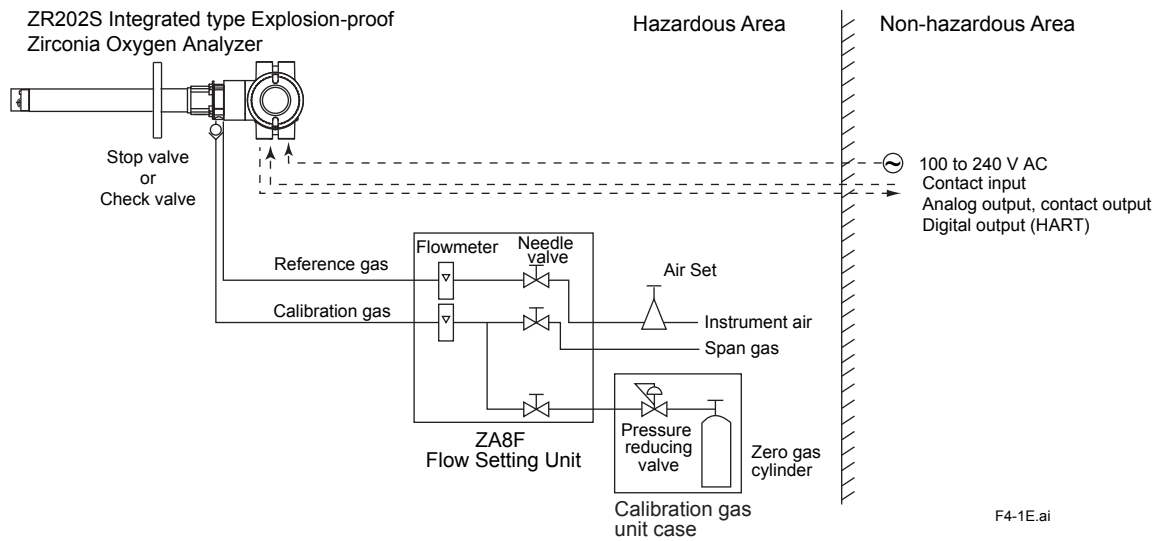

Figure 4.1 Piping for System 1

Piping in System 1 is as follows:

- Mount the check valve or the stop valve through a nipple to the calibration gas inlet of the equipment.

4.1.1 Piping Parts for System 1

Referring to Table 4.1, check that the parts required for your system are ready.

Table 4.1 Piping Parts

Equipment	Piping location	Parts Name	Description
Integrated type Explosion-proof Zirconia Oxygen Analyzer	Calibration gas inlet	Stop valve or check valve	Stop valve (L9852CB or G7016XH) recommended by YOKOGAWA Check valve (K9292DN or K9292DS) provided by YOKOGAWA
		Nipple *	R1/4 or 1/4 NPT General parts
		Zero gas cylinder	User's scope
		Pressure reducing valve	(G7013XF or G7014XF) recommended by YOKOGAWA
		Joint for tube connection *	R1/4 or 1/4 NPT General parts
	Reference gas inlet	Air set	(G7003XF/ K9473XK or G7004XF/ K9473XG) recommended by YOKOGAWA
		Joint for tube connection *	R1/4 or 1/4 NPT General parts

Note: Parts with marking * are used when required. General parts can be found on the local market.

4.1.2 Piping for the Calibration Gas Inlet

This piping is to be installed between the zero gas cylinder and the ZA8F flow setting unit, and between the ZA8F flow setting unit and the ZR202S analyzer.

The cylinder should be placed in a calibration gas unit case or the like to avoid any direct sunlight or radiant heat so that the gas cylinder temperature may not exceed 40°C. Mount the pressure reducing valve (recommended by YOKOGAWA) on the cylinder.

Mount the stop valve or the check valve (recommended by YOKOGAWA) through the nipple (found on the local market) at the calibration gas inlet of the equipment as illustrated in Figure 4.2. (The stop valve or the check valve may have been mounted on the equipment when shipped.)

Connect the ZA8F flow setting unit and the ZR202S analyzer to a 6 mm (O.D.) x 4 mm (I.D.) (or nominal size 1/4 inches) or larger stainless steel pipe.

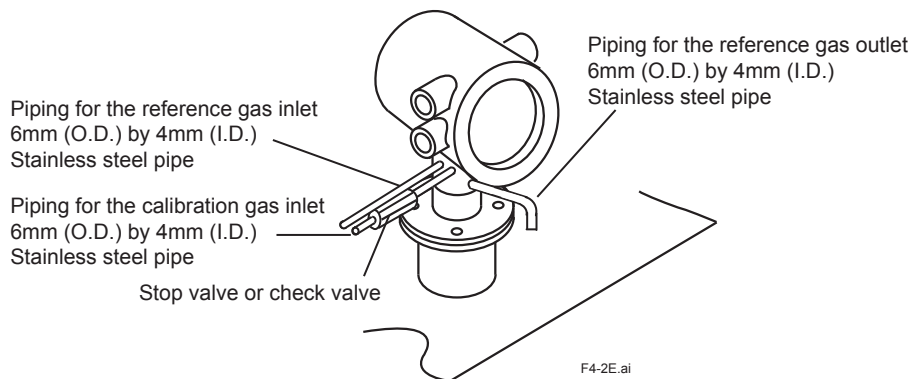

Figure 4.2 Piping for the Calibration Gas Inlet

4.1.3 Piping for the Reference Gas Inlet

Reference gas piping is required between the air source (instrument air) and the ZA8F flow setting unit, and between the flow setting unit and the ZR202S analyzer.

Insert the air set next to the flow setting unit in the piping between the air source and the flow setting unit.

Use a 6 mm (O.D.) x 4 mm (I.D.) (or nominal size 1/4 inch) stainless steel pipe between the flow setting unit and the analyzer.

4.1.4 Piping for the Reference Gas Outlet

If the ZR202S is exposed to rain or water splash, connect the pipe outlet on downward.

4.2 Piping for System 2

Piping in System 2 is illustrated in Figure 4.3. In System 2, calibration is automated; however, the piping is basically the same as that of System 1. Refer to Section 4.1.

Adjust secondary pressure of both the air set and the zero gas pressure reducing valve so that these two pressures are approximately the same. The flow rate of zero and span gases (normally instrument air) are set by a individual needle valve. After installation and wiring, check the calibration contact output (see Sec. 7.9.2), and adjust zero gas pressure reducing valve and calibration gas needle valve so that zero gas flow is within the permitted range. Next check span gas calibration contact output and adjust air set so that span gas flow is within the permitted range.

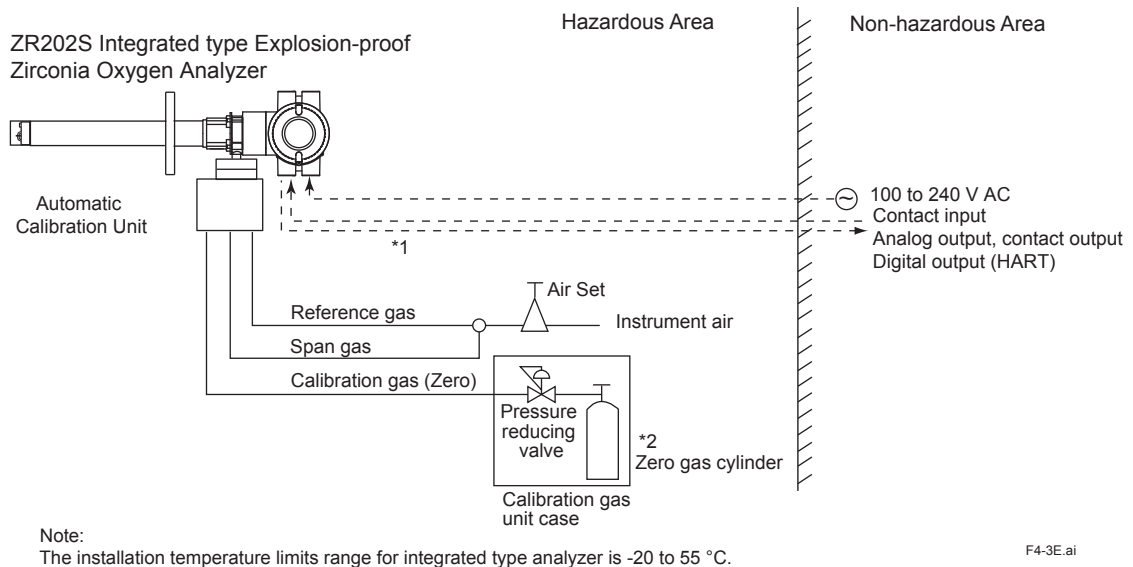
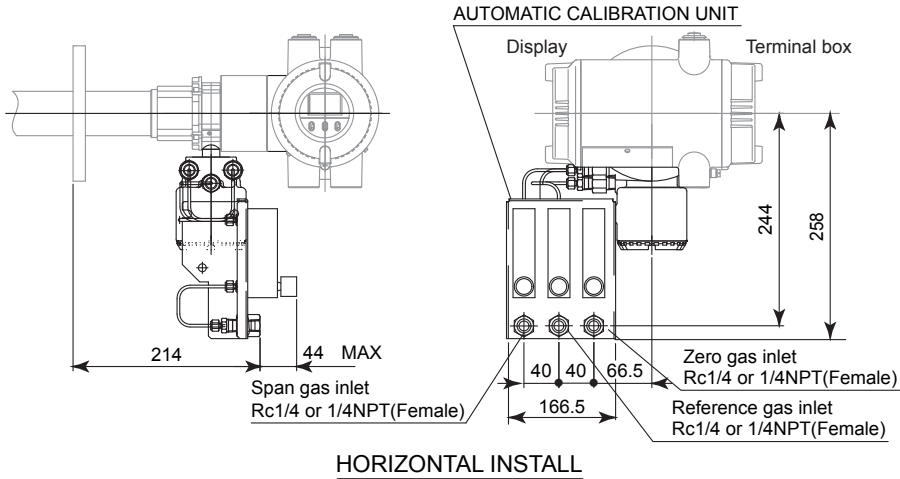

Figure 4.3 Piping for System 2

• Installation of Automatic Calibration Unit

Horizontal mounting on the ZR202S (-A)

Unit: mm



Vertical mounting on the ZR202S (-B)

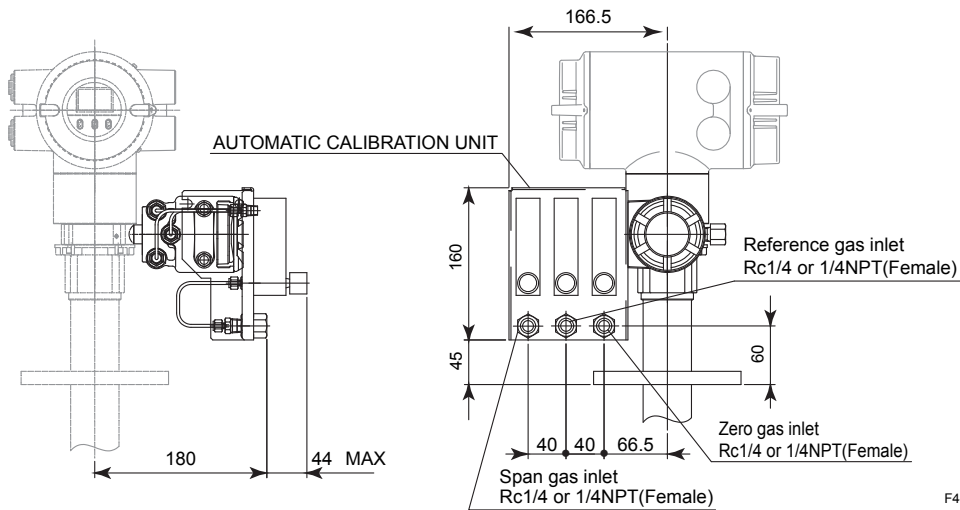

F4-4E.ai

Piping Diagram

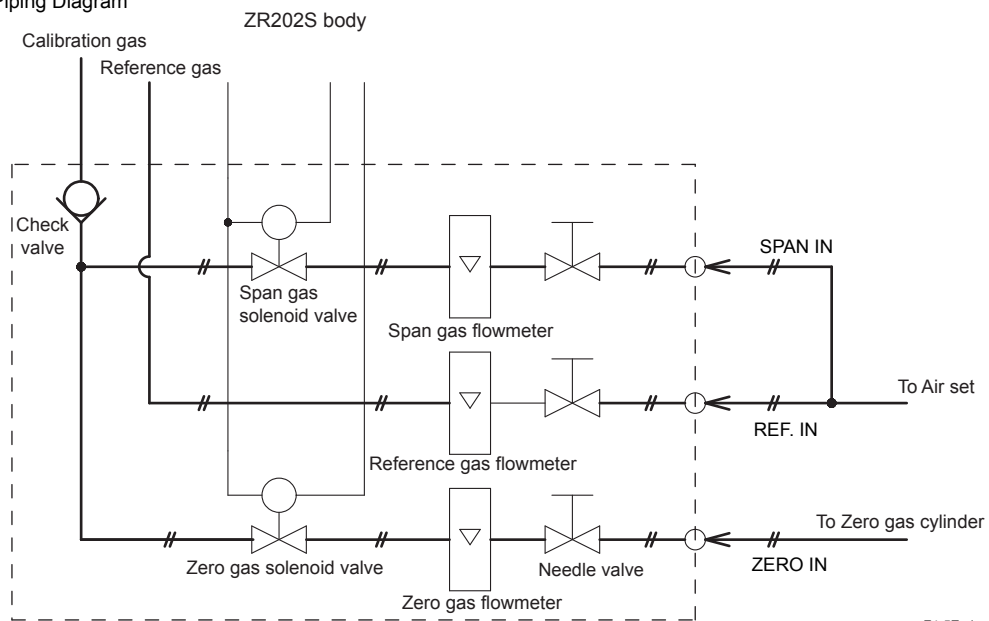

F4-5E.ai

5. Wiring

This chapter describes wiring procedures necessary for the EXAxt ZR Integrated type Explosion-proof Zirconia Oxygen Analyzer.

5.1 General

CAUTION

Be sure to read Subsections 3.1.2 to 3.1.5 where the important information on wiring is provided.

CAUTION

- Never supply current to the equipment or any other device constituting a power circuit in combination with the equipment, until all wiring is completed.
- This product complies with CE marking.
Where a performance suit for CE marking is necessary, the following wiring procedure is necessary.
 1. Install an external switch or circuit breaker to the power supply of the equipment.
 2. Use an external switch or circuit breaker rated 5 A and conforms to IEC 947-1 or IEC 947-3.
 3. It is recommended that the external switch or circuit breaker be mounted in the same room as the equipment.
 4. The external switch or circuit breaker should be installed within the reach of the operator, and marked as the power supply switch of this equipment.

Wiring procedure

Wiring should be made according to the following procedure:

1. Be sure to connect the shield of the shielded line to FG terminal of the analyzer.
2. The most outer sheath of the signal line and the power cable should be stripped off to the minimum necessary length.
3. Signal will be affected by noise emission when the signal lines, power cable and heater cable are located in the same conduit. When using a conduit, signal lines should be installed in the separate conduit from power and heater cables. Be sure to ground the metal conduit.
4. Mount the attached two blind plugs to unused cable connection gland(s) of the equipment.
5. The cables indicated in Table 5.1 are used for wiring.
6. After completing the wiring, screw the cover in the terminal box body and secure it with a lock screw.

Table 5.1 Cable Specifications

Terminal name of analyzer	Name	Need for shields	Number of wires
L, N, \oplus	Power supply		2 or 3 *
AO+, AO-	Analog output	O	2
DO-1, DO-2	Contact output		2 to 8
DI-1, DI-2, DI-C	Contact input		3

Note *: When the case is used for protective grounding, use a 2-wire cable.

WARNING

Cables that withstand temperatures at least 80°C should be used for wiring.

NOTE

- Select an appropriate cable O.D. for the cable gland size.
- Protective grounding should have the grounding resistance of 100 Ω or less.

5.1.1 Terminals for the External Wiring

Remove the terminal cover on the opposite side of the display to gain access to the external wiring terminals.

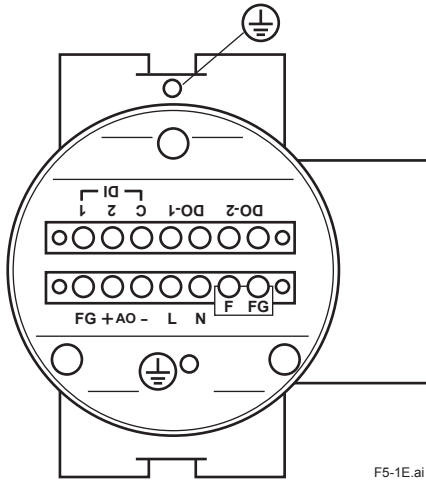
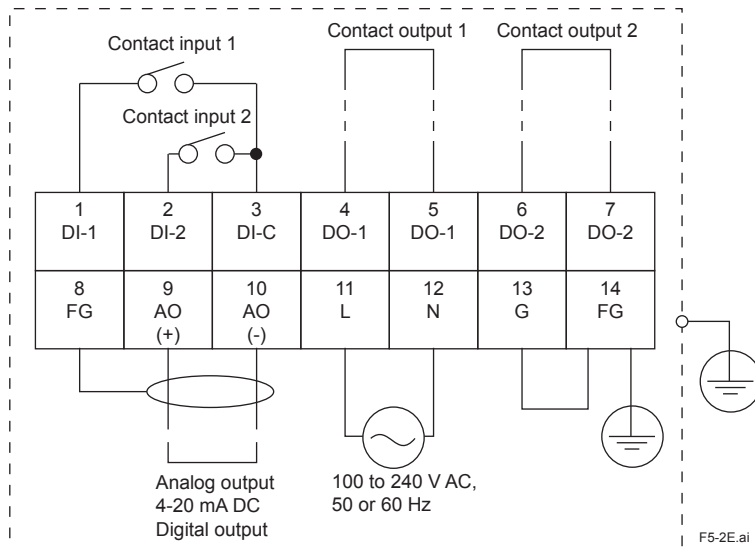

Figure 5.1 Terminals for External Wiring

5.1.2 Wiring

Make the following wiring for the equipment. It requires a maximum of four wiring connections as shown below.

- (1) Analog output signal
- (2) Power and ground
- (3) Contact output
- (4) Contact input



The protective grounding for the analyzer shall be connected either the protective ground terminal in the equipment or the ground terminal on the case. Standard regarding grounding: Ground to earth, ground resistance: 100 Ω or less.

Figure 5.2 Wiring Connection

5.1.3 Mounting of Cable Gland

For each wiring inlet connection of the equipment, mount the conduit appropriate for the screw size or a cable gland.

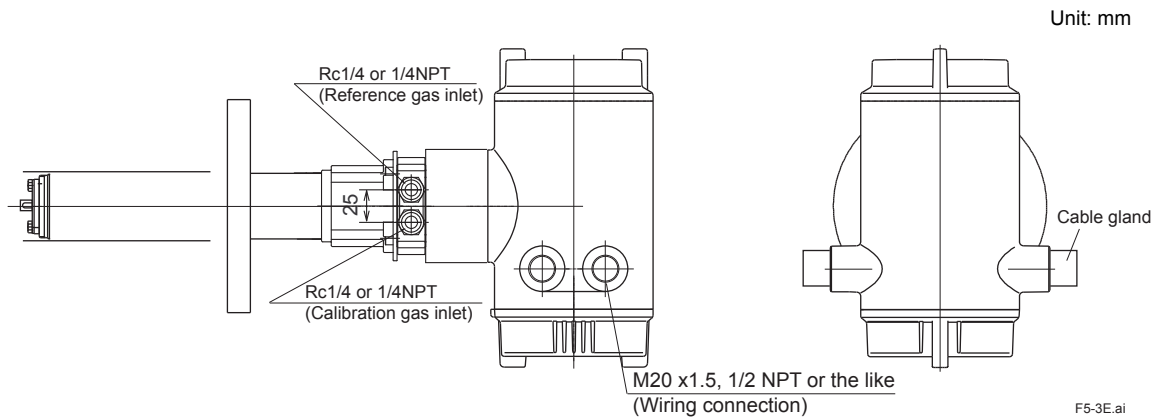

Figure 5.3 Cable Gland Mounting

5.2 Wiring for Analog Output

This wiring is for transmitting 4 to 20 mA DC output signals to a device, e.g. recorder. Maintain the load resistance including the wiring resistance of 550 Ω or less.

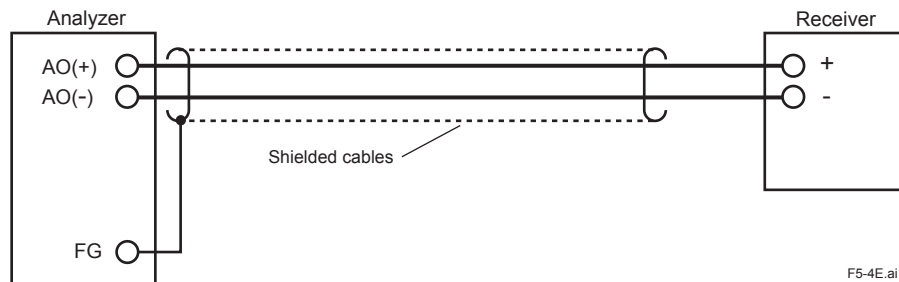

Figure 5.4 Wiring for Analog Output

5.2.1 Cable Specifications

Use a 2-core shielded cable for wiring.

5.2.2 Wiring Procedure

- (1) M4 screws are used for the terminals. Use crimp-on terminals appropriate for M4 terminal screws for cable connections. Ensure that the cable shield is connected to the FG terminal of the equipment.
- (2) Be sure to connect (+) and (-) polarities correctly.

CAUTION

- Before opening the cover, loosen the lock screw. If the screw is not loosened first, the cover will be improperly engaged to the body, and the terminal box will require replacement. When opening and closing the cover, remove any sand particles or dust to avoid gouging the thread.
- After screwing the cover on the equipment body, secure it with the lock screw.

5.3 Wiring Power and Ground Terminals

Wiring for supplying power to the analyzer and grounding the equipment.

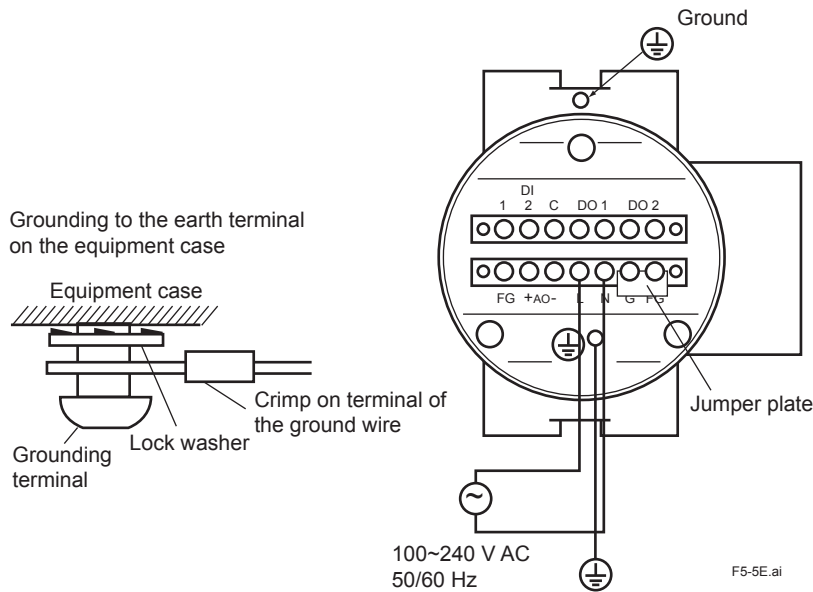

Figure 5.5 Power and Grounding Wiring

5.3.1 Wiring for Power Line

Connect the power wiring to the L and N terminals of the equipment. For a three-core cable, ground one core appropriately. Proceed as follows:

- (1) Use a two-core or a three-core cable.
- (2) M4 screws are used for the terminals. Use crimp-on terminals appropriate for M4 terminal screws for cable connections.

5.3.2 Wiring for Ground Terminals

The ground wiring of the analyzer should be connected to either the ground terminal of the equipment case (M5) or the terminal inside of the equipment (M4). Proceed as follows:

- (1) Keep the ground resistance of 100 Ω or less (JIS D style (Class 3) grounding).
- (2) When connecting the ground wiring to the ground terminal of the equipment case, be sure that the lock washer is in contact with the case surface (see Figure 5.5.).
- (3) Ensure that the jumper plate is connected between the G terminal and the FG terminal of the equipment.
- (4) The size of external ground screw thread is M5.
Each cable should be terminated corresponding crimp-on terminals.
- (5) No intermediate parts are used for the ground terminal inside of the equipment. Use crimping terminal for connection to the ground terminal inside of the equipment in order to avoid corrosion by high contact potentials.
- (6) In order to prevent the earthing conductor from loosening, the conductor must be secured to the terminal, tightening the screw with torque of approx. 1.2 N•m (for M4) or 2.0 N•m (for M5).
- (7) Care must be taken not to twist the conductor.

5.4 Wiring for Contact Output

The equipment can output a maximum of two contact signals. These contact outputs can be used for different applications such as a low alarm or high alarm.

Do the contact output wiring according to the following requirements.

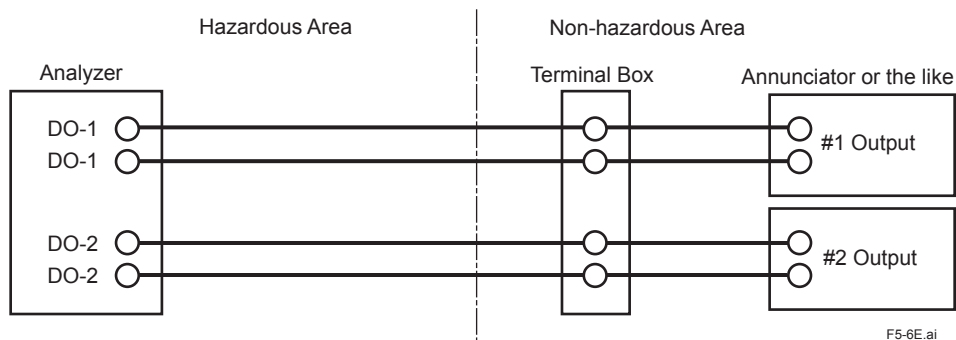

Figure 5.6 Contact Output Wiring

5.4.1 Cable Specifications

The number of cores varies depending on the number of contacts used.

5.4.2 Wiring Procedure

- (1) M4 screws are used for the terminals. Use crimp-on terminals appropriate for M4 terminal screws for cable connections.
- (2) The contact output relays are rated 30 V DC 3A, 250 V AC 3A. Connect a load (e.g. pilot lamp and annunciator) within these limits.

5.5 Wiring for Contact Input

The analyzer can execute specified function when receiving contact signals.

To use these contact signals, proceed wiring as follows:

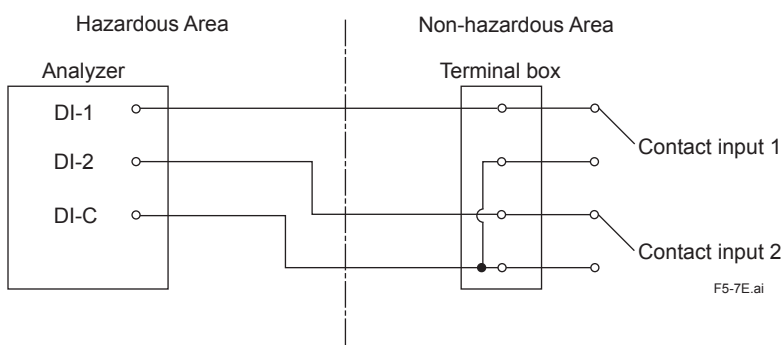

Figure 5.7 Contact Input Wiring

5.5.1 Cable Specifications

Use a 2-core or a 3-core cable for this wiring. Depending on the number of input(s), determine which cable to use.

5.5.2 Wiring Procedure

- (1) M4 screws are used for the terminal of the analyzer. Each cable should be equipped with the corresponding crimp contact.

- (2) The ON/OFF level of this contact input is identified by the resistance. Connect a contact input that satisfies the descriptions in Table 5.2.

Table 5.2 Identification of Contact Input ON/OFF

	Closed	Open
Resistance	200 Ω or less	100 k Ω or more

6. Components

This chapter describes the names and functions of components for the major equipment of the EXAxt ZR Integrated type Explosion-proof Zirconia Oxygen Analyzer.

6.1 ZR202S Zirconia Oxygen Analyzer

■ Integrated type Explosion-proof Zirconia Oxygen Analyzer

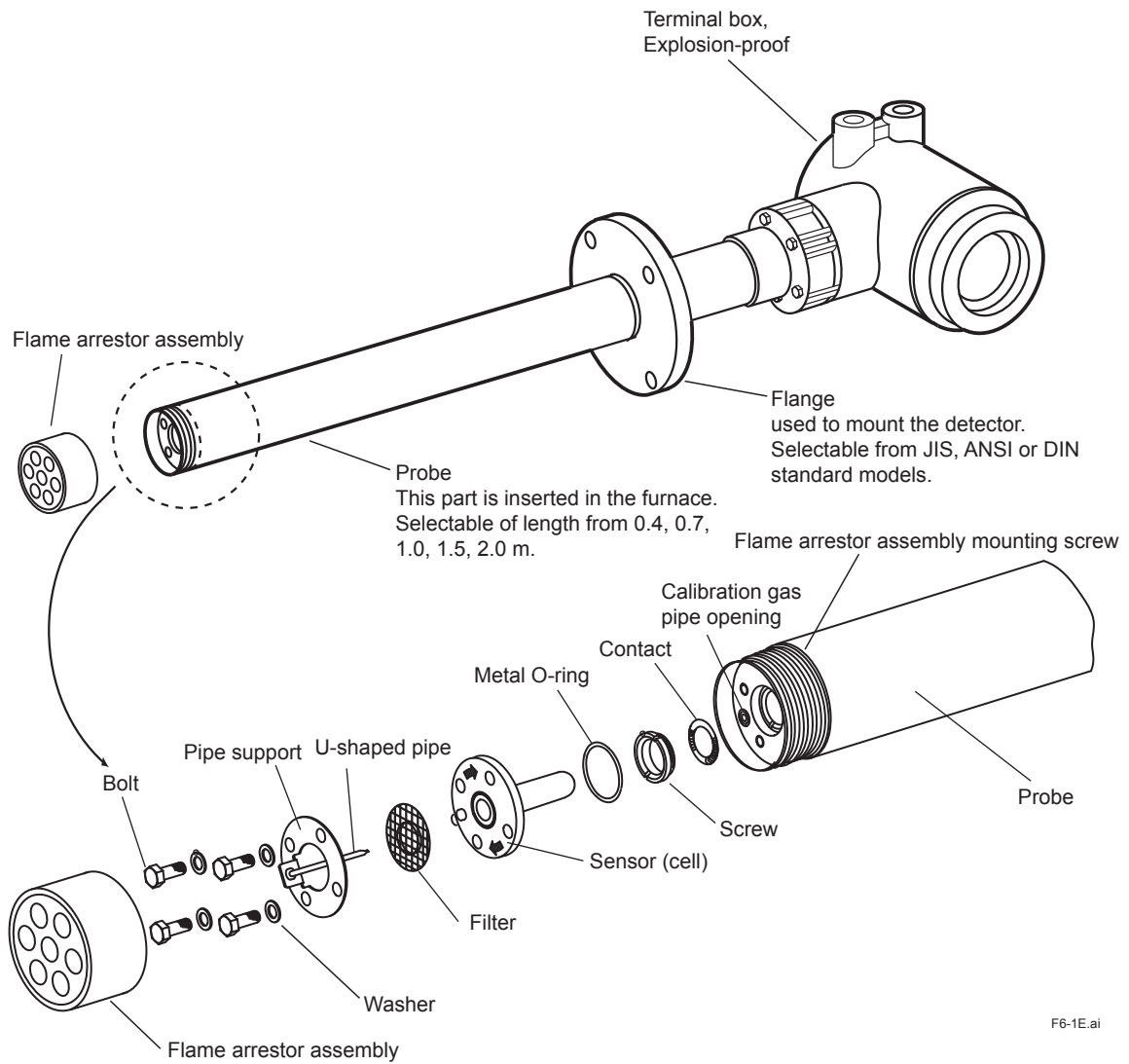

F6-1E.ai

Figure 6.1 Integrated type Explosion-proof Zirconia Oxygen Analyzer

6.2 ZA8F Flow Setting Unit, Automatic Calibration Unit

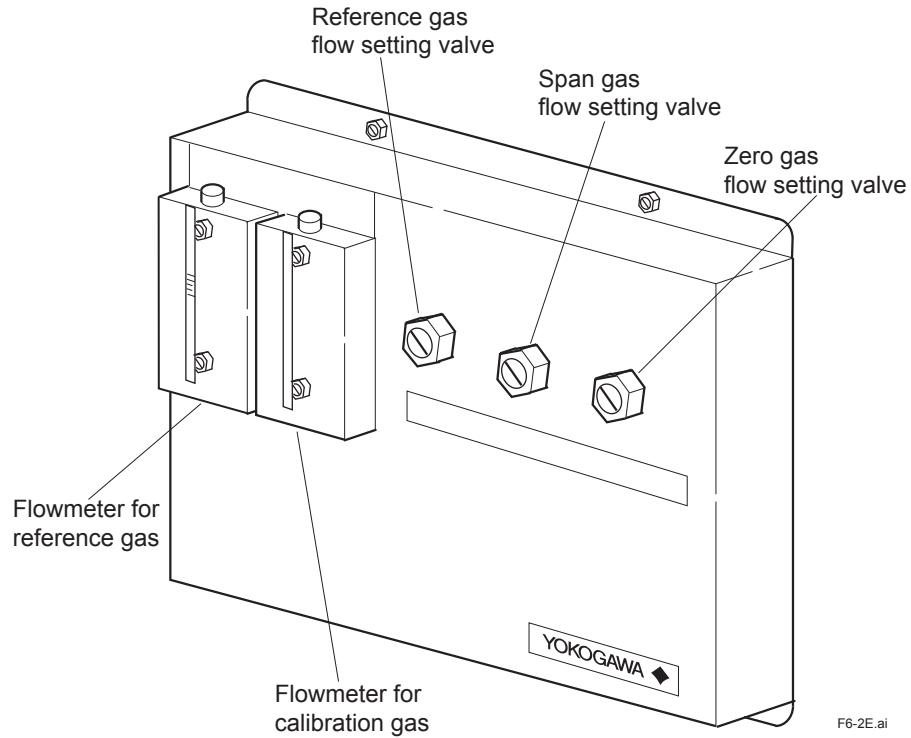

Figure 6.2 ZA8F Flow Setting Unit

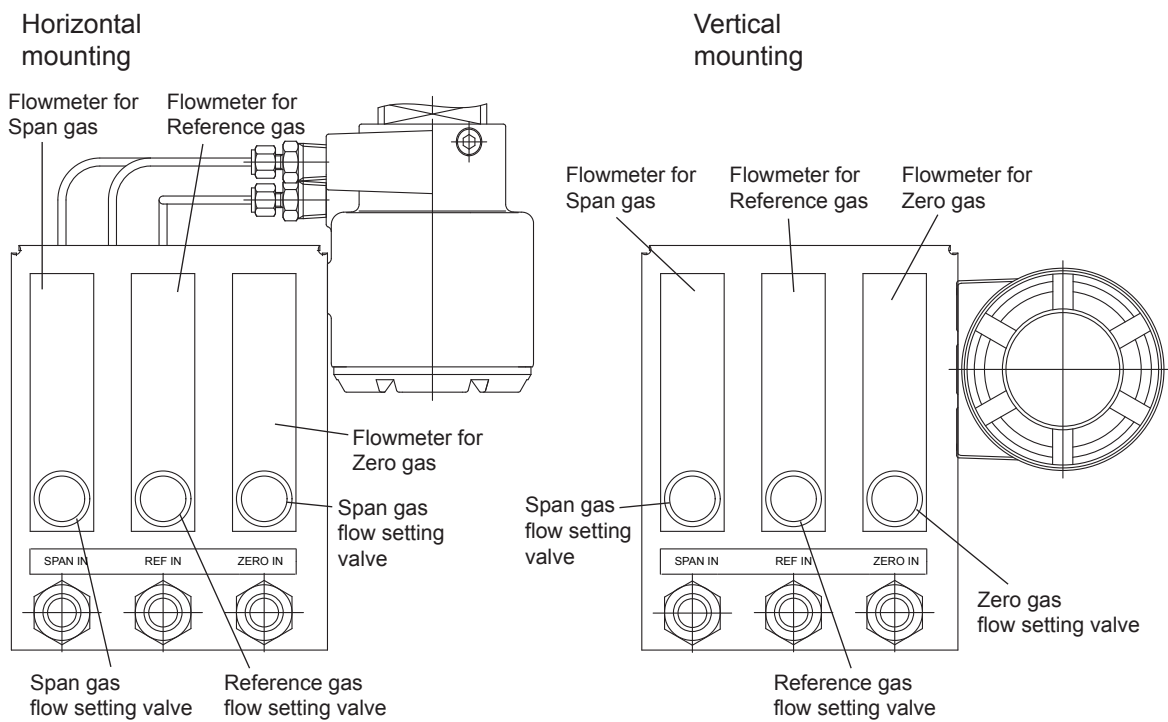

Figure 6.3 Automatic Calibration Unit

7. Startup

The following describes the minimum operating requirements — from supplying power to the analyzer to analog output confirmation to manual calibration.

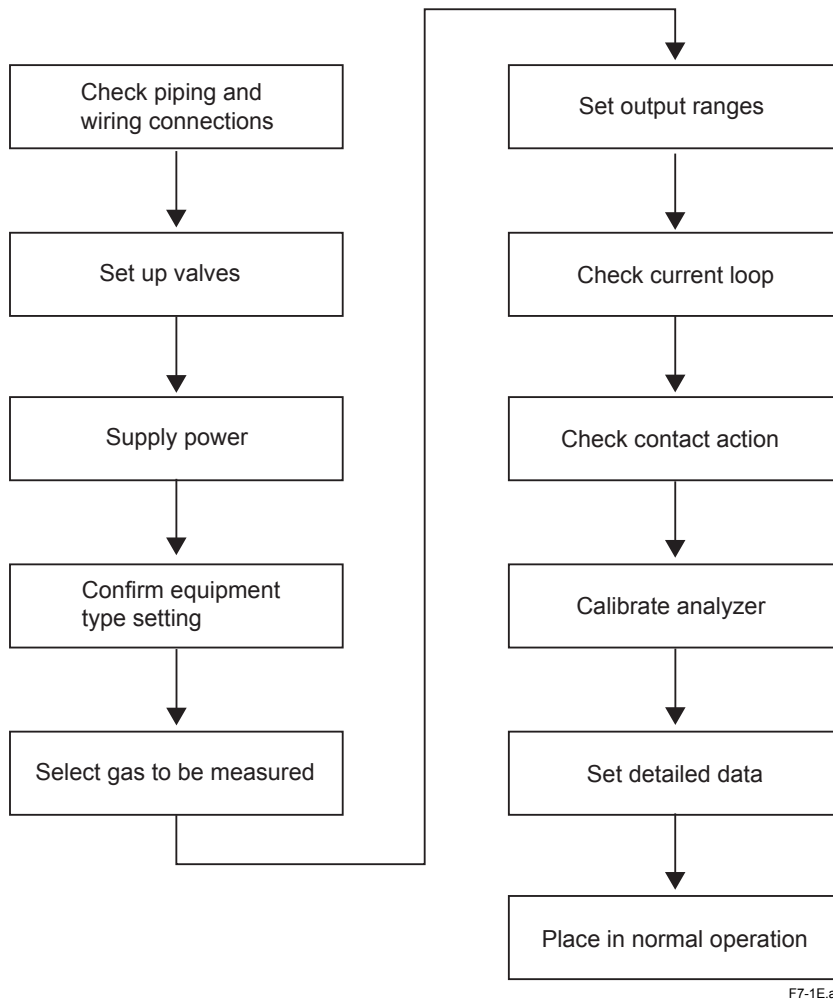

Figure 7.1 Startup Procedure

For system tuning by HART communication, refer to the IM 11M12A01-51E "HART Communication Protocol".

7.1 Checking Piping and Wiring Connections

Refer to Chapters 4 and 5, earlier in this manual, for piping and wiring confirmations.

7.2 Valve Setup

Set up valves and associated components used in the analyzer system in the following procedures:

- (1) If a stop valve is used in the calibration gas inlet, fully close this valve.
- (2) If instrument air is used as the reference gas, adjust the Air set secondary pressure so that the air pressure of sample gas pressure plus approx. 50 kPa (plus approx. 150 kPa for with check valve) (300 kPa maximum) is obtained. Turn the reference gas flow setting valve in the ZA8F flow setting unit to obtain the flow of 800 to 1000 mL/min. (Turning the valve shaft counterclockwise increases the rate of flow. When turning the valve shaft, if the valve has a lock nut, first loosen the lock nut.) After completing the valve setup, be sure to tighten the lock nut.

NOTE

The calibration gas flow setting will be described later. Fully close the needle valve in the flow setting unit.

7.3 Supplying Power to Analyzer

CAUTION

To avoid temperature changes around the sensor, it is recommended that the power be continuously supplied to the Oxygen Analyzer if it is used in an application where its operations and suspensions are periodically repeated.

It is also recommended to flow a span gas (instrument air) beforehand.

Supply power to the analyzer. A display as in Figure 7.2, which indicates the detector's sensor temperature, then appears. As the heat in the sensor increases, the temperature gradually rises to 750°C. This takes about 20 minutes after the power is turned on, depending somewhat on the ambient temperature and the sample gas temperature. After the sensor temperature has stabilized at 750°C, the analyzer is in the measurement mode. The display panel then displays the oxygen concentration as in Figure 7.3. This is called the basic panel display.



F7-2E.ai

Figure 7.2 Display of Sensor Temperature While Warming Up

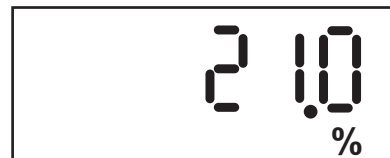

F7-3E.ai

Figure 7.3 Measurement Mode Display

7.4 Operation of Infrared Switch

7.4.1 Display and Switches

This equipment uses an infrared switch that enables operation with the cover closed. Figure 7.4 shows the infrared switch and the display. Table 7.1 shows the three switch (keys) and functions.

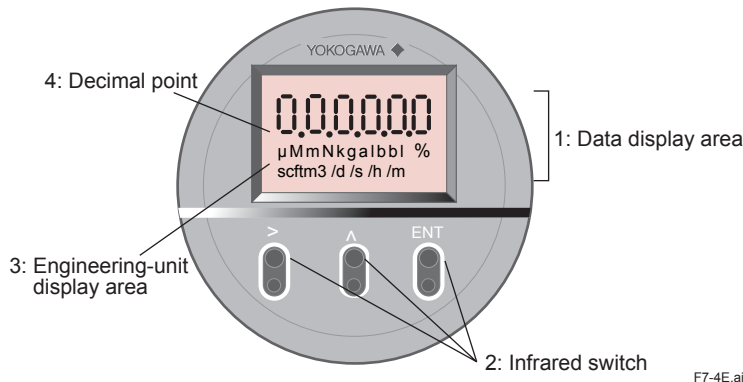

Figure 7.4 Infrared switch and the display

1. Data display area: Displays the oxygen concentration, set values, alarm numbers, and error numbers.
2. Infrared switch: Three switches perform data setting operations.
3. Engineering-unit display area: The percent sign appears when the oxygen concentration is displayed.
4. Decimal point: A decimal point is displayed.

Table 7.1 Switch and Function

Switch	Function
>	1. Moves the position of the digit to the right. If you continuously touch the key, the position of the digit will move continuously to the right, finally returning to the leftmost position after reaching the rightmost position of the digit. 2. Selects Yes or No. 3. When you touch this key together with the [ENT] key, the previous display then appears, or the operation will be cancelled.
^	Used to change values. If you continuously touch this key, the value of the digit will increase continuously, e.g., from 1 to 2 to 3 (for numeric data), or from A to B to C (for alphabetic characters), and finally return to its original value.
ENT	1. Used to change the basic panel display to the parameter selection display. 2. Used to enter data. 3. Advances the operation.

The three infrared switches are activated by completely touching the glass surface of the switch. To touch any of the keys continuously, first touch the surface and then completely remove your finger from the surface. Then touch it again.

Infrared switches consist of two elements: an infrared emitting element and an infrared acceptance element. Infrared light-waves from the element bounces on the operator's finger and are reflected back to the acceptance element, thereby causing the infrared switch to turn on and off, depending on the strength of the reflected light-waves. From this operating principles, carefully observe the following:

CAUTION

1. Be sure to put the equipment case cover back on. If this is not done, the infrared switch will not reflect the infrared light-waves, and a “dSPErr” error will be issued.
2. Before placing the equipment in operation, be sure to wipe off any moisture or dust on the glass surface if it is wet or dirty. Also make sure your fingers are clean and dry before touching the glass surface of the switch.
3. If the infrared switches are exposed to direct sunlight, they may not operate correctly. In such a case, change position of the display or install a sun cover.

7.4.2 Display Configuration

The parameter codes provided for the equipment are used to control the equipment display panels (see below). By selecting appropriate parameter codes, you can conduct calibration and set operation parameters. Figure 7.5 shows the configuration of display items. The parameter codes are listed in groups of seven; which are briefly described in Table 7.2.

To enter parameters, you first need to enter the password, refer to Subsection 7.4.3.

Touch the [>] key and [ENT] key at same time to revert to the main screen.

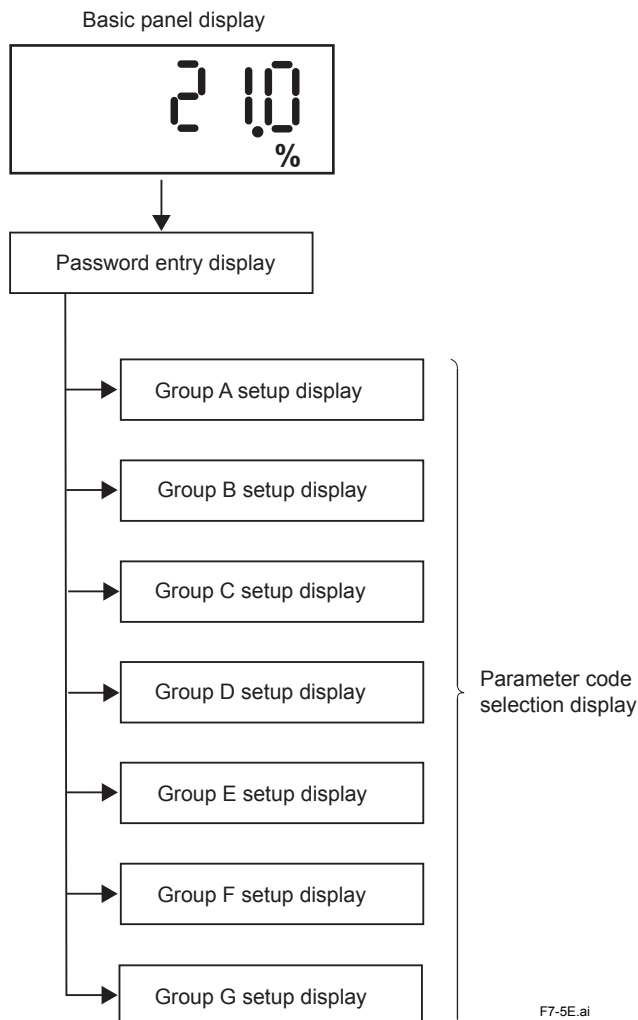

Figure 7.5 Display Configuration









Table 7.2 Display Functions

Display	Function and item to be set
Basic panel	Displays the oxygen concentration in normal operation, or displays the detector heater temperature while warming up. If an error or alarm arises, the corresponding error or alarm number appears.
Password entry	Enters the password for the parameter code selection display.
Group A setup	Displays detailed data, such as the cell voltage or temperature.
Group B setup	Sets and performs calibration.
Group C setup	Sets analog output.
Group D setup	Sets an alarm.
Group E setup	Sets the contact inputs and contact outputs.
Group F setup	Selects the type of equipment and sets the parameters for computation.
Group G setup	Performs the current-loop or contact checks.

7.4.3 Entering Parameter Code Selection Display

This subsection briefly describes the password entry procedure for entering the parameter code selection display. The password is 1102 - it cannot be changed to a different password.

Table 7.3 Parameter Code Selection

Switch operation	Display	Description
> ^ ENT	21.0%	Warm-up is complete, and the basic panel is now displayed.
> ^ ENT 	PASSno	Continuously touch the [ENT] key for at least three seconds to display "PASSno".
> ^ ENT 	0000	Touch the [ENT] key again. This allows you to change the leftmost digit that is flashing.
> ^ ENT 	1000	Set the password 1102. If you touch the [^] key, the digit that is flashing will be 1.
> ^ ENT 	1000	Touch the [>] key to move the position of the digit that is flashing to the right one digit.
> ^ ENT 	1100	Touch the [^] key to change the numeric value to 1.
> ^ ENT 	1100	Touch the [>] key again to move the position of the digit that is flashing to the right one more digit. Continuously touch the [>] key, and the position of the digit that is flashing will move continuously to the right.
> ^ ENT 	1102	Touch the [^] key to change the numeric value to 2. Continuously touch [^] key, and the numeric value increases continuously.
> ^ ENT 	1102	If you touch the [ENT] key, all the digits flash.
> ^ ENT 	A01	Touch the [ENT] key again to display A01 on the parameter code selection display.







The symbol [] indicates that the key is being touched. Light characters indicate that the digits are flashing.

CAUTION

- If no key is touched for at least 20 seconds during password entry, the current display will automatically switch to the basic panel display.
- If no key is touched for at least 10 minutes during parameter code selection, the current display will automatically switch to the basic panel display.

7.4.4 Selecting Parameter Codes





Table 7.4 Parameter Code

Switch operation			Display	Description
>	^	ENT	A01	Password has been entered and the parameter code selection display has appeared. Character A is flashing, indicating that character A can be changed.
	^	ENT	A01	If you touch the [>] key once, the position of the digit that is flashing will move to the right. This allows you to change 0.
	^	ENT	A01	Touch the [>] key again to move the position of the digit that is flashing to the right one more digit. This enables you to change numeric value to 1.
	^	ENT	A01	Touch the [>] key again to return the position of the digit that is flashing to A. Continuously touch the [>] key, and the position of the digit that is flashing will move continuously to the right.
>		ENT	b01	If you touch the [^] key once, character A will change to b.
>		ENT	C01	Touch the [^] key once to change to C.
>		ENT	d01	Continuously touch the [^] key, and the value of the digit that is flashing will increase continuously, from d to E to F to G to A. Numeric values will change from 0 to 1 to 2 to 3 ... to 8 to 9 and back to 0. However, numbers that are not present in the parameter codes will be skipped. Each digit is changed independently. Even though a low-order digit changes from 9 to 0, a high-order digit will not be carried.
>	^		Set Value	After you select the desired character, touch the [ENT] key. The set data will be displayed.







The symbol [] indicates that the key is being touched. Light characters indicates that the digits are flashing.

7.4.5 Changing Set Values



(1) Selecting numeric values from among preset values

Switch operation			Display	Description
>	^	ENT	0	The set value is displayed after the parameter code selection. An example of how to select either 0, 1, or 2 as the set value is given below. (The currently set value is 0.)
>	^ 	ENT	1	Touch the [^] key once to change the current value from 0 to 1.
>	^ 	ENT	2	Touch the [^] key again to change to the numeric value to 2.
>	^ 	ENT	0	If you touch the [^] key again, the numeric value will return to 0. Continuously touch the [^] key, and the numeric values will change continuously.
>	^ 	ENT	C01	Display the desired numeric value and touch the [ENT] key. The display will then return to the parameter code selection

(2) Entering numeric values such as oxygen concentration values and factors

Switch operation			Display	Description
>	^	ENT	00.0	The set value is displayed after the parameter code selection. An example of entering "9.8" is given below. (The currently set value is 0.0)
> 	^	ENT	00.0	Touch the [>] key to move the position of the digit that is flashing to the digit to be changed. Continuously touch the [>] key, and the position of the digit that is flashing will move continuously to the right.
>	^ 	ENT	09.0	Touch the [^] key to set the numeric value to 9. Continuously touch the [^] key, and the numeric value will change in sequence from 0 to 1 to 2 to 3 ... to 8 to 9 and back to 0.
> 	^	ENT	09.0	Touch the [>] key to move the position of the digit that is flashing to the right.
>	^ 	ENT	09.8	Touch the [^] key to set the numeric value to 8.
>	^ 	ENT	09.8	Where the correct numeric value is displayed, touch the [ENT] key.
>	^ 	ENT	09.8	If you touch the [ENT] key again, the flashing stops and the current set value will be in effect.
>	^ 	ENT	C11	Touch the [ENT] key once again to return to the parameter code selection display.

(3) If invalid numeric values are entered.

Switch operation			Display	Description
>	^ 	ENT	98.0	If an invalid numeric value (beyond the input range specified) is entered, "Err" will appear for two seconds after touching the [ENT] key.
>	^ 	ENT	Err	
>	^	ENT	00.0	"Err" appears for two seconds, and the display returns to the first set value. Re-enter the numeric value.

7.5 Confirmation of Equipment Type Setting

This equipment can be used for both the Oxygen Analyzer and the Humidity Analyzer. If you choose optional specification /HS at the time of purchase, the equipment is set for the Humidity Analyzer.









Before setting the operating data, be sure to check that the desired model has been set.

Note that if the equipment type setting is changed after operating data are set, the operating data that have been set are then initialized and the default settings remain. Set the equipment type with parameter code [F01]. See Table 10.7, later in this manual.

CAUTION

Note that if the equipment type is changed, operation data that have already been set are initialized (reverting to the default setting).

Table 7.5 Equipment Type Setting Procedure











Switch operation			Display	Description
>	^	ENT	A01	Display after the password has been entered.
>		ENT	F01	Touch the [^] key to switch to Group F. If an unwanted alphabetic character after F has been entered, continuously touch the [^] key to return to the original.
>	^		0	Touch the [ENT] key for confirmation. If 0 (zero) is entered, the oxygen analyzer is already set. If 1 (one) is entered, the humidity analyzer has been set. Change the setting following the steps below.
>		ENT	0	Continuously touch the [^] key, and the position of the digit will change from 1 to 0 to 1 to 0. Release the [ENT] key when 0 is displayed.
>	^		0	Touch the [ENT] key. The numeric value will flash.
>	^		0	Touch the [ENT] key again to stop the numeric value from flashing.
>	^		F01	Touch the [ENT] key once again, and the display will change to the parameter code.
	^		Basic panel display	Touch the [>] key together with the [ENT] key to return to the basic panel display. (This is not required if you proceed to make another setting.) (The displayed numeric values indicate the measurement gas concentration.)

The symbol [] indicates that the key is being touched. Light characters indicates that the digits are flashing.

7.6 Selection of Measurement Gas

Combustion gases contain moisture created by burning hydrogen in the fuel. If this moisture is removed, the oxygen concentration might be higher than before. You can select whether the oxygen concentration in a wet gas is to be measured directly, or compensated for its dry-gas value before use. Use the parameter code [F02] to set the measurement gas. For details on the parameter code, see Table 10.7, later in this manual.

Table 7.6 Setting Measurement Gas

Switch operation			Display	Description
>	^	ENT	A01	Display after the password has been entered.
>		ENT	F01	Touch the [^] key to switch to Group F. If an unwanted alphabetic character after F has been entered, continuously touch the [^] key to return to the original.
	^	ENT	F01	Touch the [>] key to move the position of the digit that is flashing to the right.
>		ENT	F02	Touch the [^] key to change the numeric value to 2. If an unwanted numeric value has been entered, continuously touch the [^] key to return to the original.
>	^		0	Touch the [ENT] key for confirmation. If 0 (zero) is entered, the oxygen concentration in a wet gas is already set. If the oxygen concentration in a dry gas is to be entered, follow the steps below to set 1 (one).
>		ENT	1	Continuously touch the [^] key, and the position of the digit will change from 1 to 0 to 1 to 0. Release the [ENT] key when 1 (one) is displayed.
>	^		1	Touch the [ENT] key. The numeric value will flash.
>	^		1	Touch the [ENT] key again to stop the value from flashing.
>	^		F03	Touch the [ENT] key once again, and the display will change to the parameter code selection panel.
	^		Basic panel display	Touch the [>] key together with the [ENT] key to return to the basic panel display. (This is not required if you proceed to make another setting.) (The displayed numeric values indicate the measurement gas concentration.)

The symbol [] indicates that the key is being touched. Light characters indicates that the digits are flashing.



















7.7 Output Range Setting

This section sets forth analog output range settings. For details, consult Section 8.2, “Current Output Setting”, later in this manual.

■ Minimum Current (4 mA) and Maximum Current (20 mA) Settings

Use the parameter codes [C11] to set the oxygen concentration at 4 mA and [C12] to set the oxygen concentration at 20 mA. The following shows where 10%O₂ is set at 4 mA and 20%O₂ at 20 mA.

Table 7.7 Minimum and Maximum Current Setting Procedure









Switch operation			Display	Description
>	^	ENT	A01	Display after the password has been entered.
>		ENT	C01	Set the oxygen concentration at 4 mA. Change the parameter code to C11. Touch the [^] key to switch to Group C.
	^	ENT	C01	Touch the [>] key to move the position of the digit that is flashing to the right.
>		ENT	C11	Touch the [^] key to enter the numeric value to 1.
>	^		000	Touch the [ENT] key to display the current set value (0% O ₂ has been set).
	^	ENT	000	Touch the [>] key to move the position of the digit that is flashing to the right.
>		ENT	010	Touch the [^] key to change the numeric value to 1.
>	^		010	If you touch the [ENT] key, all the digits flash.
>	^		010	Touch the [ENT] key again to stop the flashing.
>	^		C11	Touch the [ENT] key once again, and the display will switch to the parameter code selection display.
	^	ENT	C11	Set the oxygen concentration at 20 mA. Touch the [>] key to move the position of the digit that is flashing to the right.
>		ENT	C12	Touch the [^] key to enter the numeric value to 2.
>	^		025	Touch the [ENT] key to display the current set value.
	^	ENT	025	Touch the [>] key to move the position of the digit that is flashing to the right.
>		ENT	020	Touch the [^] key to change the numeric value to 0. The numeric value will change from 5 to 6 ... to 9 and back to 0.
>	^		020	If you touch the [ENT] key, all the digits flash.
>	^		020	Touch the [ENT] key again to stop the flashing.
>	^		C12	Touch the [ENT] key once again to switch to the parameter code selection display.
	^		Basic panel display	Touch the [>] key together with the [ENT] key to return to the basic panel display. (This is not required if you proceed to make another setting.)(The displayed numeric values indicate the measurement gas concentration.)

The symbol [] indicates that the key is being touched. Light characters indicate that the digits are flashing.

7.8 Checking Current Loop

The set current can be output as an analog output. This enables the checking of wiring between the analyzer and the receiving instrument. Current loop checking is performed using parameter code [G01].

Table 7.8 Checking Current Loop

Switch operation			Display	Description
>	^	ENT	A01	Display after the password has been entered.
>	 ^	ENT	G01	Touch the [^] key to switch to Group G.
>	^	 ENT	00.0	Touch the [ENT] key. The current output remains preset with the output-hold feature (Section 2.3).
>	 ^	ENT	10.0	Touch the [^] key to set the numeric value to 1 (to set a 10-mA output).
>	^	 ENT	10.0	Touch the [ENT] key to have all the digits flash.
>	^	 ENT	10.0	Touch the [ENT] key again to stop the flashing. A 10-mA output is then issued.
>	^	 ENT	G01	Touch the [ENT] key once again to switch to the parameter code selection display. At that point, the current output returns to the normal value.
 >	^	 ENT	Basic panel display	Touch the [>] key together with the [ENT] key to return to the basic panel display.

The symbol [] indicates that the key is being touched. Light characters indicates that the digits are flashing.

7.9 Checking Contact I/O

Conduct a contact input and output check as well as an operation check of the solenoid valves for the optional automatic calibration unit.











Table 7.9 Parameter Codes for Checking Contact I/O

Check item	Parameter code	Set value and contact action	
		Set value	Contact action
Contact output 1	G11	0	Open
		1	Closed
Contact output 2	G12	0	Open
		1	Closed
Automatic calibration solenoid valve (zero gas)	G15	0	Off
		1	On
Automatic calibration solenoid valve (span gas)	G16	0	Off
		1	On
Contact input 1	G21	0	Open
		1	Closed
Contact input 2	G22	0	Open
		1	Closed

7.9.1 Checking Contact Output

Follow Table 7.10 to check the contact output. The table uses an example with contact output 1.

Table 7.10 Checking Contact Output

Switch operation			Display	Description
>	^	ENT	A01	Display after the password has been entered.
>		ENT	G01	Touch the [^] key to switch to Group G.
	^	ENT	G01	Touch the [>] key to move the position of the digit that is flashing to the right one digit.
>		ENT	G11	Touch the [^] key to enter 1.
>	^		0	Touch the [ENT] key to have 0 (zero) flash. The contact output is then open.
>		ENT	1	Touch the [^] key to set 1 (one).
>	^		1	Touch the [ENT] key. The flashing continues.
>	^		1	Touch the [ENT] key again to stop the flashing, and the contact output will be closed.
>	^		G11	Touch the [ENT] key once again to switch to the parameter code selection display. The contact output then returns to the original state.
	^		Basic panel display	Touch the [>] key together with the [ENT] key to return to the basic panel display. (This is not required if you proceed to make another setting.) (The displayed numeric values indicate the measurement gas concentration.)

The symbol [] indicates that the key is being touched. Light characters indicates that the digits are flashing.

CAUTION













If you conduct an open-close check for the contact output 2, Err-01 (cell voltage failure) or Err-02 (heater temperature abnormal) will occur. This is because the built-in heater power of the detector, which is connected to contact output 2, is turned off during the above check. So, if the above error occurs, reset the equipment or turn the power off and then back on to restart (refer to Section 10.4, "Reset", later in this manual).

7.9.2 Checking Calibration Contact Output

The calibration contacts are used for the solenoid valve drive signals for the Automatic Calibration Unit. This output signal enables you to check the equipment operation. Check the flowmeter gas flow for that operation.

Follow the steps in Table 7.11. The table uses an example with a zero gas solenoid valve.

Table 7.11 Checking Calibration Contact Output







Switch operation			Display	Description
>	^	ENT	A01	Display after the password has been entered.
>		ENT	G01	Touch the [^] key to switch to Group G.
	^	ENT	G01	Touch the [>] key to move the position of the digit that is flashing to the right one digit.
>		ENT	G11	Touch the [^] key to enter 1.
	^	ENT	G11	Touch the [>] key to move the position of the digit that is flashing to the right one digit.
>		ENT	G15	Touch the [^] key to enter 5.
>	^		0	Touch the [ENT] key to have 0 flash. The solenoid valve remains closed.
>		ENT	1	Touch the [^] key to enter 1.
>	^		1	Touch the [ENT] key. The flashing continues.
>	^		1	Touch the [ENT] key again to stop the flashing, and the solenoid valve will be open to let the calibration gas flow.
>	^		G15	Touch the [ENT] key once again to switch to the parameter code selection display. The solenoid valve will then be closed.
	^		Basic panel display	Touch the [>] key together with the [ENT] key to return to the basic panel display. (This is not required if you proceed to make another setting.) (The displayed numeric values indicate the measurement gas concentration.)

The symbol [] indicates that the key is being touched. Light characters indicates that the digits are flashing.

7.9.3 Checking Contact Input

Follow Table 7.12 to check the contact input. The table uses an example with contact input 1.

Table 7.12 **Checking Contact Input**

Switch operation			Display	Description
>	^	ENT	A01	Display after the password has been entered.
>		ENT	G01	Touch the [^] key to switch to Group G.
	^	ENT	G01	Touch the [>] key to move the position of the digit that is flashing to the right one digit.
>		ENT	G21	Touch the [^] key to enter 2.
>	^		0	Touch the [ENT] key. 0 is displayed with the contact input open. If the contact input is closed, the display will be 1 (one). This enables you to check whether or not the wiring connections have been properly made or not.
>	^		G21	Touch the [ENT] key once again to switch the parameter code selection display.
	^		Basic panel display	Touch the [>] key together with the [ENT] key to return to the basic panel display.

The symbol [] indicates that the key is being touched. Light characters indicates that the digits are flashing.

7.10 Calibration

The analyzer is calibrated in such a way that the actual zero and span gases are measured and those measured values are used to agree with the oxygen concentrations in the respective gases.

There are three types of calibration procedures available:

- (1) Manual calibration conducting zero and span calibrations, or either of these calibrations in turn.
- (2) Semi-automatic calibration which uses the infrared switches or a contact input signal and conducts calibration operations based on a preset calibration time and stable time.
- (3) Automatic calibration conducted at preset intervals.

Manual calibration needs the ZA8F Flow Setting Unit to allow manual supply of the calibration gases. Semi-automatic and automatic calibrations need Automatic Calibration Unit to allow automatic supply of the calibration gases. The following sections set forth the manual calibration procedures. For details on semi-automatic and automatic calibrations, consult Chapter 9, "Calibration" later in this manual.

7.10.1 Calibration Setup

Set the following three items before carrying out a calibration. Parameter codes for these set items are listed in Table 7.13.

- (1) Mode setting
There are three calibration modes: manual, semi-automatic, and automatic. Select the desired mode. This section uses manual mode for calibration.
- (2) Oxygen concentration in zero gas
Enter the zero gas oxygen concentration for calibration.
- (3) Oxygen concentration in span gas
Enter the span gas oxygen concentration for calibration. If instrument air is used, enter 21 vol% O₂. When using the ZO21S Standard Gas Unit (for use of the atmospheric air as a span gas), use a hand-held oxygen analyzer to measure the actual oxygen concentration, and then enter it.

CAUTION



















If instrument air is used for the span gas, dehumidify the air to a dew point of -20°C and remove any oil mist or dust.

Incomplete dehumidifying or unclean air will have an adverse effect on the measurement accuracy.

Table 7.13 Calibration Parameter Codes

Set item	Parameter code	Set value	
Calibration mode	B03	0	Manual calibration
		1	Semi-automatic, Manual calibration
		2	Automatic, Semi-automatic, Manual calibration
Zero gas oxygen concentration	B01	Enter oxygen concentration.	
Span gas oxygen concentration	B02	Enter oxygen concentration.	

Table 7.14 Calibration Setup Procedure

Switch operation			Display	Description
>	^	ENT	A01	Display after the password has been entered.
>	^ 	ENT	b01	Set the zero gas concentration. Switch the parameter code to B01. Here, set 0.98%.
>	^	ENT 	001.00 %	Touch the [ENT] key to display the currently set value.
> 	^	ENT	001.00 %	Touch the [>] key to move the position of the digit that is flashing to 1.
>	^ 	ENT	000.00 %	Touch the [^] key to change to 0.
> 	^	ENT	000.00 %	Touch the [>] key to move the position of the digit that is flashing to the right one digit.
>	^ 	ENT	000.90 %	Touch the [^] key to change the numeric value to 9.
> 	^	ENT	000.90 %	Touch the [>] key to move the position of the digit that is flashing to the right one digit.
>	^ 	ENT	000.98 %	Touch the [^] key to change the numeric value to 8.
>	^	ENT 	000.98 %	Touch the [ENT] key to have all the digits flash.
>	^	ENT 	000.98 %	Touch the [ENT] key again to stop the flashing.
>	^	ENT 	b01	Touch the [ENT] key once again to switch to the parameter code selection display.
Set the span gas concentration by above procedure, set 21%.				
>	^ 	ENT	b03	Next, set the calibration mode. Switch the parameter code to B03.
>	^	ENT 	0	Touch the [ENT] key to display the currently set value. If it is 0 (manual calibration), you can leave it as is. If it is other than 0, change it to 0 (zero).
>	^	ENT 	0	Touch the [ENT] key. The numeric value will flash.
>	^	ENT 	0	Touch the [ENT] key again to stop the flashing.
>	^	ENT 	b03	Touch the [ENT] key once again to switch to the parameter code selection display.
> 	^	ENT 	Basic panel display	Touch the [>] key together with the [ENT] key to return to the basic panel display. (This is not required if you proceed to make another setting.) (The displayed numeric values indicate the measurement gas concentration.)

The symbol [] indicates that the key is being touched. Light characters indicates that the digits are flashing.

7.10.2 Manual Calibration

The following describes how to conduct a calibration.







Preliminary

Before conducting a manual calibration, be sure that the ZA8F Flow Setting Unit zero gas flow valve is fully closed. Open the zero gas cylinder pressure reducing valve so that the secondary pressure will be a sample gas plus approx. 50 kPa (or sample gas pressure plus approx. 150 kPa when a check valve is used, maximum pressure rating is 300 kPa).









Calibration Implementation

This manual assumes that the instrument air is the same as the reference gas used for the span gas. Follow the steps below to conduct manual calibration. When using the ZO21S Standard Gas Unit (for use of the atmospheric air as a span gas), use a hand-held oxygen analyzer to measure the actual oxygen concentration, and then enter it.

Table 7.15 Conducting Calibration

Switch operation			Display	Description
>	^	ENT	A01	Display after the password has been entered.
>		ENT	b10	Switch the parameter code to B10. (The key operations for this procedure are omitted.)
>	^		CAL	Touch the [ENT] key, and "CAL" will be displayed. To cancel the above, touch the [>] key and [ENT] key together to return to the B10 display.
>	^		CAL	If you touch the [ENT] key again, "CAL" then flashes. To cancel the above, touch the [>] key and [ENT] key together, the display will return to the B10 display.
>	^		SPAn Y	If you touch the [ENT] key again, "SPAn Y" appears (Y is flashing). If you omit the span calibration, touch the [>] key, and change "Y" to "N". If you touch the [ENT] key, the display then jumps to "ZEro Y".
>	^		21.00 %	Touch the [ENT] key to display the calibration gas value, in other words, the span gas concentration set in Subsection 7.10.1, "Calibration Setup". To cancel the above, touch the [>] key and [ENT] key together, then the display returns to "SPAn Y".
>	^		OPEn /20.84	If you touch the [ENT] key, "OPEn" and the currently measured value are displayed alternately. Open the Flow Setting Unit span gas flow valve and adjust the span gas flow to 600 ± 60 ml/min. To do this, loosen the valve lock nut and gently turn the valve control (shaft) counterclockwise. Check the calibration gas flowmeter for confirmation. If the automatic calibration unit is connected, open the span gas solenoid valve, and the measured value changes to the span gas value. When the display becomes stable, proceed to the next step. To cancel the above, touch the [>] key and [ENT] key together, then the display returns to "SPAn Y".
>	^		20.84 %	If you touch the [ENT] key, all the digits flash. At that point, no calibration is conducted yet.

Continue to the next page

Switch operation			Display	Description
>	^	ENT 	ZErO Y	If you touch the [ENT] key again, the flashing stops and "ZErO Y" appears. Close the span gas flow valve. Secure the span gas lock nut for leakage. If the automatic calibration unit is connected, close the span gas solenoid valve. If zero gas calibration is omitted, touch the [>] key to change "Y" to "N". Next, if you touch the [ENT] key, the display jumps to "CALEnd".
>	^	ENT 	0.98 %	Touch the [ENT] key to display the calibration gas value. This value must be the zero gas concentration set in Subsection 7.10.1, "Calibration Setup," earlier in this manual. To cancel the above, touch the [>] key and [ENT] key together, then the display returns to "ZErO Y".
>	^	ENT 	OPEn /0.89	If you touch the [ENT] key, "OPEn" and the currently measured value are displayed alternately. Open the Flow Setting Unit zero gas flow valve and adjust the zero gas flow to 600 ± 60 ml/min. To do this, loosen the valve lock nut and gently turn the valve control (shaft) counterclockwise. Check the calibration gas flowmeter for confirmation. If the automatic calibration unit is connected, open the zero gas solenoid valve, and then the measured value changes to the zero gas value. When the display becomes stable, proceed to the next step. To cancel the above, touch the [>] key and [ENT] key together, then the display returns to "ZErO Y".
>	^	ENT 	0.89 %	If you touch the [ENT] key, all the digits flash. At that point, no calibration is conducted yet.
>	^	ENT 	CALEnd	Touch the [ENT] key again to get the measured value to agree with the zero gas concentration. Close the zero gas flow valve. Secure the valve lock nut for leakage during measurement. If the automatic calibration unit is connected, close the zero gas solenoid valve. "CALEnd" flashes during the output hold time. If "output hold" is specified in the "Output Hold Setting," it remains as an analog output (see Section 8.3). When the preset output hold time is up, the calibration is complete.
> 	^	ENT 	b10	The output hold time is set to 10 minutes at the factory. If you touch both the [>] key and [ENT] key at the same time during the preset Output Hold Time, the calibration is aborted and the parameter code selection display appears.
> 	^	ENT 	Basic panel display	If you touch the [>] key and [ENT] key together, then the basic panel display appears.

The above "display" is a result of switch operations.

The symbol [] indicates the keys are being touched, and the light characters indicate "flashing."

"/" indicates that the characters are displayed alternately.

[Cancel] indicates the procedure to stop the key operations.

8. Detailed Data Setting

8.1 Setting Display Item

Display items are defined as items displayed on the basic panel display.

Parameter code [A00] or [F08] is used to set the display items as shown in Table 8.1. The oxygen concentration is set at the factory before shipment. In addition, if the data initialization is performed, the oxygen concentration will be set.

Table 8.1 Display Item

Values set with A00 or F08	Items displayed on the basic panel display
0	Indicates the oxygen concentration.
1 or 2	For humidity analyzers only. (if 1 or 2 is set for the oxygen analyzer, "0.0" is only displayed on the basic panel display.)
3	Displays an item for the current output. If the output damping has been set for the current output, values involving the output damping are displayed.

CAUTION

If you set "3" in the parameter code [A00] or [F08], be sure to select "Oxygen Concentration" in the following mA output setting (see Section 8.2, "Current Output Setting").

8.2 Current Output Setting

This section describes setting of the analog output range. Table 8.2 shows parameter codes for the set items.

Table 8.2 Current Output Parameter Codes

Set item	Parameter code	Set value	
Analog output	C01	0	Oxygen concentration
		1	4 mA (fixed *1)
		2	4 mA (fixed *1)
Output mode	C03	0	Linear
		1	Logarithm
Min. oxygen concentration	C11	Oxygen concentration at 4 mA	
Max. oxygen concentration	C12	Oxygen concentration at 20 mA	
Output damping constant	C30	0 to 255 seconds	

*1: For the oxygen analyzer, set 0 (zero) only for parameter code C01.
When it is set, the current output is 4-mA fixed regardless of the oxygen concentration.

8.2.1 Setting Minimum Oxygen Concentration (at 4 mA) and Maximum Oxygen Concentration (at 20 mA)

Set the oxygen concentration values at 4 mA and 20 mA.

The minimum concentration of oxygen for the minimum current (4 mA) is 0%O₂ or 6% to 76%O₂. The maximum concentration of oxygen for the maximum current (20 mA) ranges from 5% to 100% O₂, and must be greater than 1.3 times the concentration of oxygen set for the minimum. If it does not fall within this input range setting, the setting will be invalid, and the previous set values will remain.

Setting example 1

If the setting (for a 4 mA current) is 10%O₂, you must set the oxygen concentration for the maximum (20 mA) point at 13%O₂.

Setting example 2

If the setting (for a 4 mA current) is 75%O₂, you must set the oxygen concentration for the maximum (20 mA) point at 98%O₂ (75 × 1.3).

(Numbers after the decimal point are rounded up.)

CAUTION

When you select logarithmic mode, the minimum output remains constant at 0.1 % O₂, and the parameter [C11] display remains unchanged.

8.2.2 Entering Output Damping Constants

If a measured value adversely affected by a rapid change in the sample gas oxygen concentration is used for the control means, frequent on-off actions of the output will result. To avoid this, the analyzer allows the setting of output damping constants ranging from 0 to 255 seconds.

8.2.3 Selection of Output Mode

You can select a linear or logarithmic output mode. The former provides linear characteristics between the analog output signal and oxygen concentration.

8.2.4 Default Values

When the analyzer is delivered or data are initialized, the current output settings are by default as shown in Table 8.3.

Table 8.3 Current Output Default Values

Item	Default setting
Min. oxygen concentration	0%O ₂
Max. oxygen concentration	25%O ₂
Output damping constant	0 (seconds)
Output mode	Linear

CAUTION

When you select logarithmic mode, the minimum output remains constant at 0.1%O₂, and the parameter [C11] display remains unchanged.

8.3 Output Hold Setting

The “output hold” functions retain an analog output signal at a preset value during the equipment’s warm-up time or calibration or if an error arises.

Table 8.4 shows the analog outputs that can be retained and the individual states.

Table 8.4 Analog Output Hold Setting

Equipment status Output hold values available	During warm-up	During maintenance	During calibration	During error occurrence (*1)
4 mA	○			
20 mA	○			
Without hold feature		○	○	○
Retains output from just before occurrence		○	○	○
Preset value (2.4 to 21.6 mA)	○	○	○	○

○: The output hold functions are available.

*1: The output hold functions on error occurrence are unavailable when option code “/C2” or “/C3” (NAMER NE 43 compliant) is specified.

8.3.1 Definition of Equipment Status

- (1) During warm-up
“During warm-up” is the time required after applying power until the sensor temperature stabilizes at 750°C, and the equipment is in the measurement mode. This status is that the sensor temperature is displayed on the basic panel.
- (2) During maintenance
“During maintenance” is the time from when a valid password is entered in the basic panel display to enable the parameter code selection display until the display goes back to the basic panel display
- (3) During calibration (see Chapter 9, Calibration)
In the manual calibration, proceed with the calibration operation with the parameter code [B10] to display the span gas confirmation display for the first span calibration, thus starting the calibration time when the [ENT] key is touched. After a series of calibrations is complete and the preset output stabilization time has elapsed, the calibration time will be up. Figure 8.1 shows the definition of “during calibration” in the manual calibration.

Switch operation			Display
>	^	ENT	b10
>	^	ENT	CAL
>	^	ENT	CAL
>	^	ENT	SPAn Y
>	^	ENT	21.00 %
>	^	ENT	OPEn/20.84
>	^	ENT	20.84 %
>	^	ENT	ZERo Y
>	^	ENT	0.98 %
>	^	ENT	OPEn/0.89
>	^	ENT	0.89 %
>	^	ENT	CALEnd
>	^	ENT	b10
>	^	ENT	Basic panel display

Output hold time during calibration

Figure 8.1 Definition of During Calibration

In a semi-automatic calibration, “during calibration” is the time, starting when a calibration instruction is executed with an infrared switch or a contact input, to make a series of calibrations, until the preset output stabilization time elapses.

In an automatic calibration, “during calibration” is the time, starting when automatic calibration is carried out at the calibration start time, until the preset output stabilization time elapses.

- (4) “Error” appears when Err-01 to Err-04 are being issued

8.3.2 Preference Order of Output Hold Value

The output hold value takes the following preference order:

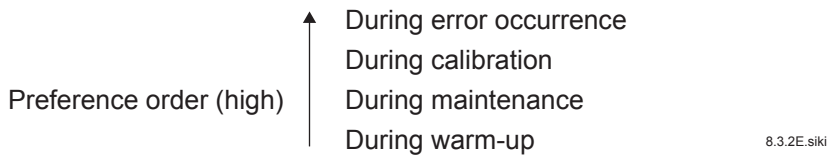

For example, if the current output is set to “4 mA” during maintenance, and “without hold” output during calibration is preset, the output is held at 4 mA in the maintenance display. However, the output hold is released at the time of starting the calibration, and the output will be held again at 4 mA after completing the calibration and when the output stabilization time elapses.

8.3.3 Output Hold Setting

Table 8.5 lists parameter codes with set values for individual set items.

Table 8.5 Parameter Codes for Output Holding

Set items	Parameter code	Set value	
During warm-up	C04	0	4 mA
		1	20 mA
		2	Holds Set value
During maintenance	C05	0	Without hold feature
		1	Last measured value
		2	Holds set values
During calibration	C06	0	Without hold feature
		1	Last measured value
		2	Holds set values
During error occurrence	C07	0	Without hold feature
		1	Last measured value
		2	Holds set values

Note: “C07” is not displayed when option code “/C2” or “/C3” (NAMUR NE 43 compliant) is specified.

8.3.4 Default Values

When the analyzer is delivered, or if data are initialized, output holding is by default as shown in Table 8.6.

Table 8.6 Output Hold Default Values

Status	Output hold (min. and max. values)	Preset value
During warm-up	4 mA	4 mA
During maintenance	Holds output at value just before maintenance started	4 mA
During calibration	Holds output at value just before starting calibration	4 mA
During error occurrence	Holds output at a preset value	3.4 mA

8.4 Oxygen Concentration Alarms Setting

The analyzer enables the setting of four alarms — high-high, high, low, and low-low alarms — depending upon the oxygen concentration. The following section sets forth the alarm operations and setting procedures.

8.4.1 Setting the Alarm Values

- (1) High-high and high alarm values
High-high alarms and high alarms are issued when they are set to be detected with parameter codes [D41] and [D42], and if the measured values exceed the preset oxygen concentration values specified with [D01] and [D02].
The oxygen alarm set values can range from 0 to 100%O₂.
- (2) Low and low-low alarm values
Low alarms and low-low alarms are issued when they are set to be detected with parameter codes [D43] and [D44], and if the measured values are lower than the preset oxygen concentration values specified with [D03] and [D04].
The oxygen alarm set values can be set in the range of 0 to 100%O₂.

8.4.2 Alarm Output Actions

If the measured values of the oxygen concentration fluctuate between normal (steady-state) values and alarm setting, there may be a lot of alarm-output issuing and canceling. To avoid this, set the delay time and allow for hysteresis for alarm canceling under the alarm output conditions, as Figure 8.2 shows.

When the delay time is set, an alarm will not be issued so quickly even if the measured value differs from the steady-state and enters the alarm setpoint range.

If the measured value remains within the alarm setpoint range for a certain period of time (for the preset delay time), an alarm will result.

On the other hand, there will be a similar delay each time the measured value returns to the steady state from the alarm setpoint range (canceling the alarm status).

If hysteresis is set, alarms will be canceled when the measured value is less than or more than the preset hysteresis values.

If both the delay time and hysteresis are set, an alarm will be issued if the measured value is in the alarm setpoint range and the delay time has elapsed.

When the alarm is reset (canceled), it is required that the measured value be beyond the preset hysteresis value and that the preset delay time.

Refer to Figure 8.2 for any further alarm output actions. The delay time and hysteresis settings are common to all alarm points.

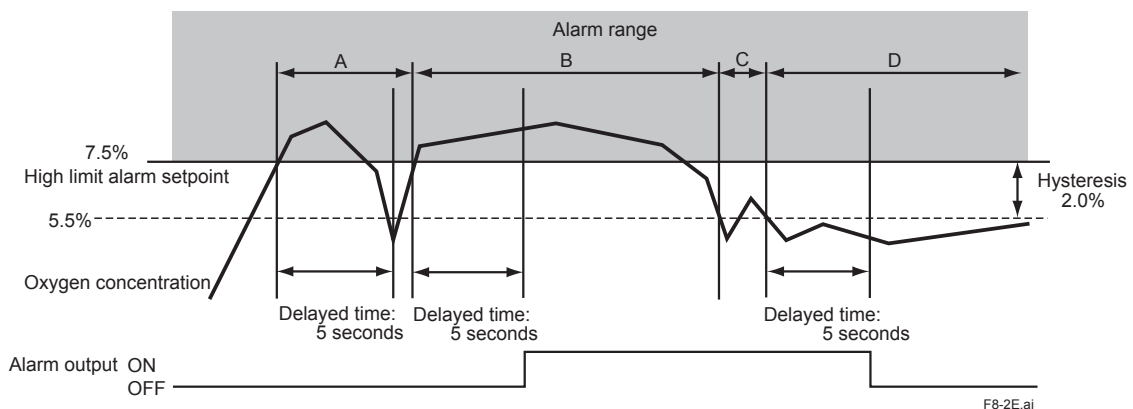

Figure 8.2 Alarm Output Action

In the example in Figure 8.2, the high alarm point is set to 7.5vol%O₂, the delayed time is set to five seconds, and hysteresis is set to 2vol%O₂.

Alarm output actions in this figure are expressed as follows:

- A. Although the oxygen concentration value exceeds the high limit alarm setpoint, it falls below the high limit alarm setpoint before the preset delay time of five seconds elapses. So, no alarm is issued.
- B. The oxygen concentration value exceeds the high limit alarm setpoint and the delay time elapses during that measurement. So, an alarm is issued.
- C. Although the oxygen concentration value falls below the hysteresis set value, the value rises again and exceeds the hysteresis set value before the preset delay time elapses. So, the alarm is not canceled.
- D. The oxygen concentration value falls below the hysteresis set value and the preset delay time elapses, so the alarm is canceled.

8.4.3 Alarm Setting

Set the alarm setpoints following Table 8.7 listing parameter codes.

Table 8.7 Parameter Codes for Oxygen Concentration Alarms

Set item	Parameter code	Set value	
Oxygen concentration high-high alarm setpoint	D01	0-100%O ₂	
Oxygen concentration high alarm setpoint	D02	0-100%O ₂	
Oxygen concentration low alarm setpoint	D03	0-100%O ₂	
Oxygen concentration low-low alarm setpoint	D04	0-100%O ₂	
Oxygen concentration alarm hysteresis	D30	0-9.9%O ₂	
Delayed alarm action	D33	0-255 seconds	
Oxygen concentration high-high alarm detection	D41	0	Not detected
		1	Detected
Oxygen concentration high alarm detection	D42	0	Not detected
		1	Detected
Oxygen concentration low alarm detection	D43	0	Not detected
		1	Detected
Oxygen concentration low-low alarm detection	D44	0	Not detected
		1	Detected

 **CAUTION**

Even with alarms set, if “Not detected” has been set in the above alarm detection, no alarm is issued. Be sure to set “Detected” in the above alarm detection if you use alarm features.

8.4.4 Default Values

When the analyzer is delivered, or if data are initialized, the default alarm set values are as shown in Table 8.8.

Table 8.8 Alarm Setting Default Values

Set item	Set value
High-high alarm setpoint	100%O ₂
High alarm setpoint	100%O ₂
Low alarm setpoint	0%O ₂
Low-low alarm setpoint	0%O ₂
Alarm hysteresis	0.1%O ₂
Delayed alarm action	3 seconds
High-high alarm detection	Not detected
High alarm detection	Not detected
Low alarm detection	Not detected
Low-low alarm detection	Not detected

8.5 Contact Output Setting

8.5.1 Contact Output

Mechanical relays provide contact outputs. Be sure to observe relay contact ratings. (For details, see Section 2.1, "General Specifications".) The following sets forth the operation mode of each contact output. Contact output 1 you can select open or closed contact when the contact is "operated".

For contact output 2, contact is closed. The relay for contact output 1 is energized when its contacts are closed and vice versa. Accordingly, when no power is supplied to the equipment, those contacts remain open. In addition, the relay for contact output 2 is energized when the corresponding contact is open and de-energized when that contact is closed.

Table 8.9 Setting Contact Outputs

	Operating state	When no power is applied to this equipment
Contact output 1	Open (de-energized) or closed (energized) selectable.	Open
Contact output 2	Closed (de-energized) only.	Closed

8.5.2 Setting Contact Output

Set the contact outputs following Table 8.10.

Table 8.10 Parameter Codes for Contact Output Setting

Set item	Parameter code	Set value	
Contact output 1			
Operation	E10	0	Operated in closed status. (Normally de-energized)
		1	Operated when open. (Normally energized) (Note 1)
Error	E20	0	Not operated if an error occurs.
		1	Operated if an error occurs.
High-high alarm	E21	0	Not operated if a high-high alarm occurs.
		1	Operated if a high-high alarm occurs. (Note 2)
High alarm	E22	0	Not operated if a high alarm occurs.
		1	Operated if a high alarm occurs. (Note 2)
Low alarm	E23	0	Not operated if a low alarm occurs.
		1	Operated if a low alarm occurs. (Note 2)
Low-low alarm	E24	0	Not operated if a low-low alarm occurs.
		1	Operated if a low-low alarm occurs. (Note 2)
During maintenance	E25	0	Not operated during maintenance.
		1	Operated during maintenance (see Subsection 8.3.1).
During calibration	E26	0	Not operated during calibration.
		1	Operated during calibration (see Subsection 8.3.1).
Output range change	E27	0	Not operated when changing ranges.
		1	Operated when changing ranges. (Note 3)
During warm-up	E28	0	Not operated during warming up.
		1	Operated during warming up.
Calibration gas pressure decrease	E29	0	Not operated while a calibration gas pressure decrease, contact is being closed.
		1	Operated while a calibration gas pressure decrease, contact is being closed. (Note 4)
Unburnt gas detection	E32	0	Not operated while an unburnt gas detection, contact is being closed.
		1	Operated while an unburnt gas detection, contact is being closed. (Note 5)

Note 1: Contact output 2 remains closed.

Note 2: The oxygen concentration alarm must be preset (see Section 8.4).

Note 3: Range change answer-back signal. For this action, the range change must be preset during the setting of contact inputs (see Section 8.5).

Note 4: Calibration gas pressure decrease answer-back signal. Calibration gas pressure decrease must be selected beforehand during the setting of contact inputs.

Note 5: Non-combusted gas detection answer-back signals. "Non-combusted gas" detection must be selected during the setting of contact inputs.

WARNING

Contact output 2 is linked to the detector's heater power safety switch. As such, if contact output 2 is on, the heater power stops and an Err-01 (cell voltage abnormal) or Err-02 (heater temperature abnormal) occurs.

8.5.3 Default Values

When the analyzer is delivered, or if data are initialized, contact outputs are by default as shown in Table 8.11.

Table 8.11 Contact Output Default Settings

Item	Contact output 1	Contact output 2
High-high alarm		
High alarm		
Low alarm		
Low-low alarm		
Error		○
During warm-up	○	
Output range change		
During calibration		
During maintenance	○	
Calibration gas pressure decrease		
Unburnt gas detection		
Operating contact status	Open	Closed (fixed)

○: Present

NOTE

The above blank boxes indicate the items have been set off.

8.6 Contact Input Setting

The analyzer contact inputs execute set functions by accepting a remote (contact) signal. Table 8.12 shows the functions executed by a remote contact signal.

Table 8.12 Contact Input Functions

Set item	Function
Calibration gas pressure decrease	While a contact signal is on, neither semi-automatic nor automatic calibrations can be made.
Measuring range change	While contact input is on, the analog output range is switched to 0-25%O ₂ .
Calibration start	If a contact signal is applied, semi-automatic calibration starts (only if the semi-automatic or automatic mode has been setup). Contact signal must be applied for at least one second. Even though a continuous contact signal is applied, a second calibration cannot be made. If you want to make a second calibration, turn the contact signal off and then back on.
Unburnt gas detection	If a contact signal is on, the heater power will be switched off. (An one-to 11-second time interval single-output signal is available as a contact signal.) If this operation starts, the sensor temperature decreases and an error occurs. To restore it to normal, turn the power off and then back on, or reset the analyzer.

CAUTION

To conduct a semi-automatic calibration, be sure to set the Calibration setup mode to “Semi-automatic” or “Automatic”.

8.6.1 Setting Contact Input

To set the contact inputs, follow the parameter codes given in Table 8.13.

Table 8.13 Parameter Codes for Contact Input Settings

Set item	Parameter code	Set value	
		Value	Description
Contact input 1 (function)	E01	0	Invalid
		1	Calibration gas pressure decrease
		2	Measuring range change
		3	Calibration
		4	Unburnt gas detection
Contact input 2 (function)	E02	0	Invalid
		1	Calibration gas pressure decrease
		2	Measuring range change
		3	Calibration
		4	Unburnt gas detection
Contact input 1 (action)	E03	0	Operated when closed
		1	Operated when open
Contact input 2 (action)	E04	0	Operated when closed
		1	Operated when open

8.6.2 Default Values

When the analyzer is delivered, or if data are initialized, the contact inputs are all open.













8.7 Other Settings

8.7.1 Setting the Date-and-Time

The following describe how to set the date-and-time. Automatic calibration works following this setting.

Use parameter code [F10] to set the date-and-time.

Table 8.14 Data-and-time Settings

Switch operation			Display	Description
>	^	ENT	F10	Select the parameter code F10.
>	^	ENT 	00.01.01	If you touch the [ENT] key, the current date will be displayed. The display on the left indicates the date - January 1, 2000. To set June 21, 2000, follow the steps below:
	^	ENT	00.01.01	Touch the [>] key to move the position of the digit that is flashing to the right.
>		ENT	00.06.01	Touch the [^] key to change to 6.
	^	ENT	00.06.01	Touch the [>] key to move the position of the digit that is flashing to the right one digit.
>		ENT	00.06.21	Touch the [^] key to change to 2.
	^	ENT	00.06.21	Touch the [>] key to move the position of the digit that is flashing to the right one digit.
	^	ENT	07.18	Let the rightmost character flash, and touch the [>] key to display the time. Continuously touch the [>] key, then the date and time are alternately displayed. Displayed on the left is 7:18 a.m.
Omitted here.				
>		ENT	14.30	Touch the [^] key and enter the current time in same way as the date has been entered, on a 24-hour basis. 2:30 p.m. Displayed on the left means 2:40 p.m.
>	^	ENT 	14.30	If you touch the [ENT] key, all the digits flash.
>	^	ENT 	14.30	Touch the [ENT] key again to set the time.
	^	ENT 	F10	If you touch the [>] and [ENT] keys together, the parameter code selection display appears.

The symbol () indicates that the corresponding keys are being touched, and the light characters indicate flashing.

8.7.2 Setting Periods over which Average Values are Calculated and Periods over which Maximum and Minimum Values Are Monitored

The equipment enables the display of oxygen concentration average values and maximum and minimum values under measurement (see Subsection 10.1.1, later in this manual). The following section describes how to set the periods over which oxygen concentration average values are calculated and maximum and minimum values are monitored.

Procedure

Use the parameter-code table below to set the average, maximum and minimum oxygen concentration values. Periods over which average is calculated and periods over which maximum and minimum values are monitored can be set, ranging from 1 to 255 hours. If the set ranges are beyond the limits specified, an “Err” will be displayed.

Table 8.15 Parameter Codes for Average, Maximum and Minimum Values

Set item	Parameter code	Set range	Units
Periods over which average values are calculated	F11	1 to 255	Hours
Periods over which maximum and minimum values are monitored	F12	1 to 255	Hours

Default Value

When the analyzer is delivered, or if data are initialized, periods over which average values are calculated are set to one hour, and periods over which maximum and minimum values are monitored are set to 24 hours.

8.7.3 Setting Fuels

Input Parameters

The analyzer calculates the moisture content contained in exhaust gases.

The following sets forth the fuel parameters necessary for calculation and their entries.

The moisture quantity may be mathematically expressed by:

$$\begin{aligned} \text{Moisture quantity} &= \frac{\overbrace{\text{(water vapor caused by combustion and water vapor contained in the exhaust gas)}} + \text{(water vapor contained in air for combustion)}}{\text{actual exhaust gas(including water vapor) per fuel}} \times 100 \\ &= \frac{G_w + G_{w1}}{G} \times 100 \\ &= \frac{G_w + (1.61 \times Z \times m \times A_o)}{G_o + G_w + (m - 1) A_o + (1.61 \times Z \times m \times A_o)} \times 100 \quad \dots\dots\dots \text{Equation 1} \\ &\doteq \frac{\boxed{G_w} + (1.61 \times \boxed{Z} \times m \times \boxed{A_o})}{\boxed{X} + \boxed{A_o} \times m} \times 100 \quad \dots\dots\dots \text{Equation 2} \end{aligned}$$

where,

$\boxed{A_o}$: Theoretical amount of air per unit quantity of fuel, m³/kg (or m³ /m³) ② in Table 8.8

G: Actual amount of exhaust gas (including water vapor) per unit quantity of fuel, m³/kg (or m³ /m³)

$\boxed{G_w}$: Water vapor contained in exhaust gas per unit quantity of fuel (by hydrogen and moisture content in fuel), m³/kg (or m³ /m³) ① in Table 8.8

G_{w1}: Water vapor contained in exhaust gas per unit quantity of fuel (moisture content in air), m³/kg (or m³ /m³)

G_o: Theoretical amount of dry exhaust gas per unit quantity of fuel, m³/kg (or m³ /m³)

m: Air ratio

\boxed{X} : Fuel coefficient determined depending on low calorific power of fuel, m³/kg (or m³ /m³) ... ③ in Table 8.8

\boxed{Z} : Absolute humidity of the atmosphere, kg/kg Figure 8.17

8.7.3E.siki

Fill in the boxes with fuel parameters in Equation 2 above to calculate the moisture content. Use A_o, G_w and X shown in Table 8.16. If there are no appropriate fuel data in Table 8.16, use the following equations for calculation.

Find the value of “Z” in Equations 1 and 2 using Japanese Industrial Standards JIS B 8222. If a precise measurement is not required, obtain the value of “Z” using a graph for the absolute humidity indicated by a dry and wet bulb hygrometer.

• For liquid fuel

$$\text{Amount of water vapor in exhaust gas (Gw)} = (1/100) \{1.24 (9h + w)\} \quad [\text{m}^3/\text{kg}]$$

$$\text{Theoretical amount of air (Ao)} = \{(12.38 / 10000) \times H1\} - 1.36 \quad [\text{m}^3/\text{kg}]$$

$$\text{Low calorific power} = H1$$

$$\text{X value} = \{(3.37 / 10000) \times Hx\} - 2.55 \quad [\text{m}^3/\text{kg}]$$

where, H1: low calorific power of fuel

h: Hydrogen in fuel (weight %)

w: Moisture content in fuel (weight %)

Hx: Same as numeric value of H1

• For gaseous fuel

$$\text{Amount of water vapor in exhaust gas} = (1/100) \{(h2) + 1/2 \sum y (Cy hy) + w\} \quad [\text{m}^3/\text{m}^3]$$

$$\text{Theoretical amount of air} = 11.2 \times (H1/10000) \quad [\text{m}^3/\text{m}^3]$$

$$\text{Low calorific power} = H1$$

$$\text{X value} = (1.05 / 10000) \times Hx \quad [\text{m}^3/\text{m}^3]$$

where, H1: low calorific power of fuel

h: Hydrogen in fuel (weight %)

w: Moisture content in fuel (weight %)

Hx: Same as numeric value of H1

• For solid fuel

$$\text{Amount of water vapor in exhaust gas (Gw)} = (1/100) \{1.24 (9h + w)\} \quad [\text{m}^3/\text{kg}]$$

$$\text{Theoretical amount of air} = \{(1.01 \times (H1 / 1000))\} + 0.56 \quad [\text{m}^3/\text{kg}]$$

$$\text{Low calorific power} = H1 = Hh - 25 (9h + w) \quad [\text{kJ}/\text{kg}]$$

$$\text{X value} = 1.11 - (0.106 / 1000) \times Hx \quad [\text{m}^3/\text{m}^3]$$

where, w: Total moisture content in use (weight %)

h: Hydrogen content (weight %)

The average hydrogen content of coal mined in Japan, which is a dry ash-free type, is 5.7 %. Accordingly, "h" may be expressed mathematically by:

$$h = 5.7 \left[\frac{100 - (w + a)}{100} \times \frac{(100 - w)}{(100 - w1)} \right]$$

where, a: Ash content [%]

w1: Moisture content [%], analyzed on a constant humidity basis

Hh: Higher calorific power of fuel [kJ/kg]

H1: Low calorific power of fuel [kJ/kg]

Hx: Same numeric value of H1

F8-3E.ai

Figure 8.3 Fuel Calculation Formula

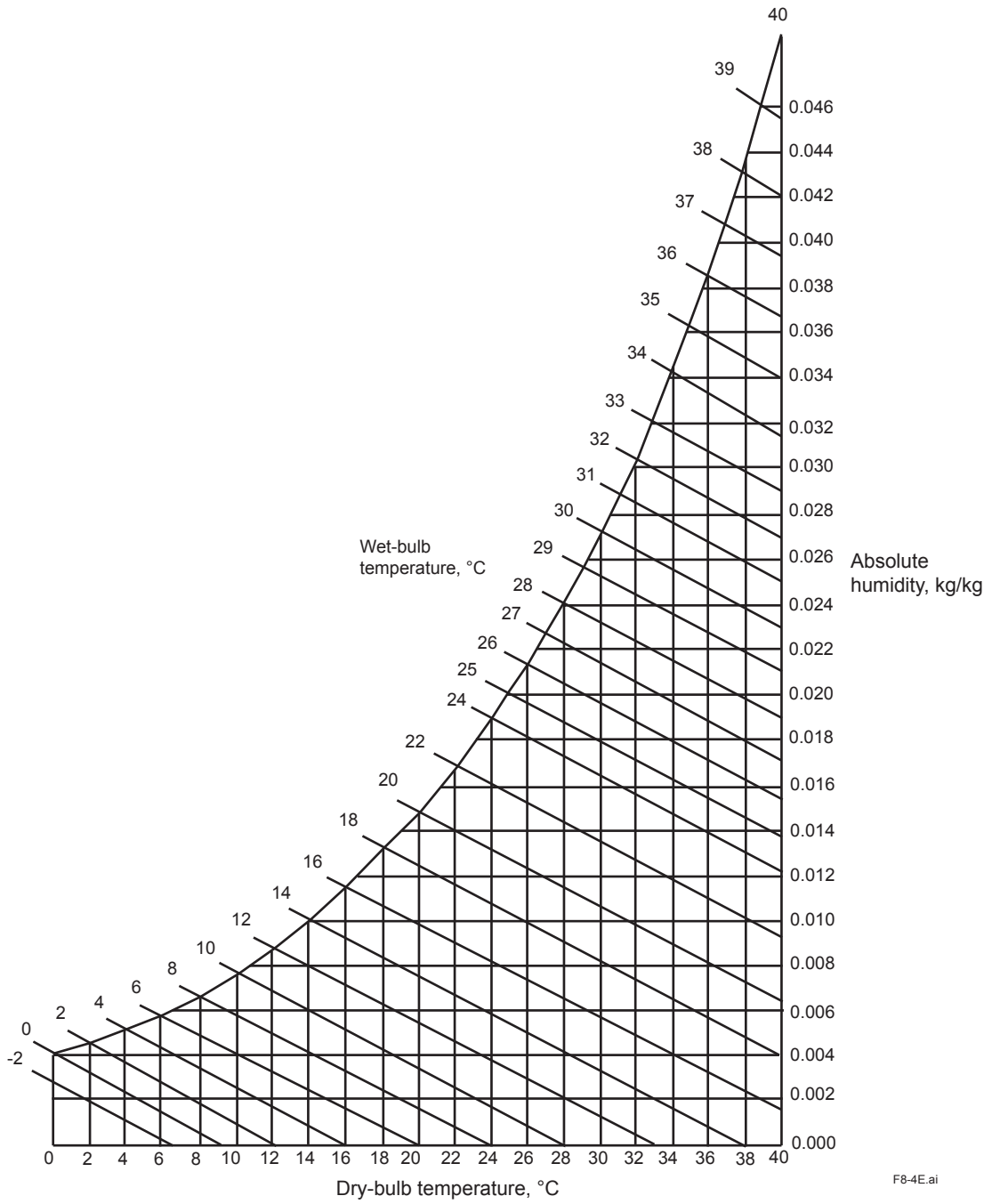

Figure 8.4 Absolute Humidity of Air

F8-4E.ai

Table 8.16 Fuel Data

● For liquid fuel

Fuel properties Type			Specific weight kg/l	Chemical component (weight percentage)							Calorific power kJ/kg		Theoretical amount of air for combustion Nm ³ /kg	Amount of combustion gas Nm ³ /kg					X value
				C	H	O	N	S	w	Ash content	Higher order	Lower order		CO ₂	H ₂ O	SO ₂	N ₂	Total	
Kerosene			0.78~0.83	85.7	14.0	—	—	0.5	0.0	0.0	46465	43535	11.4	1.59	1.56	0.00	9.02	12.17	0.96
Light oil			0.81~0.84	85.6	13.2	—	—	1.2	0.0	0.0	45879	43032	11.2	1.59	1.47	0.00	8.87	11.93	0.91
A	Heavy oil class 1	No.1	0.85~0.88	85.9	12.0	0.7	0.5	0.5	0.3	0.05	45544	42739	10.9	1.60	1.34	0.00	8.61	11.55	0.89
		No.2	0.83~0.89	84.6	11.8	0.7	0.5	2.0	0.4	0.05	45125	42320	10.8	1.58	1.32	0.01	8.53	11.44	0.86
B	Heavy oil class 2		0.90~0.93	84.5	11.3	0.4	0.4	3.0	0.5	0.05	43827	41274	10.7	1.58	1.27	0.02	8.44	11.31	0.77
C	Heavy oil class 3	No.1	0.93~0.95	86.1	10.9	0.5	0.4	1.5	0.5	0.1	43952	41441	10.7	1.61	1.22	0.01	8.43	11.27	0.79
		No.2	0.94~0.96	84.4	10.7	0.5	0.4	3.5	0.5	0.1	43116	40646	10.5	1.58	1.20	0.02	8.32	11.12	0.72
		No.3	0.92~1.00	86.1	10.9	0.5	0.4	1.5	0.6	0.1	43660	41190	10.7	1.61	1.22	0.01	8.43	11.27	0.77
		No.4	0.94~0.97	83.0	10.5	0.5	0.4	3.5	2.0	0.1	43032	40604	10.3	1.55	1.18	0.02	8.18	10.93	0.72

②

①

③

● For gas fuel

Fuel properties Type			Specific weight kg/Nm ³	Chemical component (weight percentage)							Calorific power kJ/Nm ³		Theoretical amount of air for combustion Nm ³ /m ³	Combustion product, Nm ³ /m ³				X value	
				CO	H ₂	CO ₂	CH ₄	C _m H _n	O ₂	N ₂	Higher order	Lower order		CO ₂	H ₂ O	N ₂	Total		
Coke oven gas			0.544	9.0	50.5	2.6	25.9	3.9	0.1	8.0	20428	18209	4.455	0.45	1.10	3.60	5.15	0.46	
Blast furnace gas			1.369	25.0	2.0	20.0	—	—	—	53.0	3391	3349	0.603	0.45	0.02	1.01	1.48	0.08	
Natural gas			0.796	—	—	2.0	88.4	3.2	1.6	4.2	37883	34074	9.015	0.98	1.88	7.17	10.03	0.86	
Propane			2.030	C ₃ H ₈ 90%, C ₄ H ₁₀ 10%							102055	93976	24.63	3.10	4.10	19.5	26.7	2.36	
Butane			2.530	C ₃ H ₈ 10%, C ₄ H ₁₀ 90%							125496	115868	30.37	3.90	4.90	24.0	32.8	2.91	
(Gases)				(Molecular Formula)															
Oxygen			1.43	O ₂							—	—	—	—	—	—	—	—	—
Nitrogen			1.25	N ₂							—	—	—	—	—	—	—	—	—
Hydrogen			0.09	H ₂							12767	10758	2.390	—	1.0	1.89	2.89	0.27	
Carbon monoxide			1.25	CO							12642	12642	2.390	1.0	—	1.89	2.89	0.32	
Carbon dioxide			1.96	CO ₂							—	—	—	—	—	—	—	—	
Methane			0.72	CH ₄							39750	35820	9.570	1.0	2.0	7.57	10.6	0.90	
Ethane			1.34	C ₂ H ₆							69638	63744	16.74	2.0	3.0	13.2	18.2	1.60	
Ethylene			1.25	C ₂ H ₄							62991	59060	14.35	2.0	2.0	11.4	15.4	1.48	
Propane			1.97	C ₃ H ₈							99070	91255	23.91	3.0	4.0	18.9	25.9	2.29	
Butane			2.59	C ₄ H ₁₀							128452	118623	31.09	4.0	5.0	24.6	33.6	2.98	

②

①

③

Procedure

Use the parameter code table below to set fuel values.

Table 8.17 Setting Fuel Values

Set item	Parameter code	Set value	Engineering units
Amount of water vapor in exhaust gas	F20	0 to 5	m ³ /kg (m ³)
Theoretical amount of air	F21	1 to 20	m ³ /kg (m ³)
X value	F22	0 to 19.99	
Absolute humidity of the atmosphere	F23	0 to 1	kg/kg

Default Values

When the analyzer is delivered, or if data are initialized, parameter settings are by default, as shown in Table 8.18.

Table 8.18 Default Settings of Fuel Values

Item	Default setting
Amount of water vapor in exhaust gas	1.00 m ³ /kg (m ³)
Theoretical amount of air	1.00 m ³ /kg (m ³)
X value	1.00
Absolute humidity of the atmosphere	0.1000 kg/kg

8.7.4 Setting Purging

Purging is to remove condensed water in the calibration gas pipe by supplying a span calibration gas for a given length of time before warm-up of the detector. This prevents cell breakage during calibration due to condensed water in the pipe.

Open the solenoid valve for the automatic calibration span gas during purging and after the purge time has elapsed, close the valve to start warm-up.

Purging is enabled when the cell temperature is 100°C or below upon power up and the purge time is set in the range of 1 to 60 minutes.

Displayed alternately

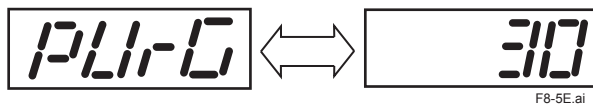

Figure 8.5 Display during Purging

Procedure

Use the parameter-code table below to set the purging time. The allowable input ranges from 0 to 60 minutes.

Table 8.19 Purging Time

Set item	Parameter code	Set range	Units
Purging time	F15	0 to 60	minutes

Default Value

When the analyzer is delivered, or if data are initialized, purging time is set to 0 minutes.

9. Calibration

9.1 Calibration Briefs

9.1.1 Principle of Measurement

This subsection sets forth the principles of measurement with a zirconia oxygen analyzer before detailing calibration.

A solid electrolyte such as zirconia allows the conductivity of oxygen ions at high temperatures. Therefore, when a zirconia-plated element with platinum electrodes on both sides is heated up in contact with gases having different oxygen partial pressures on each side, the element shows the action of the concentration cell. In other words, the electrode in contact with a gas with a higher oxygen partial pressure acts as a negative electrode. As the gas comes in contact with the zirconia element in this negative electrode, oxygen molecules in the gas acquire electrons and become ions. Moving in the zirconia element, they eventually arrive at the positive electrode on the opposite side.

There, the electrons are released and the ions return to the oxygen molecules. This reaction is indicated as follows:

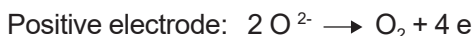
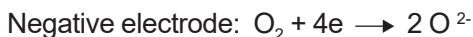

The electromotive force E (mV) between the two electrodes, generated by the reaction, is governed by Nernst's equation as follows:

$E = -RT/nF \ln P_x/P_a$Equation (1)

where,

R: Gas constant

T: Absolute temperature

n: 4

F: Faraday's constant

Px: Oxygen concentration in a gas in contact with the negative zirconia electrode (%)

Pa: Oxygen concentration in a gas in contact with the positive zirconia electrode (%)

Assuming the zirconia element is heated up to 750°C, then we obtain equation (2) below:

$E = -50.74 \log P_x/P_a$Equation (2)

With this analyzer, the sensor (zirconia element) is heated up to 750°C, so Equation (2) is valid. At that point, the relationship as in Figure 9.1 is effected between the oxygen concentration of the measurement gas in contact with the positive electrode and the electromotive force of the sensor (cell), where a comparison gas of air is used on the negative electrode side.

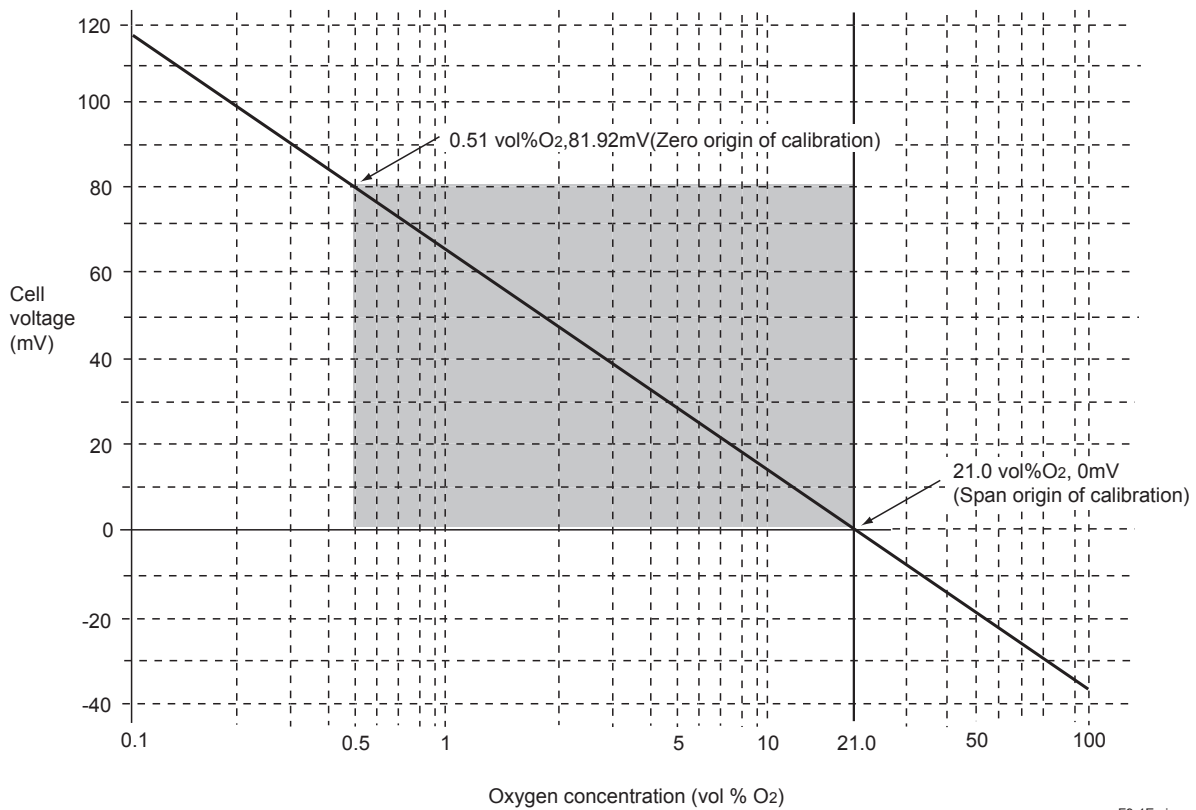

F9-1E.ai

Figure 9.1 Oxygen Concentration in a Measurement Gas vs. Cell Voltage (21 vol%O₂ Equivalent)

The measurement principles of a zirconia oxygen analyzer have been described above. However, the relationship between oxygen concentration and the electromotive force of a cell is only theoretical. Usually, in practice, a sensor shows a slight deviation from the theoretical value. This is the reason why calibration is necessary. To meet this requirement, an analyzer calibration is conducted so that a calibration curve is obtained, which corrects the deviation from the theoretical cell electromotive force.

9.1.2 Calibration Gas

A gas with a known oxygen concentration is used for calibration. Normal calibration is performed using two different gases: a zero gas of low oxygen concentration and a span gas of high oxygen concentration. In some cases, only one of the gases needs to be used for calibration. However, even if only one of the gases is normally used, calibration using both gases should be done at least once.

The zero gas normally used has an oxygen concentration of 0.95 to 1.0 vol%O₂ with a balance of nitrogen gas (N₂). The span gas widely used is clean air (at a dew-point temperature below -20°C and free of oily mist or dust, as in instrument air).

9.1.3 Compensation

The deviation of a measured value from the theoretical cell electromotive force is checked by the method in Figure 9.2 or 9.3.

Figure 9.2 shows a two-point calibration using two gases: zero and span. Cell electromotive forces for a span gas with an oxygen concentration p_1 and a zero gas with an oxygen concentration p_2 are measured while determining the calibration curve passing through these two points. The oxygen concentration of the sample gas is determined from this calibration curve. In addition, the calibration curve corrected by calibration is compared with the theoretical calibration curve for determining the zero correction ratio represented by $B/A \times 100 (\%)$ on the basis of A, B and C shown in Figure 9.2 and a span correction ratio of $C/A \times 100 (\%)$. If the zero correction ratio exceeds the range of $100 \pm 30\%$ or the span correction ratio becomes larger than $0 \pm 18\%$, calibration of the sensor becomes impossible.

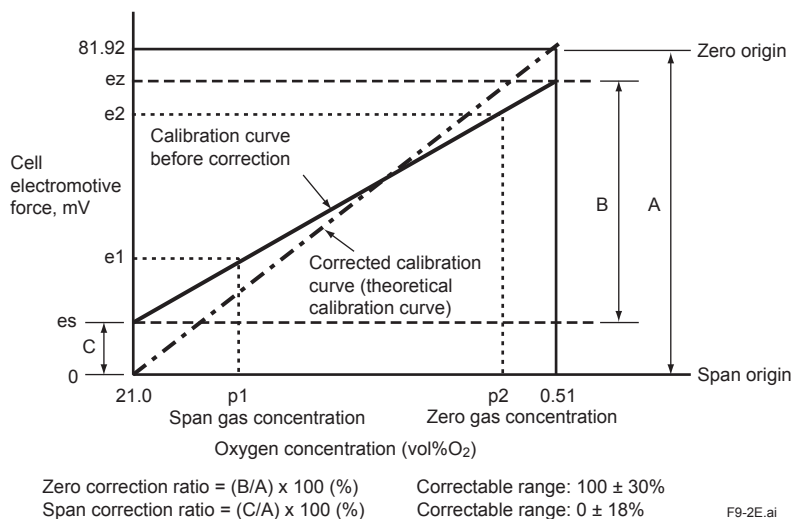

Figure 9.2 Calculation of a Two-point Calibration Curve and Correction Ratios using Zero and Span Gases

Figure 9.3 shows a one-point calibration using only a span gas. In this case, only the cell electromotive force for a span gas with oxygen concentration p_1 is measured. The cell electromotive force for the zero gas is carried over from a previous measurement to obtain the calibration curve. The principle of calibration using only a span gas also applies to the one-point calibration method using a zero gas only.

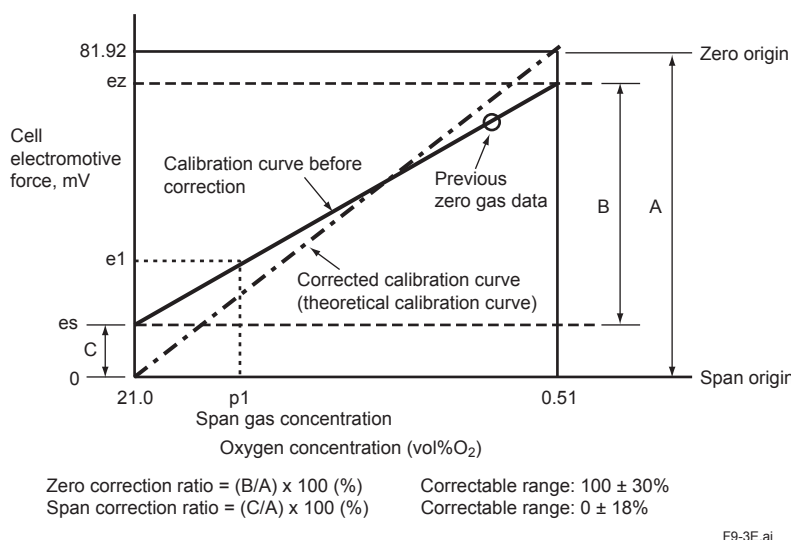

Figure 9.3 Calculation of a One-point Calibration Curve and Correction Ratios Using a Span Gas

9.1.4 Characteristic Data from a Sensor Measured During Calibration

During calibration, calibration data and sensor status data (listed below) are acquired. However, if the calibration is not properly conducted (an error occurs in automatic or semi-automatic calibration), these data are not collected in the current calibration.

These data can be observed using parameter codes [A20] to [A22], and [A50] to [A79]. For an explanation and the operating procedures of individual data, consult Section 10.1, "Detailed Display."

(1) Record of span correction ratio

Recorded the past ten span correction ratios.

(2) Record of zero correction ratio

Recorded the past ten zero correction ratios.

(3) Response time

You can monitor the response time provided that a two-point calibration has been done in semi-automatic or automatic calibration.

(4) Cell's internal resistance

The cell's internal resistance gradually increases as the cell (sensor) deteriorates. You can monitor the values measured during the latest calibration. However, these values include the cell's internal resistance and other wiring connection resistance. So, the cell's degrading cannot be estimated from these values only.

When only a span calibration has been made, these values will not be measured, and previously measured values will remain.

(5) Robustness of a cell

The robustness of a cell is an index for predicting the remaining life of a sensor and is expressed in a number on four levels.

9.2 Calibration Procedures

CAUTION

Calibration should be made under normal operating conditions (if the probe is connected to a furnace, the analyzer will undergo calibration under the operating conditions of the furnace). To make a precise calibration, conduct both zero and span calibrations.

9.2.1 Calibration Setting

The following sets forth the required calibration settings:

Mode

There are three calibration modes available:

- (1) Manual calibration which allows zero and span calibrations or either one manually in turn;
- (2) Semi-automatic calibration which lets calibration start with the touch panel or a contact input, and undergoes a series of calibration operations following preset calibration periods and stabilization time.
- (3) Automatic calibration which is carried out automatically following preset calibration periods.

Calibrations are limited by the following mode selection:

- **When Manual calibration is selected:**
Manual calibration only can be conducted. (This mode does not allow semi-automatic calibration with a contact input nor automatic calibration even when its start-up time has reached.)
- **When Semi-automatic calibration is selected:**
This mode enables manual and semi-automatic calibrations to be conducted. (The mode, however, does not allow automatic calibration even when its start-up time has reached.)
- **When Automatic calibration is selected:**
This calibration can be conducted in any mode.

Calibration Procedure

Select both span and zero calibrations or span calibration only or zero calibration only. Usually select span and zero calibrations.

Zero gas Concentration

Set the oxygen concentration for zero calibration. Enter the oxygen concentration for the zero gas in the cylinder used.

Span gas Concentration

Set the oxygen concentration for span calibration. If instrument air is used as the span gas, enter 21 %O₂.

When using the ZO21S Standard Gas Unit (for use of the atmospheric air as a span gas), use a hand-held oxygen analyzer to measure the actual oxygen concentration, and then enter it.

CAUTION

- When instrument air is used for the span calibration, remove the moisture from the instrument air at a dew-point temperature of -20°C and also remove any oily mist and dust from that air.
- If dehumidifying is not enough, or if foul air is used, the measurement accuracy will be adversely affected.

Calibration Time

- When the calibration mode is in manual:
First set the hold (output stabilization) time. This indicates the time required from the end of calibration to entering a measurement again. This time, after calibration, the measurement gas enters the sensor to set the time until the output returns to normal. The output remains held after completing the calibration operation until the hold (output stabilization) time elapses. The calibration time set ranges from 00 minutes, 00 seconds to 60 minutes, 59 seconds. For more details, consult Section 8.3, "Setting Output Hold."
- When the calibration mode is in semi-automatic:
Set the hold (output stabilization) time and calibration time. The calibration time is the time required from starting the flow of the calibration gas to reading out the measured value. The set calibration time is effective in conducting both zero and span calibrations. The calibration time set ranges from 00 minutes, 00 seconds to 60 minutes, 59 seconds. Figure 9.4 shows the relationship between the calibration time and hold (output stabilization) time.

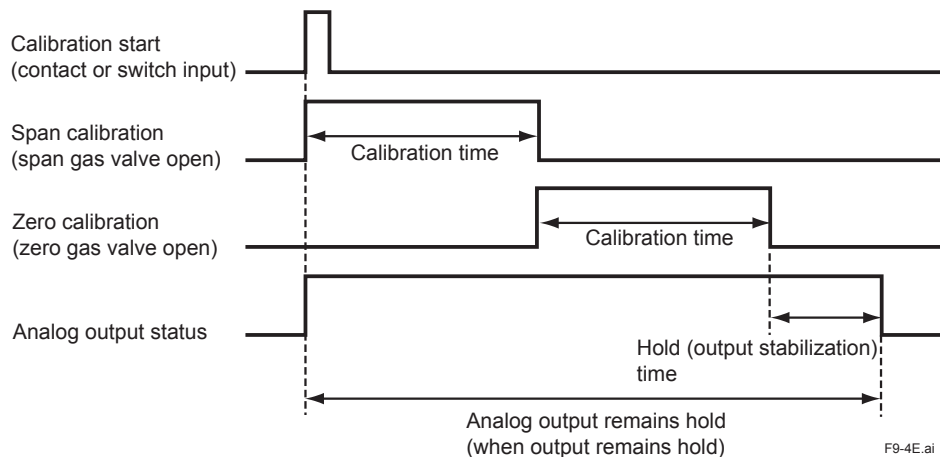

Figure 9.4 Calibration and Hold (Output stabilization) Time Settings

- When the calibration mode is in automatic:
In addition to the above hold (output stabilization) time and calibration time, set the interval, start date, and start time.
Interval means the calibration intervals ranging from 000 days, 00 hours to 255 days, 23 hours.
Set the first calibration day and the start-calibration time to the start date and start time respectively. After the first calibration is carried out, the next calibration will be executed according to the preset calibration intervals.

Setting

When setting calibration timing requirements, bear the following precautions in mind:

NOTE

- If the calibration interval is shorter than the sum of hold (output stabilization) time plus calibration time, the second calibration start time will conflict with the first calibration. In such a case, the second calibration will not be conducted. (When both zero and span calibrations are to be performed, the calibration time is double that required for a single (zero or span) calibration.)
- For the same reason, if the calibration start time conflicts with manual calibration or semi-automatic calibration, the current calibration will not be conducted.
- If the calibration time conflicts with maintenance service operation, calibration will start after completing the maintenance service operation (see Subsection 8.3.1, earlier in this manual).
- If 000 days, 00 hours are set for the calibration intervals, only the first calibration will be conducted; a second or later calibration will not be conducted.
- If a past date is set to the calibration start day, no calibration will be conducted.

Table 9.1 Parameter Codes for Calibration Setting

Set Item	Parameter code	Set value	Engineering unit
Zero gas concentration	B01	Set Zero gas concentration	%O ₂
Span gas concentration	B02	Set Span gas concentration	%O ₂
Calibration mode	B03	0 Manual calibration 1 Semi-automatic and manual 2 Automatic, semi-automatic, and manual	
Hold (Output stabilization) time	B04	0 minutes 0 seconds to 60 minutes 59 seconds	MM.SS
Calibration time	B05	0 minutes 0 seconds to 60 minutes 59 seconds	MM.SS
Calibration interval	B06	0 days 0 hours to 255 days 23 hours	Date and time
Start date and time	B07	Date and time of first calibration	YY.MM. DD.HH.MM
Calibration procedure	B08	0 : Zero and span 1 : Span only 2 : Zero only	

Default Values

When the analyzer is delivered, or if data are initialized, the calibration settings are by default, as shown in Table 9.2.

Table 9.2 Default Settings for Calibration

Item	Default Setting
Calibration mode	Manual
Calibration procedure	Span - zero
Zero gas (oxygen) concentration	1.00%
Span gas (oxygen) concentration	21.00%
Hold (Output stabilization) time	10 minutes, 00 seconds
Calibration time	10 minutes, 00 seconds
Calibration interval	30 days, 00 hours
Start date and time	00 (YY) 01 (MM) 01(DD) 00:00

9.2.2 Calibration



Manual Calibration

For manual calibration, consult Section 7.10, "Calibration," earlier in this manual.

Semi-automatic Calibration

- (1) Calibration startup using infrared switches

Table 9.3 Semi-automatic Calibration Procedure

Switch operation			Display	Description
>	^	ENT	b11	Change the parameter code to b11. (Previous operations omitted)
>	^	ENT 	SA-CAL	Touch the [ENT] key to display "SA-CAL" (Semi Auto CAL).
>	^	ENT 	SPAn /20.84	Touch the [ENT] key again to open the span gas solenoid valve. The span gas then flows. "SPAn" and the currently measured value are alternately displayed. If the "output hold" is set, the output hold will start at this time.
>	^	ENT	ZERo /0.89	If the set calibration time elapses, the span gas solenoid valve closes automatically, the zero gas solenoid valve opens and the zero gas flows. "ZERo" and the currently measured value are displayed alternately.
>	^	ENT	CALEnd	End If the set calibration time elapses, the zero gas solenoid valve then closes automatically. The "CALEnd" flashes until the set output stabilization time elapses.
>	^	ENT	Basic panel display	If the output stabilization time elapses, the basic panel display then appears. Output holding will be released.

The symbol [] indicates that the corresponding keys are being touched, and the light characters indicate flashing. "/" indicates that both are displayed alternately.

- (2) To start calibration using an contact input, follow these steps:
- Make sure that Calibration start has been selected in the contact inputs display (see Section 8.4, earlier in this manual).
 - Apply a contact input to start calibration.
- (3) To stop calibration midway, follow these steps:
- Touch the [>] key and [ENT] key together. The calibration will stop and the output stabilization time will be set up. Touch the [>] key once again to return to the basic panel display and the analyzer will be in normal measurement.

Automatic Calibration

No execution operations are required for automatic calibration. Automatic calibration starts in accordance with a preset start day and time. Calibration is then executed at preset intervals.

NOTE

Before conducting a semi-automatic or automatic calibration, run the automatic calibration unit beforehand to obtain a calibration flow of 600 ± 60 ml/min.

10. Other Functions

10.1 Detailed Display

Select the desired parameter code to display the detailed operation data (see Table 10.1, "Parameter Codes for Detailed Operation Data").

NOTE

Refer to Section 8.1, "Setting Display Item", for parameter code [A00].

Table 10.1 Parameter Codes for Detailed Operation Data

Code	Item		Engineering unit	Code	Item	Engineering unit	
A00	Selection of display items	0	Oxygen concentration		A50	Span correction ratio 0	%
		1	Oxygen analyzer (0.0)		A51	Span correction ratio 1	%
		2	Oxygen analyzer (0.0)		A52	Span correction ratio 2	%
		3	Analog output selected		A53	Span correction ratio 3	%
A01	Oxygen concentration		%O ₂	A54	Span correction ratio 4	%	
A02				A55	Span correction ratio 5	%	
A03				A56	Span correction ratio 6	%	
A04				A57	Span correction ratio 7	%	
A05				A58	Span correction ratio 8	%	
A06	Air ratio			A59	Span correction ratio 9	%	
A07	Cell temperature		°C	A60	Zero correction ratio 0	%	
A08	Cold junction temperature		°C	A61	Zero correction ratio 1	%	
A09	Meas. gas temperature		°C	A62	Zero correction ratio 2	%	
A10	Amount of water vapor in exhaust gas		%	A63	Zero correction ratio 3	%	
A11	Cell voltage		mV	A64	Zero correction ratio 4	%	
A12	TC voltage		mV	A65	Zero correction ratio 5	%	
A15	Cold junction voltage		mV	A66	Zero correction ratio 6	%	
A16	Current output		mA	A67	Zero correction ratio 7	%	
A20	Cell response time		Seconds	A68	Zero correction ratio 8	%	
A21	Cell internal resistance		Ω	A69	Zero correction ratio 9	%	
A22	Cell robustness			A70	Calibration history 0	YY.MM.DD/ HH.MM	
A23	Heater on-time ratio		%	A71	Calibration history 1	YY.MM.DD/ HH.MM	
A24	Oxygen concentration (with time constant)		%O ₂	A72	Calibration history 2	YY.MM.DD/ HH.MM	
A25				A73	Calibration history 3	YY.MM.DD/ HH.MM	
A26				A74	Calibration history 4	YY.MM.DD/ HH.MM	
A30	Maximum oxygen concentration		%O ₂	A75	Calibration history 5	YY.MM.DD/ HH.MM	
A31	Occurrence of maximum oxygen concentration		YY.MM.DD/ HH.MM	A76	Calibration history 6	YY.MM.DD/ HH.MM	
A32	Minimum oxygen concentration		%O ₂	A77	Calibration history 7	YY.MM.DD/ HH.MM	
A33	Occurrence of minimum oxygen concentration		YY.MM.DD/ HH.MM	A78	Calibration history 8	YY.MM.DD/ HH.MM	
A34	Average oxygen concentration		%O ₂	A79	Calibration history 9	YY.MM.DD/ HH.MM	
A35				A80	Time	YY.MM.DD/ HH.MM	
A36				A90	Software revision		

Note: The blank parameter codes above are not used in the oxygen analyzer.

10.1.1 Air Ratio

“Air ratio” is defined as the ratio of (the amount of air theoretically required to completely burn all the fuel) to (the amount of air actually supplied).

For this equipment, the air ratio will be obtained in a simplified way by measuring the oxygen concentration in the exhaust gas. The air ratio may be expressed mathematically by:

$$m = \frac{1}{(21 - \text{oxygen concentration})} \times 21$$

If you use the air ratio data for estimating the combustion efficiency, etc., check that no air is leaking in beforehand and that the measured value has not been affected by any interference gas (CH₄, CO, H₂, etc.).

10.1.2 Cell Temperature

This indicates the cell (sensor) temperature, usually indicating 750°C, obtainable from the thermo electromotive force and cold junction temperature described below.

10.1.3 C. J. Temperature

This is the internal (where the electronics is installed) temperature of equipment, which compensates for the cold junction temperature for a thermocouple measuring the cell temperature. If this temperature exceeds 85°C, the electronics may fail. When the ZR202 Analyzer is used, the maximum C. J. temperature will be 150°C. If the internal temperature exceeds this, take measures to reduce the temperature such as by not exposing the equipment to radiation.

10.1.4 Amount of Water Vapor in Exhaust Gas

Calculate the water vapor in the combusted exhaust gas using parameters set in Subsection 8.7.3, “Setting Fuels.” Use the following equation for calculation:

$$\begin{aligned} \text{Moisture (water vapor)} &= (\text{amount of water vapor per unit quantity of fuel}) + \\ & \quad (\text{moisture in air}) / \text{total amount of exhaust gas} \\ &= \frac{G_w + 1.61 \times Z \times A_o \times m}{X + A_o \times m} \end{aligned}$$

where,

G_w = Amount of water vapor in exhaust gas, m³/kg (or m³/m³)

Z = Atmospheric absolute humidity, kg/kg

A_o = Theoretical air amount, m³/kg (or m³/m³)

m = Air ratio

X = Fuel coefficient, Nm³/kg or m³/m³

For details on parameters, see Subsection 8.7.3, “Setting Fuels,” earlier in this manual.

10.1.5 Cell Voltage

The cell (sensor) voltage will be an index to determine the amount of degradation of the sensor. The cell voltage corresponds to the oxygen concentration currently being measured. If the indicated voltage approximates the ideal value (corresponding to the measured oxygen concentration), the sensor will be assumed to be normal.

The ideal value of the cell voltage (E), when the oxygen concentration measurement temperature is controlled at 750°C., may be expressed mathematically by:

$$E = -50.74 \log (P_x/P_a) \text{ [mV]}$$

where, P_x : Oxygen concentration in the sample gas

P_a : Oxygen concentration in the reference gas, (21 vol%O₂)

Table 10.2 shows oxygen concentration versus cell voltage.

Table 10.2 Oxygen Concentration Vs. Cell Voltage, (cell temperature: 750°C)

%O ₂	0.1	0.2	0.3	0.4	0.5	0.6	0.7	0.8	0.9
mv	117.83	102.56	93.62	87.28	82.36	78.35	74.95	72.01	69.41
%O ₂	1	2	3	4	5	6	7	8	9
mv	67.09	51.82	42.88	36.54	31.62	27.61	24.21	21.27	18.67
%O ₂	10	21.0	30	40	50	60	70	80	90
mv	16.35	0	-7.86	-14.2	-19.2	-23.1	-26.5	-29.5	-32.1
%O ₂	100								
mv	-34.4								

T10-2E.ai

10.1.6 Thermocouple Voltage

The cell temperature is measured with a Type K (chromel-alumel) thermocouple. The thermocouple cold junction is located in the detector terminal box. The cell temperature and the thermocouple voltage (including the voltage corresponding to the cold junction temperature) are displayed.

10.1.7 Cold Junction Voltage

This equipment uses temperature-measurement ICs that measure the cold junction temperatures. The voltage measured by those ICs is displayed.

10.1.8 Current Output

The analog current output is displayed.

10.1.9 Response Time

The cell's response time is obtained in the procedure shown in Figure 10.1. If only either zero or span calibration has been carried out, the response time will not be measured just as it will not be measured in manual calibration.

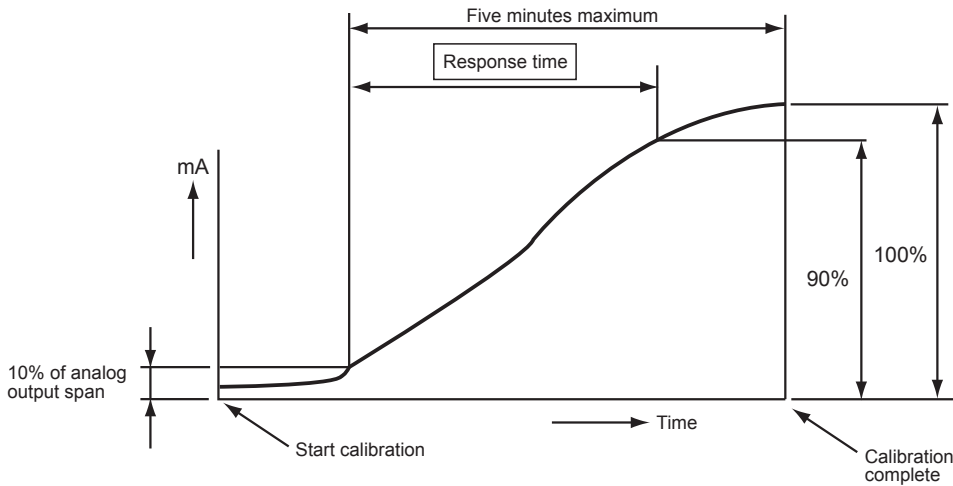

The response time is obtained after the corrected calibration curve has been found. The response time is calculated, starting at the point corresponding to 10% of the analog output up to the point at 90% of the analog output span. That is, this response time is a 10 to 90% response.

F10-1E.ai

Figure 10.1 Typical Response Time Characteristics

10.1.10 Cell's Internal Resistance

A new cell (sensor) indicates its internal resistance of 200 Ω maximum. As the cell degrades, so will the cell's internal resistance increase. The degradation of the cell cannot be found only by changes in cell's internal resistance, however. Those changes in the cell's internal resistance will be a hint to knowing the sensor is degrading. The updated values obtained during the calibration are displayed.

10.1.11 Robustness of a Cell

The robustness of a cell is an index for predicting the remaining life of a sensor and is expressed as one of four time periods during which the cell may still be used:

- (1) more than a year
- (2) more than six months
- (3) more than three months
- (4) less than one month

The above four time periods are tentative and only used for preventive maintenance, not for warranty of the performance.

This cell's robustness can be found by a total evaluation of data involving the response time, the cell's internal resistance, and calibration factor. However, if a zero or span calibration was not made, the response time cannot be measured. In such a case, the response time is not used as a factor in evaluating the cell's robustness.

Table 10.3 Cell Robustness and Service Life

Cell robustness	Cell s service life
5	One year min.
3	Six months min.
2	Three months min.
1	One month max.

10.1.12 Heater On-Time Ratio

The probe sensor is heated to and maintained at 750°C. When the sample gas temperature is high, the amount of heater ON-time decreases.

10.1.13 Oxygen Concentration (with time constant)

When the output damping is specified in the mA-output range setting, the corresponding time constant is also displayed.

10.1.14 Maximum Oxygen Concentration

The maximum oxygen concentration and the time of its occurrence during the period specified in the Averaging display are displayed. If the setup period elapses, the maximum oxygen concentration that has been displayed so far will be cleared and a new maximum oxygen concentration will be displayed. If the setup period of time is changed, the current maximum oxygen concentration will be displayed (for more details, see Subsection 8.7.2 earlier in this manual).

10.1.15 Minimum Oxygen Concentration

The minimum oxygen concentration and the time of its occurrence during the period specified in the Averaging display are displayed. If the setup period elapses, the minimum oxygen concentration that has been displayed so far will be cleared and a new minimum oxygen concentration will be displayed. If the setup period of time is changed, the current minimum oxygen concentration will be displayed (for more details, see Subsection 8.7.2 earlier in this manual).

10.1.16 Average Oxygen Concentration

The average oxygen concentration during the periods over which average values are calculated is displayed. If the setup period elapses, the average oxygen concentration that has been displayed so far will be cleared and a new average oxygen concentration will be displayed. If the setup period of time is changed, the current average oxygen concentration will be displayed (for more details, see Subsection 8.7.2 earlier in this manual).

10.1.17 Span and Zero Correction Ratios

Span and zero correction ratios for the past ten calibrations are recorded to enable you to check the degradation of the sensor (cell). If the correction ratio is beyond the limits as shown in Figure 10.2, the sensor should no longer be used.

These ratios can be found by calculating the data as shown below.

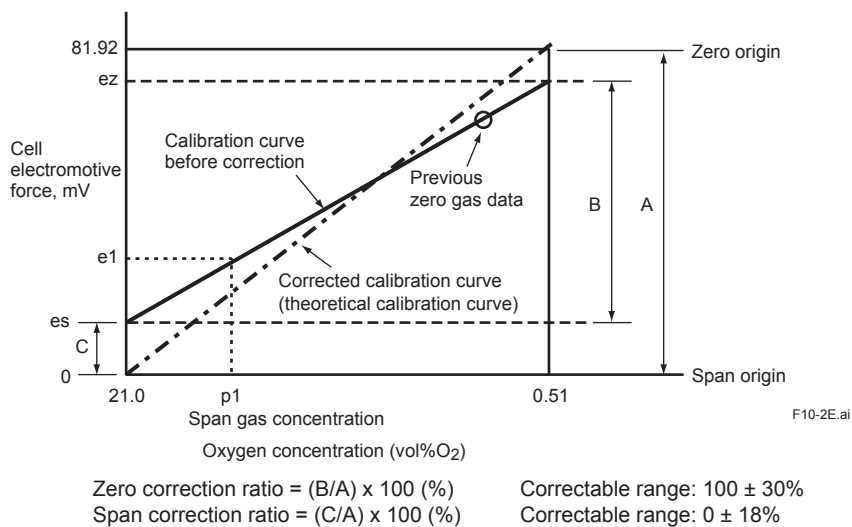

Figure 10.2 Span gas and Zero gas Correction Ratios

10.1.18 History of Calibration Time

The calibration-conducted dates and times for the past ten calibrations are stored in memory.

10.1.19 Time

The current date and time are displayed. These are backed up by built-in batteries, so no adjustment is required after the power is switched off. The following shows an example of displaying June 21, 2000, 3:06 p.m.

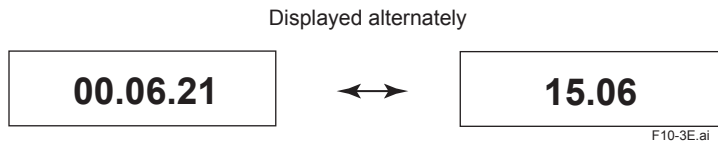

Figure 10.3 Date-and-time Display

10.1.20 Software Revision

The revision (number) of the software installed is displayed.

10.2 Operational Data Initialization

Individual set data initialization enables you to return to the default values set at the time of delivery. There are two types of initializations: an all set-data initialization and a parameter-code-based initialization. Table 10.4 lists the initialization items by a parameter code, and default values.

Table 10.4 Parameter Codes for Initialization

Parameter code	Data to be initialized
F30	All data
F31	Data in Group A
F32	Data in Group B
F33	Data in Group C
F34	Data in Group D
F35	Data in Group E
F36	Data in Group F













CAUTION

When Data in Group F are initialized by the parameter code of [F36], [F01] and [F02] and [F08] and [F10] cannot be initialized.

10.3 Initialization Procedure

Follow the table below to initialize parameters. The password for initialization is 1255.

Table 10.5 Initialization Procedure

Switch operation			Display	Description
>	^	ENT	F30	Enter the parameter code for the item to be initialized. The following show an example of entering "F30." (Previous needed operations are omitted.)
>	^	ENT 	0000	Touch the [ENT] key to switch to the password entry display.
>		ENT	1000	Enter the password 1255 for initialization.
	^	ENT	1000	
>		ENT	1200	
	^	ENT	1200	
>		ENT	1250	
	^	ENT	1250	
>		ENT	1255	
>	^	ENT 	1255	After you enter the password and then touch the [ENT] key, all the digits flash.
>	^	ENT 	USr Go	Touch the [ENT] key again to display "USr Go."
>	^	ENT 	USr Go	Touch the [ENT] key once more. All the digits then flash for two to three seconds, and data initialization starts.
>	^	ENT	F30	The initialization is complete, and the parameter code selection display then appears.

The symbol () indicates that the keys are being touched, the light characters indicates flashing.

WARNING

Do not attempt to turn off the equipment power during initialization (while "USr Go" is flashing).

10.4 Reset

Resetting enables the equipment to restart. If the equipment is reset, the power is turned off and then back on. In practical use, the power remains on, and the equipment is restarted under program control. Resetting will be possible in the following conditions:

- (1) Err-01 if the cell voltage is defective
- (2) Err-02 if a temperature alarm occurs
- (3) Err-03 if the A/D converter is defective
- (4) Err-04 if an EEPROM write error occurs

For details on error occurrence, consult Chapter 12, "Troubleshooting", later in this manual.









If any of the above problems occurs, the equipment turns off the power to the detector heater. To cancel the error, reset the equipment following the steps below, or turn the power off and then back on.

Note: Make sure that before resetting or restarting the power that there is no problem with the equipment.

CAUTION

If a problem arises again after the resetting, turn the power off and troubleshoot the problem by consulting the Troubleshooting chapter later in this manual. When there is no error, the Basic panel display will appear.

Table 10.6 **Resetting**

Switch operation			Display	Brief Description
>	^	ENT	Err-01 /-----	If an error occurs, the error number and "-----" are displayed alternately, as given on the left.
>	^	ENT 	PASSno	Hold down the [ENT] key for at least three seconds.
>	^	ENT 	0000	Touch the [ENT] key again to switch to the password entry display.
>	^ 	ENT	1000	Enter the password 1102.
Intermediate switch operations omitted.				
>	^	ENT 	1102	
>	^	ENT 	A01	
>	^ 	ENT	G01	Change the parameter code to "G30".
> 	^	ENT	G01	
>	^ 	ENT	G30	
>	^	ENT 	All the digits light up.	Touch the [ENT] key to execute resetting.

The symbol [] indicates that the corresponding keys are being touched, and the light characters indicate "flashing."

" / " indicates that the characters are displayed alternately.

 **CAUTION**

Parameters of blank item are not used for Oxygen Analyzer.

Table 10.7 Parameter Codes

Display-related Items in Group A

Code	Item		Engineering unit	Code	Item	Engineering unit	
A00	Selection of display items	0	Oxygen concentration		A50	Span correction ratio 0	%
		1	Oxygen analyzer (0.0)		A51	Span correction ratio 1	%
		2	Oxygen analyzer (0.0)		A52	Span correction ratio 2	%
		3	Analog output selected		A53	Span correction ratio 3	%
A01	Oxygen concentration		%O ₂	A54	Span correction ratio 0	%	
A02				A55	Span correction ratio 3	%	
A03				A56	Span correction ratio 2	%	
A04				A57	Span correction ratio 1	%	
A05				A58	Span correction ratio 2	%	
A06	Air ratio			A59	Span correction ratio 1	%	
A07	Cell temperature		°C	A60	Zero correction ratio 0	%	
A08	Cold junction temperature		°C	A61	Zero correction ratio 1	%	
A09	Meas. gas temperature		°C	A62	Zero correction ratio 2	%	
A10	Amount of water vapor in % exhaust gas		%	A63	Zero correction ratio 3	%	
A11	Cell voltage		mV	A64	Zero correction ratio 4	%	
A12	TC voltage		mV	A65	Zero correction ratio 5	%	
A15	Cold junction voltage		mV	A66	Zero correction ratio 6	%	
A16	Current output		mA	A67	Zero correction ratio 7	%	
A20	Cell response time		Seconds	A68	Zero correction ratio 8	%	
A21	Cell internal resistance		Ω	A69	Zero correction ratio 9	%	
A22	Cell robustness			A70	Calibration history 0	YY.MM.DD/ HH.MM	
A23	Heater on-time ratio		%	A71	Calibration history 1	YY.MM.DD/ HH.MM	
A24	Oxygen concentration (with time constant)		%O ₂	A72	Calibration history 2	YY.MM.DD/ HH.MM	
A25				A73	Calibration history 3	YY.MM.DD/ HH.MM	
A26				A74	Calibration history 4	YY.MM.DD/ HH.MM	
A30	Max. oxygen concentration		%O ₂	A75	Calibration history 5	YY.MM.DD/ HH.MM	
A31	Occurrence of maximum oxygen concentration		YY.MM.DD/ HH.MM	A76	Calibration history 6	YY.MM.DD/ HH.MM	
A32	Min. oxygen concentration		%O ₂	A77	Calibration history 7	YY.MM.DD/ HH.MM	
A33	Occurrence of minimum oxygen concentration		YY.MM.DD/ HH.MM	A78	Calibration history 8	YY.MM.DD/ HH.MM	
A34	Average oxygen concentration		%O ₂	A79	Calibration history 9	YY.MM.DD/ HH.MM	
A35				A80	Time	YY.MM.DD/ HH.MM	
A36				A90	Software revision		

Note1: “/” indicates that both are displayed alternately.

Note2: Parameter codes with no items in the above table are not used in the oxygen analyzer.

Continue to the next page

Calibration-related Items in Group B

Code	Item	Tuning	Engineering unit	Default setting
B01	Zero gas concentration	0.3 to 100	%O ₂	1%O ₂
B02	Span gas concentration	4.5 to 100	%O ₂	21%O ₂
B03	Calibration mode	0 Manual calibration		Manual calibration
		1 Semi-automatic and manual calibration		
		2 Automatic, semi-automatic, and manual calibration		
B04	Hold (Output stabilization) time	0 minutes, 0 seconds to 60 minutes, 59 seconds	MM.SS	10 minutes, 0 seconds
B05	Calibration time	0 minutes, 0 seconds to 60 minutes, 59 seconds	MM.SS	10 minutes, 0 seconds
B06	Calibration interval	0 days 0 hours to 255 days 23 hours	DD.HH	30 days, 0 hours
B07	Calibration start date and time		YY.MM.DD HH.MM	00.01.01.00.00
B08	Calibration procedure	0 Zero and span		Zero and span
		1 Span only		
		2 Zero only		
B09	Calibration concentration measurement	Display only	% O ₂	
B10	Manual calibration implementation			
B11	Semi-automatic calibration implementation			

Continue to the next page

Output-related Items in Group C

Code	Item	Tuning	Engineering unit	Default setting
C01	Analog output	0	Oxygen concentration	Oxygen concentration
		1	Amount of moisture content	
		2	Mixed ratio	
C03	Output mode	0	Linear	Linear
		1	Logarithm	
C04	Output hold during warm-up	0	4 mA	4 mA
		1	20 mA	
		2	Set value	
C05	Output hold during maintenance	0	Not held	Held output just before maintenance service
		1	Held output just before maintenance service	
		2	Set value remains held	
C06	Output hold during calibration	0	Not held	Held output just before calibration
		1	Held output just before calibration	
		2	Set value remains held	
C07	Output hold during error occurrence	0	Not held	Held output at a preset value
		1	Held output just before abnormal state occurs	
		2	Set value remains held	
C11	Min. oxygen concentration	See Section 8.2.	%O ₂	0%O ₂
C12	Max. oxygen concentration	See Section 8.2.	%O ₂	25%O ₂
C30	Output damping constant	0 to 255	Seconds	0 second
C31	Set value during warm-up	2.4 to 21.6	mA	4 mA
C32	Set value during maintenance	2.4 to 21.6	mA	4 mA
C33	Set value during calibration	2.4 to 21.6	mA	4 mA
C34	Set value in abnormal state	2.4 to 21.6	mA	3.4 mA

Note: "C07" and "C34" is not displayed when option code "/C2" or "/C3" (NAMUR NE 43 compliant) is specified.

Alarm-related Items in Group D

Code	Item	Tuning	Engineering unit	Default setting
D01	Oxygen concentration high-high alarm setpoint	0 to 100	%O ₂	100%O ₂
D02	Oxygen concentration high alarm setpoint	0 to 100	%O ₂	100%O ₂
D03	Oxygen concentration low alarm setpoint	0 to 100	%O ₂	0%O ₂
D04	Oxygen concentration low-low alarm setpoint	0 to 100	%O ₂	0%O ₂
D30	Oxygen concentration alarm hysteresis	0 to 9.9	%O ₂	0.1%O ₂
D33	Delayed alarm action	0 to 255	Seconds	3 seconds
D41	Oxygen concentration high-high alarm detection	0	Not detected	Not detected
		1	Detected	
D42	Oxygen concentration high alarm detection	0	Not detected	Not detected
		1	Detected	
D43	Oxygen concentration low alarm detection	0	Not detected	Not detected
		1	Detected	
D44	Oxygen concentration low-low alarm detection	0	Not detected	Not detected
		1	Detected	

Continue to the next page

Contact-related Items in Group E

Code	Item	Tuning		Engineering unit	Default setting
E01	Selection of contact input 1	0	Invalid		Invalid
		1	Calibration gas pressure decrease		
		2	Measurement range change		
		3	Calibration start		
		4	Detection of non-combusted gas		
E02	Selection of contact input 2	0	Invalid		Invalid
		1	Calibration gas pressure decrease		
		2	Measurement range change		
		3	Calibration start		
		4	Detection of non-combusted gas		
E03	Selecting action of contact input 1	0	Action with closed contact		Action with closed contact
		1	Action with open contact		
E04	Selecting action of contact input 2	0	Action with closed contact		Action with closed contact
		1	Action with open contact		
E10	Selecting action of contact output 1	0	Action with closed contact (normally de-energized)		Action with closed contact
		1	Action with open contact (normally energized)		
E20	Contact output 1 error	0	No action		No action
		1	Action		
E21	Contact output 1, high-high alarm	0	No action		No action
		1	Action		
E22	Contact output 1, high alarm	0	No action		No action
		1	Action		
E23	Contact output 1, low alarm	0	No action		No action
		1	Action		
E24	Contact output 1, low-low alarm	0	No action		No action
		1	Action		
E25	Contact output 1, during maintenance	0	No action		Action
		1	Action		
E26	Contact output 1, during calibration	0	No action		No action
		1	Action		
E27	Contact output 1, measurement range change	0	No action		No action
		1	Action		
E28	Contact output 1, during warm-up	0	No action		Action
		1	Action		
E29	Contact output 1, calibration gas pressure decrease	0	No action		No action
		1	Action		
E32	Contact output 1, detection of non-combusted gas	0	No action		No action
		1	Action		

Continue to the next page

Equipment Setup and Others in Group F

Code	Item	Tuning	Engineering unit	Default setting
F01	Equipment setup	0	Oxygen analyzer	Oxygen analyzer
		1	Humidity analyzer	
F02	Selection of measurement gas	0	Wet	Wet
		1	Dry	
F04	Selection of temperature units	0	degree C	degree C
		1	degree F	
F05	Selection of pressure units	0	kPa	kPa
		1	psi	
F08	Selection of display items	0	Oxygen concentration	Oxygen concentration
		1	Amount of moisture quantity	
		2	Mixed ratio	
		3	Item selected with analog output	
F10	Date		YY.MM.DD/ HH.MM	
F11	Period over which average values are calculated	1 to 255 hours	Hours	One hour
F12	Period over which max. and min. values are monitored	1 to 255 hours	Hours	24 hours
F20	Amount of water vapor in exhaust gas	0 to 5	m ³ /kg (m ³)	1.0 m ³ /kg (m ³)
F21	Theoretical amount of air	0 to 20	m ³ /kg (m ³)	1.0 m ³ /kg (m ³)
F22	X value	0 to 19.99		1.0
F23	Absolute humidity of the atmosphere	0 to 1	kg/kg	0.1 kg/kg
F30	Initializing all data			
F31	Initializing data in group A			
F32	Initializing data in group B			
F33	Initializing data in group C			
F34	Initializing data in group D			
F35	Initializing data in group E			
F36	Initializing data in group F			

Inspection-related Items in Group G

Code	Item	Tuning	Engineering unit	Default setting
G01	mA-output loop	4 to 20	mA	4 mA
G11	Contact output 1	0	Open	Open
		1	Closed	
G12	Contact output 2	0	Open	Open
		1	Closed	
G15	Calibration contact output (zero)	0	Off	Off
		1	On	
G16	Calibration contact output (span)	0	Off	Off
		1	On	
G21	Contact input 1	0	Open	
		1	Closed	
G22	Contact input 2	0	Open	
		1	Closed	
G30	Reset			

10.5 Handling of the ZO21S Standard Gas Unit

WARNING

Use only non-hazardous area.

The following describes how to flow zero and span gases using the ZO21S Standard Gas Unit. Operate the ZO21S Standard Gas Unit, for calibrating a system classified as System 1, according to the procedures that follow.

10.5.1 Standard Gas Unit Component Identification

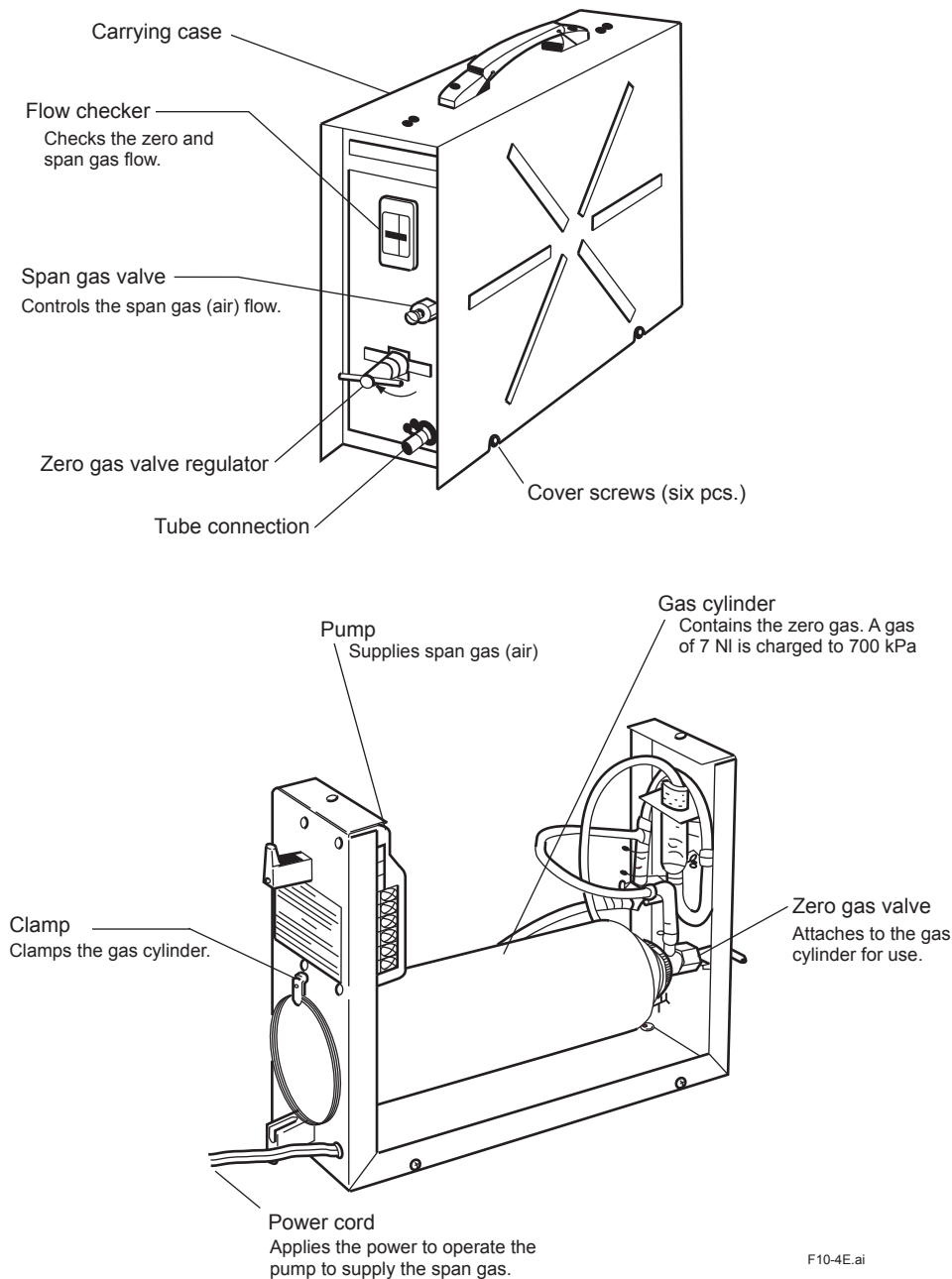

Figure 10.4 Standard Gas Unit Component Identification

10.5.2 Installing Gas Cylinders

Each ZO21S Standard Gas Unit comes with six zero gas cylinders including a spare. Each gas cylinder contains 7-liters of gas with a 0.95 to 1.0 vol%O₂ (concentration varies with each cylinder) and nitrogen, at a pressure of 700 kPaG (at 35°C).

The operating details and handling precautions are also printed on the product. Please read them beforehand.

To install the gas cylinder, follow these steps:

- (1) Attach the zero gas valves onto the gas cylinder. First, turn the valve regulator of the zero gas valves counterclockwise to completely retract the needle at the top from the gasket surface. Maintaining the valve in this position, screw the valve mounting into the mouthpiece of the gas cylinder. (If screw connection is proper, you can turn the screw manually. Do not use any tool.) When the gasket comes in contact with the mouthpiece of the gas cylinder and you can no longer turn it manually, tighten the lock nut with a wrench.
- (2) Remove the carrying case from the standard gas unit. The case is attached to the unit with six screws. So, loosen the screws and lift them off.
- (3) Slide the gas cylinder through the hole in the back of the unit and connect the tube (the piping in the unit) to the valve connections. Insert each tube at least 10 mm to prevent leakage, and secure it using a tube clamp.
- (4) Attach the gas cylinder to the case. Extend the valve regulator of the zero gas valves through the hole in the front panel of the unit and secure the bottom of the cylinder with the clamp.
- (5) Take note of the oxygen concentration of the sealed gas indicated on the gas cylinder and replace the carrying case. Enter the oxygen concentration of the sealed gas using the parameter code B01 as a zero gas oxygen concentration. Also check that no piping is disconnected.

Thus, the work of installing a gas cylinder is completed. However, gases in the cylinders cannot immediately flow out after these procedures. To discharge the gases, it is necessary for the needle in the zero gas valves to puncture a hole in the gas cylinder.

For this operation, see Subsection 10.5.3.

10.5.3 Calibration Gas Flow

<Preparation before calibration>

- (1) To operate the standard gas unit, place it on a nearly horizontal surface in order to allow the flow check to indicate the precise flow rate. In addition, a power supply for driving the span gas (air) supply pump is required near the unit (the length of the power cord attached to the unit is 2 m). Select a suitable location for the unit near the installation site of the analyzer.
- (2) Connect the tube connector port of the standard gas unit to the calibration gas inlet of the analyzer, using a polyethylene resin tube with an outside diameter of 6 mm. Be careful to prevent gas leakage.
- (3) Fully open the stop valve mounted on the calibration gas inlet of the analyzer.
- (4) Enter the oxygen concentration of the sealed gas (noted from the cylinder) into the analyzer. Also check that the oxygen concentration of the span gas is correctly set (21 vol%O₂ for clean air). When using the ZO21S Standard Gas Unit (for use of the atmospheric air as a span gas), use a hand-held oxygen analyzer to measure the actual oxygen concentration, and then enter it.

<Flow of span gas (air)>

The standard gas unit is used only when manual calibration is employed.

Therefore, the timing for flowing span gas (air) is included in the manual calibration flowchart described in Subsection 7.10.2, earlier in this manual. For operation of the analyzer, see Subsection 7.10.2.

- (1) When the "OPEn" and the "measured oxygen concentration" are alternately displayed during calibration, plug the power cord into the power supply socket to start the pump of the standard gas unit.
- (2) Next, adjust the flow rate to 600 ± 60 ml/min using the span gas valve "AIR" (the flow check ball stops floating on the green line when the valve is slowly opened). To rotate the valve shaft, loosen the lock nut and turn it using a flat-blade screwdriver. Turning the valve shaft counterclockwise increases the flow rate.
- (3) After adjusting the flow rate, tighten the valve lock nut.
- (4) After the measured oxygen concentration is stabilized, touch the [ENT] key, then all the digits flash. Touch the [ENT] key again to display "ZEro Y". Disconnect the power cord to stop the pump.

<Flow of zero gas>

Touch the [ENT] key to display a zero gas value set with the parameter code B01. Touch the [ENT] key again to flash "OPEn" and the "measured oxygen concentration" alternately. To cause the zero gas flow, follow these steps:

- (1) Use the needle of the zero gas valve "CHECK GAS" to puncture a hole in the gas cylinder installed as described in Subsection 10.5.2. Fully clockwise turn the valve regulator by hand.
- (2) Next, adjust the flow rate to 600 ± 60 ml/min (the flow check ball stops floating on the green line when the valve is slowly opened). Turn the regulator of the zero gas valve back slowly counterclockwise. At that time, the flow rate also decreases as the inner pressure of the gas cylinder decreases. Monitor the flow check and, when the ball's position changes greatly, readjust the valve.
- (3) Touch the [ENT] key after the measured oxygen concentration becomes stable. Then all the digits flash. Touch the [ENT] key again so that the "CALEnd" flashes.

NOTE

Be sure not to terminate the calibration in progress because of a shortage of gas in the cylinder. Each gas cylinder is operable for nine minutes or more provided the gas is discharged at the specified rate.

Therefore, if your calibration time is estimated at four minutes, you can operate the zero calibration twice.

- (4) Stop the zero gas flow. Turn the zero gas valve regulator fully clockwise. If this valve regulator is not properly adjusted, the needle valve will not close completely and a cylinder gas may leak. When the output stabilization time elapses, the calibration is complete.

<Treatment after completion of calibration>

- (1) Fully close the stop valve mounted on the calibration gas inlet of the detector.
- (2) Remove the tube connecting the detector to the standard gas unit.

 **WARNING**

Store the standard gas unit with the gas cylinder mounted where the ambient temperature does not exceed 40°C. Otherwise, the gas cylinder may explode. Store the spare gas cylinders under the same condition.

10.6 Methods of Operating Valves in the ZA8F Flow Setting Unit

The ZA8F Flow Setting Unit is used as the calibration equipment for a system conforming to System 2. Calibration in such a system is to be manually operated. So, you have to operate the valve of the Flow Setting Unit each time calibration is made (starting and stopping the calibration gas flow and adjusting the flow rate).

10.6.1 Preparation Before Calibration

To operate the ZA8F Flow Setting Unit, prepare for calibration as follows:

- (1) Check for a complete closing of the zero gas flow setting valve in the unit and open the reducing valve for the zero gas cylinder until the secondary pressure is [measurement gas pressure plus approx. 50 kPa, measurement gas pressure plus approx. 150 kPa when a check valve is used] (300 kPa maximum).
- (2) Check that the oxygen concentration of the zero gas and span gas (instrument air 21 vol%O₂) in the cylinder is set for the analyzer.

10.6.2 Operating the Span Gas Flow Setting Valve

The following description is given assuming that instrument air, the same as the reference gas, is used as the span gas. For more details, see Subsection 7.10.2, "Manual Calibration," earlier in this manual.

- (1) When "OPEn" and the "measured oxygen concentration" appear alternately during the span calibration, open the span gas flow setting valve of the flow setting unit and adjust the flow rate to 600 ± 60 ml/min.
Loosen the lock nut if the valve shaft has a lock nut, and turn the valve regulator slowly counterclockwise. To check the flow rate, use the calibration flowmeter.
- (2) Adjust the flow rate. After the measured oxygen concentration has stabilized, touch the [ENT] key, then all the digits will flash. Touch the [ENT] key again to display "ZEro Y."
- (3) Close the span gas flow setting valve to stop the span gas (air) flow. If the valve shaft has a lock nut, be sure to tighten the lock nut to prevent any leakage of the span gas into the sensor during measurement.

10.6.3 Operating the Zero Gas Flow Setting Valve

Operate the zero gas flow setting valve during zero calibration in the following procedures:

- (1) When the "OPEn" and the "measured oxygen concentration" appear alternately during calibration, open the zero gas flow setting valve of the flow setting unit and adjust the flow rate to 600 ± 60 ml/min. To rotate the valve shaft, loosen the lock nut if the valve shaft has a lock nut and slowly turn it counterclockwise.
- (2) To check the flow rate, use an appropriate calibration gas flowmeter.
- (3) Adjust the flow rate. After the measured oxygen concentration is stabilized, touch the [ENT] key, then all the digits will flash. Touch the [ENT] key again to flash "CAL End."
- (4) Close the zero gas flow setting valve to stop the zero gas flow. Be sure to tighten the lock nut if the valve shaft has a lock nut to prevent any leakage of zero gas into the sensor during measurement. When the stabilization time elapses, the zero calibration will be complete.

10.6.4 Treatment After Calibration

No special treatment of the instrument is needed after calibration. However, it is recommended that the pressure reducing valve for the zero gas cylinders be closed because calibration is not required so often.

11. Inspection and Maintenance

This chapter describes the inspection and maintenance procedures for the EXAxt ZR Zirconia Oxygen Analyzer to maintain its measuring performance and normal operating conditions.

WARNING

When checking the detector, carefully observe the following:

- The instrument modification or parts replacement by other than authorized representative of Yokogawa Electric Corporation is prohibited and will void ATEX Flameproof approval, Factory Mutual Explosion-proof approval and Canadian Standards Explosion-proof certification.
 - Do NOT touch the probe if it has been in operation immediately just before being checked. (The sensor at the tip of the probe heats up to 750°C during operation. If you touch it, you will get burned.)
-

CAUTION

- Do not subject the probe to shock or cool it rapidly. The sensor is made of ceramic (zirconia). If the detector is dropped or bumped into something, the sensor may be damaged and no longer work.
 - Do not reuse a metal O-ring to seal the cell assembly. If you replace the cell or remove it from the probe for checking, be sure to replace the metal O-ring. Otherwise, the furnace gas may leak, and then the leaking corrosive gas will cause the built-in heater or thermocouple to disconnect, or the detector may corrode.
 - Before opening or closing the terminal box, first remove dust, sand, or the like from the terminal box cover.
-

11.1 Inspection and Maintenance of the Detector

11.1.1 Cleaning the Calibration Gas Tube

The calibration gas, supplied through the calibration gas inlet of the terminal box into the detector, flows through the tube and comes out at the tip of the probe. The tube might become clogged with dust from the sample gas. If you become aware of clogging, such as when a higher pressure is required to achieve a specified flow rate, clean the calibration gas tube.

To clean the tube, follow these steps:

- (1) Remove the detector from the installation assembly.
Remove the Flame Arrestor Assembly following Subsection 11.1.4.
- (2) Following Subsection 11.1.2, later in this manual, remove the four bolts (and associated spring washers) that tighten the sensor assembly, and the pipe support as well as the U-shaped pipe with filter .
- (3) Use a rod 2 to 2.5 mm in diameter to clean the calibration gas tube inside the probe. In doing this, keep air flowing from the calibration gas inlet at about 600 ml/min and insert the rod into the tube (3-mm inside diameter).
However, be careful not to insert the rod deeper than 40 cm.
- (4) Clean the U-shaped pipe. The pipe can be rinsed with water. However, it should be dried out thoroughly before reassembly.
- (5) Restore all components you removed for cleaning. Follow Subsection 11.1.2 to restore all components in their original positions. Be sure to replace the O-ring(s) with new ones.

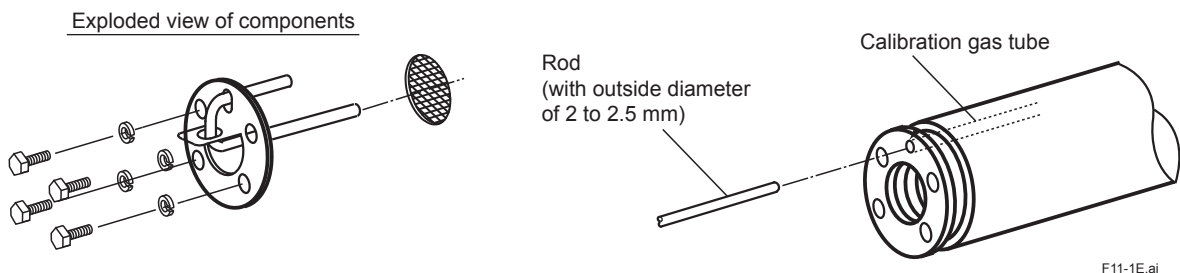

Figure 11.1 Cleaning the Calibration Gas Tube

11.1.2 Replacing the Sensor Assembly

The performance of the sensor (cell) deteriorates as its surface becomes soiled during operation. Therefore, you have to replace the sensor when its life expectancy expires, for example, when it can no longer satisfy a zero correction ratio of $100\pm 30\%$ or a span correction ratio of $0\pm 18\%$. In addition, the sensor assembly is to be replaced if it becomes damaged and can no longer operate during measurement.

If the sensor becomes no longer operable (for example, due to breakage), investigate the cause and remedy the problem as much as possible to prevent recurrence.

CAUTION

- If the sensor assembly is to be replaced, allow enough time for the detector to cool down from its high temperature. Otherwise, you may get burned.
- If the cell assembly is to be replaced, be sure to replace the metal O-ring and the contact together. Additionally, even in a case where the cell is not replaced, if the contact becomes deformed and cannot make complete contact with the cell, replace the contact.
- If there is any corroded or discolored area in the metal O-ring groove in which the contact is embedded, sand the groove with sandpaper or use a metal brush, and then sand further with a higher grade of sandpaper (No. 1500 or so), or use an appropriate metal brush to eliminate any sharp protrusions on the groove. The contact's resistance should be minimized.
- Use cell assemblies manufactured in or after Sept. 2000: the serial number on the side of the cell assembly should be 0J000 or later (for example: 0K123, 1AA01 etc.)

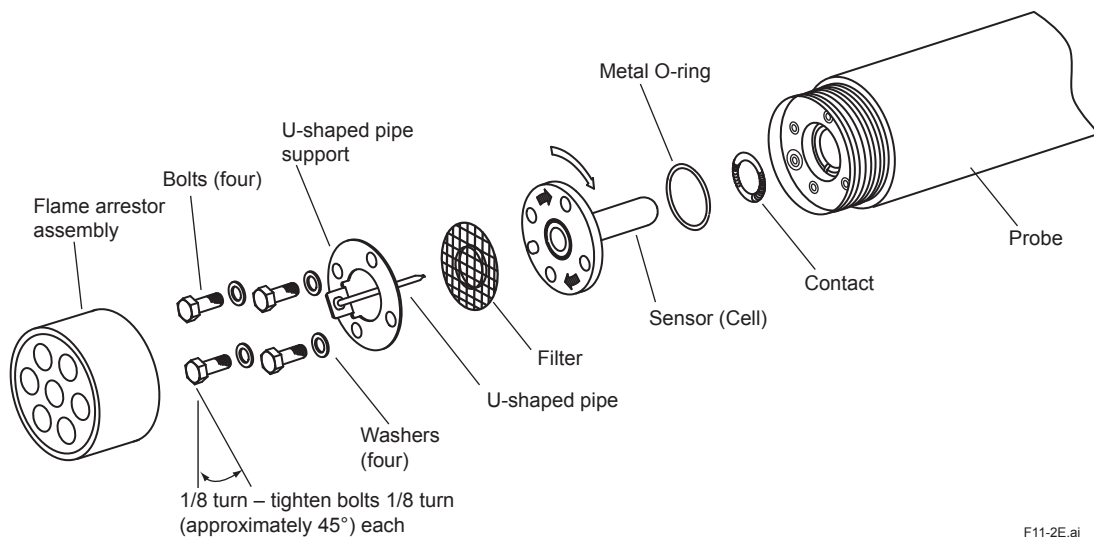

Figure 11.2 Exploded View of Sensor Assembly

CAUTION

Optional Inconel bolts have a high coefficient of expansion. If excess torque is applied while the bolts are being tightened, abnormal strain or bolt breakage may result. So, tighten the bolts following the instructions given above.

1. Identifying parts to be replaced

In order not to lose or damage disassembled parts, identify the parts to be replaced from among all the parts in the sensor assembly. Normally, replace the sensor (cell), metal O-ring and contact together at the same time. If required, also replace the U-shaped pipe, bolts, filter and associated spring washers.

2. Removal procedures

- (1) Remove the flame arrester assembly using a special pin spanner (P/N: K9471UX).
- (2) Remove the four bolts and associated washers from the tip of the detector probe.
- (3) Remove the U-shaped pipe support together with the U-shaped pipe. Remove the filter also.
- (4) Pull the sensor assembly toward you while turning it clockwise. Also, remove the metal O-ring between the assembly and the probe. (When replacing the assembly, be careful not to allow any flaws on the tip of the probe with which the metal O-ring comes in contact (the surface with which the sensor flange also comes in contact. Otherwise, the sample gas will not be sealed.)
- (5) Use tweezers to pull the contact out of the groove.
- (6) Clean the sensor assembly, especially the metal O-ring contact surface to remove any contaminants adhering to that part. If you can use any of the parts from among those removed, also clean them up to remove any contaminants adhering to them. (Once the metal O-ring has been tightened, it can no longer be used. So, be sure to replace it.)

3. Part assembly procedure

- (1) First, install the contact. Being careful not to cause irregularities in the pitch of the coil spirals (i.e., not to bend the coil out of shape), place it in the ringed groove properly so that it forms a solid contact.

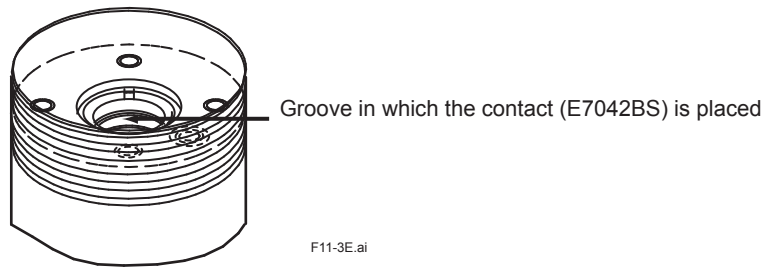

Figure 11.3 Installing the Contact

- (2) Next, make sure that the O-ring groove on the flange surface of the sensor (cell) is clean. Install the metal O-ring in that O-ring groove, and then insert the sensor (cell) in the probe while turning it clockwise. After inserting it until the metal O-ring comes in contact with the probe's O-ring contact surface, properly align the U-shaped-pipe insertion holes with the bolt openings.
- (3) Attach the U-shaped pipe to its support, then fully insert the U-shaped pipe, filter and its support into the probe.
- (4) Coat the threads of the four bolts with anti-seize grease and then screw them in along with the washers. First, tighten the four bolts uniformly by hand, and then use a torque wrench to tighten all areas of the metal O-ring uniformly, that is, to make sure the sensor flange is perfectly horizontal to the O-ring's working face in the probe. This is done by tightening first one bolt and then its opposing bolt each 1/8 turn, and then one of the other bolts followed by its opposing bolt, each also 1/8 turn.
This continues in rotating fashion until they are all fully tightened with the torque wrench preset to approximately 5.9 N•m. If they are not uniformly tightened, the sensor or heater may be damaged.
Replacement of the sensor assembly is now complete. Attach and fix the flame arrestor assembly. Install the detector and restart operation. Calibrate the instrument before making a measurement.

11.1.3 Replacement of the Heater Assembly

This subsection describes the replacement procedure for the heater assembly.

The sensor or ceramic heater-furnace core internal structure is subject to fracturing, so do NOT subject it to strong vibrations or shock. Additionally, the heater assembly reaches high temperatures and is subjected to high voltages.

So, maintenance services should be performed after the power is off and the heater assembly temperature has returned to normal room temperature.

For details, refer to IM11M12A01-21E "Heater Assembly".

NOTE

If the heater strut assembly cannot be removed because a screw has fused to its thread, one of our service representatives can fix it.

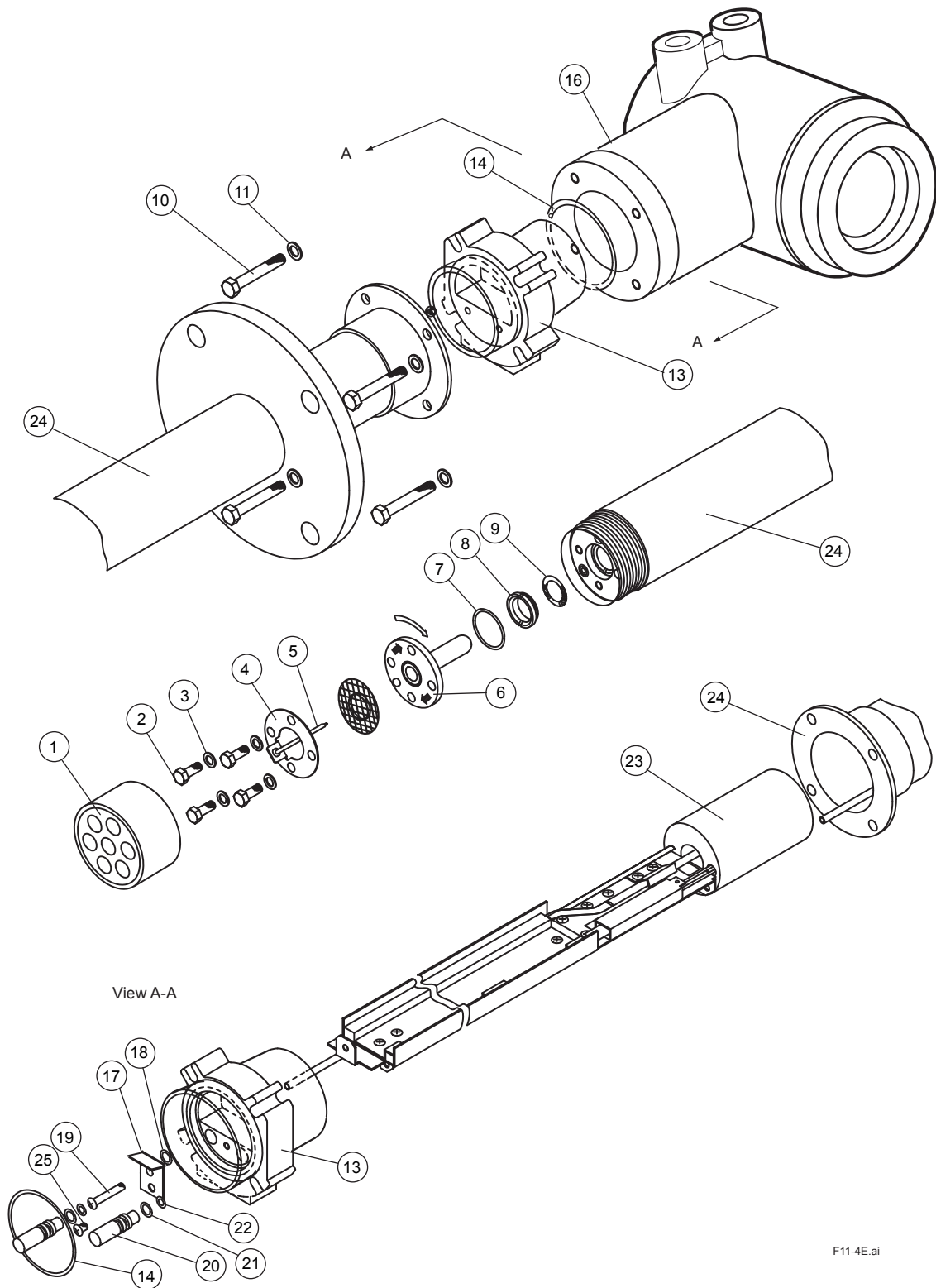

Figure 11.4 Exploded View of Detector

F11-4E.ai

Replacement of heater strut assembly

Refer to Figure 11.4 as an aid in the following discussion.

Remove the sensor assembly, following Subsection 11.1.2, earlier in this manual.

Remove the four bolts ⑩ to remove the converter ⑩. Then remove the three connectors to which lead wire from the heater and thermocouple is connected.

Loosen screw ⑲ until it can be removed from hole in heater strut assembly ⑳ plate.

O-ring ⑱ prevents screw ⑲ from dropping out. The O-ring does not loosen and remove the screw for the heater assembly fixation ⑧ with a special wrench (part no. K9470BX or equivalent) and then remove the heater strut assembly ⑳ from the detector ㉔ .

To reassemble the heater strut assembly, reverse the above procedure:

Insert the heater strut assembly ⑳ into the detector ㉔ , while inserting the calibration pipe in the detector ㉔ into the heater section in the heater strut assembly ⑳ as well as in the bracket hole. Coat the screw for the heater assembly fixation ⑧ with grease (NEVER-SEEZ: G7067ZA) and tighten the screw for the heater assembly fixation ⑧ with a special wrench (part no. K9470BX or equivalent) with a tightening torque of $12\text{N}\cdot\text{m} \pm 10\%$.

Next, to install the O-rings ㉒ on the calibration gas and reference gas pipes, disassemble the connector ⑬ in the following procedure:

First, remove the screw ㉕ and then remove the plate ⑰ and two caps ㉖ . If the O-ring ㉒ remains in the hole, pull them out from the back. Pass the heater and thermocouple lead wire through the connector ⑬. Also, pass the calibration-gas and reference-gas pipes through the opening of the connector ⑬. If the O-ring ㉒ fails, replace it with a new one.

Push the two caps ㉖ into the associated opening of the connector ⑬ . Insert the plate ⑰ , aligning it with the groove of the cap ㉖ , and tighten it with the screw ㉕ . If you attempt to insert the calibration gas and reference gas pipes into the connector ⑬ without disassembling the connector ⑬ , the O-ring may be damaged. Tighten screw ⑲ to the plate ⑰ of heater strut assembly until connector ⑬ can't move.

When installing the cell assembly ⑥ , replace the metal O-ring ⑦ with a new one.

11.1.4 Replacement of Flame Arrestor Assembly

If it takes longer for the analyzer to return to read the concentration of a sample gas after calibration, the flame arrestor may have become clogged. Inspect the flame arrestor and if necessary, clean or replace it.

Set the flame arrestor assembly ① in place using a special pin spanner (with a pin 4.5 mm in diameter: part no. K9471UX or equivalent). If a flame arrestor assembly that has already been replaced once is used again, apply grease (NEVER-SEEZ: G7067ZA) to the threads of the flame arrestor assembly.

If the flame arrestor assembly is clogged with dust, replace it with new one or wash it.

In case of the ATEX flameproof model (MS Code: ZR202S-A-...) or IECEx flameproof model (MS Code: ZR202S-D-...), the flame arrestor assembly ① is bonded to the detector ㉔ with an ceramic adhesive. To remove the flame arrestor assembly ① , crack the hardened adhesive on the joint by tapping it with a flat head screwdriver and a hammer or appropriate tools. After reattaching the flame arrestor assembly ① , apply a small amount of ceramic adhesive (part no. G7018ZA), with a diameter not exceeding 10 mm, to the joint part. Be careful not to allow the ceramic adhesive to enter between the female and the male screws. Before applying, stir the ceramic adhesive thoroughly. The ceramic adhesive should be stored in a cool, dark place and has a shelf life of 6 months from the date of shipment.

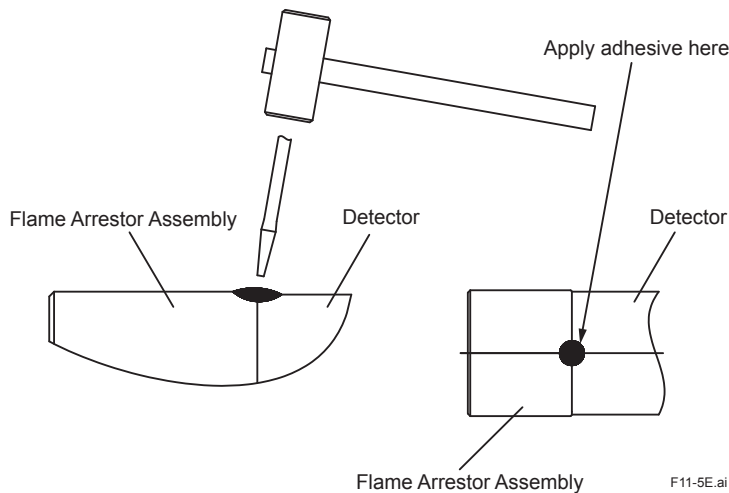

Figure 11.5 Removal of Flame Arrestor

11.1.5 Replacement of O-ring

The detector uses three different types of O-rings (14), (21), and (22). Two O-ring of each type.

11.1.6 Stopping and Re-starting Operation

<Stopping Operation>

When operation is stopped, take care of the followings so that the sensor of the detector cannot become unused.

CAUTION

When operating an instrument such as boiler or industrial furnace is stopped with the zirconia oxygen analyzer operation, moisture can condensate on the sensor portion and dusts may stick to it.

If operation is restarted in this condition, the sensor which is heated up to 750°C may become permanently contaminated. Consequently, the dusts can make the sensor performance very lower. If a large amount of water is condensed, the sensor can be broken and never be used.

To prevent the above nonconformity, take the following action when stopping operation.

- (1) If possible, keep on supplying the power to converter and flowing reference gas to the sensor.
If impossible to do the above, remove the detector.
- (2) If unavoidably impossible to supply the power and removing the detector, keep on flowing air at 600 ml/min into the calibration gas pipe.

<Restarting Operation>

When restarting operation, be sure to flow air, for 5-10 minutes, at 600 ml/min into the calibration gas pipe before supplying the power to converter.

11.2 Inspection and Maintenance of the Analyzer

The converter does not require routine inspection and maintenance. If the converter does not work properly, in most cases it probably comes from problems or other causes.

■ Replacing Fuses

This equipment incorporates a fuse. If the fuse blows out, turn off the equipment power and replace it in the following procedure.

CAUTION

If a replaced fuse blows out immediately, there may be a problem in the circuit. Check the circuit carefully to find out why the fuse has blown.

Before removing the electronics, touch the grounded metal part to discharge any static electricity.

- (1) Remove the display cover (Figure 11.6).
- (2) Remove the three screws that are located toward you, among the four screws shown in Figure 11.7. Loosen the remaining one.
- (3) Move the electronics up to remove it.

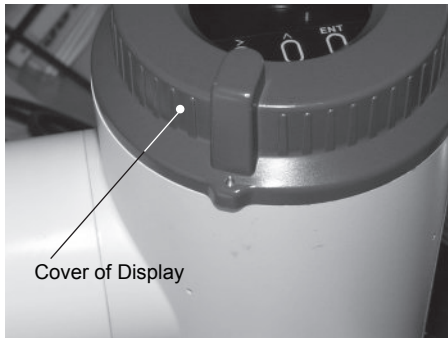

F11-6E.ai

Figure 11.6 Cover of Display

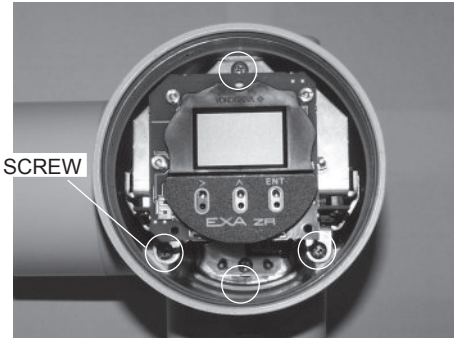

F11-7E.ai

Figure 11.7 Location of Screw

- (4) Disconnect the three connectors from the printed-circuit board, as shown in Figure 11.8, by holding the connector housing. Do not pull the lead wire out to remove the connectors, otherwise, disconnection may result.
- (5) Remove the electronics completely to gain access to the fuse on the bottom of the equipment case (Figure 11.9).
- (6) Replace the fuse with a new one.

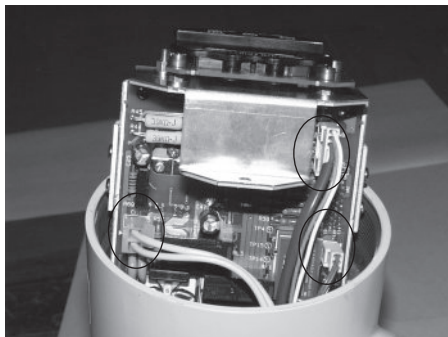

F11-8E.ai

Figure 11.8 Locations of Connectors

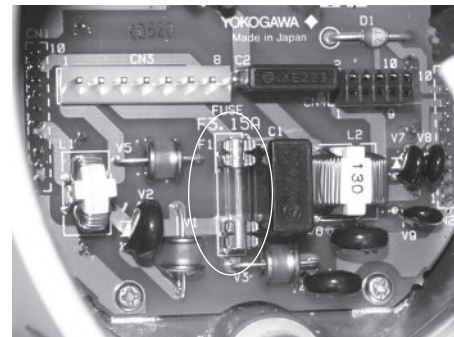

F11-9E.ai

Figure 11.9 Location of Fuse

- (7) To restore the electronics, reverse the above removal procedures.
When restoring the electronics, do not get lead wire jammed in any part of the unit.
- (8) Place the electronics and the printed-circuit board on which the fuse is installed properly; these are directly connected with connectors.
- (9) Tighten the four screws in their positions.
- (10) Replace and tighten the display cover properly. If the cover is not tightened sufficiently, the infrared switches will not operate correctly.

■ Fuse rating

Check the rating of the fuse and that it satisfies the following :

Maximum rated voltage : 250 V

Maximum rated current : 3.15 A

Type : Time-lag fuse

Standards : UL-, CSA- and VDE-approved

Part number : A1113EF

11.3 Replacement of Flowmeter for Automatic Calibration Unit

- (1) Remove pipe holding piping fitting
- (2) Remove bolts holding flowmeter, and replace it. A white back plate (to make the float easy to see) is attached. The end of the pin holding down the back plate must be on the bracket side.
- (3) Replace piping, and fix M6 bolts between brackets. *1

*1 : When disassembling and reassembling, mark original positions, and tighten an extra 5-10° when reassembling.
After tightening, do a liquid leakage test.

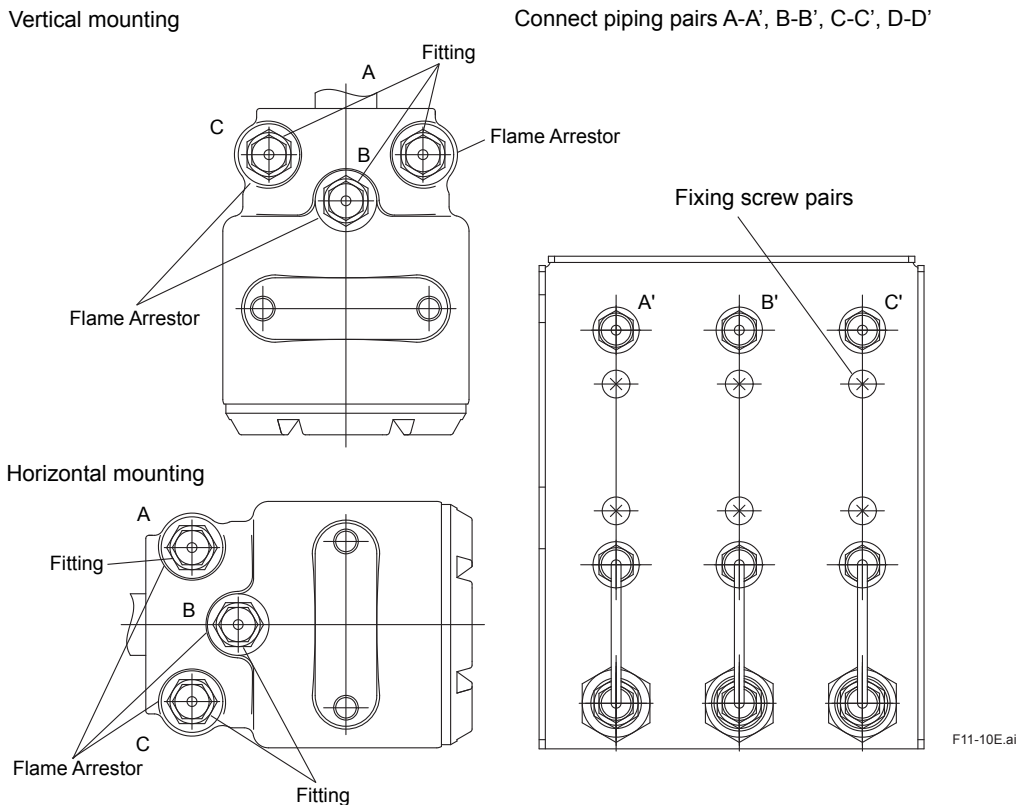

Figure 11.10 Fixing Flowmeter

WARNING

Do not loosen or remove any Flame Arrestor of gas inlet/outlet during piping.
The detector modification or parts replacement by other than authorized representative of Yokogawa Electric Corporation is prohibited and will void ATEX Flameproof Certification, FM Explosion-proof Approval and CSA Explosion-proof Certification.

12. Troubleshooting

This chapter describes errors and alarms detected by the self-diagnostic function of the converter. It also describes the check and remedies when problems other than the above occur.

12.1 Displays and Remedies When Errors Occur

12.1.1 Error Types

An error is detected if any abnormality is generated in the detector or the converter, e.g., in the cell (sensor) or heater in the detector, or the internal circuits in the converter. If an error occurs, the analyzer performs the following:

- (1) Stops the supply of power to the heater in the detector to insure system safety.
- (2) Causes an error indication in the display to start blinking to notify of an error generation (Figure 12.1).
- (3) Sends a contact output if the error (Parameter code E20) is set up for “Contact output setting” for that contact (refer to Section 8.5, “Contact Output Setting”).
- (4) Changes the analog output status to the one set in “Output hold setting” (refer to Section 8.3, “Output Hold Setting”).

The content of errors that are displayed include those shown in Table 12.1.

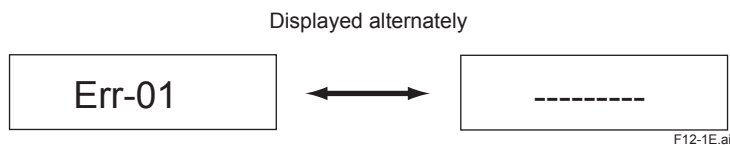

Figure 12.1

Table 12.1 **Types of Errors and Reasons for Occurrence**

Error No.	Type of error	Reason for Occurrence
Err-01	Cell voltage failure	The cell (sensor) voltage signal input to the converter falls below -50 mV.
Err-02	Heater temperature failure	The heater temperature does not rise during warm-up, or it falls below 730°C or exceeds 780°C after warm-up is completed.
Err-03	A/D converter failure	The A/D converter fails in the internal electrical circuit in the converter.
Err-04	Memory failure	Data properly are not written into memory in the internal electrical circuit in the converter.

12.1.2 Remedies When an Error Occurs

Err-01: Cell Voltage Failure

Err-01 occurs when the cell (sensor) voltage input to the converter falls below -50 mV (corresponding to about 200 vol%O₂). The following are considered to be the causes for the cell voltage falling below -50 mV:

- (1) Continuity failure between the sensor assembly electrode and the contact.
- (2) Damage or deterioration of the sensor assembly.
- (3) Improper connection between the sensor and the electronics.
- (4) Wiring failure inside the detector.
- (5) Abnormality in electrical circuits inside the converter.

<Locating cause of failure, and countermeasures>

- (1) Turn off the power to the equipment.
- (2) Remove the sensor assembly from the probe. Check for dirty or corroded sensor parts, including electrode and contact.
- (3) If the contact part is normal, the sensor assembly may be damaged or deteriorated. Replace the sensor assembly. In this case, be sure to replace the metal O-ring and contact.
- (4) If Err-01 still occurs, check that the sensor and the electronics are properly connected.
- (5) Remove the probe to gain access to the two connectors (four connectors for the optional automatic calibration unit), as indicated in Figure 12.2. Check these connectors are properly connected.
- (6) If Err-01 still occurs, the electronics may be defective. Contact your local Yokogawa service or sales representative.

Err-02: Heater Temperature Failure

This error occurs if the detector heater temperature does not rise during warm-up, or if the temperature falls below 730°C or exceeds 780°C after warm-up is completed.

Causes considered for cases where Err-02 occurs independently are shown below.

- (1) Faulty heater in the detector (heater wire breakage).
- (2) Faulty thermocouple in the detector.
- (3) Failure in electrical circuits inside the converter.

<Locating cause of failure, and countermeasures>

- (1) Turn off the power to the analyzer.
- (2) Remove the probe from the analyzer. Also remove all the connectors between the converter and probe. Measure the resistance of the heater wire (yellow wire) from the probe as indicated in Figure 12.2. The heater assembly is normal if the resistance is lower than about 90 Ω. If the resistance is higher than that value, the heater assembly may be defective. In this case, replace the heater assembly (refer to Subsection 11.1.3, "Replacement of the Heater Assembly").

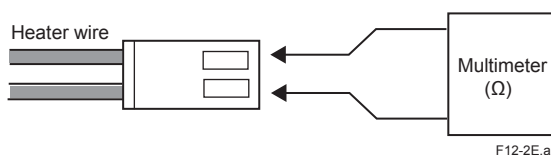

Figure 12.2

- (3) Next, check the resistance of the thermocouple from the probe. Use a multimeter to measure the thermocouple resistance between terminal 3 (red cable connected) and terminal 4 (white cable connected) as indicated in Figure 12.3.

The thermocouple is normal if the resistance is 5 Ω or less. If the value is higher than 5 Ω , the thermocouple wire may be broken or about to break. In this case, replace the heater assembly (refer to Subsection 11.1.3, "Replacement of the Heater Assembly").

NOTE

Measure the thermocouple resistance value after the difference between the probe tip temperature and the ambient temperature decreases to 50°C or less. If the thermocouple voltage is large, accurate measurement cannot be achieved.



Figure 12.3

- (4) If the inspection indicates that the thermocouple is normal, the electronics may be defective. Consult your local Yokogawa service or sales representative.

Err-03: A/D Converter Failure/Err-04: Writing-to-memory Failure

- **A/D Converter Failure**
It is suspected that a failure has occurred in the A/D converter mounted in the electrical circuits inside the converter.
- **Writing-to-memory Failure**
It is suspected that a failure has occurred in an operation writing to the memory (EEPROM) mounted in the electrical circuits inside the converter.

<Locating cause of failure, and countermeasures>

Turn off the power to the converter once and then restart the converter. If the converter operates normally after restarting, an error might have occurred due to a temporary drop in the voltage (falling below 85 V, the least amount of voltage required to operate the converter) or a malfunction of the electrical circuits affected by noise. Check whether or not there is a failure in the power supply system or whether the converter and detector are securely grounded.

If the error occurs again after restarting, a failure in the electrical circuits is suspected. Consult the service personnel at Yokogawa Electric Corporation.

12.2 Displays and Remedies When Alarms are Generated

12.2.1 Alarm types

When an alarm is generated, the alarm indication blinks in the display to notify of the alarm (Figure 12.4). Alarms include those shown in Table 12.2.



Figure 12.4

Table 12.2 Types of Alarms and Reasons for Occurrence

Alarm No.	Type of alarm	Reason for occurrence
AL-01	Oxygen concentration alarm	Occurs when a measured value exceed or falls below the set alarm value (refer to Section 8.3, "Alarm Setting").
AL-06	Zero calibration coefficient (correction ratio) alarm	Generated when the zero correction ratio is out of the range of $100\pm 30\%$ in automatic and semi-automatic calibration (refer to Subsection 9.1.3, "Compensation").
AL-07	Span calibration coefficient (correction ratio) alarm	Generated when the span correction ratio is out of the range of $0\pm 18\%$ in automatic and semi-automatic calibration (refer to Subsection 9.1.3, "Compensation").
AL-08	EMF stabilization time-up alarm	Generated when the cell (sensor) voltage is not stabilized even after the calibration time is up in automatic and semi-automatic calibration.
AL-10	Cold junction temperature alarm	Occurs when an equipment internal temperature exceeds 85°C .
AL-11	Thermocouple voltage alarm	Generated when thermocouple voltage exceeds 42.1 mV (about 1020°C) or falls below -5 mV (about -170°C).
AL-13	Battery low alarm	Internal battery needs replacement.

If an alarm is generated, actions such as turning off the heater power are not carried out. The alarm is released when the cause for the alarm is eliminated.

However, AL-10 and/or AL-11 may be generated at the same time as Err-02 (heater temperature failure).

In such a case, the measure taken for this error has priority.

If the converter power is turned off after an alarm is generated and restarted before the cause of the alarm has been eliminated, the alarm will be generated again.

However, AL- 6, 7, and 8 (alarms related to calibration) are not generated unless calibration is executed.

12.2.2 Remedies When Alarms are Generated

AL-01: Oxygen Concentration Alarm

This alarm is generated when a measured value exceeds an alarm set point or falls below it. For details on the oxygen concentration alarm, see Section 8.4, "Oxygen Concentration Alarms Setting," in the chapter on operation.

AL-06: Zero Calibration Coefficient (Correction Ratio) Alarm

In calibration, this alarm is generated when the zero correction ratio is out of the range of $100 \pm 30\%$ (refer to Subsection 9.1.3, "Compensation"). The following can be considered the causes for this:

- (1) The zero gas oxygen concentration does not agree with the value of the zero gas concentration set (refer to Subsection 9.2.1, "Calibration Setting.") Otherwise, the span gas is used as the zero gas.
- (2) The zero gas flow is out of the specified flow (600 ± 60 ml/min).
- (3) The sensor assembly is damaged and so cell voltage is not normal.

<Locating cause of alarm, and countermeasures>

- (1) Confirm the following and carry out calibration again: If the items are not within their proper states, correct them.
 - a. If the indication for "Zero gas conc." is selected in "Calibration setup," the set value should agree with the concentration of zero gas actually used.
 - b. The calibration gas tubing should be constructed so that the zero gas does not leak.
- (2) If no alarm is generated as a result of carrying out re-calibration, it is suspected that improper calibration conditions were the cause of the alarm in the preceding calibration. In this case, no specific restoration is necessary.
- (3) If an alarm is generated again as a result of carrying out re-calibration, deterioration of or damage to the cell (sensor) is suspected as the cause of the alarm. Replacement of the cell (sensor) with a new one is necessary. However, before replacement, carry out the following: Check the cell voltages when passing the zero gas and span gas.
 - a. Display the cell voltage with the parameter code A11.
 - b. Check whether or not the value of the displayed cell voltage is very different from the theoretical value at each oxygen concentration. Confirm the theoretical values of the cell voltage in Table 12.3. Although it cannot be generally specified as to what extent the difference from the theoretical value is allowed, consider it to be approximately ± 10 mV.

Table 12.3 Oxygen Concentration and Cell Voltage

Oxygen concentration (% O ₂)	Cell voltage (mV)
1%	67.1
21%	0

- (4) Confirm whether deterioration of or damage to the sensor assembly that caused the alarm has occurred abruptly during the current calibration in the following procedure: Check the history of the span gas correction ratio with the parameter codes A50 through A51, Check the history of the zero gas correction ratio with the parameter codes A60 through A69. The larger the parameter code number, the older the displayed data. Changes in deterioration of the sensor can be seen.
- (5) If deterioration of the cell assembly has occurred abruptly, it may show that the check valve, which prevents moisture in the furnace from getting into the calibration gas tubing, has failed. If the gas in the furnace gets into the calibration gas tubing, it condenses and remains in the gas

- tubing. The cell assembly is considered to be broken for the reason that the condensation is blown into the cell assembly by the calibration gas during calibration and so the cell cools quickly.
- (6) If the cell assembly has been gradually deteriorating, check the cell assembly status in the following procedure:
 - a. Display "Cell resistance" by specifying the parameter code A21. A new cell will show a cell resistance value of 200 Ω or less. On the other hand, a cell (sensor) that is approaching the end of its service life will show a resistance value of 3 to 10 k Ω .
 - b. Display "Cell robustness" by specifying the parameter code A22. A good cell (sensor) will show "5," "life > 1 year" (refer to Subsection 9.1.10).

AL-07: Span Calibration Coefficient (Correction Ratio) Alarm

In calibration, this alarm is generated when the span gas correction ratio is out of the range of $0 \pm 18\%$ (refer to Subsection 9.1.3, "Compensation").

The following are suspected as the cause:

- (1) The oxygen concentration of the span gas does not agree with the value of the span gas set "Calibration setup."
- (2) The flow of the span gas is out of the specified flow value (600 ± 60 ml/min).
- (3) The cell assembly is damaged and the cell voltage is abnormal.

<Locating cause of alarm, and countermeasures>

- (1) Confirm the following and carry out calibration again:
If the items are not within their proper states, correct them.
 - a. If the display "Span gas conc." is selected in "Calibration setup," the set value should agree with the concentration of span gas actually used.
 - b. The calibration gas tubing should be constructed so that the span gas does not leak.
- (2) If no alarm is generated as a result of carrying out re-calibration, it is suspected that improper calibration conditions were the cause of the alarm in the preceding calibration. In this case, no specific restoration is necessary.
- (3) If an alarm is generated again as a result of carrying out re-calibration, deterioration of or damage to the cell (sensor) is suspected as the cause of the alarm. Replacement of the cell with a new one is necessary. However, before replacement, carry out the procedure described in step (3) and later of <Locating cause of failure, and countermeasure> in Subsection 12.2.2, "AL-06: Zero Calibration Coefficient Alarm."

AL-08: EMF Stabilization Time Over

This alarm is generated if the sensor (cell) voltage has not stabilized even after the calibration time is up for the reason that the calibration gas (zero gas or span gas) has not filled the sensor assembly of the detector.

<Cause of alarm>

- (1) The flow of the calibration gas is less than normal (a specified flow of 600 ± 60 ml/min).
- (2) The length or thickness of the calibration gas tubing has been changed (lengthened or thickened).
- (3) The measuring gas flows toward the tip of the probe.
- (4) The sensor (cell) response has deteriorated.

<Locating cause of alarm, and countermeasures>

- (1) Carry out calibration by passing the calibration gas at the specified flow (600 ± 60 ml/min) after checking that there is no leakage in the tubing.
- (2) If calibration is carried out normally, perform a steady operation without changing the conditions. If the error occurs again, check whether or not the reason is applicable to the following and then replace the sensor assembly.
 - A lot of dust and the like may be sticking to the tip of the sensor. If dust is found, clean and remove the dust (see Subsection 11.1.1).

In addition, if an error occurs in calibration even after the cell assembly is replaced, the influence of sample gas flow may be suspected. Do not let the sample gas flow toward the tip of the detector probe, for example, by changing the mounting position of the detector.

AL-10: Cold Junction Temperature Alarm

The equipment incorporates a temperature sensor. An alarm is issued when the sensor temperature exceeds 85°C . If internal temperature of this equipment exceeds 85°C , the electronics may fail.

<Locating cause of alarm, and countermeasures>

This equipment can be used at ambient temperatures up to 55°C . If the ambient temperatures may exceed the limits, take appropriate measures — such as applying heat insulating material to the furnace walls, and adding a sun shield to keep out direct sunlight.

If this alarm occurs even when the ambient temperature is under 55°C , the electronics may be defective. Contact your local Yokogawa service or sales representative.

AL-11: Thermocouple Voltage Alarm

This alarm is generated when the e.m.f. (voltage) of thermocouple falls below -5 mV (about -170°C) or exceeds 42.1 mV (about 1020°C). Whenever AL-11 is generated, Err-02 (heater temperature failure) occurs.

- (1) Breakage of the heater thermocouple signal wire between the converter and the detector occurred, or the cable is not securely connected to the connecting terminals.
- (2) The positive and negative poles of the heater thermocouple signal wiring are shorted out in the wiring extension or at the connection terminals.
- (3) A failure of the thermocouple at the detector occurred.
- (4) A failure of the electrical circuits occurred.

<Locating cause of alarm, and countermeasures>

- (1) Stop the power to the converter.
- (2) Remove the wiring from terminals 3 and 4 of the detector and measure the resistance between these terminals. If the resistance value is 5Ω or less, the thermocouple seems to be normal. If it is higher than 5Ω , it may indicate the possibility that the thermocouple has broken or is about to break. In this case, replace the heater unit (refer to Subsection 11.1.3, "Replacement of the Heater Unit").

 **CAUTION**

Measure the thermocouple resistance value after the difference between the probe tip temperature and the ambient temperature decreases to 50°C or less. If the thermocouple voltage is large, accurate measurement cannot be achieved.

- (3) If the thermocouple is normal, check whether or not the wiring cable is broken or shorted out, and also whether the wiring cable is securely connected to the terminals. Also check that the wiring resistance between the converter and the detector is 10 Ω or less.
- (4) If there is no failure in the wiring, the electrical circuits inside the converter may possibly fail. Contact the service personnel at Yokogawa Electric Corporation.

AL-13: Battery Low Alarm

An internal battery is used as backup for the clock. After this alarm occurs, removing power from the instrument may cause the clock to stop but should not affect stored parameters. The internal clock is used for calibration and purge scheduling; if you use this then after a battery alarm occurs (until the battery is replaced) be sure to check / correct the date and time every time you turn on the power.

<Corrective action>

When the battery low alarm occurs, remember that the battery cannot be replaced by the user. Contact your Yokogawa service representative.

NOTE

Battery life varies with environmental conditions.

- If power is applied to the instrument continuously, then the battery should not run down, and life is typically about ten years. However the battery will be used during the time interval between shipment from the factory and installation.
 - If power is not applied to the instrument, at normal room temperatures of 20 to 25°C then battery life is typically 5 years, and outside this range but within the range -30 to +70°C then battery life is typically 1 year.
-

12.3 Measures When Measured Value Shows an Error

The causes that the measured value shows an abnormal value is not always due to instrument failures. There are rather many cases where the causes are those that measuring gas itself is in abnormal state or external causes exist, which disturb the instrument operation. In this section, causes of and measures against the cases where measured values show the following phenomena will be described.

- (1) The measured value is higher than the true value.
- (2) The measured value is lower than the true value.
- (3) The measured value sometimes shows abnormal values.

12.3.1 Measured Value Higher Than True Value

<Causes and Measures>

- (1) The measuring gas pressure becomes higher.
The measured oxygen concentration value X (vol%O₂) is expressed as shown below, when the measuring gas pressure is higher than that in calibration by Δp (kPa).

$$X=Y [1+ (\Delta p/101.30)]$$

where Y: Measured oxygen concentration value at the same pressure as in calibration (vol%O₂).
Where an increment of the measured value by pressure change cannot be neglected, measures must be taken.

Investigate the following points to perform improvement available in each process.

- Is improvement in facility's aspect available so that pressure change does not occur?
 - Is performing calibration available under the average measuring gas pressure (internal pressure of a furnace)?
- (2) Moisture content in a reference gas changes (increases) greatly.
If air at the detector installation site is used for the reference gas, large change of moisture in the air may cause an error in measured oxygen concentration value (vol%O₂).
When this error is not ignored, use a gas in which moisture content is constant such as instrument air in almost dry condition as a reference gas.
In addition, change of moisture content in exhaust gas after combustion is also considered as a cause of error. However, normally this error is negligible.
 - (3) Calibration gas (span gas) is mixing into the sensor due to leakage.
If the span gas is mixing into the sensor due to leakage as a result of failure of the valve provided in the calibration gas tubing system, the measured value shows a value a little higher than normal.
Check valves (needle valves, check valves, solenoid valves for automatic calibration, etc.) in the calibration gas tubing system for leakage. For manual valves, check them after confirming that they are in fully closed states. In addition, check the tubing joints for leakage.
 - (4) The reference gas is mixing into the measuring gas and vice versa.
Since the difference between oxygen partial pressures on the sensor anode and cathode sides becomes smaller, the measured value shows a higher value.
An error which does not appear as the Err-01 may occur in the sensor. Sample gas and/or the reference gas may be leaking. Visually inspect the sensor. If any crack is found, replace the sensor assembly with a new one.

(Note) : Data such as cell robustness displayed in the detailed data display should also be used for deciding sensor quality as references.

12.3.2 Measured Value Lower Than True Value

<Causes and Measures>

- (1) The measuring gas pressure becomes lower.
Where an increment of the measured value due to pressure change cannot be neglected, take measures referring to Subsection 12.3.1 (1).
- (2) Moisture content in a reference gas changes (decreases) greatly.
If air at the analyzer installation site is used for the reference gas, large change of moisture content in the air may cause an error in measured oxygen concentration value (vol%O₂).
When this error is not ignored, use a gas in which moisture content is constant such as instrument air in almost dry condition as a reference gas.
In addition, change of moisture content in exhaust gas after combustion is also considered as a cause of error. However, normally this error is negligible.
- (3) Calibration gas (zero gas) is mixed into the sensor due to leakage.
If the zero gas is mixed into the detector due to leakage as a result of failure of the valve provided in the calibration gas tubing system, the measured value shows a value a little lower than normal.
Check valves (needle valves, check valves, solenoid valves for automatic calibration, etc.) in the calibration gas tubing system for leakage. For manual valves, check them after confirming that they are in fully closed states.
- (4) Combustible components exist in the sample gas. If combustible components exist in the sample gas, they burn in the sensor and thus oxygen concentration decreases. Check that there are no combustible components.
- (5) Temperature of the sensor cell reaches 750°C or more.
If the sensor temperature is 750°C or higher, this may indicate that sample gas has leaks into the reference gas side, corrosion. Also check that the thermocouple resistance is no greater than 15Ω.

12.3.3 Measurements Sometimes Show Abnormal Values

<Cause and Measure>

- (1) Noise may be mixing in with the converter from the detector output wiring.
Check whether the equipment is securely grounded.
Check whether or not the signal wiring is laid along other power cords.
- (2) The converter may be affected by noise from the power supply.
Check whether or not the converter power is supplied from the same outlet, switch, or breaker as other power machines and equipment.
- (3) There may be a crack in the sensor or leakage at the sensor-mounting portion.
If the indication of concentration varies in synchronization with the pressure change in the furnace, check whether or not there is a crack in the sensor or whether the sensor flange is sticking tightly to the probe-attaching face with the metal O-ring squeezed.
- (4) There may be leakage in the calibration gas tubing
In the case of a negative furnace inner pressure, if the indication of concentration varies with the pressure change in the furnace, check whether or not there is leakage in the calibration gas tubing.

Customer Maintenance Parts List

Model ZR202S
Zirconia Oxygen Analyzer
(Integrated type Explosion-proof)

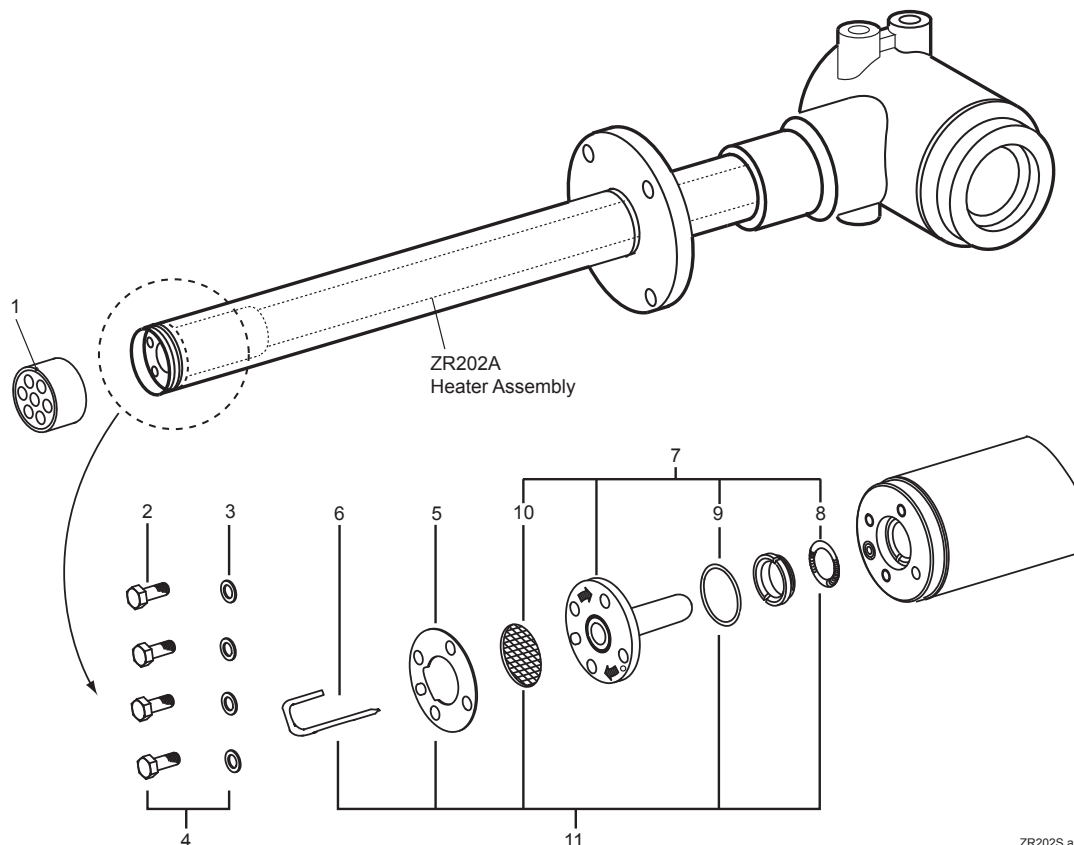

Item	Part No.	Qty	Description
1	K9477EA	1	Flame Arrestor
2	---	4	Bolt
	G7109YC		(M5x12, SUS316 stainless steel)
	K9470BK		(M5x12, inconel) for Option code "/C"
3	E7042DW	4	Washer (SUS316 stainless steel)
4	---	1	Bolts and Washers
	K9470ZF		G7109YC x 4 + E7042DW x 4
	K9470ZG		K9470BK x 4 + E7042DW x 4 for Option code "/C"
5	E7042BR	1	Plate
6	K9470BM	1	Pipe
7	K9473AN	1	Pipe for Option code "/C"
	---	1	Cell Assembly
	E7042UD		only for Japan
	ZR01A01		for other than Japan
8	E7042BS	1	Contact
9	K9470BJ	1	Metal O-ring
10	E7042AY	1	Filter
11	---		Calibration Tube Assembly
	K9470ZK		Cal. Gas Tube Assembly
	K9470ZL		Cal. Gas Tube Assembly for Option code "/C"

Hood for ZR202S

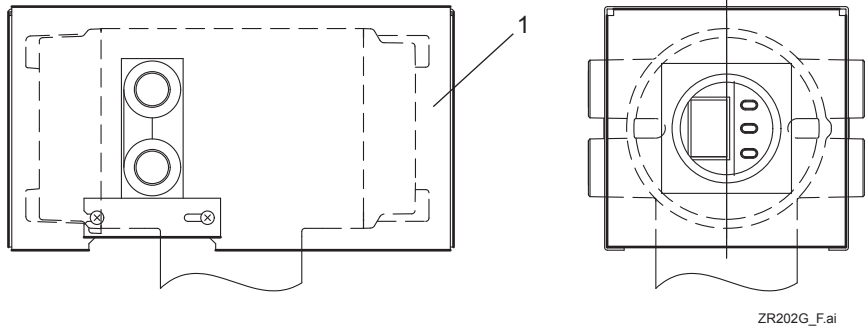

Item	Part No.	Qty	Description
1	K9472UF	1	Hood

Automatic Calibration Unit

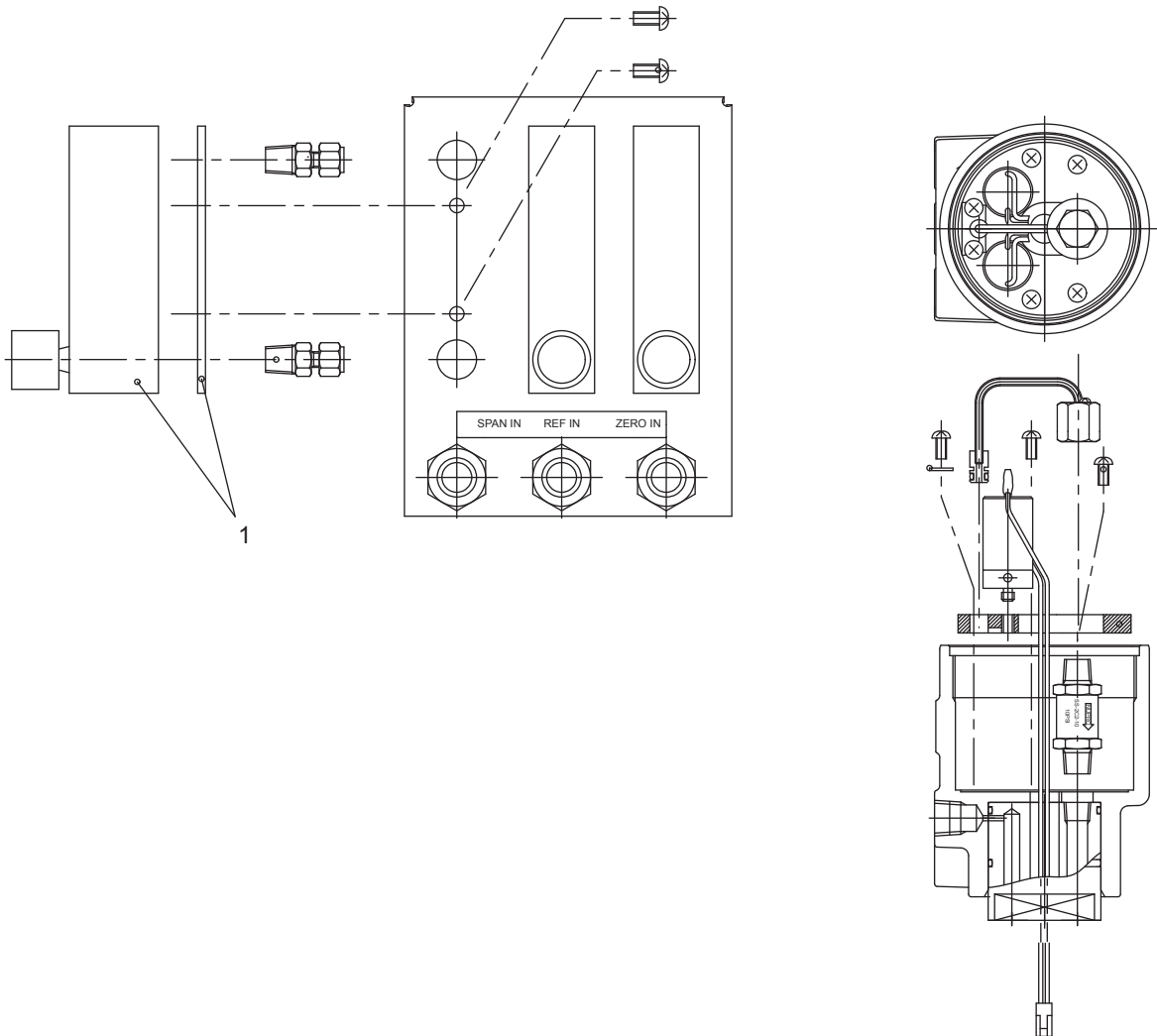

Item	Part No.	Qty	Description
1	K9473XC	1	Flowmeter

Customer Maintenance Parts List

Model ZO21S
Zirconia Oxygen Analyzer/ High Temperature
Humidity Analyzer, Standard Gas Unit

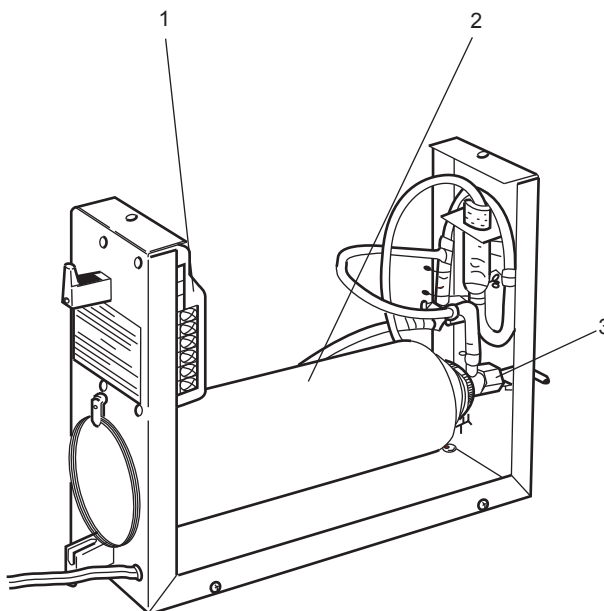

Item	Part No.	Qty	Description
1	—	1	Pump (see Table 1)
2	E7050BA	1	Zero Gas Cylinder (x6 pcs)
3	E7050BJ	1	Needle Valve

Table 1

Power	Pump
AC 100 V 110 115	E7050AU
AC 200 V 220 240	E7050AV

Revision Information

- Title: Model ZR202S Integrated type Explosion-proof Zirconia Oxygen Analyzer
- Manual No.: IM 11M13A01-04E

Edition	Date	Remark (s)
13th	Nov. 2021	Updated the NAME PLATE. (page 2-2, 2-3) Added the operation procedure. (page 3-1)
12th	Jul. 2021	Corrected (page 2-4)
11th	June 2021	Revised RoHS conformity standards. (page 2-4), Corrected (pages viii, 2-1, 2-2, 2-3, 3-2, 3-3), Changed EU Declaration of Conformity
10th	Oct. 2019	Added a figure of dimension. (page 2-11) CMPL 11M13A01-04E revised to 5th edition.
9th	Feb. 2019	Added EAC Flameproof certificate description. (page 2-3)
8th	May 2018	Added WEEE directive information. (page 2-3)
7th	Jul. 2017	Changed flange materials of ZR202S and ZO21R. (pages 2-5, 2-8, 2-9, 2-11)
6th	June 2017	Add RoHS compliance statement with some revision on pages i, iv, viii, ix, 2-1, 2-2, 2-3, 2-4, 2-5, 2-8, 3-2, 3-5, 3-6.
5th	Apr. 2016	Addition the related documents, etc. CMPL 11M13A01-04E revised to 4th edition.
4th	Aug. 2015	Revised section 2.1.1 "Standard Specifications" NAME PLATE: Addition of the certificate number and maximum surface temperature for dust-proof. "Standard Specifications" NAME PLATE: The correction of the type of protection and marking code. "General Specifications": Added to "Standard Specifications" 2.4.1 "Stop Valve": Changed of the weight and dimensions. 2.4.2 "Check Valve": Changed of the weight.
3rd	Dec. 2014	Revised and Corrected over all
2nd	Aug. 2006	Revised Section Introduction "WARNING": Deleted description. Explosion-proof Approval: Added description. 2. "WARNING": Deleted description. 2.1.2 "ZR202S Integrated-type Explosion-proof Oxygen Analyzer": Added Applicable Standard and Certificate. "ZR202S Integrated-type Explosion-proof Oxygen Analyzer" Safety and EMC conforming standards: Added Caution. "ZR202S Integrated-type Explosion-proof Oxygen Analyzer" Model and Suffix Codes: Added one suffix code, Added Note. 2.4.4 "Pressure Regulator for Gas Cylinder (Part No. G7013XF or G7014XF)": Change drawing.

-
- 3.1.5 “IECEX Flameproof Type” Note1: Added Applicable Standard and Certificate.
 - 5.3 “Wiring Power and Ground Terminals”: Added description in Figure 5.5.
 - 5.3.2 “Wiring for Ground Terminals”: Added item (4).
 - 7.4.5 “Changing Set Values”: Made corrections in table (1).
 - 7.9.2 “Checking Calibration Contact Output”: Made corrections in Table 7.11.
 - 8.3 “Output Hold Setting,” “Table 8.4 Analog Output Hold Setting”: Added Note.
 - 8.3.2 “Preference Order of Output Hold Value”: Deleted “or blow-back”.
 - 8.3.3 “Output Hold Setting”: Made corrections and changed descriptions in Table 8.5, added note
 - 8.3.4 “Default Values”: Changed descriptions in Table 8.6.
 - 8.5.1 “Output Contact”: Made corrections.
 - 8.5.2 “Setting Output Contact”: Table 8.10, Changed descriptions,
WARNING: Deleted second warning.
 - 8.5.3 Changed layout.
 - 8.7.4 “Setting Purging”: Added item.
 - 10.4 “Reset,” “Table Output-related Items in Group C”: Added Note.
 - 10.6 Output-related Items in Group C. Deleted some codes.
Contact-related Items in Group E. Deleted some codes.
 - 12.2.1 “What is an Alarm?”: Table 12.2, Added Alarms 11 and 13.
 - 12.2.2 Alarm 6: Changed descriptions, Alarm 7: Changed descriptions
Added Alarm11, Alarm 13
 - CMPL 11M13A01-04E Changed part numbers

1st Apr. 2005
Newly published

YOKOGAWA ◆

Doc No: AEN367-C04

EU DECLARATION OF CONFORMITY

We **Yokogawa Electric Corporation**
2-9-32 Nakacho, Musashino-shi, Tokyo, 180-8750 Japan

declare under our sole responsibility that the Products identified as:

Model code Model name
ZR202S Integrated type Explosion-proof Zirconia Oxygen Analyzer
specified with the first suffix code: **-A**

As part of Product Family: **EXAxt**
further specified with model suffix and option codes:

As listed in General Specification: GS 11M13A01-01E (Ed.12)
See Appendix 2 for additional information.

are in compliance with the EU law and legislation providing for the CE-marking, as listed in Appendix 1.

Information relevant to the conformity and identification of these Products is provided in Appendix 2, Appendix 3 and Appendix 4.

Subject products are:

- Produced according to appropriate quality control procedure.
- Provided with the CE-marking as from **2005**.

Signature:

(Manufacturer)

Tokyo, 3 June 2021

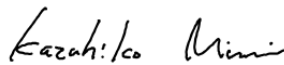

Kazuhiko Mimori
General Manager
Analyzer Development Dept.
Development Div. Sensing Center
Yokogawa Products HQ
Yokogawa Electric Corporation

(Authorized Representative in the EEA)

Amersfoort, 6/17/2021

DocuSigned by:



CF100A7E1BA3469

Andreas Helget
President
Yokogawa Europe B.V.
Euroweg 2, 3825 HD Amersfoort,
P.O.Box 163, 3800 AD Amersfoort,
The Netherlands

Appendix 1

The products are built in compliance with requirements of the following EU Directives and Standards;

Model – Suffix / Option code structure: **ZR202S – A – ccc – d – e – f – g – h – i – j – k / x**
(Distinctive combinations of suffix and option codes as indicated per table. Unless otherwise stated, it means that all defined code is relevant.)

EU Directive	Standards
2014/30/EU (EMC)	<p>EN 61326-1:2013 Class A Table 2 Electrical equipment for measurement, control and laboratory use – EMC requirements- Part 1: General requirements</p> <p>EN 61326-2-3:2013 Electrical equipment for measurement, control and laboratory use – EMC requirements – Part 2-3: Particular requirements - Test configuration, operational conditions and performance criteria for transducers with integrated or remote signal conditioning</p> <p>EN 61000-3-2:2014 Electromagnetic compatibility (EMC) -- Part 3-2: Limits - Limits for harmonic current emissions (equipment input current <= 16 A per phase)</p>
2014/35/EU (LVD)	<p>EN 61010-1:2010 Safety requirements for electrical equipment for measurement, control, and laboratory use – Part 1: General requirements</p> <p>EN 61010-2-030:2010 Safety Requirements for Electrical Equipment for Measurement, Control and Laboratory Use, Part 2-030: Particular requirements for testing and measuring circuits</p>
2011/65/EU *1,2 (RoHS)	<p>EN IEC 63000:2018 Technical documentation for the assessment of electrical and electronic products with respect to the restriction of hazardous substances.</p>
2014/34/EU *3 (ATEX)	<p>EN IEC 60079-0:2018 Explosive atmospheres - Part 0: Equipment-General requirements</p> <p>EN 60079-1:2014 Explosive atmospheres - Part 1: Equipment protection by flameproof enclosures "d"</p> <p>EN 60079-31:2014 Explosive atmospheres - Part 31: Equipment dust ignition protection by enclosure "t"</p> <p> II 2 G Ex db IIB+H₂ T2 Gb II 2 D Ex tb IIIC T300°C Db</p> <p>The Number of the EU Type-Examination Certificate: KEMA 04ATEX2156 X</p> <p>EU Type Examination Certificate listed above and Quality Assurance Notification are issued by: The Name of the Notified Body: DEKRA Certification B.V. The Identification Number of the Notified Body: 0344 The Address of the Notified Body: Meander 1051 6825 MJ Arnhem, The Netherlands The Number of Quality Assurance Notification: DEKRA 11ATEXQ0127</p>

*1: Including the Commission Delegated Directive (EU) 2015/863 that defines the ten (10) restricted substances and amends Annex II to Directive 2011/65/EU.

*2: Products on and after the production date of June 1st 2021 are the RoHS compliant products.
Production date is indicated following the serial number and is located on the right side of the frame of "NO." in the name plate.
Year and Month of the production are indicated such as '2021.06'.

*3: The listed standards have been compared to the standards EN 60079-0:2012+A11:2013, EN 60079-1:2014 and EN 60079-31:2014 used for certification purposes, but no clauses containing changes in state-of-art apply to this product.

Appendix 2

In case the Product model code contains the code "Z", it means that the Product is produced with a customer specific modification. Any such Product - in case produced after the date of signing this document by the Manufacturer - is also in scope of this EU-Declaration of Conformity. The code "Z"- specific application notes and Serial Numbers of Products subject to this modification are listed in a dedicated document, of which original is a part of the Technical Documentation. A copy of that document is accompanying each product at delivery.

Appendix 3

The accessories in the list below have CE-marking significant compliance relevance, as indicated per EU-Directive; their application and use – as described in **IM 11M13A01-04E** – is supported by this EU Declaration of Conformity. The full list of accessories for this product can be found in **IM 11M13A01-04E**.

Indications: 'C' = *The accessory conforms to the Directive as a part of the product.*

'R' = *The accessory is relevant to the conformity of the product as a part of the product.*

'NS' = *The accessory does not support the Directive.*

'NR' = *The accessory is not relevant to the conformity of the product.*

Model No.	Model Name	Relevant EU Directives			
		EMC	LVD	RoHS	ATEX
ZO21R	Probe Protector	NR	NR	C	NR
ZR202A	Heater Assembly	C	C	C	NR
IM 11M13A01-04E	User's Manual	R	R	R	R

Appendix 4

External View of ZR202S



Image of Nameplate
(Typical example; details may differ)

INTEGRAL TYPE ZIRCONIA ANALYZER		<p style="text-align: center;">⚠ WARNING</p> <ul style="list-style-type: none"> · DO NOT OPEN WHEN AN EXPLOSIVE GAS ATMOSPHERE IS PRESENT · POTENTIAL ELECTROSTATIC CHARGING HAZARD - READ USER'S MANUAL (IM 11M13A01-04) · FOR INSTALLATION AND SAFE USE, READ IM 11M13A01-04 <p style="text-align: center;">⚠ HIGH TEMPERATURE</p> <ul style="list-style-type: none"> · USE AT LEAST 80°C HEAT RESISTANT CABLES & CABLE GLANDS <p style="text-align: right;">   <small>KCC-REM-YHQ- EEN103-2-R1</small> </p>
MODEL	ZR202S	
SUFFIX	-A-040-S-E-N -E-T-T-E-A/SV	
STYLE	S1	
SUPPLY	100-240V AC~ 50/60Hz MAX.300W	
AMB. TEMP	-20 TO 55°C	
NO.	91XX12345 2017.06	
CE0344 Ex II2GD		
No. KEMA 04ATEX2156 X		
Ex db IIB+H₂ T2 Gb		
Ex tb IIIC T300°C Db		
ENCLOSURE : IP66		
YOKOGAWA ◆ Made in Japan		Yokogawa Electric Corporation Tokyo 180-8750 JAPAN

-/-