

General Specifications

FN510 Field Wireless Multi-Function Module



GS 01W03E01-01EN

■ GENERAL

This General Specification (GS) describes the specifications for Field Wireless Multi-Function Module.

Combined with "Field Wireless Communication Module FN110", this product is connectable with a field wireless network as a field wireless device. This product acquires sensor data from a connected sensor and transmits it to a field wireless network through FN110.

Refer to General Specifications of "Field Wireless Communication Module FN110" for an overview and detailed information.



■ FEATURES

● Various Input / Output functions

Analog input, digital input/output or pulse input are selectable (Measurement code: A).

ACAI function; from the AC voltage to dedicated accelerometer input, acceleration or velocity can be measured (Measurement code: C).

● Connect various sensor to the field wireless network

This product transmits sensor value acquired from a 4-20 mA analog device (Measurement code: A) or a dedicated accelerometer (Measurement code: C) to the host system via field wireless network.

● Installation flexibility

Cable elimination allows installing a device at locations where it was previously either inaccessible or cost-prohibitive because of cable management and cost.

● Small and lightweight housing with LCD

This product has a small and lightweight housing with a built-in LCD that displays the process data and communication status.

■ STANDARD SPECIFICATIONS

□ POWER SUPPLY SPECIFICATIONS

Battery:

Dedicated battery pack.

Rated voltage: 7.2 V

Rated capacity: 19 Ah

Battery Pack:

2x primary lithium-thionyl chloride batteries

With battery case (batteries sold separately)

□ PERFORMANCE SPECIFICATIONS

Update Period:

[Measurement code: A]
1 to 3600 s selectable*

*: When using the digital output, more than 2 s is accepted.

[Measurement code: C]
10 to 3600 s selectable

Battery Characteristics:

[Measurement code: A]

Typical battery life when using analog input or digital input is 10 years*¹ or 7 years*² and when using digital output with always on is 3 years*³ or 2 years*¹ in the following conditions.*⁴

- Ambient temperature: 23 ±2°C
- Device role: IO mode
- LCD display: off

*¹: Update period: 10 s

*²: Update period: 5 s

*³: Update period: 30 s

*⁴: Environmental condition such as vibration and the type of connected device may affect the battery life.

[Measurement code: C]

Typical battery life when using piezoelectric accelerometer is 10 years*¹ or 2 years*² in the following conditions.*³

- Ambient temperature: 23 ±2°C
- Device role: IO mode
- LCD display: off
- Sampling frequency: 20 kHz
- Sampling points: 1024 points

*¹: Update period: 60 s

*²: Update period: 10 s

*³: Environmental condition such as vibration and the type of connected device may affect the battery life.

Accuracy:

- [Measurement code: A]
See Table 1.
- [Measurement code: C]
See Table 2.

□ **FUNCTIONAL SPECIFICATIONS**

Input:

- [Measurement code: A]
See Table 1.
- [Measurement code: C]
See Table 2.

Output:

- Communication specifications between this product and FN110 are below.
- Communication Mode: Half-duplex communication (RS485 compliant)
- Communication Speed: 9600 bps
- Connector: 5-pin round connector dedicated
- Cable: Max 20 m (dedicated cable)

Power Supply:

- Power supply to the FN110
 - Supply voltage: 3.5 V
 - Supply current: 50 mA
- Power supply to sensors
 - [Measurement code: A]
None
 - [Measurement code: C]
See Table 2

Integral Indicator (LCD display):

- 5-digit numerical and status display. Display contents and display on/off can be controlled with a magnet (not included).
- The indicator displays the following information:
 - Wireless communication status, device status, write protection status, sensor data and alarm message

Diagnosis Functions:

- Power failures, wired communication failures, firmware internal errors, memory errors, battery alarm, abnormal temperature

Software Download Function:

- Software download function permits to update wireless field device software via ISA100 Wireless communication.

□ **INSTALLATION ENVIRONMENT**

Ambient Temperature Limits:

- Operating: -40 to 85°C (altitude up to 3000 m)
-30 to 80°C (LCD visible range)
- Storage: -40 to 85°C

Ambient Humidity Limits:

- Operating: 0 to 100%RH (non-condensation)
- Storage: 0 to 100%RH (non-condensation)

Ambient Temperature Gradient:

- Operating: ±10°C/h or less
- Storage: ±20°C/h or less

Vibration Resistance:

- 0.21 mm P-P (10 - 60 Hz), 3G (60 - 2 kHz)

Shock Resistance:

- 50 G 11 ms

□ **REGULATORY COMPLIANCE STATEMENTS**

This product satisfies the following standards.

- * Please confirm that an installation region fulfills an applicable standard. If additional regulatory information and approvals are required, contact a Yokogawa representative.

CE Conformity:

- EMC Directive:
EN61326-1 Class A Table 2, EN55011 Class A
- RoHS Directive:
EN IEC 63000
- ATEX Directive:
See "OPTIONAL SPECIFICATIONS (For Explosion Protected Types)"
- Other Normative Standards:
Safety: EN61010-1 (Indoor/Outdoor use)

Canadian Safety Standards:

- CAN/CSA-C22.2 No.61010-1
- CAN/CSA-C22.2 No.94.1, CAN/CSA-C22.2 No.94.2
- IEC 60529

Degrees of Protection:

- IP66, IP67 and Type 4X apply when the connector is properly tightened.

□ **PHYSICAL SPECIFICATIONS**

Connections:

- Refer to "MODEL AND SUFFIX CODES"

Housing Material:

- Plastic (Polycarbonate)

Weight:

- 500 g (without mounting bracket and battery)

Mounting:

- 2-inch pipe mounting

[Measurement code: A]

Table 1 Input / Output Specifications for Measurement code A

Function	Item	Specification
4-20 mA Analog Input (AI) *1	Number of input channels	1
	Input signal	4 to 20 mA DC
	Range	0 to 25 mA
	Internal shunt resistor	10 ohm
	Accuracy	±16 uA
	Temperature coefficient	±3.2 uA/10°C
Digital Input (DI) *1 *2	Number of input channels	2
	Input signal	Dry contact input
	Maximum on resistance	200 Ω
	Minimum off resistance	50 kΩ
	Current value when contact is on	IN1 IN2
Digital Output(DO) *1 *3	Number of output channels	1
	Output signal	Dry contact output
	Maximum load current	125 mA DC
	Maximum load voltage	30 V DC
Pulse Input (PULSE) *1 *2	Number of input channels	1
	Input signal	Dry contact input *2
	Maximum on resistance	200 Ω
	Minimum off resistance	50 kΩ
	Minimum detection time *4	5 ms
	Maximum input frequency	100 Hz
	Counter range	0 to 999999

*1: The input channels are non-isolated and share one common ground.

*2: Do not apply a voltage to a DI or PULSE from the outside.

*3: The digital output terminal is configured as open-drain. The voltage and current applied to a digital output terminal should be within the specified range.

*4: Minimum time required to detect an external contact becomes off.

[Measurement Code: C]

Table 2 Input Specifications for Measurement code C

Function	Item	Specification
AC Analog Input (AI)	Number of input channels	1
	Input signal	0.1 to 3.2 V AC
	Sensing mode *1	Acceleration, Velocity, Velocity LPF 160 Hz (Gain High, Gain Low)
	Measurement data	Peak, RMS, Peak/RMS
	Sampling frequency	1, 2, 5, 10, 20 kHz
	Sampling points	1024, 2048, 4096 points
	Frequency range *2*3	10 Hz to 10000 Hz
	Range *3	Acceleration: 0 to 300 m/s ² Velocity: 0 to 160 mm/s
	Accuracy (100 Hz) *4*5	Acceleration: ±(2% of reading + 2 m/s ² rms) Velocity: ± (10% of reading + 1 mm/s rms)
	Sensor power supply voltage	3.4 V typ.
	Sensor power supply current	10 mA max.

*1: Acceleration mode is used to measure the relatively high frequency vibration. Velocity mode is used to measure the relatively low frequency vibration. Velocity LPF 160 Hz mode is used to measure the near 160 Hz.

*2: Range is due to combination of LN01 Piezoelectric Accelerometer.

*3: The relationship of the measurement frequency and the measurement range due to combination of LN01 Piezoelectric Accelerometer, see Figure 1 and 2.

*4: This is an accuracy of only FN510. (Ambient temperature -40 to 85°C, the entire measurement range).

*5: Measurement accuracy due to combination of LN01 Piezoelectric Accelerometer, see Table 3.

Table 3: Measurement accuracy with combination of LN01 Piezoelectric Accelerometer (reference value)

Conditions	Accuracy (100 Hz)
Ambient temperature -40 to 85°C, the entire measurement range	Acceleration: -27 to +17% of reading $\pm 2 \text{ m/s}^2 \text{ rms}$ Velocity: -35 to +25% of reading $\pm 1 \text{ mm/s rms}$
Ambient temperature $25 \pm 10^\circ\text{C}$, the entire measurement range	Acceleration: $\pm (15\% \text{ of reading} + 0.8 \text{ m/s}^2 \text{ rms})$ Velocity: $\pm (23\% \text{ of reading} + 0.2 \text{ mm/s rms})$

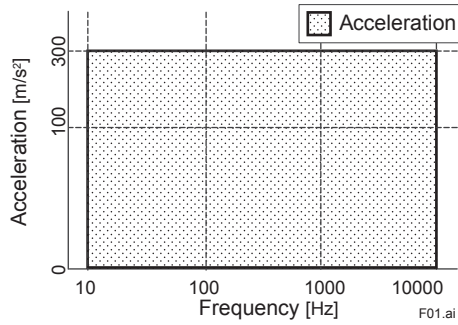

Figure 1 Measurement Range (Acceleration)

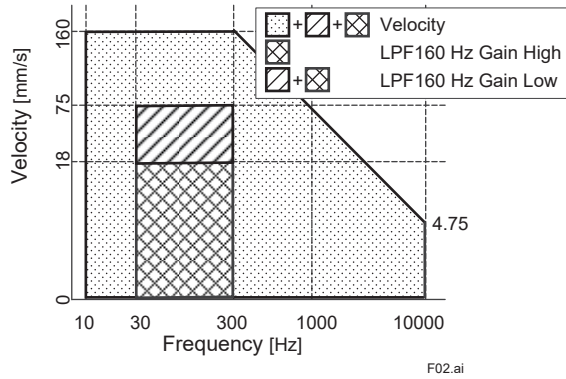

Figure 2 Measurement Range (Velocity)

MODEL AND SUFFIX CODES

Model	Suffix Code	Descriptions
FN510	Field Wireless Multi-Function Module
General Specification	Inter module communication	-A1 Digital communication for FN series
	---	-A Always A
	Housing material	0 Plastic (Polycarbonate)
	Electrical connection	0 Horizontal connection: blind plug, Vertical connection: G 1/2 female *1
		1 Horizontal connection: blind plug, Vertical connection: 1/2 NPT female *1
		2 Horizontal connection: blind plug, Vertical connection: M20 female *1
		6 Horizontal connection: blind plug, Vertical connection: blind plug *2
	Measurement	A One analog input *3, two digital input, one digital output, one pulse input *3
		C Single analog input by AC voltage with power supply*4
	Integral indicator	-D Digital indicator
	Mounting bracket	J 316 SST 2-inch pipe mounting (for horizontal piping)
		K 316 SST 2-inch pipe mounting (for vertical piping)
		N None
	---	A Always A
---	A Always A	
---	-A Always A	
---	A Always A	
Option codes		/□ Optional specifications

- *1: Cable gland is not included. Prepare the cable gland with a flat gasket.
- *2: Select when use as a routing device.
- *3: Analog input and pulse input are able to use exclusively with other functions.
- *4: LN01 Piezoelectric Accelerometer (for FN series) is required.

■ OPTIONAL SPECIFICATIONS (For Explosion Protected Types)

Please select appropriate equipment in accordance with the laws and regulations of the relevant country/region, when it is used in a location where explosive atmospheres may be present.

Item		Description	Code
Factory Mutual (FM)	United States	FM Intrinsically safe Approval (United States) Applicable Standards: FM 3600, FM 3610, FM 3810, ANSI/UL 60079-0, ANSI/UL 60079-11, NEMA 250, ANSI/IEC 60529 Specific Ex marking: IS CL I/II/III DIV1 GP CDEFG T4 CL I ZN 0 AEx ia IIB T4 For connection to CL I/II/III DIV1 GP ABCDEFG CL I ZN 0 AEx ia IIC T4 Enclosure: IP66, Type 4X Ambient temperature: $-40\text{ °C} \leq T_a \leq +70\text{ °C}$ Electrical Parameters: Wireless Communication (Connector) $U_o = 5.88\text{ V}$, $I_o = 483\text{ mA}$, $P_o = 779\text{ mW}$, $C_o = 5.82\text{ }\mu\text{F}$, $L_o = 25\text{ }\mu\text{H}$ Sensor Input (Terminal 1 to 4) $U_o = 5.88\text{ V}$, $I_o = 145\text{ mA}$, $P_o = 213\text{ mW}$, $C_o = 43\text{ }\mu\text{F}$, $L_o = 1.6\text{ mH}$ Sensor Output (Terminal 5, 6)*1 $U_i = 30\text{ V}$, $I_i = 200\text{ mA}$, $P_i = 1\text{ W}$ (linear source), $C_i = 10\text{ nF}$, $L_i = 0\text{ }\mu\text{H}$ Dielectric Strength: $\geq 500\text{ V AC}$, r.m.s., 1 min	FS17
	Canada	FM Intrinsically safe Approval (Canada) Applicable Standards: CAN/CSA-C22.2 No.0 CAN/CSA-C22.2 No. 60079-0 CAN/CSA-C22.2 No. 60079-11 CAN/CSA-C22.2 No. 61010-1 CAN/CSA-C22.2 No. 94.1 CAN/CSA-C22.2 No. 94.2 CAN/CSA-C22.2 No. 60529 Specific Ex marking: Ex ia [ia IIC] IIB T4 Ga IS CL I/II/III DIV1 GP CDEFG T4 For connection to CL I/II/III GP DIV1 ABCDEFG Enclosure: IP66, Type 4X Ambient temperature: $-40\text{ °C} \leq T_a \leq +70\text{ °C}$ Electrical Parameters: Wireless Communication (Connector) $U_o = 5.88\text{ V}$, $I_o = 483\text{ mA}$, $P_o = 779\text{ mW}$, $C_o = 5.82\text{ }\mu\text{F}$, $L_o = 25\text{ }\mu\text{H}$ Sensor Input (Terminal 1 to 4) $U_o = 5.88\text{ V}$, $I_o = 145\text{ mA}$, $P_o = 213\text{ mW}$, $C_o = 43\text{ }\mu\text{F}$, $L_o = 1.6\text{ mH}$ Sensor Output (Terminal 5, 6)*1 $U_i = 30\text{ V}$, $I_i = 200\text{ mA}$, $P_i = 1\text{ W}$ (linear source), $C_i = 10\text{ nF}$, $L_i = 0\text{ }\mu\text{H}$ Dielectric Strength: $\geq 500\text{ V AC}$, r.m.s., 1 min	CS17
ATEX		ATEX Intrinsically safe Approval Applicable Standards: EN IEC 60079-0, EN 60079-11, EN 60079-28 Certificate number: FM15ATEX0071X Specific Ex marking: II 1G Ex ia op is [ia IIC] IIB T4 Ga Degrees of protection: IP66 in accordance with only IEC 60529 Amb. Temp. (Tamb): $-40\text{ to }70\text{ °C}$ ($-40\text{ to }158\text{ °F}$) Electrical Parameters: Wireless Communication (Connector) $U_o = 5.88\text{ V}$, $I_o = 483\text{ mA}$, $P_o = 779\text{ mW}$, $C_o = 5.82\text{ }\mu\text{F}$, $L_o = 25\text{ }\mu\text{H}$ Sensor Input (Terminal 1 to 4) $U_o = 5.88\text{ V}$, $I_o = 145\text{ mA}$, $P_o = 213\text{ mW}$, $C_o = 43\text{ }\mu\text{F}$, $L_o = 1.6\text{ mH}$ Sensor Output (Terminal 5, 6)*1 $U_i = 30\text{ V}$, $I_i = 200\text{ mA}$, $P_i = 1\text{ W}$ (linear source), $C_i = 10\text{ nF}$, $L_i = 0\text{ }\mu\text{H}$ Dielectric Strength: $\geq 500\text{ V AC}$, r.m.s., 1 min	KS27

Item	Description	Code
IECEX	IECEx Intrinsicly safe Approval Applicable Standards: IEC60079-0, IEC60079-11, IEC60079-28 Certificate number: IECEx FMG 15.0042X Specific Ex marking: Ex ia op is [ia IIC] IIB T4 Ga Degrees of protection: IP66 in accordance with only IEC 60529 Amb. Temp. (Tamb): -40 to 70 °C (-40 to 158 °F) Electrical Parameters: Wireless Communication (Connector) Uo = 5.88 V, Io = 483 mA, Po = 779 mW, Co = 5.82 µF, Lo = 25 µH Sensor Input (Terminal 1 to 4) Uo = 5.88 V, Io = 145 mA, Po = 213 mW, Co = 43 µF, Lo = 1.6 mH Sensor Output (Terminal 5, 6)*1 Ui = 30 V, Ii = 200 mA, Pi = 1 W (linear source), Ci = 10 nF, Li = 0 µH Dielectric Strength: ≥ 500 V AC, r.m.s., 1 min	SS27

*1: If Measurement code C is selected, Terminal 5 and 6 are not applicable.

■ OPTIONAL SPECIFICATIONS

Item	Description	Code
Protection cap *	Metal waterproof cap	CP
Wired tag plate	316 SST tag plate wired onto module	N4

*: When protection cap is not specified, dust-cap is attached.

■ OPTIONAL ACCESSORIES

Item	Parts Number	Description
Battery pack assembly	F9090FD *1	Battery case, Lithium-thionyl chloride batteries *2 2 pieces
Batteries *3	F9915NR	Lithium-thionyl chloride batteries *2, 2pieces
Battery case	F9090GD *4	Battery case only
Magnet	F9840PA	For magnet switch operation

*1: If you need F9090FC, please purchase F9090FD. F9090FD is a set of F9090FC and instruction manual.

*2: Tadiran TL-5930/S

*3: Alternatively, Tadiran SL-2780/S, TL-5930/S or VITZROCELL SB-D02 batteries can be purchased from your local distributor.

*4: If you need F9090GC, please purchase F9090GD. F9090GD is a set of F9090GC and instruction manual.

■ DIMENSIONS

□ 2-inch pipe mounting (for horizontal piping)

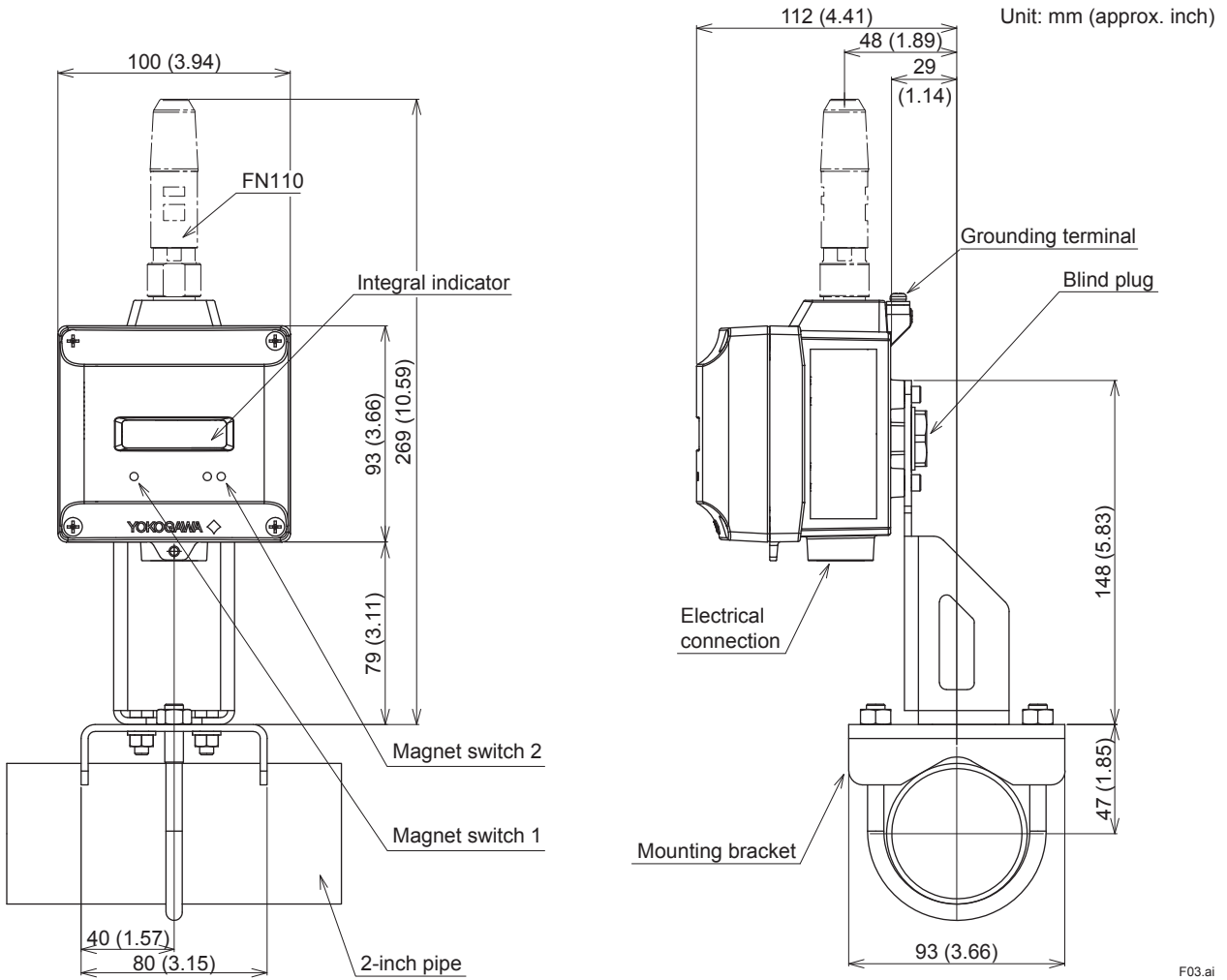

F03.ai

□ 2-inch pipe mounting (for vertical piping)

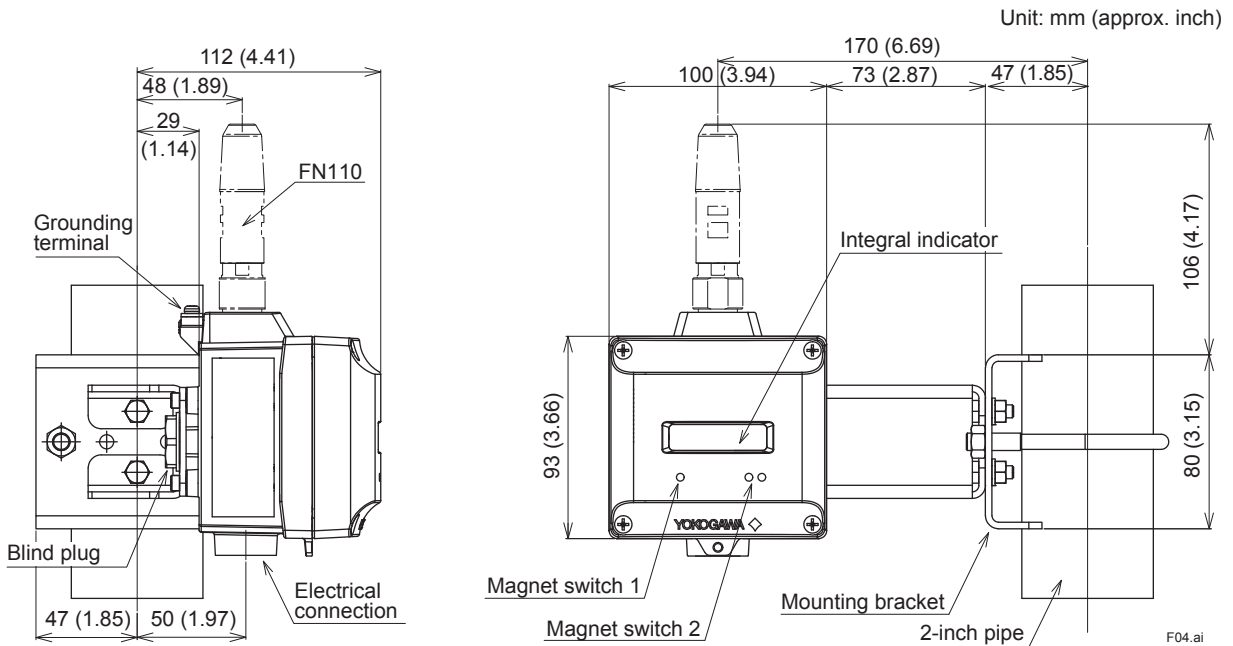

● Infrared Configuration

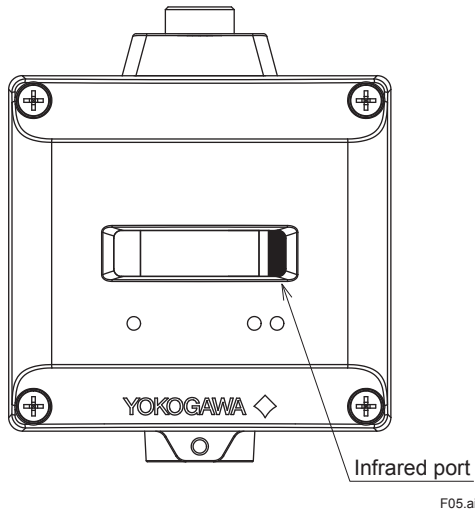

● Pin Assignment of FN110 Connection Terminal

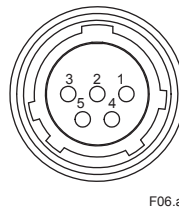

Pin	Signal
1	Frame Ground*
2	Signal Ground
3	Power Supply
4	Transmit/Receive Data positive
5	Transmit/Receive Data negative

* Wired to the grounding terminal inside the FN510 housing.

● Input Terminal Configurations

[Measurement code: A]

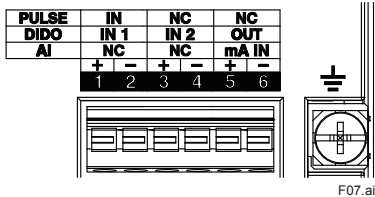

Terminal	Signal		
	AI	DIDO	PULSE
1	No Connection	Input Signal1 +	Input Signal +
2	No Connection	Input Signal1 -	Input Signal -
3	No Connection	Input Signal2 +	No Connection
4	No Connection	Input Signal2 -	No Connection
5	Input Signal +	Output Signal +	No Connection
6	Input Signal -	Output Signal -	No Connection
⏏	Frame Ground		

[Measurement code: C]

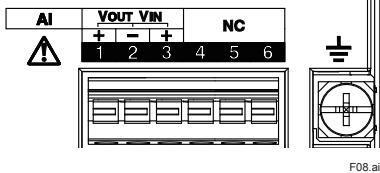

Terminal	Signal
	AI
1	Power Supply +
2	Power Supply GND and Input Signal -
3	Input Signal +
4	No Connection
5	No Connection
6	No Connection
⏏	Frame Ground

• Input Wiring

[Measurement code: A]

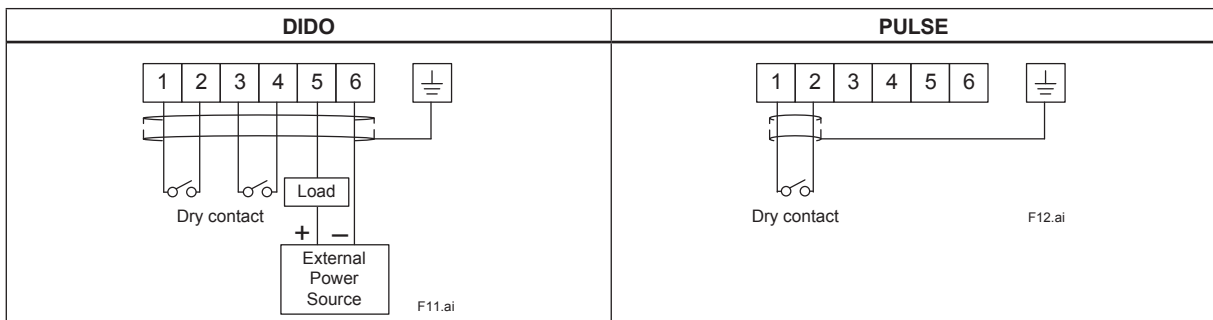
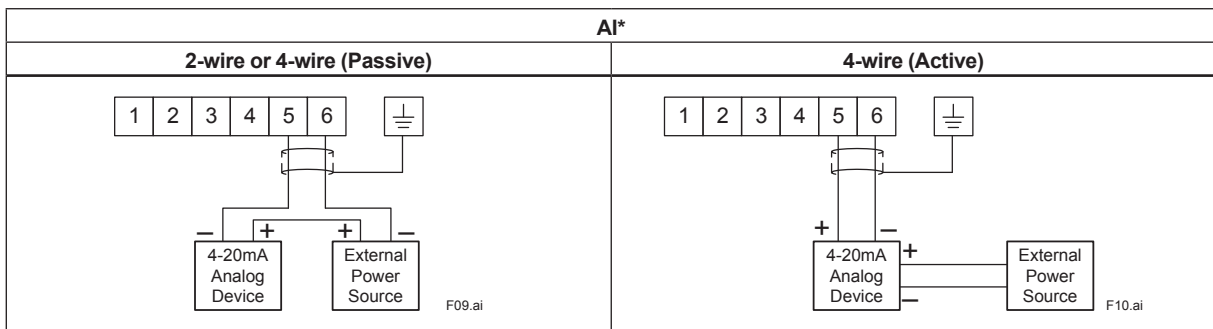

[Measurement code: C]

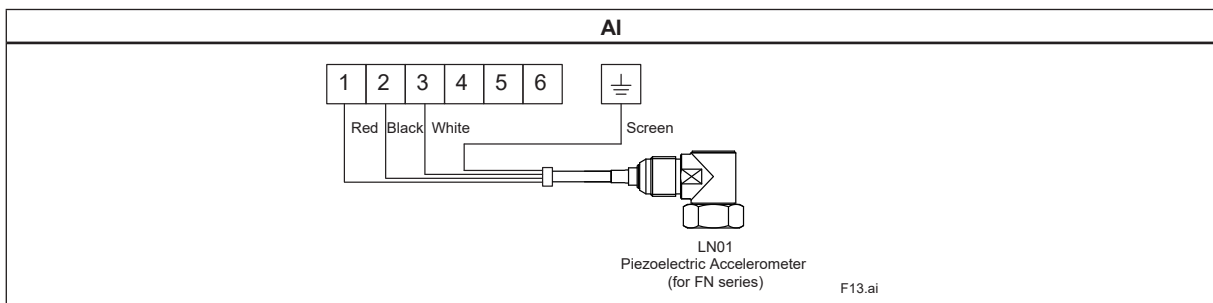

< Ordering Information >

Specify the following when ordering.

1. Model, suffix codes, and option codes.
2. Tag Number (if required)
Engraving on the tag plate can be specified by a combination of uppercase letters, lowercase letters, numbers, “- (hyphen)”, “_ (underscore)”.
Factory setting is blank unless otherwise specified.

< Trademark >

All brand or product names of Yokogawa Electric Corporation in this document are trademarks or registered trademarks of Yokogawa Electric Corporation.

All other company brand or product names in this document are trademarks or registered trademarks of their respective holders.

In this document, trademarks or registered trademarks are not marked with “™” or “®”.

< Related Products General Specifications >

- Field Wireless System Overview:
Refer to GS 01W01A01-01EN
- Field Wireless Communication Module FN110:
Refer to GS 01W03B01-01EN
- LN01 Piezoelectric Accelerometer (for FN series):
Refer to GS 01W03H01-01EN
- Field Wireless Management Station YFGW410:
Refer to GS 01W02D01-01EN
- Field Wireless Access Point YFGW510:
Refer to GS 01W02E01-01EN
- Field Wireless Access Point YFGW520:
Refer to GS 01W02E02-01EN
- FieldMate Versatile Device Management Wizard:
Refer to GS 01R01A01-01E
- Plant Resource Manager (PRM):
Refer to GS 30B05A10-01EN

< Information on WEEE Directive >

EU WEEE (Waste Electrical and Electronic Equipment) Directive is only valid in the EU. This instrument is intended to be sold and used only as a part of equipment which is excluded from WEEE Directive, such as large-scale stationary industrial tools, a large-scale fixed installation and so on, and, therefore, subjected to the exclusion from the scope of the WEEE Directive. The instrument should be disposed of in accordance with local and national legislation/regulations.