

High pressure valves

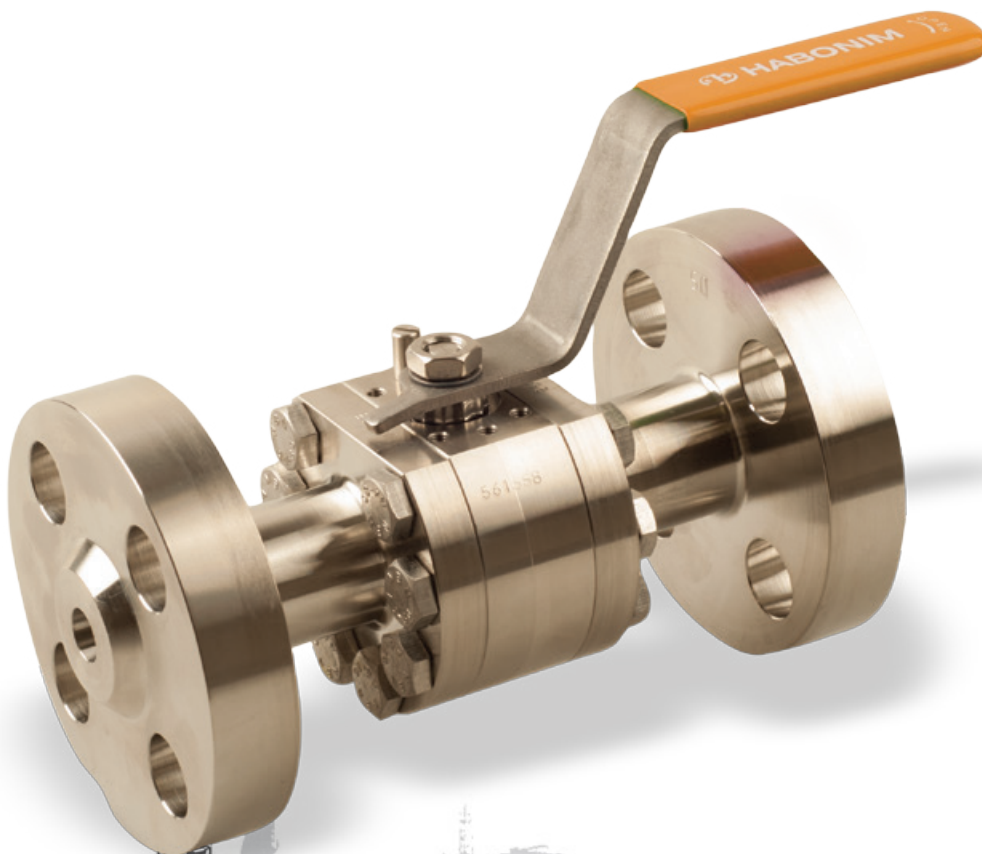

Introduction

The Habonim high pressure valve series is based on a floating ball valve technology, specially built for endurance and reliability with a design pressure of up to ANSI Class 2500 (414 bar / 6000 psi). As standard, the high pressure series is made from forged or rolled bar material. Consequently we are able to 'sculpture' the valve to customer specific demands in a very short time.

The result is a cost effective solution compared with trunnion mounted ball valve technology. The high pressure valve series delivers reliable performance in the most demanding applications in the oil & gas, offshore drilling platform, petrochemical and the power industries.

The 28 series with size up to and including 2" (DN50) is capable of operation under full Class 2500 differential pressure, providing smooth and trouble free functionality. For sizes 2½" (DN65) and above the 28 series with hybrid seats can handle differential pressure of up to 255 bar (3700 psi).

The pressure containing parts are in compliance with ASME B16.34, for wall thickness, the design successfully passed burst testing according to DNV rules, i.e. holding four times the pressure rating for 5 minutes. A one-size-up stem made of high tensile material complies with ASME B16.34 and API 6D for drive train requirements provides sufficient safety factor during operation. A special hybrid seat design is comprised of a metal housing and polymer insert machined as a single unit. This provides higher metal seat stiffness and bubble tight shut-off (Rate A) combined with lower operating torque compared to any equivalent valve solution.

The 27 series is a cost effective solution compared with the 28 series, The 27 series with size up to and including 2" (DN50) is capable of operation under full Class 2500 differential pressure, providing smooth and trouble free functionality.

For sizes 2½" (DN65) and above the 27 series can handle differential pressure of up to 70 bar (1015 psi).

The 24 series is part of the Habonim high pressure instrumentation line, a two-piece design, in sizes up to 1½" (DN40). The 24 series are designed for shutoff against full differential pressure of 414 bar (6000 psi).

The 24 series is DNV certified, having successfully passed burst testing as well as fire safe testing to API 607 and ISO 10497. By default the valve is manually operated, automation is available upon request.

Technical summary

Size range	¼"-8" (DN8-DN200)
Series in range	28 series ANSI B16.34 class 2500 (wall thickness), size ¼"-8" (DN8-DN200)
	27 series ANSI B16.34 class 2500 (wall thickness), size ¼"-2" (DN8-DN50) ANSI B16.34 class 1500 (wall thickness), size 2½"-8" (DN65-DN200)
	24 series Class 2500, size ¼"-1½" (DN8-DN40)
Temperature range	-60 °C to +260 °C (-76 °F to +500 °F)
Materials	Stainless Steel 316/316L, Carbon Steel ASTM A350 LF2 , C.St A105 and more.
End connections	Threaded, welded, flanged

Standards of compliance

Factory certification	ISO 9001-2008	Quality management system
Valve design and tests	ANSI B16.34, API 6D / ISO 14313, ISO 17292 ANSI B1.20.1 EN 10226-1, ISO 7-1, JIS B0203 DIN 3852 NACE MR-0175, ISO 15156-1/2/3 EN 12266-1, API 598 API 607, ISO 10497 ISO 15848-1	Valve design NPT - National Pipe Taper thread BSPT - British Standard Pipe Taper thread BSPP - British Standard Paralell Pipe Materials for use in H ₂ S-containing environments in oil and gas production Testing of metallic valves - pressure tests, test procedures and acceptance criteria Testing of valves - fire type-testing requirements
Certifications	PED 97/23/EC, PED 2014/68/EU Module H ATEX 94/9/EC IEC 61508-2 SIL 2/3	Industrial valves - measurement, test and qualification procedures for fugitive emissions Pressure equipment directive Equipment and protective systems intended for use in potentially explosive atmospheres (optional for actuated unit only) Safety integrity level - functional safety of electrical/electronic/programmable electronic safety-related systems (optional for actuated unit only)
Documentation	EN 10204 2.2 / 3.1 / 3.2	Metallic materials - types of inspection documents

24 Series design features

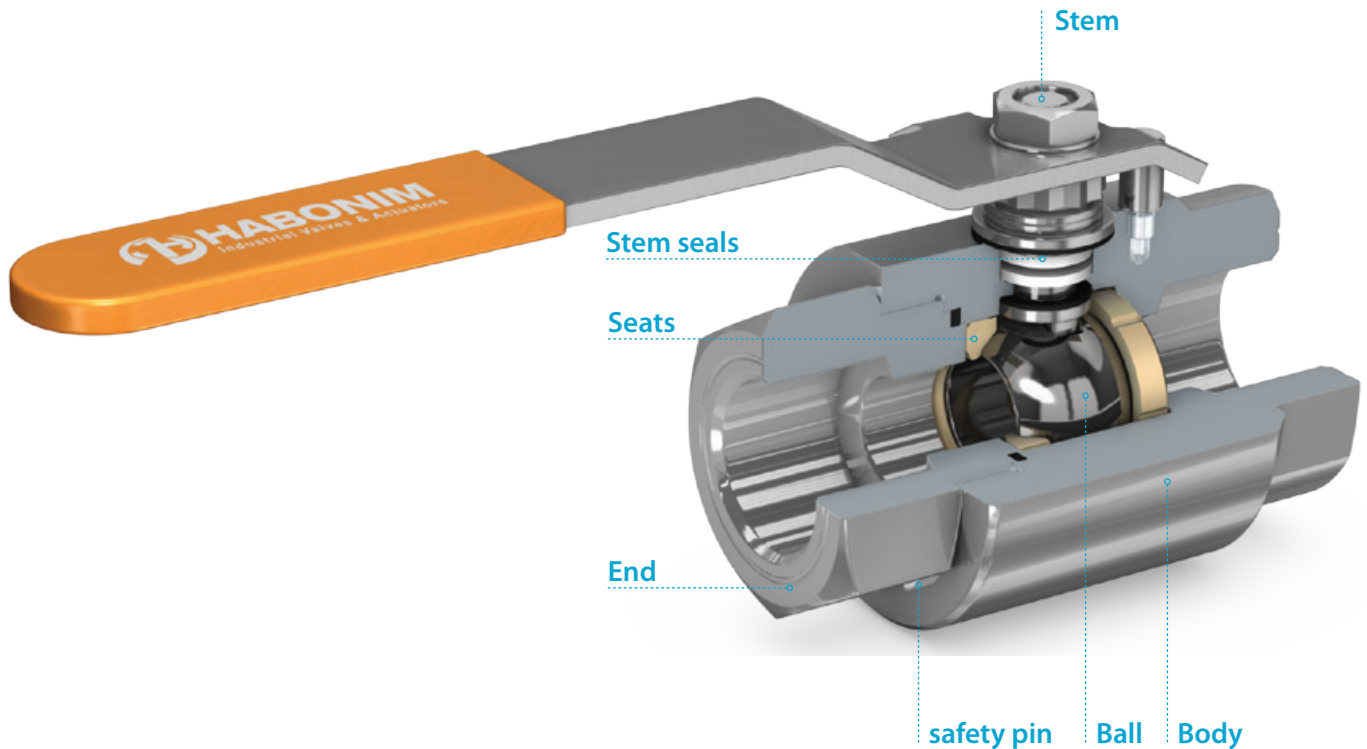

Body

- Two piece design - minimum leak paths
- Threaded body - end connection
- Robust high pressure design
- Full compliance with B16.34 and API 6D
- Carbon steel valves are oxidized to MIL-DTL-13924 standard or available in epoxy paint finish upon request
- Stainless steel and high alloy valves provided with natural finish
- Safety pin eliminates unintentional rotation of end connection

Ball

- Mirror polished
- Solid ball
- Pressure equalizing hole in the stem slot
- 17-4PH high tensile ball for 1/4"-3/4" DN8-DN20 valves (standard)

Stem

- One pcs solid stem
- 17-4PH high tensile valve stem (standard)
- Anti blowout proof design
- Anti-static device
- Fire-lip

Stem seal

- ISO 15848-1 certified
- High endurance up to hundreds of thousands of cycles
- Non-graphite fire safe certified stem seal
- Anti-abrasion mechanism
- Live loaded

Seats and seals

- Adapted for high pressure seats
- Shore 90 hardness O-ring seals
- Rate A leakage tightness
- Variety of materials

Operation

- The 24 series are designed for shutoff against full differential pressure of 414 bar (6000 psi)
- Automation is available upon request

Floating Ball Valves

High pressure

General

24 Series

27 Series

28 Series

Ordering code system

27 Series design features

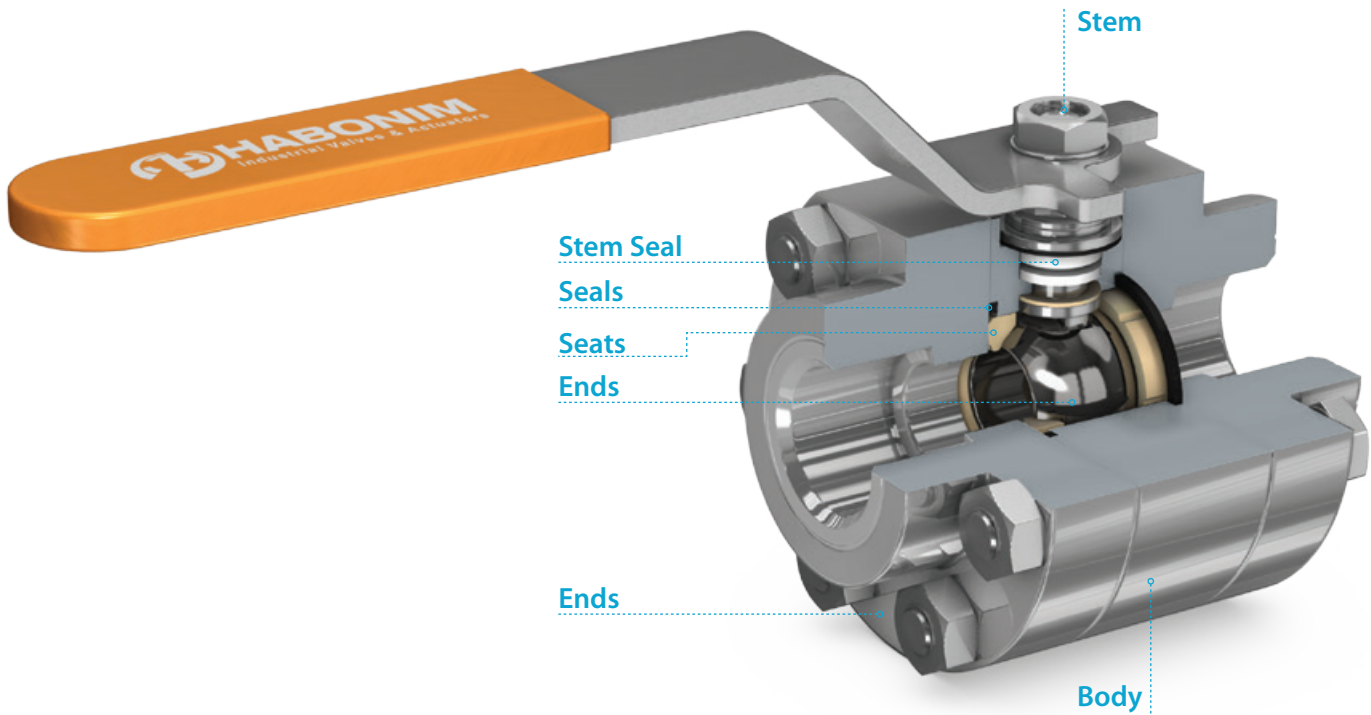

Body

- Three-piece in-line design for easy repair
- Various types of end connections available
- Robust high pressure design
- Wall thickness compliant with B16.34
- Carbon steel valves are oxidized to MIL-DTL-13924 standard or available in epoxy paint finish upon request
- Stainless steel and high alloy valves provided with natural finish

Ball

- Mirror polished
- Solid ball
- Pressure equalizing hole in the stem slot
- 17-4PH high tensile ball for 1/4"-3/4" (DN8-DN20) valves (standard)

Stem

- One piece solid stem
- 17-4PH high tensile valve stem (standard)
- Anti blowout proof design
- Anti-static device
- Fire-lip

Stem seal

- ISO 15848-1 certified
- High endurance up to hundreds of thousands of cycles
- Non-graphite firesafe certified stem seal
- Anti-abrasion mechanism
- Live loaded

Seats and seals

- Adapted for high pressure seats
- Shore 90 hardness O-ring seals
- Rate A leakage tightness
- Variety of materials

Operation

- The 27 series, Size 1/4"-2" (DN8-DN50) is designed for breakout to open under maximum differential pressure of class 2500
- Size 2 1/2"-8" (DN65-DN200) is designed for breakout to open under maximum differential pressure of 70 bar (1015 psi)

28 Series design features

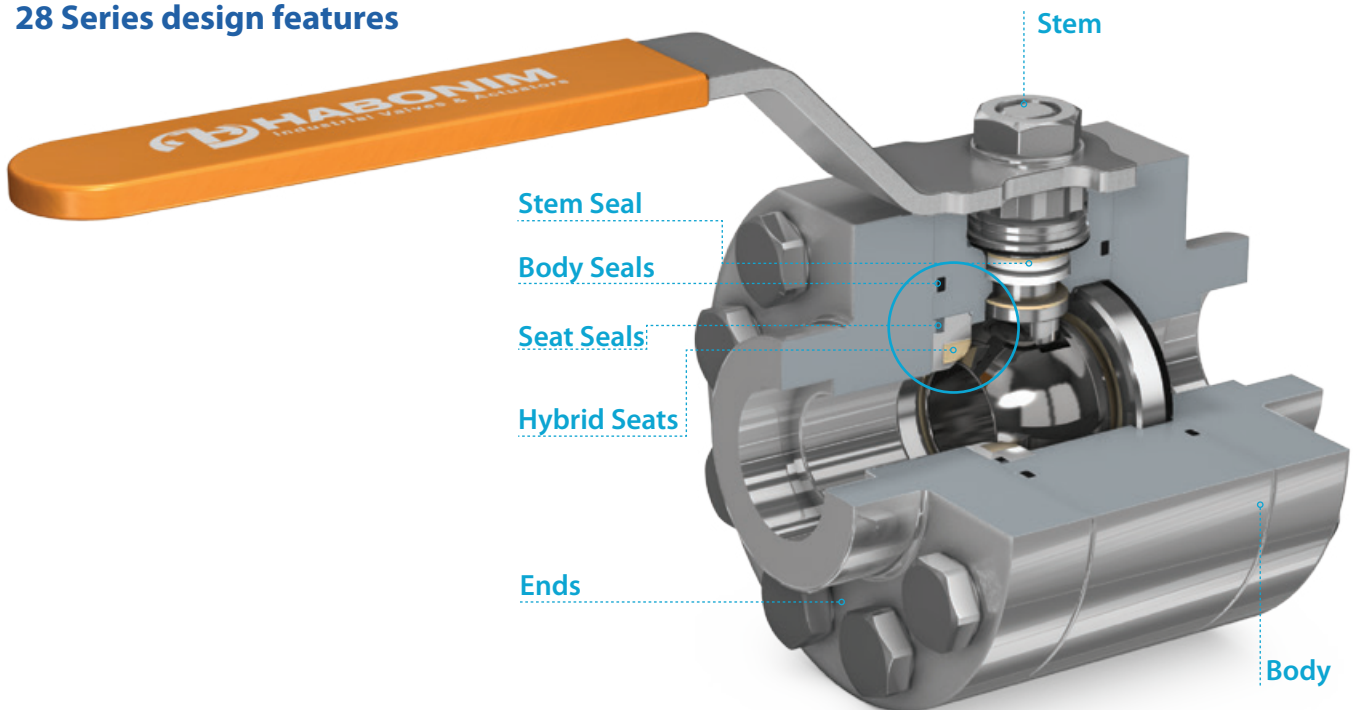

Standard design

Two seals of the same material: PTFE, graphite, NBR, Viton
 Valve code example:
 10 F28W-666MWG/NPT
G - for two graphite seals

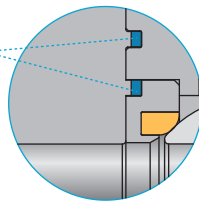

Optional design

One body seal: PTFE, graphite, NBR, Viton
 Two O-ring seat seals: NBR Viton
 Valve code example:
 10 F28W-666MWG/NPT-UV
G - for graphite body seal
UB or **UV** suffix to the ordering code for NBR or Viton seat seals

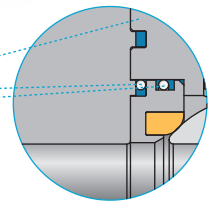

Body

- Three-piece in-line design for easy repair
- Various types of end connections available
- ISO 5211 pad for standard instrumentation attachment
- Robust high pressure design
- Full compliance with B16.34 and API 6D for class #1500 (including bolts), wall thickness compliant for #2500
- Carbon steel valves are oxidized to MIL-DTL-13924 standard or available in epoxy paint finish upon request
- Stainless steel and high alloy valves provided with natural finish

Ball

- Mirror polished
- Solid ball
- Pressure equalizing hole in the stem slot
- 17-4PH high tensile ball for ¼"-¾" (DN8-DN20) valves (standard)

Stem

- One-piece solid oversized stem to accommodate high torques
- 17-4PH high tensile valve stem (standard)
- Blowout-proof design
- Anti-static device
- Fire-lip

Stem seal

- ISO 15848-1 certified
- High endurance up to hundreds of thousands of cycles
- Non-graphite firesafe certified stem seal
- Anti-abrasion mechanism
- Live loaded

Seats and seals

- Hybrid seats for high pressure durability
- Double sealed body
- Shore 90 hardness for O-ring seals
- Optional second O-ring seal
- Rate "A" leakage tightness
- Variety of high rigidity polymers for insert materials

Operation

- The 28 series, Size ¼"-2" (DN8-DN50) is designed for breakout to open under maximum differential pressure of class 2500
- Size 2 ½"-6" (DN65-DN150) is designed for breakout to open under maximum differential pressure of class 1500.

Floating Ball Valves

High pressure

General

24 Series

27 Series

28 Series

Ordering code system

Size 1/4" - 1 1/2" | DN8-DN40 | Class 2500 | 24X/24W/24⁽¹⁾ Series

Valve dimensions

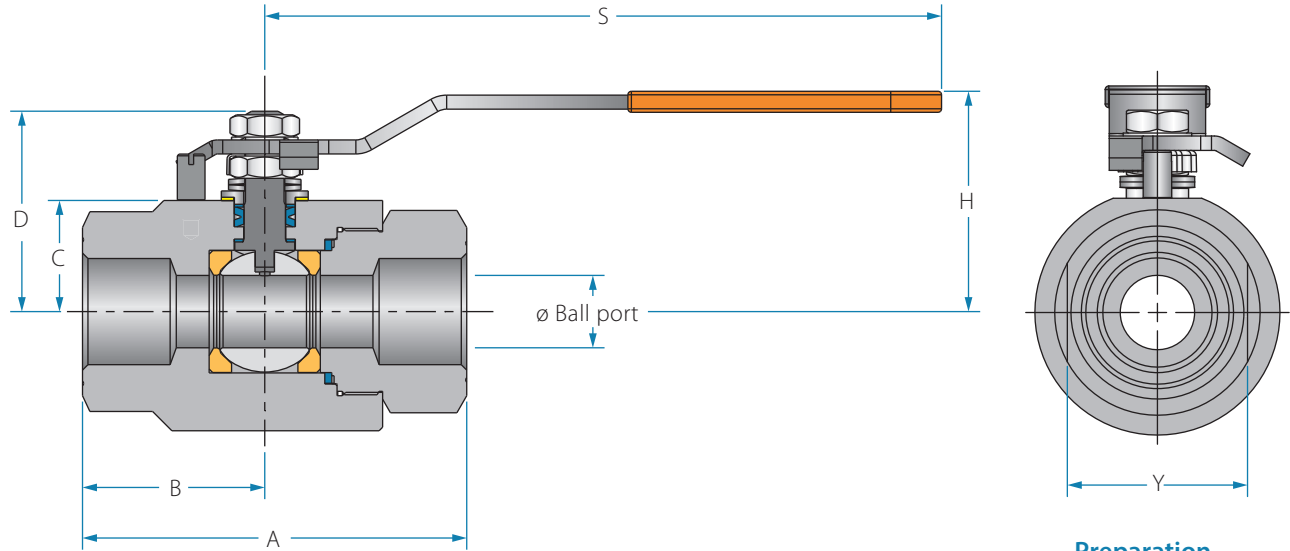

Preparation for actuation

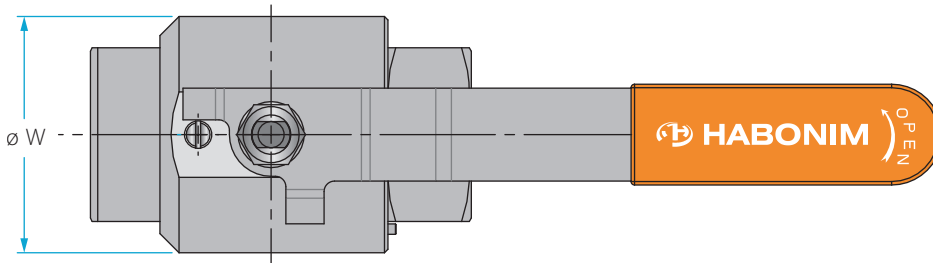
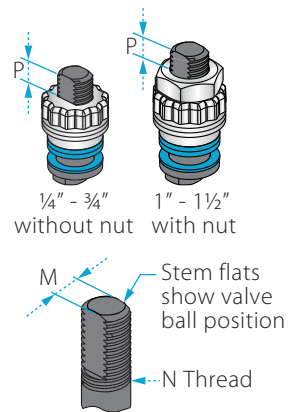

Std. port	Unit	Ball port	A	B	C	D	H	M	N	P	ØW	S	Y	weight kg/lb	kv cv
DN8	mm	11.15	83.30	40.00	20.5	37.90	42.10	5.54	3/8" UNF	11.10	49.00	179.00	30.00	0.80	2.6
1/4"	inch	0.44	3.28	1.57	0.81	1.49	1.66	218.00		0.43	1.93	7.05	1.18	1.76	3.0
DN10	mm	11.15	83.30	40.00	20.5	37.90	42.10	5.54	3/8" UNF	11.10	49.00	179.00	30.00	0.80	4.3
3/8"	inch	0.44	3.28	1.57	0.81	1.49	1.66	218.00		0.43	1.93	7.05	1.18	1.76	5.0
DN15	mm	11.15	83.30	40.00	20.50	37.90	42.10	5.54	3/8" UNF	11.10	49.00	179.00	30.00	0.80	6.9
1/2"	inch	0.44	3.28	1.57	0.81	1.49	1.66	218.00		0.43	1.93	7.05	1.18	1.76	8.0
DN20	mm	14.30	90.00	42.00	23.50	40.30	45.00	5.54	3/8" UNF	11.10	54.00	179.00	40.00	1.27	10
3/4"	inch	0.56	3.54	1.65	0.93	1.59	1.77	0.21		0.43	2.13	7.05	1.57	2.79	12
DN25	mm	20.60	109.60	52.00	30.50	55.60	60.30	7.54	7/16" UNF	15.40	68.00	193.00	50.00	2.10	28
1"	inch	0.81	4.31	2.05	1.20	2.19	237.00	0.29		0.60	2.68	7.60	1.97	4.63	32
DN32	mm	25.40	117.70	55.00	35.50	60.20	68.70	7.54	7/16" UNF	15.40	79.00	193.00	60.00	2.90	49
1 1/4"	inch	1.00	4.65	2.17	1.39	237.00	27.00	0.29		0.60	3.11	7.60	2.36	6.39	57
DN40	mm	31.80	135.00	63.00	42.50	73.00	81.10	8.70	9/16" UNF	19.60	89.00	287.00	70.00	4.80	69
1 1/2"	inch	1.50	5.31	2.48	1.67	2.87	3.19	0.34		0.77	3.50	11.30	2.76	10.58	80

Components & materials

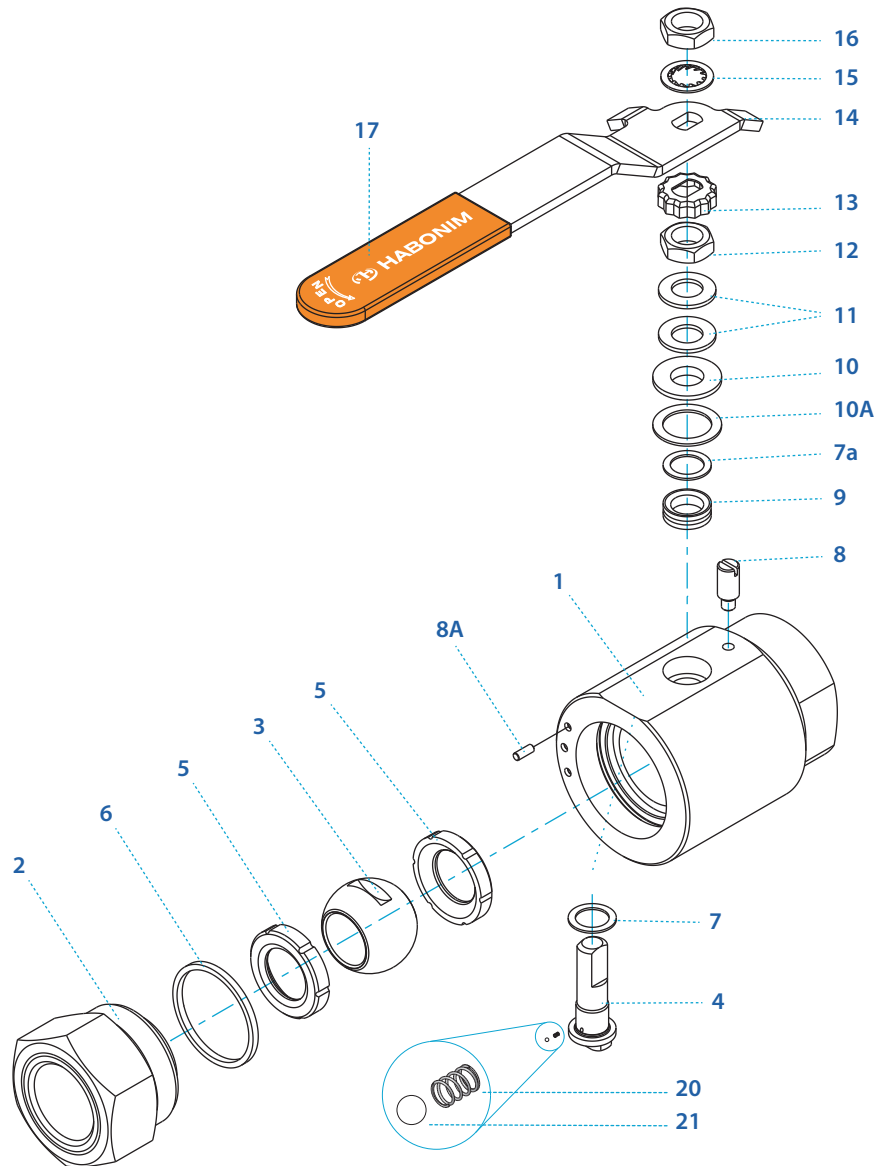

Item	Description	Material specification	Qty.
1	Body	S.St. A479 316/316L, C.St. A350 LF2, C.St A105, B473 N08020 (Alloy 20), B164 N04400 (Monel 400), B574 N06022 (Alloy C22), B574 N10276 (Alloy C276), A479 S31254 (254 SMO), A479 S31803 (Duplex), A479 S32750 (Super Duplex)	1
2	End	A479 316/316L, A350 LF2, C.St A105, B473 N08020, B164 N04400, B574 N06022, B574 N10276, A479 S31254, A479 S31803, A479 S32750	1
3	Ball	S.St for 1/2" and 3/4" valves: A564 Gr.630 H1150D 17-4PH, S.St for 1" and up valves: A351 CF8M, A479 316/316L, B473 N08020, B164 N04400, B574 N06022, B574 N10276, A479 S31254, A479 S31803, A479 S32750, B637 UNS-N07718 (Inconel 718)	1
4	Stem	A564 Gr.630 H1150D 17-4PH, B164 N04400, B574 N06022, A479 S31803, A479 S32750, B637 UNS-N07718 (Inconel 718)	1
5*	Seat	PVDF, DELRIN, PEEK, CF PEEK, PCTFE (KEL-F)	2
6*	Body seal	PTFE, Graphite, NBR, Viton	1
7*	Stem thrust seal	PEEK, CF PEEK, PCTFE (KEL-F), TFM ⁽²⁾ , CF PTFE ⁽²⁾	1

Item	Description	Material specification	Qty.
7a**	Anti-abrasion ring	PEEK, CF PEEK, PCTFE (KEL-F), TFM ⁽²⁾ , CF PTFE ⁽²⁾	1
8	Stop pin	A582 303	1
9*	Stem seal	CF PTFE, TFM, Graphite ⁽²⁾	1
10	Follower	B783 316L	1
10A*	Slide bearing	TF316	1
11	Disc spring	A693 631 17-7PH	2
12	Stem nut	A194 8M, EN3506-2 A4-80	1
13	Locking clip	A167 304	1
14	Handle	C.St. A29 G10200 Zinc plate, S.St. A240 430	1
15	Serrated washer	A240 410	1
16	Handle nut	A194 8M, EN3506-2 A4-80	1
17	Sleeve	PVC	1
20	Anti static spring	A313 302	1
21	Anti-static plunger	A479 304	1
23	Tag (not shown)	A167 304	1

* Repair kit components

** Only with HermetiX™ stem seal. Does not supplied in 1/2" and 3/4" valves

⁽¹⁾ 24 Series is Habonim's standard valve design without the HermetiX™ stem seal construction

⁽²⁾ This material can only be used as part of non HermetiX™ design

Floating Ball Valves

High pressure

General

24 Series

27 Series

28 Series

Ordering code system

Size 1/4"- 2" | DN8-DN50 | Class 2500 | 27X/27W/27⁽¹⁾ Series

Valve dimensions

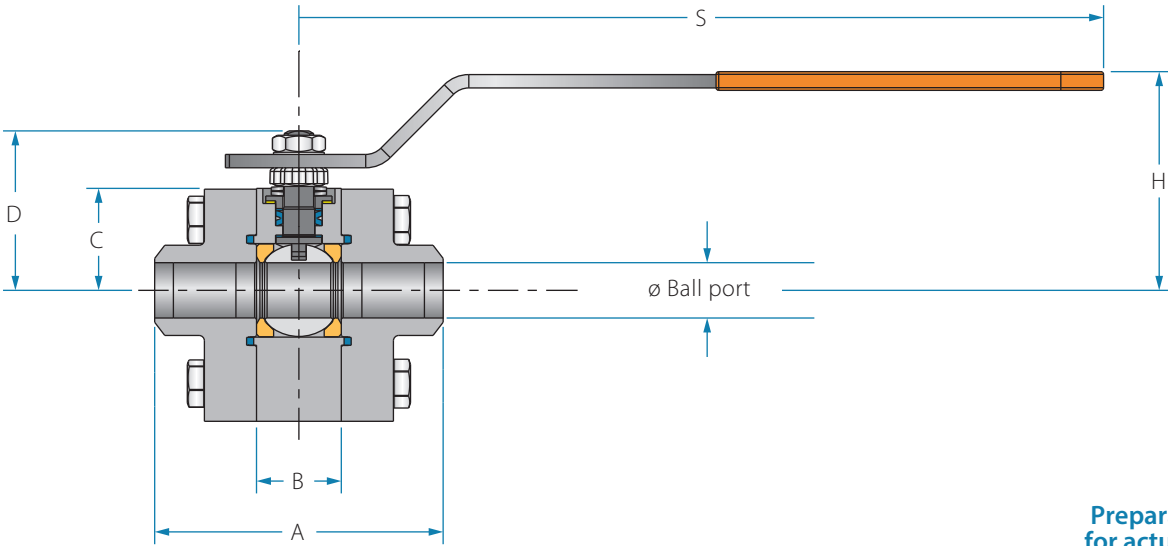

Preparation for actuation

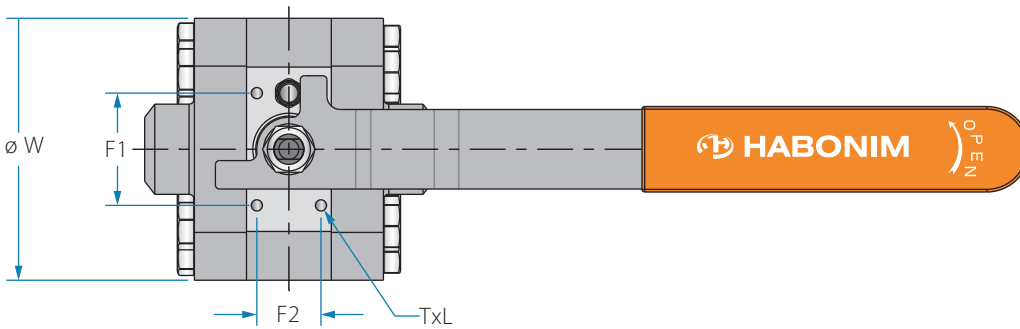
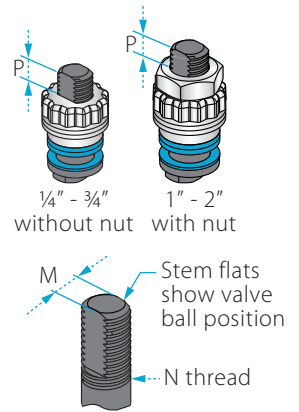

Std. port	Unit	Ball port	A	B	C	D	ØW	H	M	N	P	S	TxL	F1	F2	weight kg/lb	kv cv
DN8	mm	11.10	77.80	20.60	27.00	38.00	69.50	46.00	5.50	3/8" UNF	7.00	179.00	M5x8	34.00	0.00	1.60	2.6
1/4"	inch	0.44	3.06	0.81	1.06	1.50	2.74	1.81	0.22		0.28	7.05		1.34	0.00	3.50	3.0
DN10	mm	11.10	77.80	20.60	27.00	38.00	69.50	46.00	5.50	3/8" UNF	7.00	179.00	M5x8	34.00	0.00	1.60	4.3
3/8"	inch	0.44	3.06	0.81	1.06	1.50	2.74	1.81	0.22		0.28	7.05		1.34	0.00	3.50	5.0
DN15	mm	11.10	77.80	20.60	27.00	38.00	69.50	46.00	5.50	3/8" UNF	7.00	179.00	M5x8	34.00	0.00	1.60	6.9
1/2"	inch	0.44	3.06	0.81	1.06	1.50	2.74	1.81	0.22		0.28	7.05		1.34	0.00	3.50	8.0
DN20	mm	14.30	85.00	24.60	29.40	40.40	79.00	48.00	5.50	3/8" UNF	7.00	179.00	M5x8	34.00	15.00	2.40	10
3/4"	inch	0.56	3.35	0.97	1.16	1.59	3.11	1.89	0.22		0.28	7.05		1.34	0.59	5.30	12
DN25	mm	20.60	107.90	31.80	38.20	55.70	98.00	64.00	7.54	7/16" UNF	7.00	192.00	M5x8	42.00	24.00	4.50	28
1"	inch	0.81	4.25	1.25	1.50	2.19	3.86	2.52	0.30		0.28	7.56		1.65	0.94	9.90	32
DN32	mm	25.40	120.70	41.20	38.20	60.30	109.00	68.70	7.54	7/16" UNF	7.00	192.00	M5x8	42.00	24.00	5.40	49
1 1/4"	inch	1.00	4.75	1.62	1.50	2.37	4.29	2.70	0.30		0.28	7.56		1.65	0.94	11.90	57
DN40	mm	31.80	131.20	48.40	50.00	72.80	128.00	81.10	8.71	9/16" UNF	10.00	287.00	M6x8	40.00	36.00	9.50	69
1 1/2"	inch	1.25	5.17	1.91	1.97	2.87	5.04	3.19	0.34		0.39	11.30		1.57	1.42	20.90	80
DN50	mm	38.20	142.90	56.30	55.00	77.80	145.00	81.10	8.71	9/16" UNF	10.00	287.00	M6x8	58.00	40.00	13.10	102
2"	inch	1.50	5.63	2.22	2.17	3.06	5.71	3.19	0.34		0.39	11.30		2.28	1.57	28.90	118

Components & materials

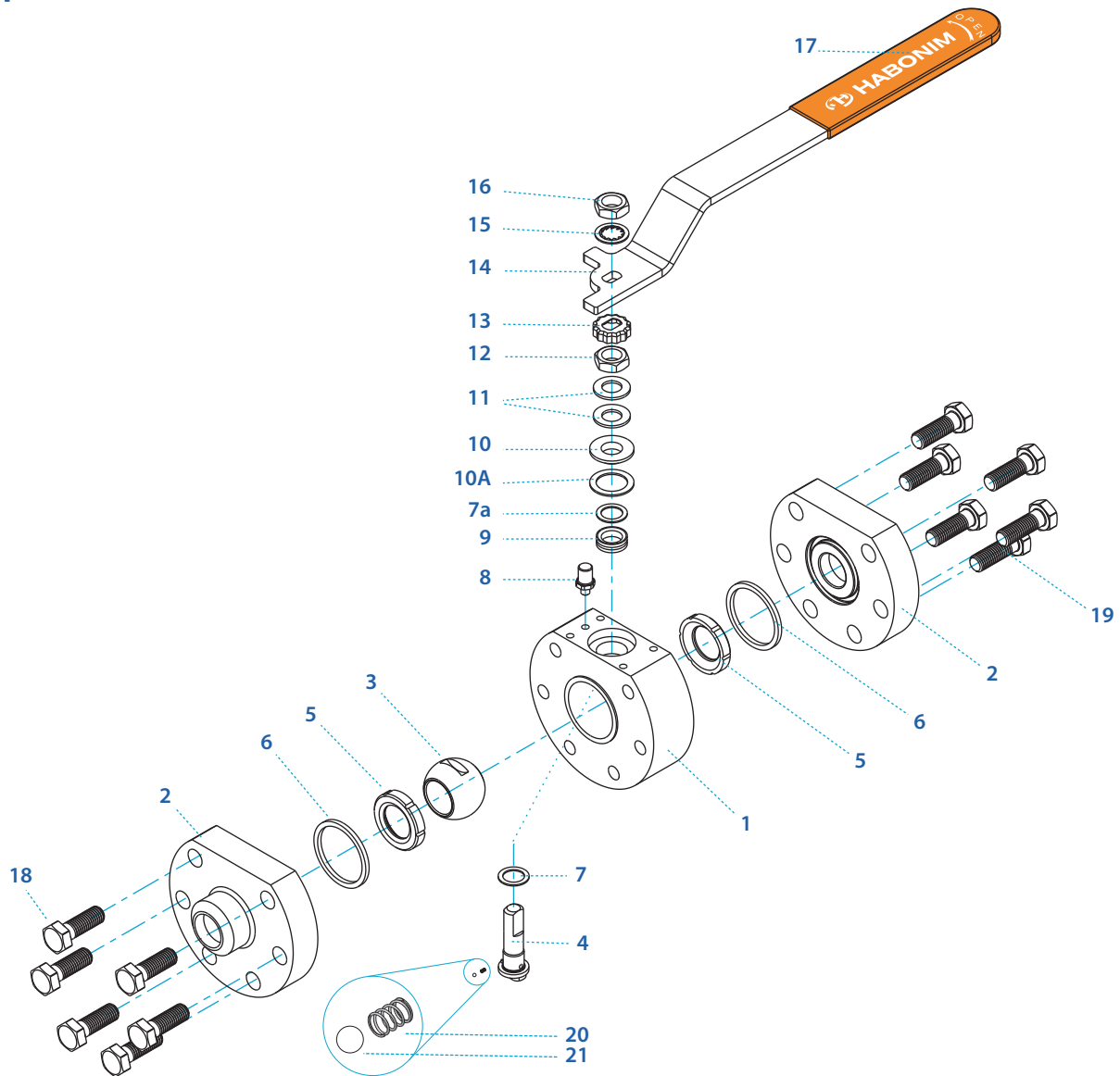

Item	Description	Material specification	Qty.
1	Body	S.St. A479 316/316L, C.St. A350 LF2, C.St A105, B473 N08020 (Alloy 20), B164 N04400 (Monel 400), B574 N06022 (Alloy C22), B574 N10276 (Alloy C276), A479 S31254 (254 SMO), A479 S31803 (Duplex), A479 S32750 (Super Duplex)	1
2	End	A479 316/316L, A350 LF2, C.St A105, B473 N08020, B164 N04400, B574 N06022, B574 N10276, A479 S31254, A479 S31803, A479 S32750	2
3	Ball	S.St for 1/2" and 3/4" valves: A564 Gr.630 H1150D 17-4PH, S.St for 1" and up valves: A351 CF8M, A479 316/316L, B473 N08020, B164 N04400, B574 N06022, B574 N10276, A479 S31254, A479 S31803, A479 S32750, B637 UNS-N07718 (Inconel 718)	1
4	Stem	A564 Gr.630 H1150D 17-4PH, B164 N04400, B574 N06022, A479 S31803, A479 S32750, B637 UNS-N07718 (Inconel 718)	1
5*	Seat	PVDF, DELRIN, PEEK, CF PEEK, PCTFE (KEL-F)	2
6*	Body seal	PTFE, Graphite, NBR, Viton	2
7*	Stem thrust seal	PEEK, CF PEEK, PCTFE (KEL-F), TFM ⁽²⁾ , CF PTFE ⁽²⁾	1

Item	Description	Material specification	Qty.
7a**	Anti-abrasion ring	PEEK, CF PEEK, PCTFE (KEL-F), TFM ⁽²⁾ , CF PTFE ⁽²⁾	1
8	Stop pin	A582 303	1
9*	Stem seal	CF PTFE, TFM, Graphite ⁽²⁾	1
10	Follower	B783 316L	1
10A*	Slide bearing	TF316	1
11	Disc spring	A693 631 17-7PH	2
12	Stem nut	A194 8M, EN3506-2 A4-80	1
13	Locking clip	A167 304	1
14	Handle	C.St. A29 G10200 Zinc plate, S.St. A240 430	1
15	Serrated washer	A240 410	1
16	Handle nut	A194 8M, EN3506-2 A4-80	1
17	Sleeve	PVC	1
18	Body bolts	A193 B8M, EN3506-1 A4-80	12-16
20	Anti static spring	A313 302	1
21	Anti static plunger	A479 304	1
23	Tag (not shown)	A167 304	1

* Repair kit components

** Only with HermetiX™ stem seal. Does not supplied in 1/2" and 3/4" valves

⁽¹⁾ 27 Series is Habonim's standard valve design without the HermetiX™ stem seal construction.

⁽²⁾ This material can only be used as part of non HermetiX™ design.

Floating Ball Valves

High pressure

General

24 Series

27 Series

28 Series

Ordering code system

Size 2½"- 8" | DN65-DN200 | Class 1500 | 27X/27W/27⁽¹⁾ Series

Valve dimensions

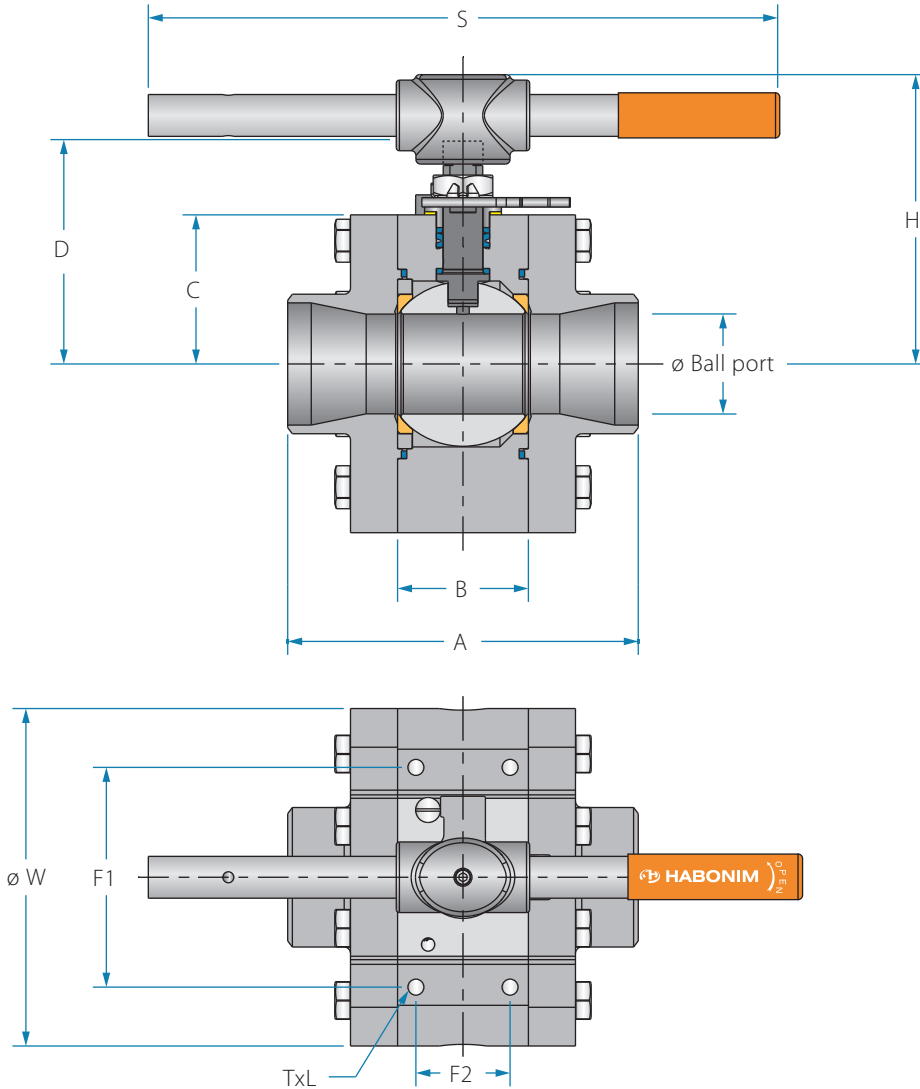

Preparation for actuation

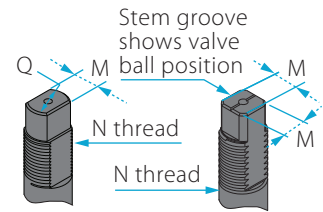
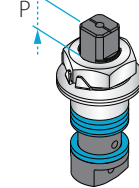

Special shape add WR to description (when ordering the valve)
Standard shape

Std. port	Unit	Ball port	A	B	C	D	ØW	H	M	M-DD	N	P	Q	S	TxL	F1	F2	Weight kg/lb	kv cv
DN65	mm	50.80	172.60	72.60	77.20	115.80	190.00	147.00	13.90	-	M20x2.5	16.50	-	256.00	M12x16	92.00	50.00	25.00	208
2½"	inch	2.00	6.80	2.86	3.04	4.56	7.48	5.79	0.55	-	M20x2.5	0.65	-	10.08	M12x16	3.62	1.97	55.10	241
DN80	mm	63.75	224.00	83.30	70.00	144.90	215.00	185.00	18.90	15.90	1"-14" UNS	16.60	22.70	402.00	M10x12	140.00	60.00	39.00	300
3"	inch	2.51	8.82	3.28	2.76	5.70	8.46	7.28	0.74	0.62	1"-14" UNS	0.65	0.89	15.83	M10x12	5.51	2.36	85.98	348
DN100	mm	82.70	268.00	108.80	90.00	160.70	250.00	201.00	18.90	15.90	1"-14" UNS	16.60	22.70	610.00	M10x12	150.00	70.00	64.00	615
4"	inch	3.26	10.55	4.28	3.54	6.33	9.84	7.91	0.74	0.62	1"-14" UNS	0.65	0.89	24.02	M10x12	5.91	2.76	141.10	713
DN150	mm	114.00	336.00	146.10	120.00	226.30	295.00	280.00	28.50	23.80	1½"-12" UNF	26.20	35.20	916.00	M16x18	140.00	66.00	120.00	872
6"	inch	4.49	13.23	5.57	4.72	8.91	11.61	11.02	1.12	0.94	1½"-12" UNF	1.03	1.39	36.06	M16x18	5.51	2.60	264.55	1012
DN200	mm	144.40	558.60	178.60	136.00	300.70	348.00	-	35.90	-	2"-8" UN-2A	58.00	-	-	M20x25	170.00	96.00	225.00	1552
8"	inch	5.69	21.99	7.03	5.35	11.84	13.70	-	1.41	-	2"-8" UN-2A	2.28	-	-	M20x25	6.69	3.78	496.04	1800

Components & materials

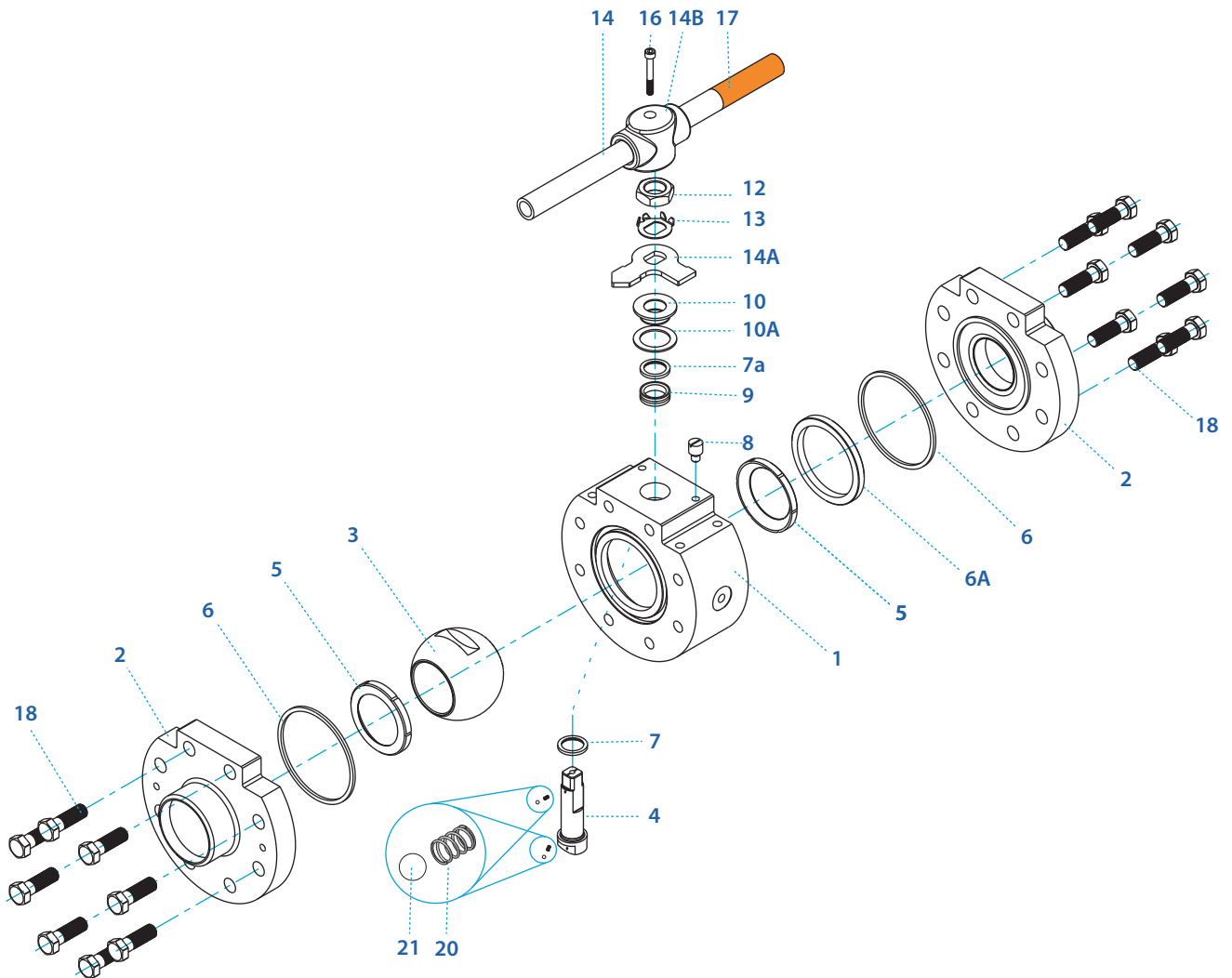

Item	Description	Material specification	Qty.
1	Body	S.St. A479 316/316L, C.St. A350 LF2, C.St. A105, B473 N08020 (Alloy 20), B164 N04400 (Monel 400), B574 N06022 (Alloy C22), B574 N10276 (Alloy C276), A479 S31254 (254 SMO), A479 S31803 (Duplex), A479 S32750 (Super Duplex)	1
2	End	A479 316/316L, A350 LF2, C.St. A105, B473 N08020, B164 N04400, B574 N06022, B574 N10276, A479 S31254, A479 S31803, A479 S32750	2
3	Ball	S.St. for 1/2" and 3/4" valves: A564 Gr.630 H1150D 17-4PH, S.St. for 1" and up valves: A351 CF8M, A479 316/316L, B473 N08020, B164 N04400, B574 N06022, B574 N10276, A479 S31254, A479 S31803, A479 S32750, B637 UNS-N07718 (Inconel 718)	1
4	Stem	A564 Gr.630 H1150D 17-4PH, B164 N04400, B574 N06022, A479 S31803, A479 S32750, B637 UNS-N07718 (Inconel 718)	1
5*	Seat	PVDF, DELRIN, PEEK, CF PEEK, PCTFE (KEL-F)	2
6*	Body seal	PTFE, Graphite, NBR, Viton	2
6A	Support ring	A479 316/316L, A350 LF2, B473 N08020, B164 N04400, B574 N06022, B574 N10276, A479 S31254, A479 S31803, A479 S32750	1

Item	Description	Material specification	Qty.
7*	Stem thrust seal	PEEK, CF PEEK, PCTFE (KEL-F), TFM ⁽²⁾ , CF PTFE ⁽²⁾	1
7a**	Anti-abrasion ring	PEEK, CF PEEK, PCTFE (KEL-F), TFM ⁽²⁾ , CF PTFE ⁽²⁾	1
8	Stop pin	A582 303	1
9*	Stem seal	CF PTFE, TFM, Graphite ⁽²⁾	1
10	Follower	B783 316L	1
10A*	Slide bearing	TF316	1
12	Stem nut	A194 8M, EN3506-2 A4-80	1
13	Tab lock washer	A240 304	1
14	Handle	C.St. Zinc plate, A240 316L	1
14A	Stop plate	C.St. 1.0402 Zinc plate, A240 430	1
14B	Wrench head	Ductile Iron A536 Gr. 65-45-12, A216 WCB, A351 CF8M	1
16	Wrench bolt	EN3506-1 A2-70/A4-80, A193 Gr B8/B8M	1
17	Sleeve	PVC	1
18	Body bolts	A193 B8M, EN3506-1 A4-80	16-28
20	Anti static spring	A313 302	2
21	Anti static plunger	A479 304	2
23	Tag (not shown)	A167 304	1

⁽¹⁾ 27 Series is Habonim's standard valve design without the HermetiX™ stem seal construction

⁽²⁾ This material can only be used as part of non HermetiX™ design

* Repair kit components

** Only with HermetiX™ stem seal

Floating Ball Valves

High pressure

General

24 Series

27 Series

28 Series

Ordering code system

Size 1/4"- 1 1/4" | DN8-DN32 | Class 2500 | 28X/28W/28⁽¹⁾ Series

Valve dimensions

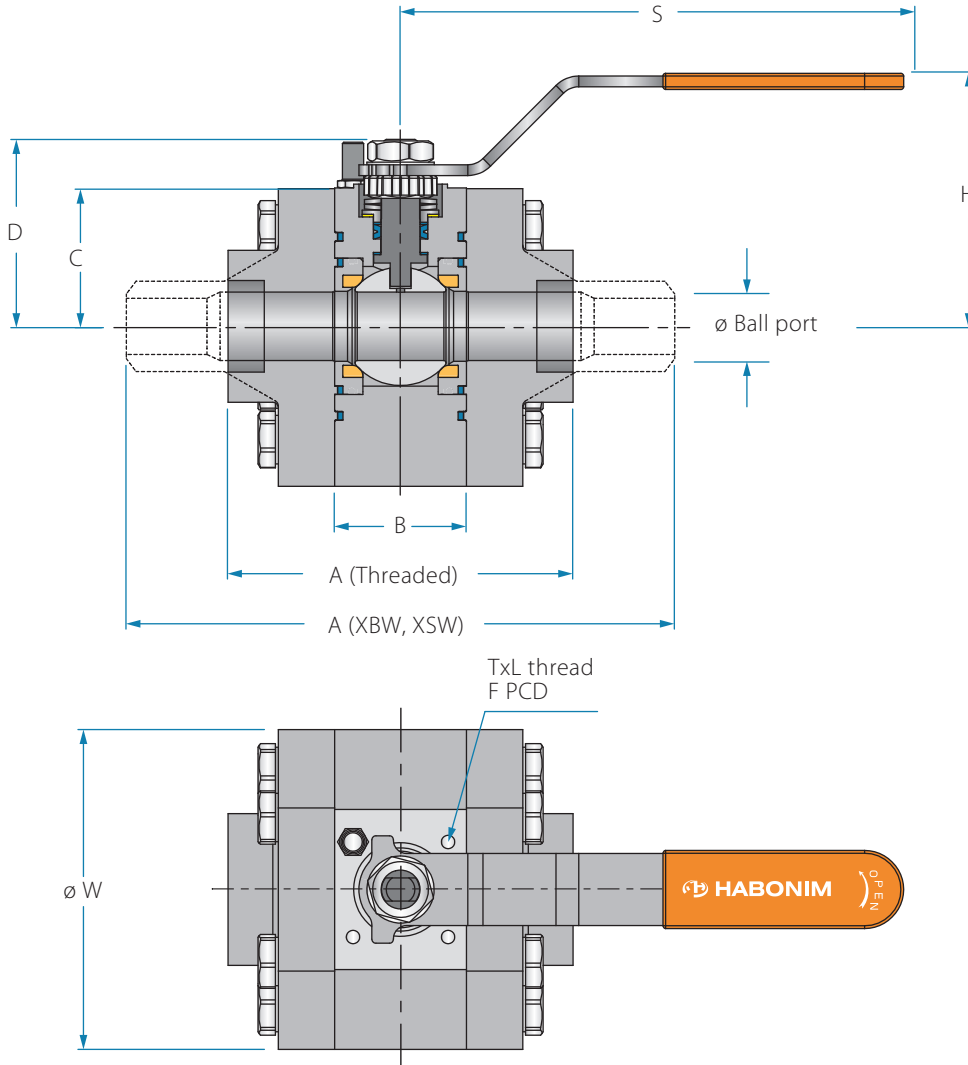

Preparation for actuation

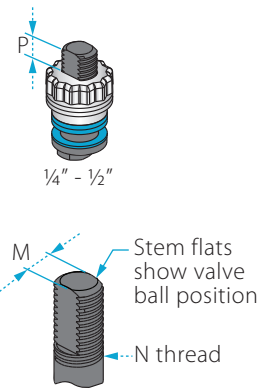

Std. port	Unit	Ball port	A THD	A XBW/XSW	B	C	D	ØW	H	M	N	P	S	ISO PCD	F	TxL	Weight			Kv
																	THD	XBW	Cv	
DN8	mm	11.10	92.00	159.00	35.00	29.00	38.00	69.00	63.00	5.50	3/8" UNF	6.70	150.00	(F03)	36.00	M5x8	2.00	2.75	2.6	
1/4"	inch	0.44	3.62	6.26	1.38	1.14	1.50	2.72	2.48	0.22		0.26	5.91	1.42				4.41	6.06	
DN10	mm	11.10	92.00	159.00	35.00	29.00	38.00	69.00	63.00	5.50	3/8" UNF	6.70	150.00	(F03)	36.00	M5x8	2.00	2.75	4.3	
3/8"	inch	0.44	3.62	6.26	1.38	1.14	1.50	2.72	2.48	0.22		0.26	5.91	1.42				4.41	6.06	
DN15	mm	11.10	92.00	159.00	35.00	29.00	38.00	69.00	63.00	5.50	3/8" UNF	6.70	150.00	(F03)	36.00	M5x8	2.00	2.75	6.9	
1/2"	inch	0.44	3.62	6.26	1.38	1.14	1.50	2.72	2.48	0.22		0.26	5.91	1.42				4.41	6.06	
DN20	mm	13.00	100.00	169.00	40.00	34.10	52.40	89.00	82.20	7.50	7/16" UNF	11.30	172.60	(F04)	42.00	M5x8	3.50	4.30	10	
3/4"	inch	0.51	3.94	6.65	1.57	1.34	2.06	3.50	3.24	0.30		0.44	6.80	1.65				7.72	9.48	
DN25	mm	20.60	125.00	190.00	49.00	43.70	66.00	104.00	92.50	8.70	9/16" UNF	14.30	230.00	(F05)	50.00	M6x8	6.00	6.80	28	
1"	inch	0.81	4.92	7.48	1.93	1.72	2.60	4.09	3.64	0.34		0.56	9.06	1.97				13.23	14.99	
DN32	mm	25.40	133.00	193.00	49.00	51.50	69.50	119.00	96.00	8.70	9/16" UNF	14.30	237.00	(F05)	50.00	M6x8	8.50	9.50	49	
1 1/4"	inch	1.00	5.24	7.60	1.93	2.03	2.74	4.69	3.78	0.34		0.56	9.33	1.97				18.74	20.95	

Components & materials

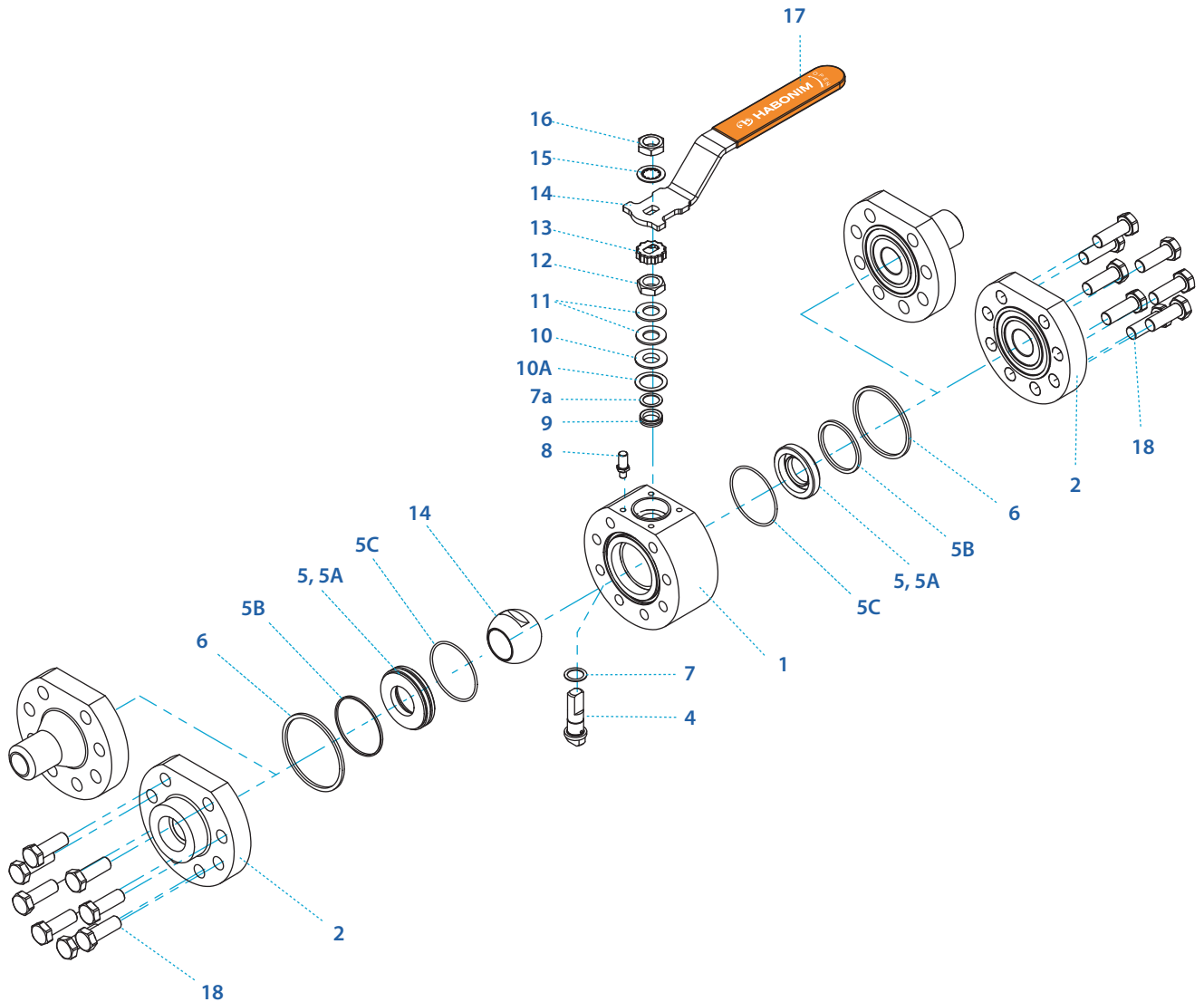

Item	Description	Material specification	Qty.
1	Body	S.St. A479 316/316L, C.St. A350 LF2, C.St. A105, C.St. A105, B473 N08020 (Alloy 20), B164 N04400 (Monel 400), B574 N06022 (Alloy C22), B574 N10276 (Alloy C276), A479 S31254 (254 SMO), A479 S31803 (Duplex), A479 S32750 (Super Duplex)	1
2	End	A479 316/316L, A350 LF2, C.St. A105, B473 N08020, B164 N04400, B574 N06022, B574 N10276, A479 S31254, A479 S31803, A479 S32750	2
3	Ball	A564 Gr.630 H1150D 17-4PH, S.St. A351 CF8M, A479 316/316L, B473 N08020, B164 N04400, B574 N06022, B574 N10276, A479 S31254, A479 S31803, A479 S32750, B637 UNS-N07718 (Inconel 718)	1
4	Stem	A564 Gr.630 H1150D 17-4PH, B164 N04400, B574 N06022, A479 S31803, A479 S32750, B637 UNS-N07718 (Inconel 718)	1
5*	Seat insert	PVDF, DELRIN, PEEK, CF PEEK, PCTFE (KEL-F)	2
5A*	Seat housing	A479 316/316L, A350 LF2, B473 N08020, B164 N04400, B574 N06022, B574 N10276, A479 S31254, A479 S31803, A479 S32750	2
5B*	Seat seal	PTFE, Graphite, NBR, Viton	2
5C*	Seat seal (optional)	NBR, Viton	2

Item	Description	Material specification	Qty.
6*	Body seal	PTFE, Graphite, NBR, Viton	2
7*	Stem thrust seal	PEEK, CF PEEK, PCTFE (KEL-F), TFM ⁽²⁾ , CF PTFE ⁽²⁾	1
7a**	Anti-abrasion ring	PEEK, CF PEEK, PCTFE (KEL-F), TFM ⁽²⁾ , CF PTFE ⁽²⁾	1
8	Stop pin	A582 303	1
9*	Stem seal	CF PTFE, TFM, Graphite ⁽²⁾	1
10	Follower	B783 316L	1
10A*	Slide bearing	TF316	1
11	Disc spring	A693 631 17-7PH	2
12	Stem nut	A194 8M, EN3506-2 A4-80	1
13	Locking clip	A167 304	1
14	Handle	C.St. A29 G10200 Zinc plate, S.St. A240 430	1
15	Serrated washer	A240 410	1
16	Handle nut	A194 8M, EN3506-2 A4-80	1
17	Sleeve	PVC	1
18	Body bolts	A193 B8M, EN3506-1 A4-80	12-16
20	Anti static spring	A313 302	1
21	Anti static plunger	A479 304	1
23	Tag (not shown)	A167 304	1

⁽¹⁾ 28 Series is Habonim's standard valve design without the HermetiX™ stem seal construction

⁽²⁾ This material can only be used as part of non HermetiX™ design

* Repair kit components

** Only with HermetiX™ stem seal. Does not supplied in 1/2" and 3/4" valves

Floating Ball Valves

High pressure

General

24 Series

27 Series

28 Series

Ordering code system

Size 1½" - 8" | DN40-DN200 | Class 2500 | 28X/28W/28⁽¹⁾ Series

Valve dimensions

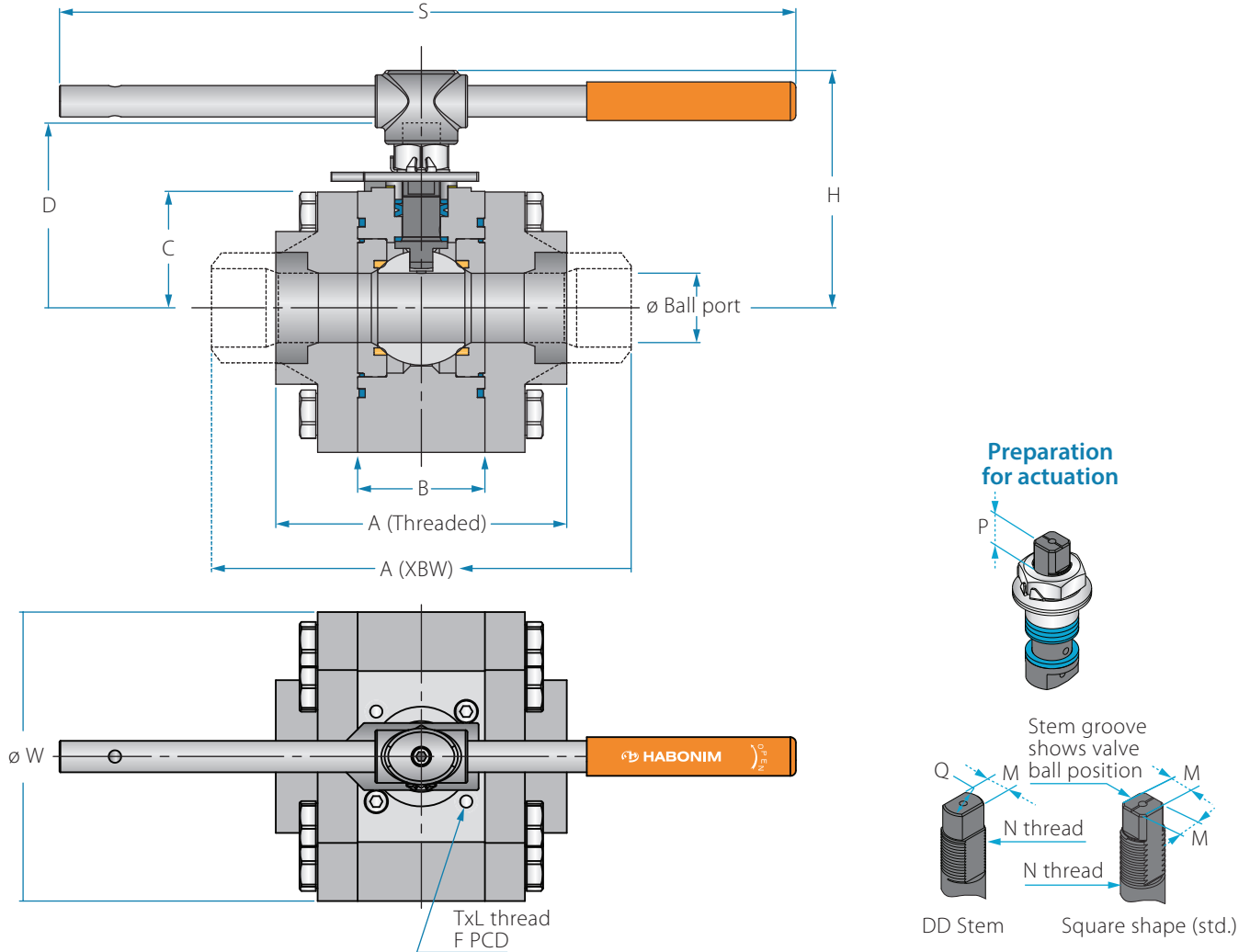

Std. port	Unit	Ball port	A THD	A XBW/XSW	B	C	D	ØW	H	M	N	P	Q	S	ISO PCD	F	TxL	Weight		Kv
																		THD	XBW	
DN40	mm	31.80	154.00	241.00	70.00	53.00	94.60	134.00	123.30	13.90	M20x2.5	14.25	Full thread	400.00	(F07)	70.00	M8x10	12.50	14.50	69
1½"	inch	1.25	6.06	9.49	2.76	2.09	3.72	5.28	4.85	0.55	M20x2.5	0.56	thread	15.75		2.76	M8x10	27.56	31.97	80
DN50	mm	38.20	157.00	241.00	70.00	64.10	101.60	169.00	147.00	13.90	M20x2.5	13.80	Full thread	400.00	(F07)	70.00	M8x10	18.70	22.00	102
2"	inch	1.50	6.18	9.49	2.76	2.52	4.00	6.65	5.79	0.55	M20x2.5	0.54	thread	15.75		2.76	M8x10	41.23	48.51	118
DN65	mm	50.90	194.00	302.00	94.00	87.50	134.00	197.00	174.50	18.90	1-¼"	20.00	22.70	610.00	(F10)	102.00	M10x13	34.00	36.00	208
2½"	inch	2.00	7.64	11.89	3.70	3.44	5.28	7.76	6.87	0.74	UNS-2A	0.79	0.89	24.02		4.02	M10x13	74.97	79.38	241
DN80	mm	63.75	254.00	378.00	115.00	110.00	167.60	249.00	229.50	28.50	1-½"	22.25	35.20	916.00	(F12)	125.00	M12x18	66.00	76.00	300
3"	inch	2.51	10.00	14.88	4.53	4.33	6.60	9.80	9.04	1.12	UNF-2A	0.88	1.39	36.06		4.92	M12x18	145.53	167.58	348
DN100	mm	82.80	N/A	410.00	130.00	136.00	203.00	298.00	263.00	28.50	1-½"	30.00	35.20	916.00	(F14)	140.00	M16x20	-	110.00	615
4"	inch	3.26	N/A	16.14	5.12	5.35	7.99	11.73	10.35	1.12	UNF-2A	1.18	1.39	36.06		5.51	M16x20	-	242.55	713
DN150	mm	111.10	N/A	510.00	175.00	177.00	281.00	389.00	-	35.90	2"	40.00	43.50	-	(F16)	165.00	M20x25	-	235.00	872
6"	inch	4.37	N/A	20.08	6.89	6.97	11.06	15.31	-	1.41	UN-2A	1.57	1.71	-		6.50	M20x25	-	518.18	1012
DN200	mm	144.40	N/A	650.00	210.00	227.00	367.00	489.00	-	45.90	2-¾"	50.60	-	-	-	165.00	M24x25	-	490.00	1552
8"	inch	5.69	N/A	25.59	8.27	8.94	14.45	19.25	-	1.81	UN-2A	1.99	-	-		6.50	M24x25	-	1080.45	1800

Components & materials

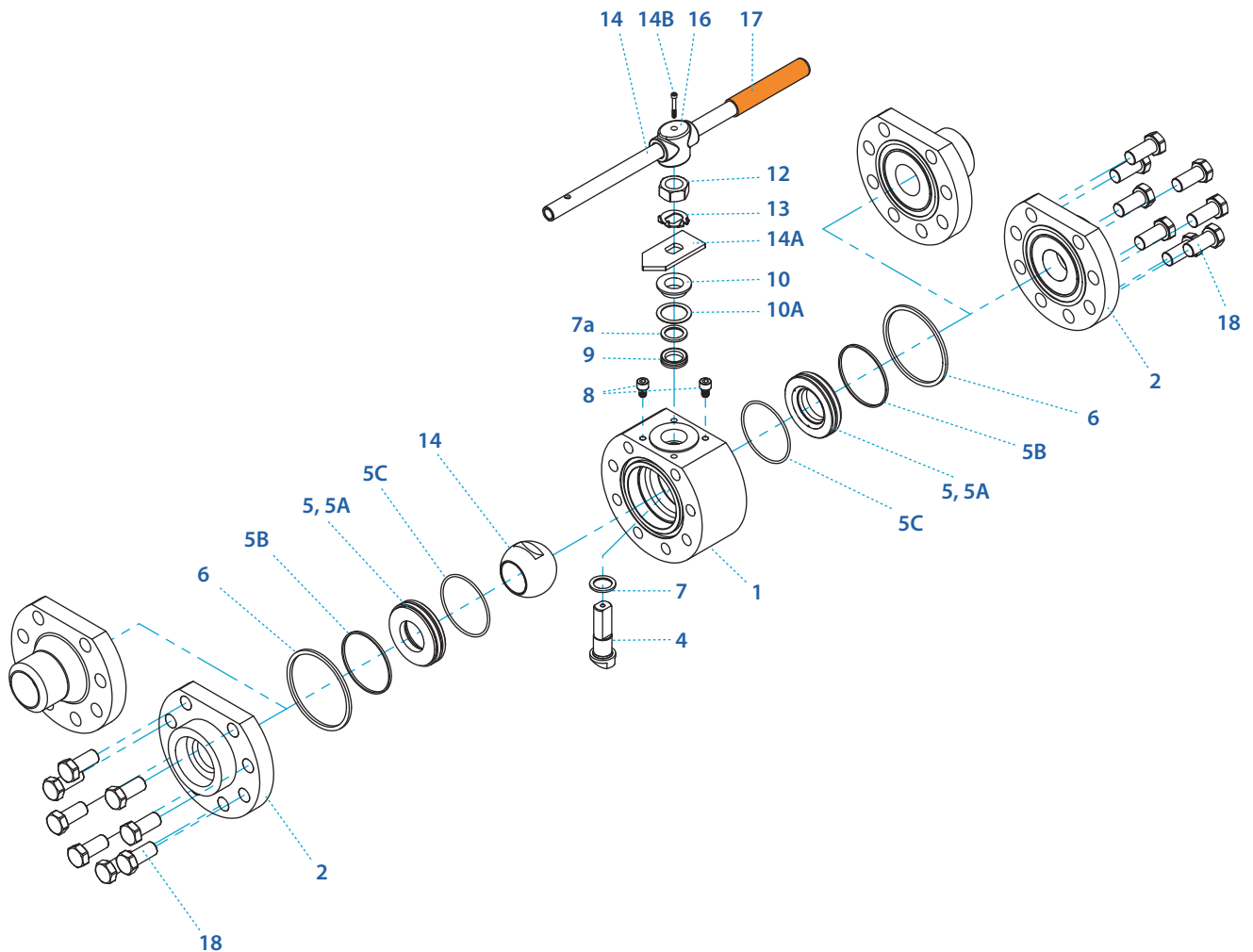

Item	Description	Material specification	Qty.
1	Body	S.St. A479 316/316L, C.St. A350 LF2, C.St. A105, C.St. A105, B473 N08020 (Alloy 20), B164 N04400 (Monel 400), B574 N06022 (Alloy C22), B574 N10276 (Alloy C276), A479 S31254 (254 SMO), A479 S31803 (Duplex), A479 S32750 (Super Duplex)	1
2	End	A479 316/316L, A350 LF2, C.St. A105, B473 N08020, B164 N04400, B574 N06022, B574 N10276, A479 S31254, A479 S31803, A479 S32750	2
3	Ball	S.St. for 1/2" and 3/4" valves: A564 Gr.630 H1150D 17-4PH, S.St. for 1" and up valves: A351 CF8M, A479 316/316L, B473 N08020, B164 N04400, B574 N06022, B574 N10276, A479 S31254, A479 S31803, A479 S32750, B637 UNS-N07718 (Inconel 718)	1
4	Stem	A564 Gr.630 H1150D 17-4PH, B164 N04400, B574 N06022, A479 S31803, A479 S32750, B637 UNS-N07718 (Inconel 718)	1
5*	Seat insert	PVDF, DELRIN, PEEK, CF PEEK, PCTFE (KEL-F)	2
5A*	Seat housing	A479 316/316L, A350 LF2, B473 N08020, B164 N04400, B574 N06022, B574 N10276, A479 S31254, A479 S31803, A479 S32750	2
5B*	Seat seal	PTFE, Graphite, NBR, Viton	2
5C*	Seat seal (optional)	NBR, Viton	2

Item	Description	Material specification	Qty.
6*	Body seal	PTFE, Graphite, NBR, Viton	2
7*	Stem thrust seal	PEEK, CF PEEK, PCTFE (KEL-F), TFM ⁽²⁾ , CF PTFE ⁽²⁾	1
7a**	Anti-abrasion ring	PEEK, CF PEEK, PCTFE (KEL-F), TFM ⁽²⁾ , CF PTFE ⁽²⁾	1
8	Stop pin	A582 303	1
9*	Stem seal	CF PTFE, TFM, Graphite ⁽²⁾	1
10	Follower	B783 316L	1
10A*	Slide bearing	TF316	1
11	Disc spring	A693 631 17-7PH	2
12	Stem nut	A194 8M, EN3506-2 A4-80	1
13	Locking clip	A167 304	1
14	Handle	C.St. A29 G10200 Zinc plate, S.St. A240 430	1
15	Serrated washer	A240 410	1
16	Handle nut	A194 8M, EN3506-2 A4-80	1
17	Sleeve	PVC	1
18	Body bolts	A193 B8M, EN3506-1 A4-80	12-16
20	Anti static spring	A313 302	1
21	Anti static plunger	A479 304	1
23	Tag (not shown)	A167 304	1

⁽¹⁾ 28 Series is Habonim's standard valve design without the HermetiX™ stem seal construction

⁽²⁾ This material can only be used as part of non HermetiX™ design

* Repair kit components

** Only with HermetiX™ stem seal

Floating Ball Valves

High pressure

General

24 Series

27 Series

28 Series

Ordering code system

Size 1/2" - 1 1/4" | DN15-DN32 | Class 2500 | 28W/28⁽¹⁾ Series: Flanged ANSI Raised Face (RF), Ring Type Joint (RTJ)

Valve dimensions

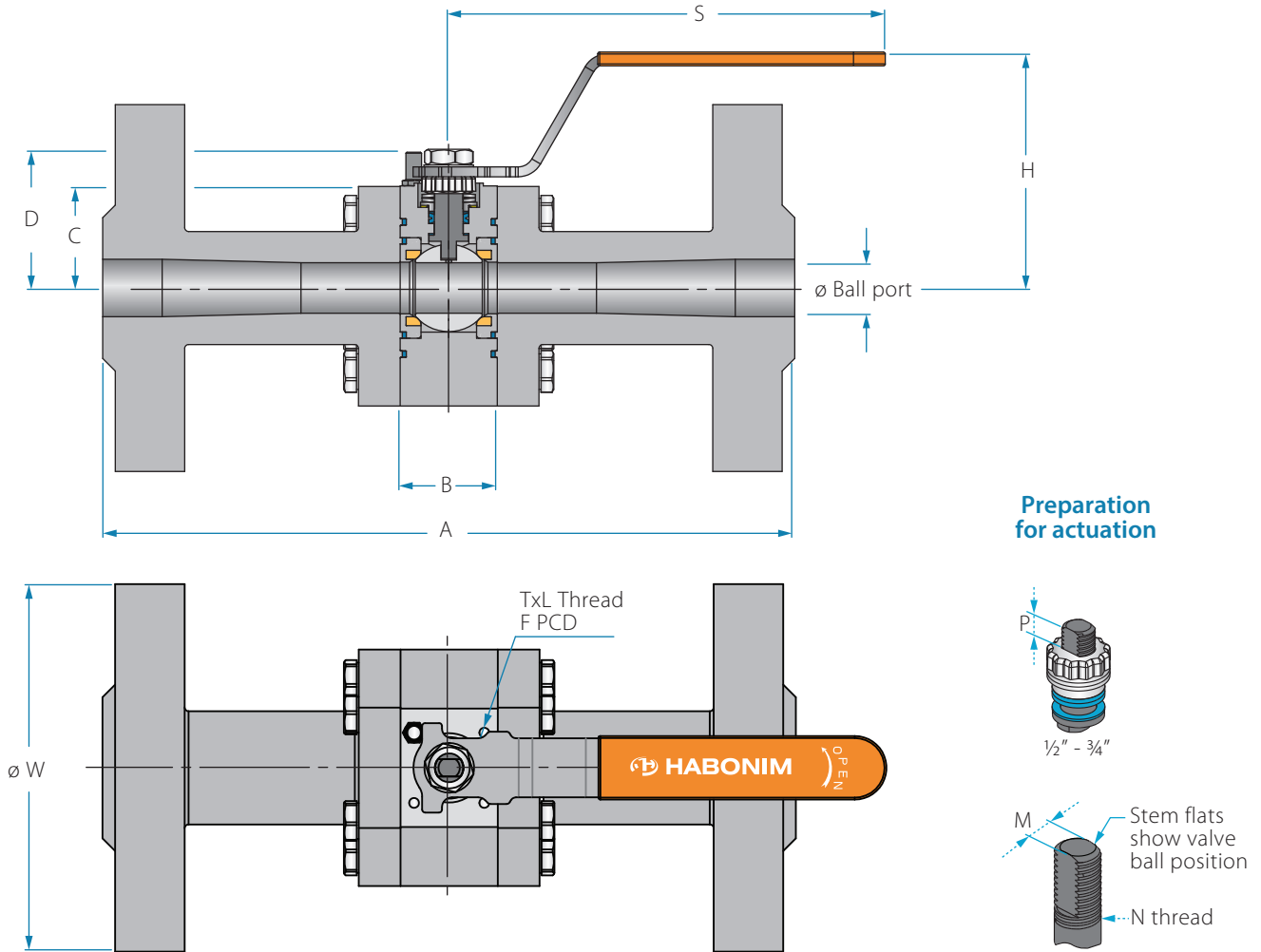

Preparation for actuation

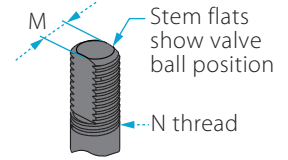
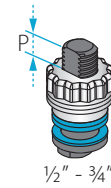

Std. port	Unit	Ball port	#1500 RF		#2500 RF		#1500 RTJ		#2500 RTJ		B	C	D	H	M	N	P	S	ISO PCD	F	TxL	Weight		Kv
			A	W	A	W	A	W	A	W												#1500	#2500	
DN15	mm	11.10	216.00	120.00	264.00	135.00	216.00	120.00	264.00	135.00	35.00	29.00	38.00	95.00	5.50	3/8" UNF	6.70	150.00	(F03)	36.00	M5x8	6.30	8.50	6.9
1/2"	inch	0.44	8.50	4.72	10.39	5.31	8.50	4.72	10.39	5.31	1.38	1.14	1.50	3.74	0.22	3/8" UNF	0.26	5.91		1.42	M5x8	13.89	18.74	8.0
DN20	mm	13.00	229.00	130.00	273.00	140.00	229.00	130.00	273.00	140.00	40.00	34.10	52.40	101.00	7.50	7/16" UNF	11.30	169.00	(F04)	42.00	M5x8	11.00	13.50	10
3/4"	inch	0.51	9.02	5.12	10.75	5.51	9.02	5.12	10.75	5.51	1.57	1.34	2.06	3.98	0.30	7/16" UNF	0.44	6.65		1.65	M5x8	24.26	29.77	12
DN25	mm	20.60	254.00	150.00	307.00	160.00	254.00	150.00	307.00	160.00	49.00	43.70	66.00	113.00	8.70	9/16" UNF	14.30	219.00	(F05)	50.00	M6x8	15.00	19.00	28
1"	inch	0.81	10.00	5.91	12.09	6.30	10.00	5.91	12.09	6.30	1.93	1.72	2.60	4.45	0.34	9/16" UNF	0.56	8.62		1.97	M6x8	33.08	41.90	32
DN32	mm	25.40	280.00	160.00	349.00	185.00	280.00	160.00	352.00	185.00	49.00	51.50	69.50	401.00	8.70	9/16" UNF	14.30	237.00	(F05)	50.00	M6x8	20.00	26.00	49
1 1/4"	inch	1.00	11.02	6.30	13.74	7.28	11.02	6.30	13.86	7.28	1.93	2.03	2.74	15.79	0.34	9/16" UNF	0.56	9.33		1.97	M6x8	44.10	57.33	57

Size 1/2" - 1 1/4" | DN15-DN32 | Class 2500 | 28W/28⁽¹⁾ Series: Flanged ANSI Raised Face (RF), Ring Type Joint (RTJ)

Components & materials

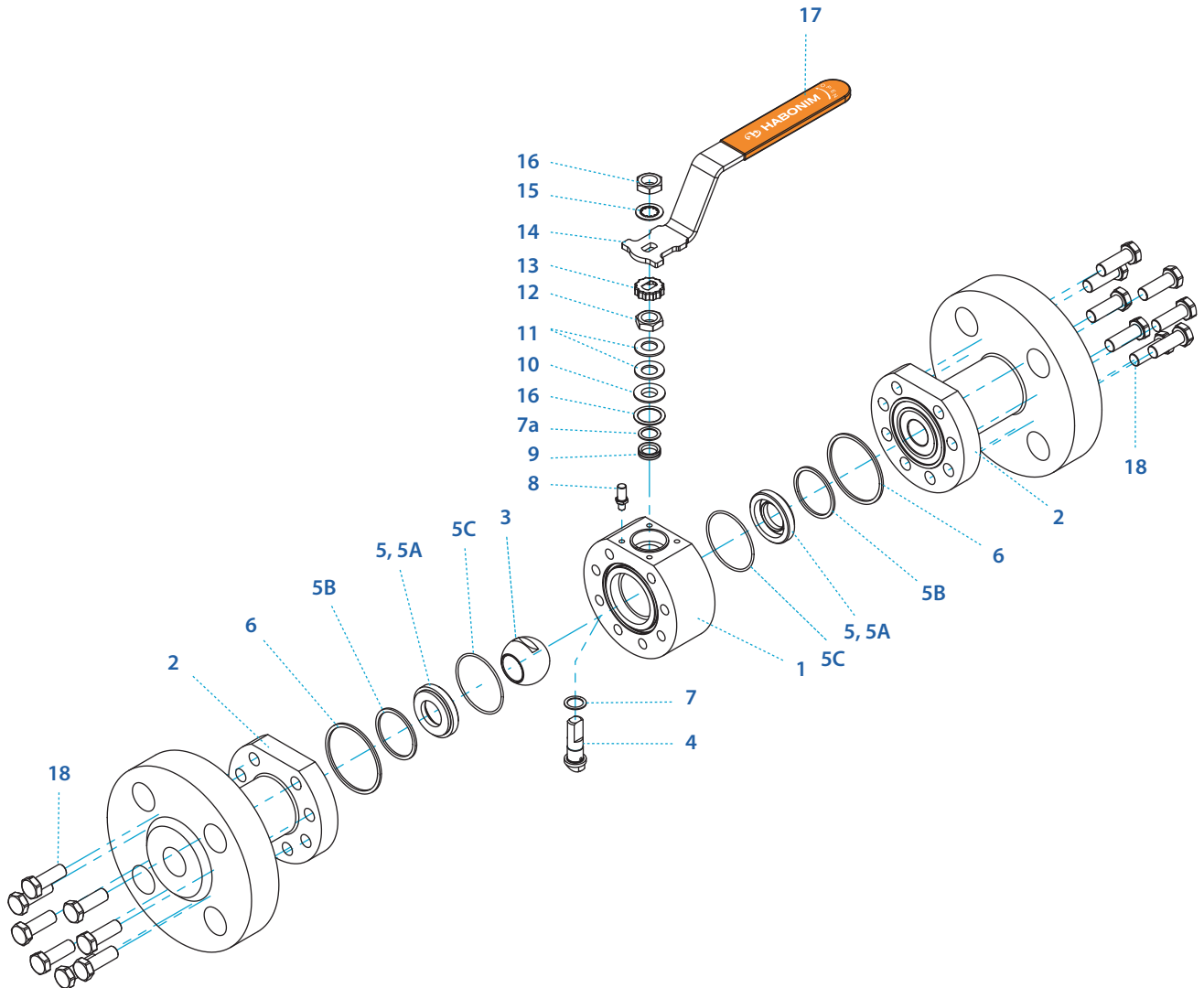

Item	Description	Material specification	Qty.
1	Body	S.St. A479 316/316L, C.St. A350 LF2, C.St. A105, C.St. A105, B473 N08020 (Alloy 20), B164 N04400 (Monel 400), B574 N06022 (Alloy C22), B574 N10276 (Alloy C276), A479 S31254 (254 SMO), A479 S31803 (Duplex), A479 S32750 (Super Duplex)	1
2	End	A479 316/316L, A350 LF2, C.St. A105, B473 N08020, B164 N04400, B574 N06022, B574 N10276, A479 S31254, A479 S31803, A479 S32750	2
3	Ball	S.St. for 1/2" and 3/4" valves: A564 Gr.630 H1150D 17-4PH, S.St. for 1" and up valves: A351 CF8M, A479 316/316L, B473 N08020, B164 N04400, B574 N06022, B574 N10276, A479 S31254, A479 S31803, A479 S32750, B637 UNS-N07718 (Inconel 718)	1
4	Stem	A564 Gr.630 H1150D 17-4PH, B164 N04400, B574 N06022, A479 S31803, A479 S32750, B637 UNS-N07718 (Inconel 718)	1
5*	Seat insert	PVDF, DELRIN, PEEK, CF PEEK, PCTFE (KEL-F)	2
5A*	Seat housing	A479 316/316L, A350 LF2, B473 N08020, B164 N04400, B574 N06022, B574 N10276, A479 S31254, A479 S31803, A479 S32750	2
5B*	Seat seal	PTFE, Graphite, NBR, Viton	2
5C*	Seat seal (optional)	NBR, Viton	2

Item	Description	Material specification	Qty.
6*	Body seal	PTFE, Graphite, NBR, Viton	2
7*	Stem thrust seal	PEEK, CF PEEK, PCTFE (KEL-F), TFM ⁽²⁾ , CF PTFE ⁽²⁾	1
7a**	Anti-abrasion ring	PEEK, CF PEEK, PCTFE (KEL-F), TFM ⁽²⁾ , CF PTFE ⁽²⁾	1
8	Stop pin	A582 303	1
9*	Stem seal	CF PTFE, TFM, Graphite ⁽²⁾	1
10	Follower	B783 316L	1
10A*	Slide bearing	TF316	1
11	Disc spring	A693 631 17-7PH	2
12	Stem nut	A194 8M, EN3506-2 A4-80	1
13	Locking clip	A167 304	1
14	Handle	C.St. A29 G10200 Zinc plate, S.St. A240 430	1
15	Serrated washer	A240 410	1
16	Handle nut	A194 8M, EN3506-2 A4-80	1
17	Sleeve	PVC	1
18	Body bolts	A193 B8M, EN3506-1 A4-80	12-16
20	Anti static spring	A313 302	1
21	Anti static plunger	A479 304	1
23	Tag (not shown)	A167 304	1

⁽¹⁾ 28 Series is Habonim's standard valve design without the HermetiX™ stem seal construction

⁽²⁾ This material can only be used as part of non HermetiX™ design

* Repair kit components

** Only with HermetiX™ stem seal. Does not supplied in 1/2" and 3/4" valves

Floating Ball Valves

High pressure

General

24 Series

27 Series

28 Series

Ordering code system

Size 1½" - 8" | DN40-DN200 | Class 2500 | 28W/28⁽¹⁾ Series: Flanged ANSI Raised Face (RF), Ring Type Joint (RTJ)

Valve dimensions

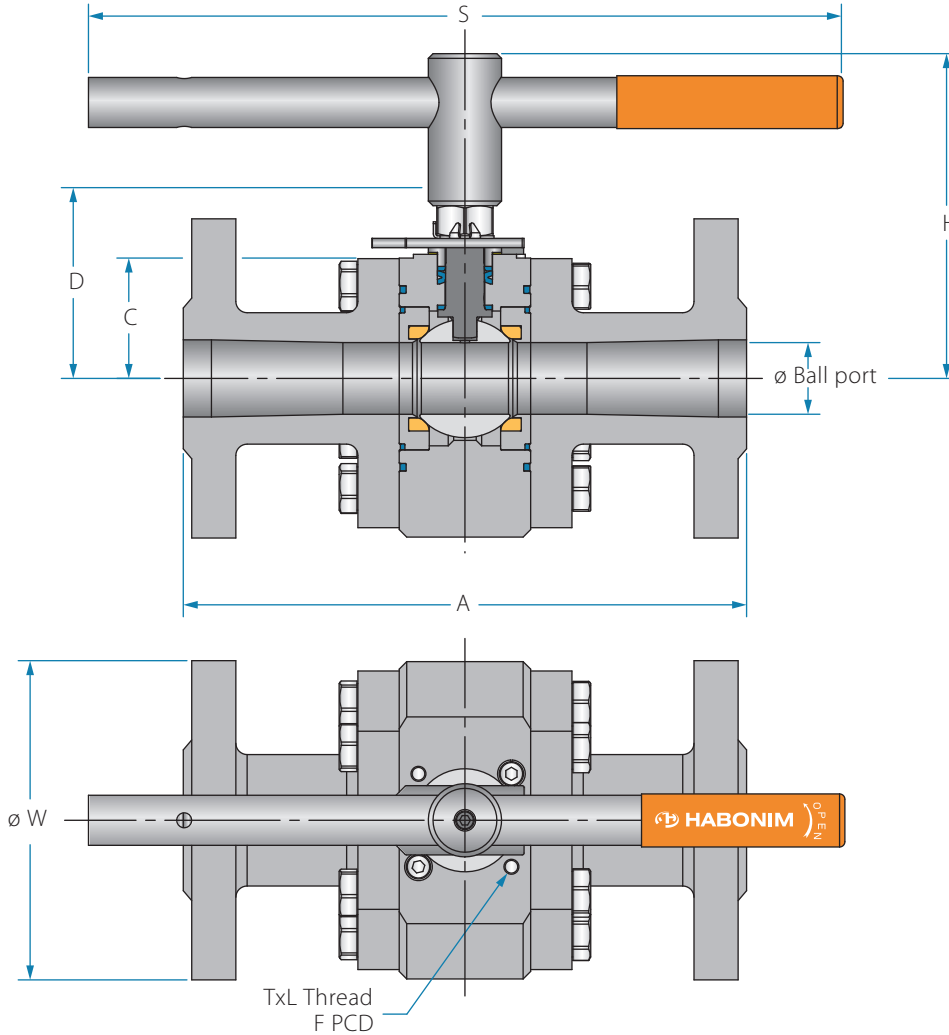

Preparation for actuation

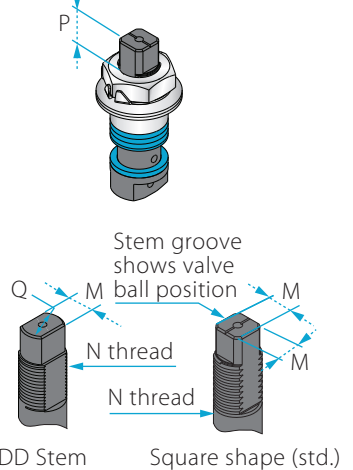

Std. port	Unit	Ball port	#1500 RF		#2500 RF		#1500 RTJ		#2500 RTJ		B	C	D	H	M	N	P	Q	S	ISO PCD	F	TxL	Weight		Kv
			A	W	A	W	A	W	A	W													#1500	#2500	
DN40	mm	31.80	305.00	180.00	384.00	205.00	305.00	180.00	387.00	205.00	70.00	53.00	94.60	152.00	13.90	M20x2.5	14.25	Full thread	400.00 (F07)	70.00	M8x10	27.00	33.00	69	
1½"	inch	1.25	12.01	7.09	15.12	8.07	12.01	7.09	15.24	8.07	2.76	2.09	3.72	5.98	0.55	M20x2.5	0.56	thread	15.75	2.76	M8x10	59.54	72.77	80	
DN50	mm	38.20	368.00	215.00	451.00	235.00	371.00	215.00	454.00	235.00	70.00	64.10	101.60	189.00	13.90	M20x2.5	13.80	Full thread	401.00 (F07)	70.00	M8x10	43.00	54.00	102	
2"	inch	1.50	14.49	8.46	17.76	9.25	14.61	8.46	17.87	9.25	2.76	2.52	4.00	7.44	0.55	M20x2.5	0.54	thread	15.79	2.76	M8x10	94.82	119.07	118	
DN65	mm	50.90	419.00	245.00	508.00	265.00	422.00	245.00	514.00	265.00	94.00	87.50	134.00	158.00	18.90	1-¼"	20.00	22.70	610.00 (F10)	102.00	M10x13	72.00	90.00	208	
2½"	inch	2.00	16.50	9.65	20.00	10.43	16.61	9.65	20.24	10.43	3.70	3.44	5.28	6.22	0.74	UNS-2A	0.79	0.89	24.02	4.02	M10x13	158.76	198.45	241	
DN80	mm	63.75	470.00	265.00	578.00	305.00	473.00	265.00	584.00	305.00	115.00	110.00	167.60	250.00	28.50	1-½"	22.25	35.20	916.00 (F12)	125.00	M12x18	125.00	155.00	300	
3"	inch	2.51	18.50	10.43	22.76	12.01	18.62	10.43	22.99	12.01	4.53	4.33	6.60	9.84	1.12	UNF-2A	0.88	1.39	36.06	4.92	M12x18	275.63	341.78	348	
DN100	mm	82.80	546.00	310.00	673.00	355.00	549.00	310.00	683.00	355.00	130.00	136.00	203.00	306.00	28.50	1-½"	30.00	35.20	916.00 (F14)	140.00	M16x20	180.00	224.00	615	
4"	inch	3.26	21.50	12.20	26.50	13.98	21.61	12.20	26.89	13.98	5.12	5.35	7.99	12.05	1.12	UNF-2A	1.18	1.39	36.06	5.51	M16x20	396.90	493.92	713	
DN150	mm	111.10	705.00	395.00	915.00	485.00	711.00	395.00	927.00	485.00	175.00	177.00	281.00	-	35.90	2"	40.00	43.50	- (F16)	165.00	M20x25	380.00	560.00	872	
6"	inch	4.37	27.76	15.55	36.02	19.09	27.99	15.55	36.50	19.09	6.89	6.97	11.06	-	1.41	UN-2A	1.57	1.71	-	6.50	M20x25	837.90	1234.80	1012	
DN200	mm	144.40	832.00	485.00	1022.00	550.00	842.00	485.00	1038.00	550.00	210.00	227.00	367.00	-	45.90	2"-¾"	50.60	-	-	200.00	M24x25	590.00	660	1552	
8"	Inch	5.69	32.76	19.09	40.24	21.65	33.15	19.09	40.87	21.65	8.27	8.94	14.45	-	1.81	UN-2A	1.99	-	-	-	M24x25	1301.00	1455.30	1800	

Size 1½" - 8" | DN40-DN200 | Class 2500 | 28W/28⁽¹⁾ Series: Flanged ANSI Raised Face (RF), Ring Type Joint (RTJ)

Components & materials

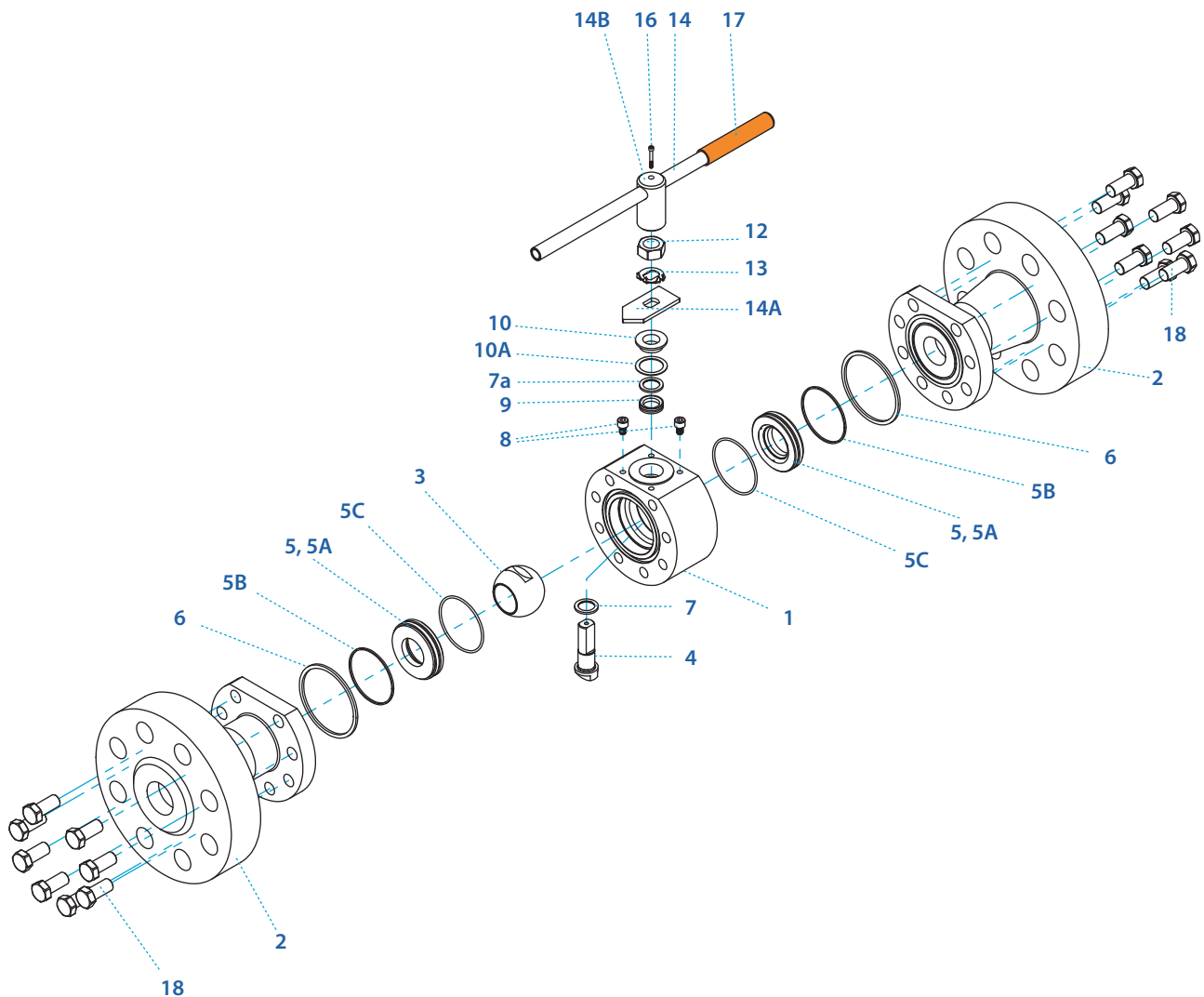

Item	Description	Material specification	Qty.
1	Body	S.St. A479 316/316L, C.St. A350 LF2, C.St A105, C.St A105, B473 N08020 (Alloy 20), B164 N04400 (Monel 400), B574 N06022 (Alloy C22), B574 N10276 (Alloy C276), A479 S31254 (254 SMO), A479 S31803 (Duplex), A479 S32750 (Super Duplex)	1
2	End	A479 316/316L, A350 LF2, C.St A105, B473 N08020, B164 N04400, B574 N06022, B574 N10276, A479 S31254, A479 S31803, A479 S32750	2
3	Ball	S.St for 1/2" and 3/4" valves: A564 Gr.630 H1150D 17-4PH, S.St for 1" and up valves: A351 CF8M, A479 316/316L, B473 N08020, B164 N04400, B574 N06022, B574 N10276, A479 S31254, A479 S31803, A479 S32750, B637 UNS-N07718 (Inconel 718)	1
4	Stem	A564 Gr.630 H1150D 17-4PH, B164 N04400, B574 N06022, A479 S31803, A479 S32750, B637 UNS-N07718 (Inconel 718)	1
5*	Seat insert	PVDF, DELRIN, PEEK, CF PEEK, PCTFE (KEL-F)	2
5A*	Seat housing	A479 316/316L, A350 LF2, B473 N08020, B164 N04400, B574 N06022, B574 N10276, A479 S31254, A479 S31803, A479 S32750	2
5B*	Seat seal	PTFE, Graphite, NBR, Viton	2
5C*	Seat seal (optional)	NBR, Viton	2

Item	Description	Material specification	Qty.
6*	Body seal	PTFE, Graphite, NBR, Viton	2
7*	Stem thrust seal	PEEK, CF PEEK, PCTFE (KEL-F), TFM ⁽²⁾ , CF PTFE ⁽²⁾	1
7a**	Anti-abrasion ring	PEEK, CF PEEK, PCTFE (KEL-F), TFM ⁽²⁾ , CF PTFE ⁽²⁾	1
8	Stop pin	A582 303	1
9*	Stem seal	CF PTFE, TFM, Graphite ⁽²⁾	1
10	Follower	B783 316L	1
10A*	Slide bearing	TF316	1
12	Stem nut	A194 8M, EN3506-2 A4-80	1
13	Tab lock washer	A240 304	1
14	Handle	C.St. Zinc plate, A240 316L	1
14A	Stop plate	C.St. 1.0402 Zinc plate, A240 430	1
14B	Wrench head	Ductile Iron A536 Gr. 65-45-12, A216 WCB, A351 CF8M	1
16	Wrench bolt	EN3506-1 A2-70/A4-80, A193 Gr B8/B8M	1
17	Sleeve	PVC	1
18	Body bolts	A193 B8M, EN3506-1 A4-80	16-30
20	Anti static spring	A313 302	2
21	Anti static plunger	A479 304	2
23	Tag (not shown)	A167 304	1

⁽¹⁾ 28 Series is Habonim's standard valve design without the HermetiX™ stem seal construction

⁽²⁾ This material can only be used as part of non HermetiX™ design

* Repair kit components

** Only with HermetiX™ stem seal

Floating Ball Valves

High pressure

General

24 Series

27 Series

28 Series

Ordering code system

Size 1/2" - 1 1/4" | DN15-DN32 | Class 2500 | 28W/28⁽¹⁾ Series: SAE J518 Flange Code 61 (SAE3000), Code 62 (SAE 6000)

Valve dimensions

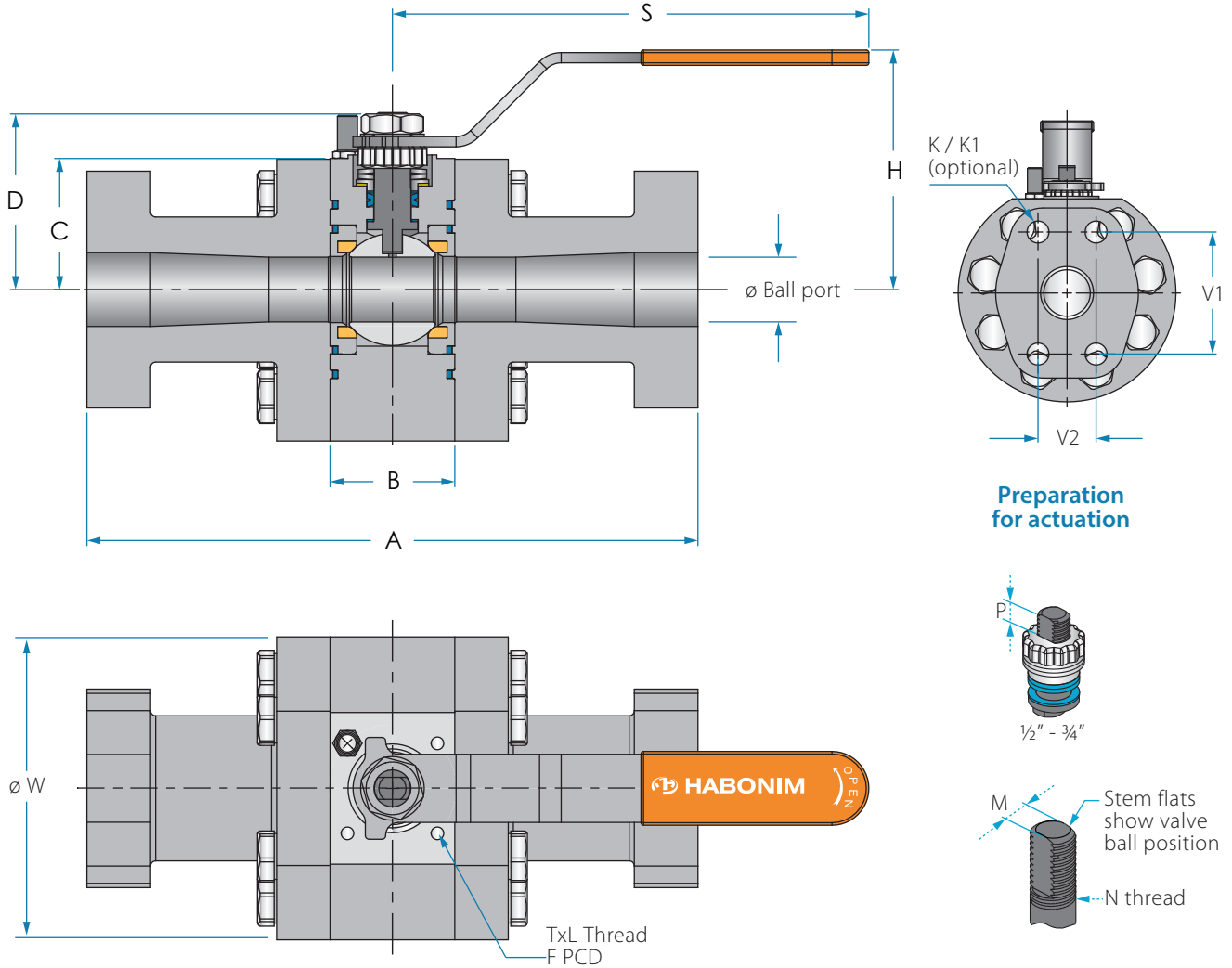

Std. port	Unit	Ball port	SAE3000						SAE6000						B	C	D	W	H	M	N	P	S	ISO PCD	F	TxL	Weight		Kv
			A	K	K1	V1	V2	Pressure bar / psi	A	K	K	V1	V2	Pressure bar / psi													SAE3000	SAE6000	
DN15	mm	11.10	140.00	M8	9.00	38.10	17.50	345.00	165.00	M8	9.00	40.50	18.20	414.00	35.00	29.00	38.00	69.00	63.00	5.50	3/8" UNF	6.70	150.00	(F03)	36.00	M5x8	3.50	4.00	69
1/2"	inch	0.44	5.51			1.50	0.69	5000.00	6.50			1.59	0.72	6000.00	1.38	1.14	1.50	2.72	2.48	0.22		0.26	5.91	1.42	7.72		8.82	8.0	
DN20	mm	13.00	165.00	M10	11.00	47.60	22.20	345.00	180.00	M10	11.00	50.80	23.80	414.00	40.00	34.10	52.40	89.00	82.20	7.50	7/16" UNF	11.30	172.60	(F04)	42.00	M5x8	5.30	6.00	10
3/4"	inch	0.51	6.50			1.87	0.87	5000.00	7.09			2.00	0.94	6000.00	1.57	1.34	2.06	3.50	3.24	0.30		0.44	6.80	1.65	11.69		13.23	12	
DN25	mm	20.60	200.00	M10	11.00	52.40	26.20	345.00	215.00	M12	13.00	57.20	27.80	414.00	49.00	43.70	66.00	104.00	92.00	8.70	9/16" UNF	14.30	230.00	(F05)	50.00	M6x8	8.50	9.50	28
1"	inch	0.81	7.87			2.06	1.03	5000.00	8.46			2.25	1.09	6000.00	1.93	1.72	2.60	4.09	3.62	0.34		0.56	9.06	1.97	18.74		20.95	32	
DN32	mm	25.40	225.00	M10	11.50	58.70	30.20	276.00	240.00	M14	15.00	66.70	31.75	414.00	49.00	51.50	69.50	119.00	96.00	8.70	9/16" UNF	14.30	237.00	(F05)	50.00	M6x8	12.00	13.50	49
1 1/4"	inch	1.00	8.86			2.31	1.19	4000.00	9.45			2.63	1.25	6000.00	1.93	2.03	2.74	4.69	3.78	0.34		0.56	9.33	1.97	26.46		29.77	57	

⁽³⁾ Through hole upon request.

Size 1/2" - 1 1/4" | DN15-DN32 | Class 2500 | 28W/28⁽¹⁾ Series: SAE J518 Flange Code 61 (SAE3000), Code 62 (SAE 6000)

Components & materials

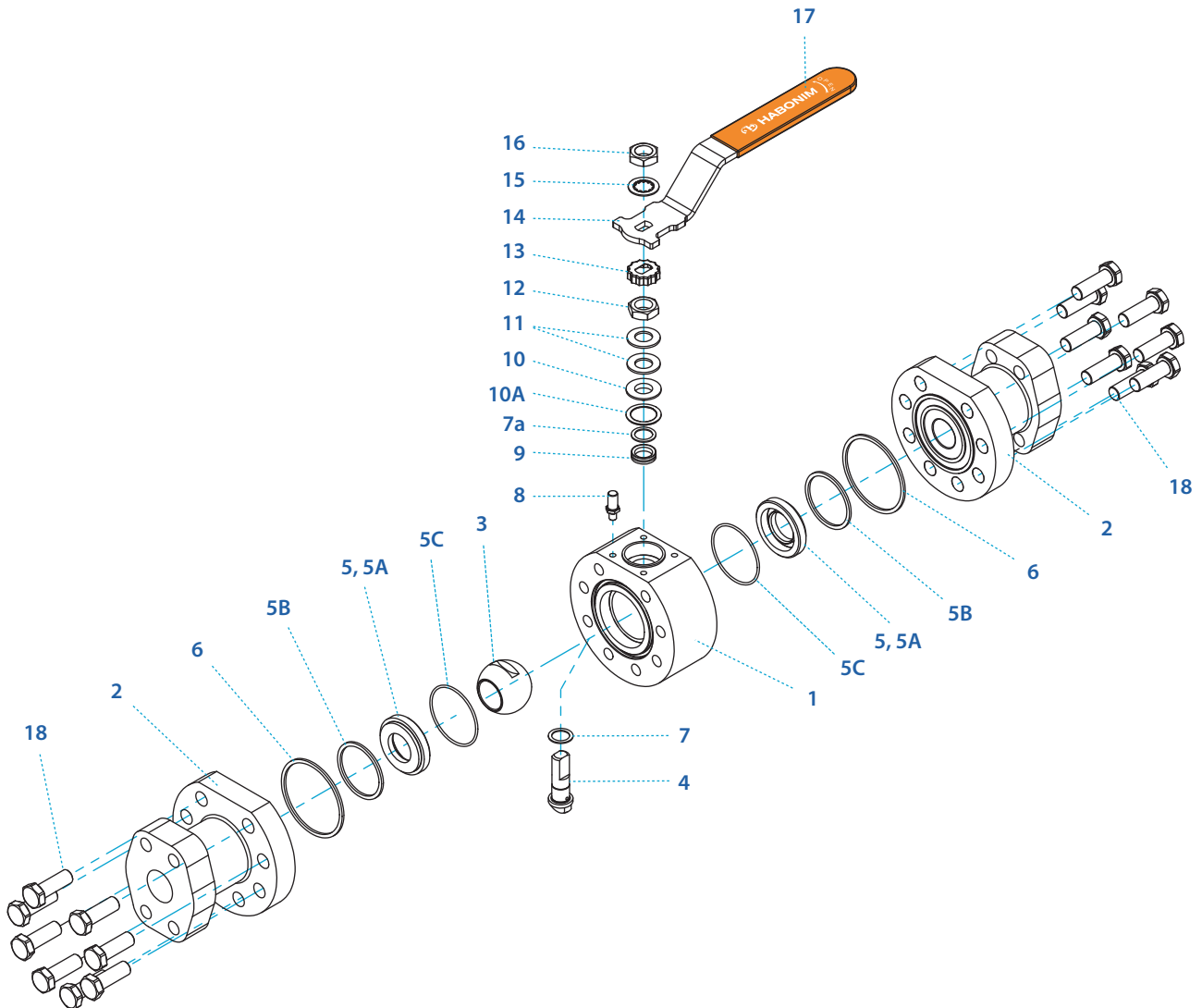

Item	Description	Material specification	Qty.
1	Body	S.St. A479 316/316L, C.St. A350 LF2, C.St. A105, C.St. A105, B473 N08020 (Alloy 20), B164 N04400 (Monel 400), B574 N06022 (Alloy C22), B574 N10276 (Alloy C276), A479 S31254 (254 SMO), A479 S31803 (Duplex), A479 S32750 (Super Duplex)	1
2	End	A479 316/316L, A350 LF2, C.St. A105, B473 N08020, B164 N04400, B574 N06022, B574 N10276, A479 S31254, A479 S31803, A479 S32750	2
3	Ball	S.St. for 1/2" and 3/4" valves: A564 Gr.630 H1150D 17-4PH, S.St. for 1" and up valves: A351 CF8M, A479 316/316L, B473 N08020, B164 N04400, B574 N06022, B574 N10276, A479 S31254, A479 S31803, A479 S32750, B637 UNS-N07718 (Inconel 718)	1
4	Stem	A564 Gr.630 H1150D 17-4PH, B164 N04400, B574 N06022, A479 S31803, A479 S32750, B637 UNS-N07718 (Inconel 718)	1
5*	Seat insert	PVDF, DELRIN, PEEK, CF PEEK, PCTFE (KEL-F)	2
5A*	Seat housing	A479 316/316L, A350 LF2, B473 N08020, B164 N04400, B574 N06022, B574 N10276, A479 S31254, A479 S31803, A479 S32750	2
5B*	Seat seal	PTFE, Graphite, NBR, Viton	2
5C*	Seat seal (optional)	NBR, Viton	2

Item	Description	Material specification	Qty.
6*	Body seal	PTFE, Graphite, NBR, Viton	2
7*	Stem thrust seal	PEEK, CF PEEK, PCTFE (KEL-F), TFM ⁽²⁾ , CF PTFE ⁽²⁾	1
7a**	Anti-abrasion ring	PEEK, CF PEEK, PCTFE (KEL-F), TFM ⁽²⁾ , CF PTFE ⁽²⁾	1
8	Stop pin	A582 303	1
9*	Stem seal	CF PTFE, TFM, Graphite ⁽²⁾	1
10	Follower	B783 316L	1
10A*	Slide bearing	TF316	1
11	Disc spring	A693 631 17-7PH	2
12	Stem nut	A194 8M, EN3506-2 A4-80	1
13	Locking clip	A167 304	1
14	Handle	C.St. A29 G10200 Zinc plate, S.St. A240 430	1
15	Serrated washer	A240 410	1
16	Handle nut	A194 8M, EN3506-2 A4-80	1
17	Sleeve	PVC	1
18	Body bolts	A193 B8M, EN3506-1 A4-80	12-16
20	Anti static spring	A313 302	1
21	Anti static plunger	A479 304	1
23	Tag (not shown)	A167 304	1

⁽¹⁾ 28 Series is Habonim's standard valve design without the HermetiX™ stem seal construction

⁽²⁾ This material can only be used as part of non HermetiX™ design

* Repair kit components

** Only with HermetiX™ stem seal. Does not supplied in 1/2" and 3/4" valves

Floating Ball Valves

High pressure

General

24 Series

27 Series

28 Series

Ordering code system

Size 1½" - 3" | DN40-DN80 | Class 2500 | 28W/28⁽¹⁾ Series: SAE J518 Flange Code 61 (SAE3000), Code 62 (SAE 6000)

Valve dimensions

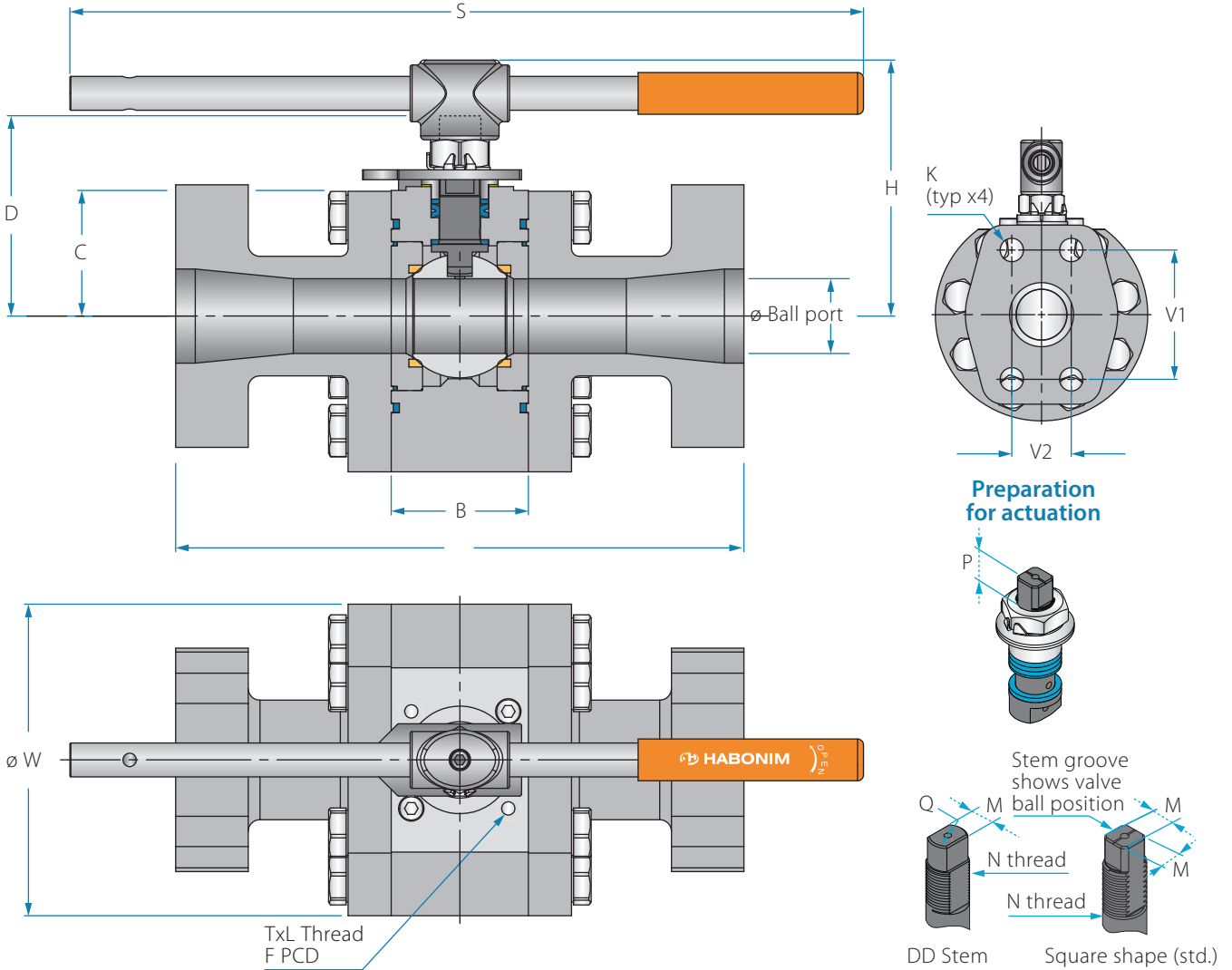

Std. port	Unit	Ball port	SAE3000					SAE6000					B	C	D	W	H	M	N	P	Q	S	ISO PCD	F	TxL	Weight		Kv
			A	K	K1	V1	V2	Pressure bar / psi	A	K	K1	V1														V2	Pressure bar / psi	
DN40	mm	31.80	260.00	M12	13.00	69.85	35.70	207.00	265.00	M16	17.00	79.40	36.50	414.00	70.00	53.00	94.60	134.00	123.30	13.90	14.25	Full thread	400.00 (F07)	70.00	M8x10	16.00	18.00	69
1½"	inch	1.25	10.24			2.75	1.41	3000.00	10.43			3.13	1.44	6000.00	2.76	2.09	3.72	5.28	4.85	0.55	0.56		15.75	2.76		35.28	39.69	80
DN50	mm	38.20	270.00	M12	13.00	77.80	42.90	207.00	315.00	M20	21.00	96.80	44.50	414.00	70.00	64.10	101.60	169.00	189.00	13.90	13.80	Full thread	401.00 (F07)	70.00	M8x10	23.50	26.00	102
2"	inch	1.50	10.63			3.06	1.69	3000.00	12.40			3.81	1.75	6000.00	2.76	2.52	4.00	6.65	7.44	0.55	0.54		15.79	2.76		51.82	57.33	118
DN65	mm	50.90	325.00	M12	13.00	88.90	50.80	172.00	375.00	M24	25.00	123.80	58.70	414.00	94.00	87.50	134.00	197.00	174.50	18.90	20.00	1-¼" UNS-2A	610.00 (F010)	102.00	M10x13	40.00	44.00	208
2½"	inch	2.00	12.80			3.50	2.00	2500.00	14.76			4.87	2.31	6000.00	3.70	3.44	5.28	7.76	6.87	0.74	0.79		0.89	24.02		4.02	88.20	97.02
DN80	mm	63.75	380.00	M16	17.00	106.40	61.30	138.00	450.00	M30	32.00	152.40	71.40	414.00	115.00	110.00	167.60	249.00	229.50	28.50	22.25	1-½" UNS-2A	916.00 (F012)	125.00	M12x18	80.00	90.00	300
3"	inch	2.51	14.96			4.19	2.41	2000.00	17.72			6.00	2.81	6000.00	4.53	4.33	6.60	9.80	9.04	1.12	0.88		1.39	36.06		4.92	198.45	348

Size 1½" - 3" | DN40-DN80 | Class 2500 | 28W/28⁽¹⁾ Series: SAE J518 Flange Code 61 (SAE3000), Code 62 (SAE 6000)

Components & materials

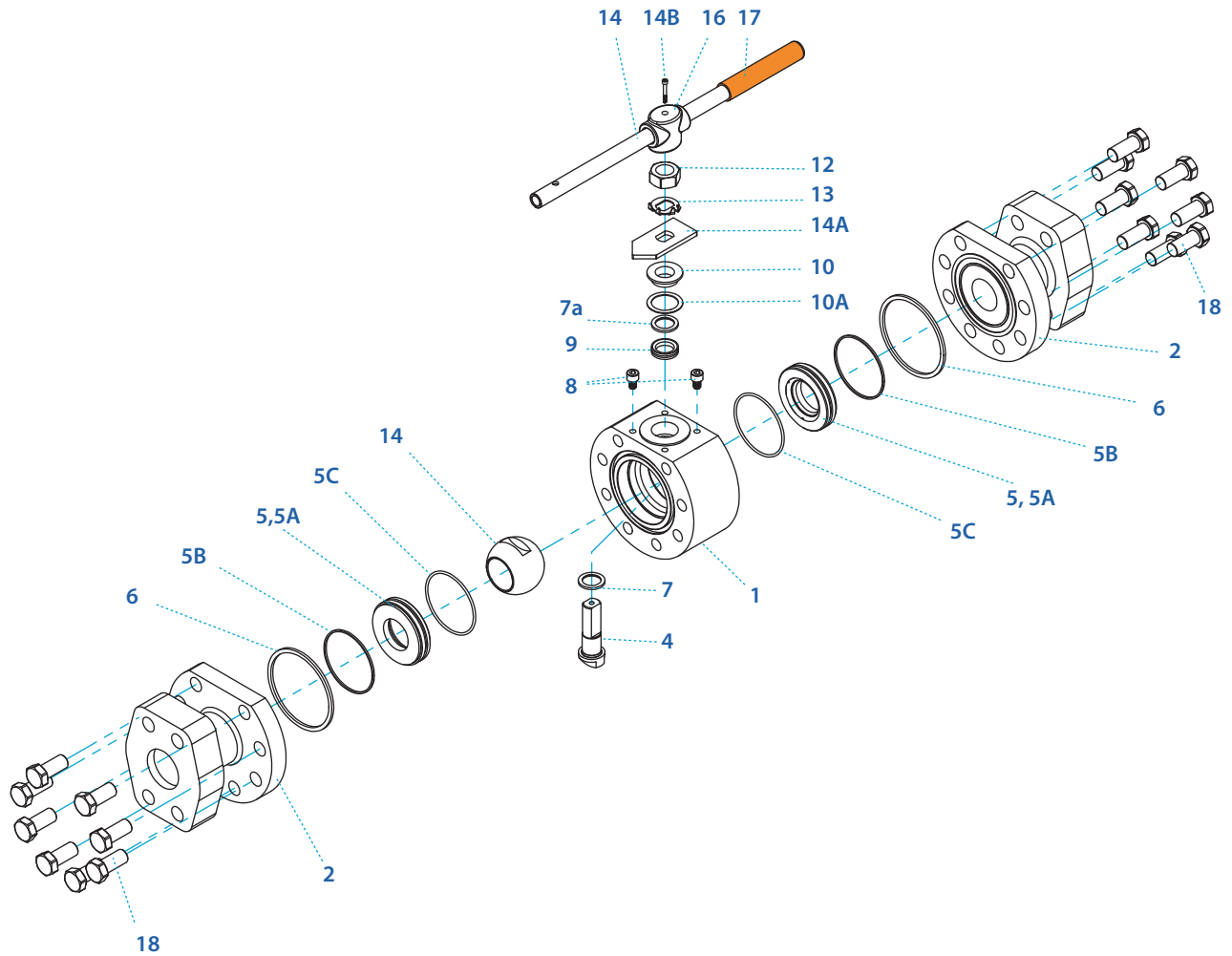

Item	Description	Material specification	Qty.
1	Body	S.St. A479 316/316L, C.St. A350 LF2, C.St. A105, C.St. A105, B473 N08020 (Alloy 20), B164 N04400 (Monel 400), B574 N06022 (Alloy C22), B574 N10276 (Alloy C276), A479 S31254 (254 SMO), A479 S31803 (Duplex), A479 S32750 (Super Duplex)	1
2	End	A479 316/316L, A350 LF2, C.St. A105, B473 N08020, B164 N04400, B574 N06022, B574 N10276, A479 S31254, A479 S31803, A479 S32750	2
3	Ball	S.St. for 1/2" and 3/4" valves: A564 Gr.630 H1150D 17-4PH, S.St. for 1" and up valves: A351 CF8M, A479 316/316L, B473 N08020, B164 N04400, B574 N06022, B574 N10276, A479 S31254, A479 S31803, A479 S32750, B637 UNS-N07718 (Inconel 718)	1
4	Stem	A564 Gr.630 H1150D 17-4PH, B164 N04400, B574 N06022, A479 S31803, A479 S32750, B637 UNS-N07718 (Inconel 718)	1
5*	Seat insert	PVDF, DELRIN, PEEK, CF PEEK, PCTFE (KEL-F)	2
5A*	Seat housing	A479 316/316L, A350 LF2, B473 N08020, B164 N04400, B574 N06022, B574 N10276, A479 S31254, A479 S31803, A479 S32750	2
5B*	Seat seal	PTFE, Graphite, NBR, Viton	2
5C*	Seat seal (optional)	NBR, Viton	2

Item	Description	Material specification	Qty.
6*	Body seal	PTFE, Graphite, NBR, Viton	2
7*	Stem thrust seal	PEEK, CF PEEK, PCTFE (KEL-F), TFM ⁽²⁾ , CF PTFE ⁽²⁾	1
7a**	Anti-abrasion ring	PEEK, CF PEEK, PCTFE (KEL-F), TFM ⁽²⁾ , CF PTFE ⁽²⁾	1
8	Stop pin	A582 303	1
9*	Stem seal	CF PTFE, TFM, Graphite ⁽²⁾	1
10	Follower	B783 316L	1
10A*	Slide bearing	TF316	1
12	Stem nut	A194 8M, EN3506-2 A4-80	1
13	Tab lock washer	A240 304	1
14	Handle	C.St. Zinc plate, A240 316L	1
14A	Stop plate	C.St. 1.0402 Zinc plate, A240 430	1
14B	Wrench head	Ductile Iron A536 Gr. 65-45-12, A216 WCB, A351 CF8M	1
16	Wrench bolt	EN3506-1 A2-70/A4-80, A193 Gr B8/B8M	1
17	Sleeve	PVC	1
18	Body bolts	A193 B8M, EN3506-1 A4-80	16-30
20	Anti static spring	A313 302	2
21	Anti static plunger	A479 304	2
23	Tag (not shown)	A167 304	1

⁽¹⁾ 28 Series is Habonim's standard valve design without the HermetiX™ stem seal construction

⁽²⁾ This material can only be used as part of non HermetiX™ design

* Repair kit components

** Only with HermetiX™ stem seal

Floating Ball Valves

High pressure

General

24 Series

27 Series

28 Series

Ordering code system

Ordering code system

The Habonim high pressure ball valve identification code

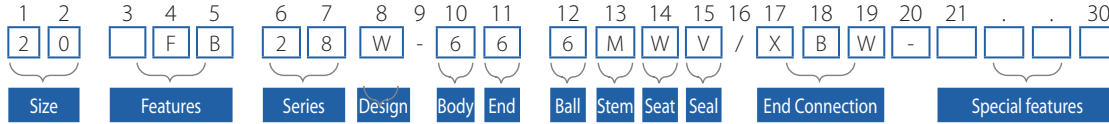

Size		
Code	inch	mm
02	¼"	8
03	⅜"	10
05	½"	15
07	¾"	20
10	1"	25
12	1¼"	32
15	1½"	40
20	2"	50
25	2½"	65
30	3"	80
40	4"	100
60	6"	150
80	8"	200

Seat / Seat Insert	
W	PVDF
Y	Delrin
K	CF PEEK
L	Virgin PEEK
C	PCTFE (KEL-F)

Seal	
B	NBR
V	Viton
T	PTFE
G	Expanded Graphite
I	Impregnated Graphite

End Connection	
Welded Ends	
XBW80	Extended butt weld ends (sch80)
XBW160	Extended butt weld ends (sch160)
XBWXS	Extended butt weld ends (sch XXS)
XSW	Extended socket weld ends

Body / End	
4	C. Steel A105
F	C. Steel LF2 A350 K03011
6	S. Steel 316L A479 S31603
7	Monel 400 B164 N04400
I	Inconel 625 B446 N06625
A	Alloy 20 B473 N08020
C	Alloy C276 B574 N10276
W	Alloy C22 B574 N06022
D	Duplex A479 S31803
K	Super Duplex A479 S32750
S	254SMO A479 S31254
4	C. Steel A105

End Connection	
Flanged RF	
1500	ANSI B16.5 #1500 RF
2500	ANSI B16.5 #2500 RF
PN160-F3	EN1092 PN160, FTF F3
PN250-F3	EN1092 PN250, FTF F3
PN320-F3	EN1092 PN320, FTF F3
PN400-F3	EN1092 PN400, FTF F3

Threaded Ends	
NPT	ASME B1.20.1 - National Pipe Taper thread
MNPT	Male NPT
BSPT	EN 10226-1 - British Standard Pipe Taper thread
DIN	EN 10226-1 - British Standard Pipe Parallel thread (Former DIN 2999)
DIN3852	DIN 3852 on-face gasket sealing threaded connection
AS5202	AS 5202 on-face gasket sealing threaded connection

Features	
A ⁽³⁾	Anti-Static
F	Fire safe
B	Full port
H ⁽³⁾	High pressure
R	Flush tank
O	Clean assembly for O ₂ service
I	High purity Class 10000 assembly room
M	Ammonia service
K	Chlorine service
V	Vacuum service

Ball	
6	S. Steel A351 316/316L, A479 316L
M	S. Steel 17-4PH A564 630 S17400
7	Monel 400 B164 N04400
Z	Inconel 718 B637 N07718
A	Alloy 20 B473 N08020
C	Alloy C276 B574 N10276
W	Alloy C22 B574 N06022
D	Duplex A479 S31803
K	Super Duplex A479 S32750
S	254SMO A479 S31254

Flanged RTJ	
1500RTJ	ANSI B16.5 #1500 RTJ
2500RTJ	ANSI B16.5 #2500 RTJ

Special stem seals	
LAX	Virgin PEEK thrust and TFM X shape gasket
CPX	PCTFE thrust and CF PTFE X shape gasket
CAX	PCTFE thrust and TFM X shape gasket
HYD	Hydrogen service
HC	High cycle service

Series	
24	Instrumentation valve #2500 up to 2" size
27	Three pieces valve #1500 / #2500
28	Three pieces valve with hybrid seats #2500

Stem	
M	S. Steel 17-4PH A564 630 S17400
7	Monel 400 B164 N04400
Z	Inconel 718 B637 N07718
W	Alloy C22 B574 N06022
D	Duplex A479 S31803
K	Super Duplex A479 S32750

Flanged SAE J518 / ISO 6162 Threaded	
SAE3000	Code 61/ISO 6162-1 Flat face
SAE6000	Code 62/ISO 6162-2 Flat face
SAE3000-61	Code 61/ISO 6162-1 Grooved face
SAE6000-62	Code 62/ISO 6162-2 Grooved face

Special features	
UB	Double NBR O-ring seat sealing (only for 28 series)
UV	Double Viton O-ring seat sealing (only for 28 series)
ACT	Ready for actuation (only for 24 series)
WR	DD stem
P250	Ball with upstream pressure relief hole
J2N05	Jacketed valve - number of ports (2), type (NPT) and size (½")

Flanged ISO	
ISO 6164 flange	ISO 6164 flange

In some applications the available options above are limited to specific sizes. Please consult with Habonim for details.

⁽¹⁾ DELRIN (Y) is Habonim default seat material for H.P. valves.

⁽²⁾ Due to high torque requirements, 17-4PH ball material (code 'M') shall be used.

⁽³⁾ Applicable for 24 and 27 series only.

The 28 Series Hybrid seats code system

14	23	24	25	25	
Hybrid Seat	Insert material	Upstream / Downstream	Insert Shape	Housing Shape + Seal Type	
F	C PCTFE	0 Hybrid seats on upstream and downstream, spring loaded	0 Scraper	0 U + Viton	
	K CF PEEK			1 U + NBR	
	L Virgin PEEK	1 Hybrid seats on upstream and downstream		5 L + Graphite	
	S VESPEL			6 L + PTFE	
	Y Delrin	5 Hybrid seats on upstream and metal seat on the downstream side		1 Round	
	W PVDF				

Hybrid Seat Types

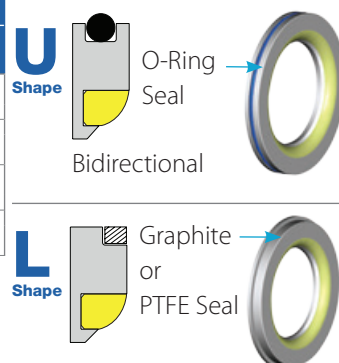

Insert Shapes

The "L shape" is mainly used for fire-safe or cryogenic applications where an elastomer O-ring cannot be used. The "U shape" housing allows for the use of O-ring elastomers for general purpose applications.



www.habonim.com

Habonim ISRAEL

Tel: +972-4-6914911

Fax: +972-4-6914935

sales_international@habonim.com

Habonim EUROPE

Tel: +34 640 384 759

sales_eu@habonim.com

Habonim UK

Tel: +44-1633-484554

Fax: +44-1633-482252

sales_uk@habonim.com

Habonim USA

Toll Free Phone: 1-866-261-8400

Toll Free Fax: 1-866-243-9959

sales_usa@habonim.com

Habonim CHINA

Tel: + 86 21 64453190 *146

sales_china@habonim.com

Habonim AUSTRALIA

Tel: +61 3 9556 5428

sales_au@habonimau.com



www.habonim.com

CAT-High pressures-MAIN 02/17 REV2.03

MAXMARK

