

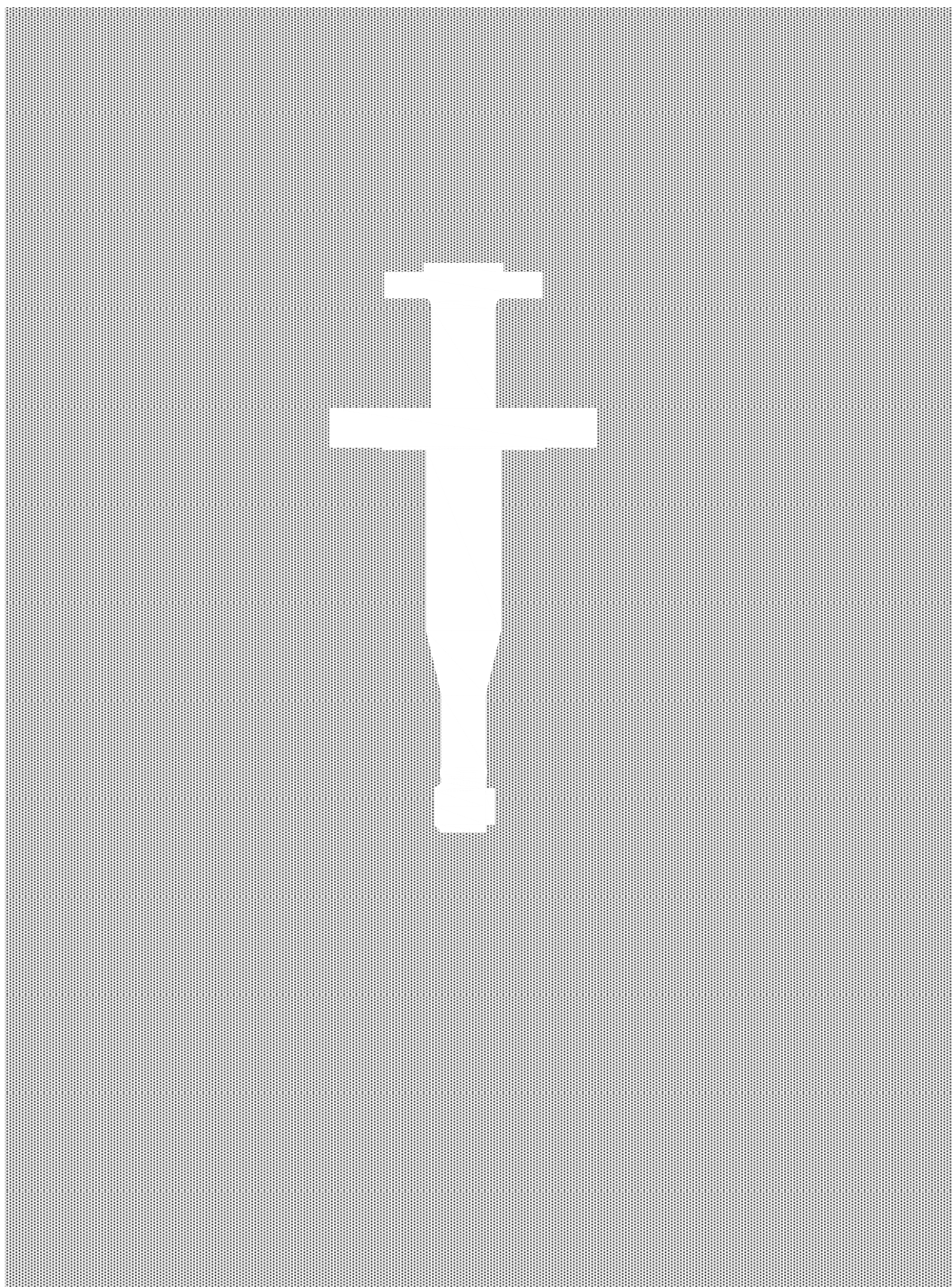

INSTRUCTIONS

For the installation fixed area DF desuperheaters





INSTRUCTIONS

For the installation fixed area DF desuperheaters

CONTENTS

	<i>Page</i>
1 General information	3
2 Warranty	3
3 Scope of these instructions	3
4 Safety signs.....	4
5 Notice on safety.....	5
6 Safety precautions.....	6
7 Installation.....	7
8 Maintenance.....	11
9 Removing the packaging.....	12
10 Repairs.....	12



INSTRUCTIONS

For the installation fixed area DF desuperheaters

1. GENERAL INFORMATION:

1.1 - RIGHT OF MODIFICATION AND COPYRIGHT

The regulations, standards etc. quoted in these instructions are valid at the time of preparation of this document and are not subsequently updated. It is the duty of the user to take full responsibility for applying the most up-to-date version of the standards and regulations in question.

The supplier reserves the right to make changes and technical improvements to data and information whenever it sees fit to do so. The user shall on no account be entitled to claim a right of modification or improvement in relation to valves already supplied.

2. WARRANTY

The extent and duration of the warranty are defined in the manufacturer's "General Conditions of Sale". The applicable conditions are those stipulated in the most up-to-date version in existence at the time of delivery.

The warranty does not cover, amongst other cases, damage to valves caused by the following:

- ° Ignorance of or non-compliance with these instructions for use!
- ° The work of personnel insufficiently qualified to undertake fitting, use or maintenance.
- ° Normal wear.
- ° Erroneous or negligent use of the valves.

The warranty shall not be valid and the manufacturer shall accept no responsibility in the event of:

- ° Non-compliance with regulations for the prevention of accidents and/or safety standards.
- ° Imperfect installation, poor commissioning and in correct use.
- ° Improper or incorrect use, inappropriate application or work conditions differing from those agreed.
- ° The user shall bear sole responsibility in the event of physical and/or material damage deriving from failure to observe the above.

3. SCOPE OF THESE INSTRUCTIONS

These instructions relate to **fixed area DF desuperheaters**.



20090 SEGRATE (MI)- via E.Fermi
EMAIL: info@carrarovalvole.it
TEL.(02) 269912.1 - FAX.(02) 2692.2452

IMI0034E.doc
Rev.1 28/04/15
Page 3 of 12



INSTRUCTIONS

For the installation fixed area DF desuperheaters

4. SAFETY SIGNS AND WARNINGS SYSTEM

Where appropriate, safety signs appear in the rectangular warning boxes in the margins of this manual. The rectangular warning boxes are laid out vertically (as shown in the examples below) and consist of four boxes containing messages highlighting:

- Level of seriousness
- Nature of the risk
- The consequences of interaction with the hazard for personnel or products
- Instructions, if necessary, on how to avoid the hazard

The top box contains a warning word (DANGER-WARNING-CAUTION-ATTENTION), which indicates the level of seriousness of the risk.

The central box contains a drawing indicating the nature of the hazard and the possible consequences, for personnel or property, of interaction with the hazard. In some cases of hazards to personnel, the drawing may suggest what preventive measures can be taken, such as wearing protective clothing, for example.

The bottom box may contain a message with instructions on how to avoid the hazard. In the case of hazards to personnel, the message may also contain a more precise definition of the hazard and its consequences for personnel.

- 1) **DANGER** - Immediate hazard, definitely capable of causing serious injury or death.
- 2) **WARNING** - Hazard or hazardous practice that could cause serious injury or death.
- 3) **CAUTION** - Hazard or hazardous practice that could cause mild injury.

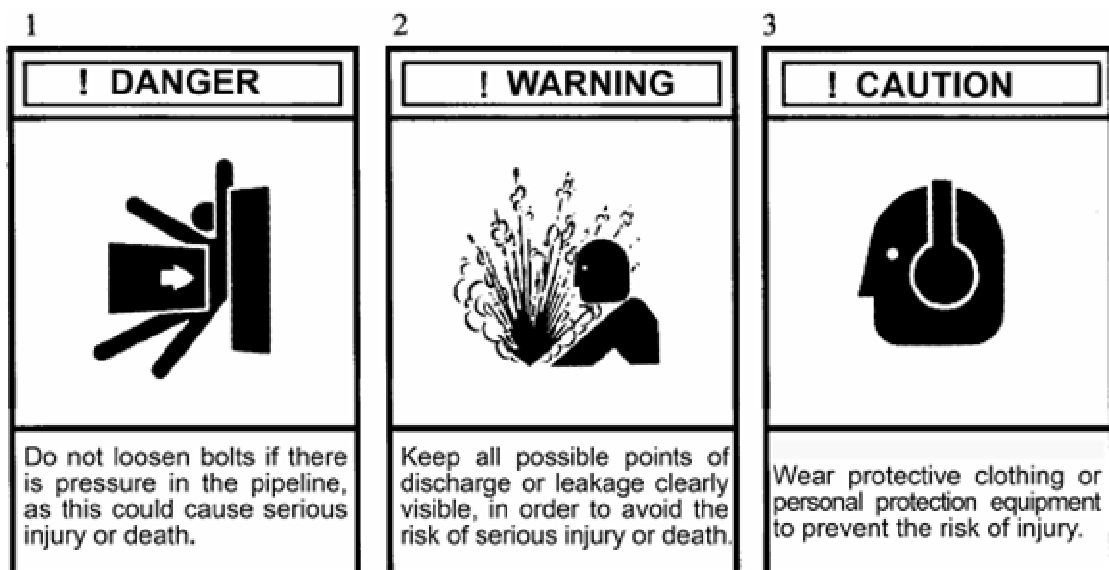



INSTRUCTIONS

For the installation fixed area DF desuperheaters

5. NOTICE ON SAFETY

Thorough checking and maintenance play a key role in ensuring the safe, reliable operation of all valves. The service procedures recommended by CARRARO and described in this manual constitute effective methods for performing the necessary maintenance operations. This service manual contains various warnings and invitations to take care, which must be read carefully in order to minimise the risk of injury to personnel and the possibility of adopting incorrect work methods which may damage the valves or make their operation unsafe. It is also important to note that these warnings can never be exhaustive.

CARRARO is not in a position to know, assess and warn customers or users of all the conceivable methods with which servicing may be carried out and all the potentially hazardous consequences of such methods.

CARRARO has not therefore attempted to undertake such a task. Anyone using a service procedure or tool not recommended by CARRARO must therefore make certain that neither their own safety nor that of other people, nor the safety or correct operation of the valve is put at risk by the chosen work method.

If in doubt about a given procedure, contact CARRARO for advice.

The testing, installation or disassembly of valves or accessories may lead to contact with fluid at high pressures or temperatures and/or corrosive or erosive fluid, and fluid capable of generating a potentially explosive atmosphere.

Comprehensive precautions must therefore be taken to prevent injury to personnel during testing, installation or removal; including, by way of example only: ear defenders, protective goggles, protective clothing such as gloves, etc., regardless of whether the persons in question are located directly in the work zone or in the surrounding area.

In view of the widely varying conditions and circumstances that may arise in relation to the operations to be carried out on products, and of the possible hazardous consequences of the way in which they are conducted, CARRARO is not in a position to foresee everything that might pose a risk of injury to persons or damage to property, and can therefore only offer, by way of assistance, this reminder to take care and a few suggestions (set out below) on safety precautions.

It is the responsibility of the user of CARRARO products to attend to the training of the personnel assigned to their use.

It is imperative that such personnel acquire a full knowledge of the instructions relating to the product and of this manual.





I N S T R U C T I O N S

For the installation fixed area DF desuperheaters

6. SAFETY PRECAUTIONS

! DANGER



Lower the pressure and keep at a safe distance from the outlet when working on a valve.

Always follow the safety regulations applicable to the plant and observe the following precautions:

- ° Wear protective clothing. Hot water causes burns and superheated vapour is invisible.

- ° When disassembling valves, wear protective clothing so as to prevent exposure to splashes of any process fluid that may be left inside the valves. Bear in mind that such fluid could generate a potentially explosive mixture.

Before starting disassembly, make certain that the valve is isolated from any source of pressure that may exist within the system.

! CAUTION



Wear the appropriate personal protection equipment to prevent possible injury.

- ° Carry out checking/maintenance of valves at least once every twelve months.

- ° The outer surfaces of valves reach temperatures approximately equal to the temperature of the fluid flowing through them. For this reason, if fitting a valve in a potentially explosive atmosphere, check that the explosion point of the atmosphere surrounding the valve is sufficiently higher than the temperature of the fluid handled by the system, and prevent deposits of dust from forming on the outside of the valve.

! WARNING



Keep all possible points of discharge or leakage clearly visible, in order to avoid the risk of serious injury or death.

- ° In the connection between the valve and line, ensure the equipotentiality of the system in order to prevent the accumulation of electro-static charges on the outer surfaces of the plant, which could act as an effective trigger in a potentially explosive atmosphere.

- ° Before carrying out any work on valve components, consult CARRARO.



INSTRUCTIONS

For the installation fixed area DF desuperheaters

7. INSTALLATION

Before installation, visually inspect the desuperheater to make certain that they are not damaged. Check that the information given in the documentation and on the data plate, and the tag number correspond to the specifications of the order. Remove the desuperheater from its package by lifting it with slings (for heavy loads) wrapped round its body. Do not remove the flange coverings until immediately before installation.

During installation of the desuperheater, use gaskets and fasteners which comply with the appropriate standards. Position the gasket on the mounting flange and gently insert the nozzle into the secondary pipe. Before tightening the studs, check that the spray cylinder is directed in the same direction as the vapour flow (make attention to the hole on the steam flange which indicates the direction of water flow).

The desuperheater must not be installed in such a way that it is subject to tensions, forces and torque.

The desuperheater has a standard body length as specified in the contractual drawings, whereas the mounting trunk of the vapour pipe must be made to measure. The length of this secondary pipe must be such that the central axis of the nozzle assembly corresponds with the central axis of the vapour line (± 5 mm).

The minimum length of tube required downstream varies according to application and is specified in the respective quote. This length without bends is necessary to prevent erosion caused by drops of water deposited on the walls of the pipes, the valves and the fittings, and is normally a minimum of 4m or 5DN (a straight length of pipe is not generally necessary upstream). The distance that separates the desuperheater from the temperature sensor is between 10 and 15 m, although the specific distance for the application is generally specified in the quote.

Longer distances ensure complete evaporation of the water at lower vapour speeds. The temperature sensor must be positioned in the top half of the pipe. Avoid fitting branches of the vapour pipe between the desuperheater and the sensor.

The supply water must be clean filtered and of excellent quality (e.g. boiler supply water) and must be at constant pressure at all times, as specified in the order documents. Each water supply line must be protected by its own filter with maximum mesh size of 0.1 mm. If closure components are envisaged in the water supply line, fit a safety valve of approved type. As for the vapour pipe, use gaskets and fasteners which comply with the codes of the respective pipes. Flush the water supply line before connecting the mounting flange of the desuperheater .



INSTRUCTIONS

For the installation fixed area DF desuperheaters

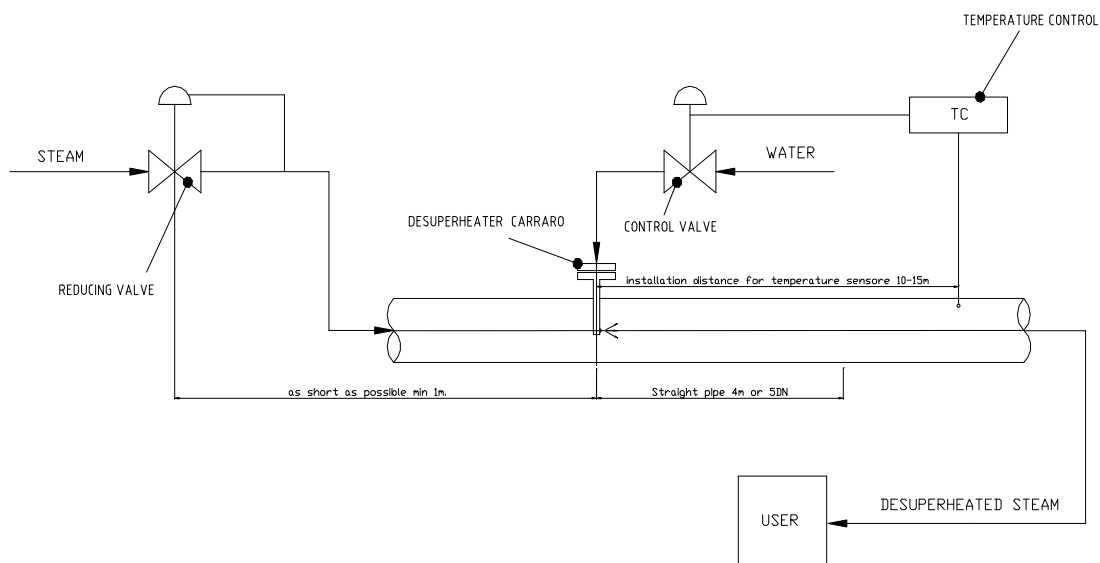

FIG.1 – SCHEMATIC PLANT

7.1 START-UP

Make sure that all the components are installed correctly. Calibrate the temperature control unit/transmitter in such a way that it responds automatically to temperature variations.

Heat the main vapour line and open the valve of the water supply line. Check the water pressure in the desuperheater and the operation of the transmitter and temperature control unit by manually increasing and reducing the output signal and observing the temperatures shown and recorded. Once there is satisfactory correspondence between the signals sent by the instruments and the actual temperature, it is possible to set the regulation point and activate the system in automatic mode.

You are advised to record the various coordinates of the vapour over a sufficiently long period, in order to check the operation of the system and make the necessary modifications.



ISTRUZIONI

For the installation fixed area DF desuperheaters

PROBE TYPE

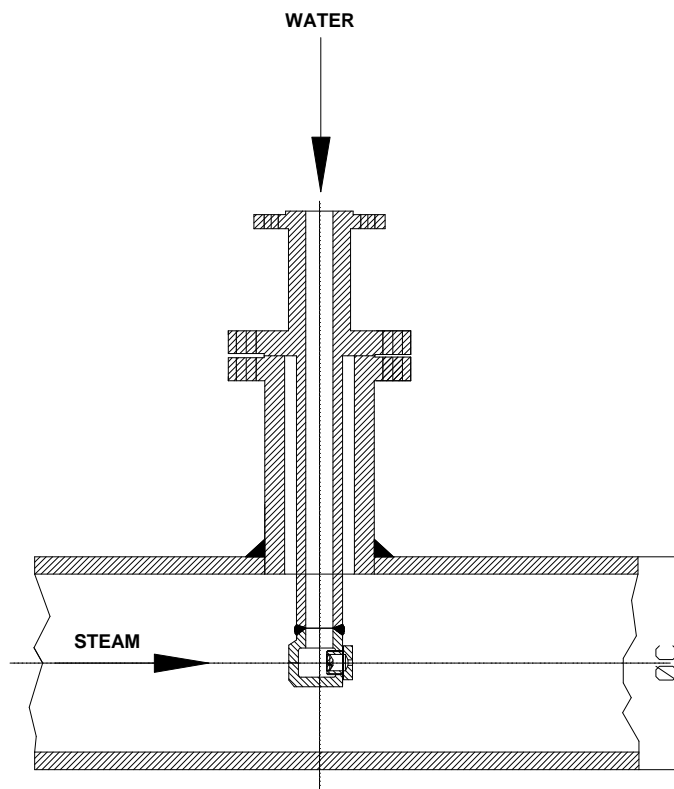



ISTRUZIONI

For the installation fixed area DF desuperheaters

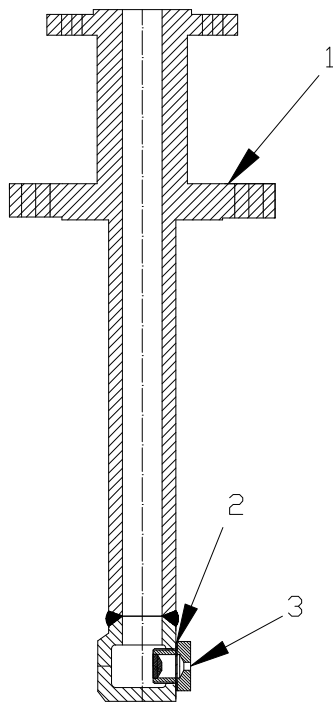

FIG. 2 – ASSEMBLY VARIFIX PROBE TYPE

ITEM	PART NAME
1	Body
2	Locking washer
3	Nozzle

8 MAINTENANCE



20090 SEGRATE (MI)- via E.Fermi
EMAIL: info@carrarovalvole.it
TEL.(02) 269912.1 - FAX.(02) 2692.2452

IMI0034E.doc
Rev.1 28/04/15
Page 10 of 12



INSTRUCTIONS

For the installation fixed area DF desuperheaters

Maintenance of the desuperheater is extremely simple and does not require specific instruments or knowledge. Take extreme care when carrying out maintenance work, especially if using honing machines, compressed air and rotary machinery. It is imperative to wear goggles, gloves and other protective equipment, in accordance with the applicable safety procedures.

8.1 REMOVAL

Before removing the desuperheater from the system, check that the vapour and water pipes are completely depressurised, drained and bled. Slacken the studs on the water and vapour flange and remove the desuperheater from the system. It is advisable to move the unit to a workshop equipped with workbench and vice. Lift the unit using suitable slings wrapped round its body.

8.2 DISASSEMBLY AND RE-ASSEMBLY

The desuperheater can be disassembled more easily if it is positioned horizontally with the section of the body extension firmly gripped in the vice. Nozzle and locking washer are spare parts. To replace the nozzle (see part 3 in FIG2) is sufficient to unscrew it forcing the locking washer. Then screw the new nozzle and bend the new locking washer in the hole and on the the nozzle. Provide to reinstall the desuperheater in the correct position. Take care to the hole on the steam flange that indicate the direction of injection.

NB: In version DF1525 and DF1550 (see FIG.3), before to replace the nozzle head, cut the tack welds, unscrew the fastener ring (6) and the nozzle assembly (4+5). Re-lap the tight surface on the pipe(7) if necessary. Take care that the screw on the nozzle head(5) is left hand while on the extension (7) it's right hand. To facilitate removal of the ring, tap it gently with a hammer. Take care not to damage the thread of the body and of the cylinder. Once re-assembled, weld the spray cylinder(4+5) for improved safety. It is imperative that this operation be undertaken by a competent welder. A welding procedure specification is available from Carraro on request. Both TIG and ARC welding are acceptable, and the recommended electrode material is ER NiCrMo3. At least 2 welds are necessary. They must be 8 mm in length and diametrically opposed. One weld must secure the fastener ring to the body extension, and the other must secure the spray cylinder to the fastener ring. On completion, check the welding using appropriate penetrating liquids. There must be no cracks. If necessary, grind and check again until the weld is satisfactory (see Fig.4). Before reinstalling check that the direction of the injection is the same of the hole on the steam flange and then take care to the correct reinstalling on the steam pipe.

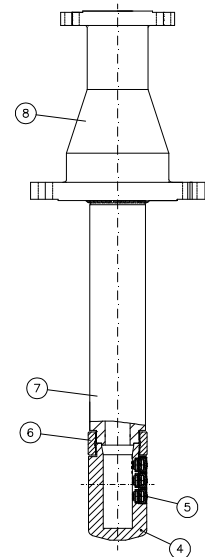

FIG.3

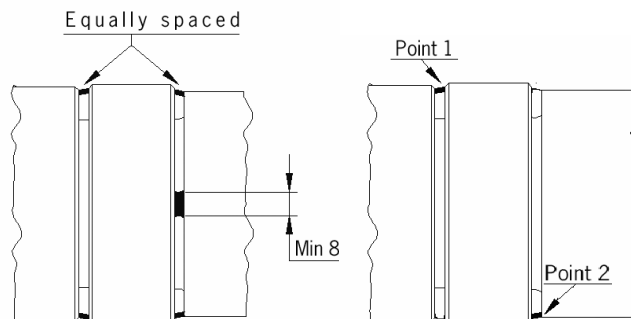

FIG.4



INSTRUCTIONS

For the installation fixed area DF desuperheaters

9 REMOVING THE PACKAGING

Carraro desuperheaters are packed with the most care in wooden crates or cardboard boxes so that they are protected during handling and transport to their place of installation. After hydrostatic testing, the desuperheater is flushed through with a protective agent formulated to protect the internal surfaces against corrosion. Should any damage occur during transport, however, the transport company or a representative of Carraro must be notified immediately. Remove the packaging with care, then check that the surfaces of the flanges, threads, connection pipes, etc. are not damaged.

10 REPAIRS

- 10.1 If it's not possible to eliminate the problems, send faulty desuperheater to the supplier/manufacturer, together with a description of the problem.
- 10.2 In order to receive spare parts or information, always indicate the serial number shown on the rating plate attached to the valve or punched on the outer surface of the flanges.
- 10.3 To ensure the valves treated in this manual work correctly, they should be serviced by Carraro engineers or by Carraro-authorized Service Centres using original spare parts.



ATTENTION!

The maker declines all liability for modifications to the product or operations that are not contemplated in this manual