

General Specifications

GS 12A01A02-71E

Model FLXA21
2-Wire Analyzer
FOUNDATION Fieldbus
Communication

■ General

FOUNDATION Fieldbus is the digital communication line for the field instruments, whose signal is internationally standardized by Fieldbus Foundation.

The Fieldbus bi-directional digital communication performance makes possible for the field instruments and the control devices to be a complete on-line system, superseding the existing analog transmission lines.

Vendor-independence and openness allow communication between devices of different manufactures with no special interface adjustment.

FLXA™21 FOUNDATION Fieldbus model offers more flexible instrumentation through a higher level communication capability and proposes the cost reduction by multidrop wirings with fewer cables.

In the FLXA21 Human Machine Interface (HMI), 2-wire type analyzer FLXA21 offers easy touch screen operation and simple menu structure in 12 languages. Menus of display, execution and setting are displayed in a selected language.

The analyzer FLXA21 automatically recognizes the installed sensor module and prepares the necessary menus for right configuration.

For immediate measurement, the FLXA21 offers quick setup functionality. The quick setup screen appears when the analyzer is powered. Only a few setups – date/time, language, basic sensor configurations and output – will start the measurement.

The FLXA21 offers the best accuracy in measurement with temperature compensation functionality and calibration functionality. Sensor diagnostics and sensor wellness indication make measurement reliable. Logbook of events and diagnostic data is a useful information source for maintenance.

■ Features

- Interoperability
FOUNDATION Fieldbus specifications grant the interoperability of the field instruments without preparing designated software for the instrument.
- Multi-sensing function
FLXA21 FOUNDATION Fieldbus model, has three independent AI function blocks.
- Alarm function
FLXA21 FOUNDATION Fieldbus model securely supports various alarm functions, such as high/low alarm, notice of block error, etc. based on Fieldbus specifications.



- Link master function
FLXA21 FOUNDATION Fieldbus model support the Link Master function. This function enables backup of network manager and local control only by field devices.
- Self-diagnostic function
A reliable self-diagnostic function based on the NAMUR NE107 standard detects failures in the hardware of pH/ORP sensor, conductivity sensor, and communications.
- 2 kinds of measurements; pH/ORP, Conductivity (SC)
- Simple HMI menu structure in 12 languages
- Quick setup menu for immediate measurement
- Indication of sensor wellness
- Software download function
Software download function permits to update FLXA21 software via a FOUNDATION fieldbus. Typical use of this function is to add new features such as function blocks and diagnostics to existing devices
- Supported tools
DTM for FieldMate™
FLXA21 FOUNDATION Fieldbus model can be connected with DeltaV/AMS by EMERSON Process Management.
This device can't be connected with DeltaV 9.3 / AMS 9 and older version of them.
Version of them are follows:
DeltaV 10.3 / AMS 10.5
DeltaV 11.3 / AMS 11.5
DeltaV 12.3 / AMS 12.5
DeltaV 13.3 / AMS 13.0

FLEXA, FLXA and FieldMate are trademarks or registered trademarks of Yokogawa Electric Corporation.

All other company and product names mentioned in this document are trademarks or registered trademarks of their respective companies. We do not use TM or © mark to indicate those trademarks or registered trademarks in this document.

■ General Specifications

1. Basic

■ Measurement Object/Sensor Type

- pH/Oxidation-reduction Potential (pH/ORP)
- Conductivity (SC)

Note: The available measurement object depends on a sensor module installed on the analyzer.

■ Analyzer Structure

Module structure

● Composition of Analyzer

- One (1) Housing assembly
- One (1) Sensor module

2. Measurement

2-1. pH/Oxidation-reduction Potential (pH/ORP)

■ Input Specification

Dual high impedance input ($\geq 10^{12} \Omega$)

■ Input Range

pH: -2 to 16 pH
 ORP: -1500 to 1500 mV
 rH: 0 to 100 rH

Temperature:

Pt1000: -30 to 140 °C
 Pt100: -30 to 140 °C
 6k8: -30 to 140 °C
 PTC10k: -30 to 140 °C
 NTC 8k55: -10 to 120 °C
 3k Balco: -30 to 140 °C
 PTC500: -30 to 140 °C

■ Performance (Accuracy)

(The specifications are expressed with simulated inputs.)

pH

Linearity: ± 0.01 pH
 Repeatability: ± 0.01 pH
 Accuracy: ± 0.01 pH

ORP

Linearity: ± 1 mV
 Repeatability: ± 1 mV
 Accuracy: ± 1 mV

Temperature

with Pt1000, 6k8, PTC10k, NTC 8k55, 3k Balco, PTC500

Repeatability: ± 0.1 °C
 Accuracy: ± 0.3 °C

with Pt100

Linearity: ± 0.4 °C
 Repeatability: ± 0.1 °C
 Accuracy: ± 0.4 °C

2-2. Conductivity (SC)

■ Input Specification

Two or four electrodes measurement with square wave excitation, using max 60m (200ft) cable (WU40/WF10) and cell constants from 0.005 to 50.0 cm^{-1}

■ Input Range

Conductivity:

min.: 0 $\mu\text{S}/\text{cm}$
 max.: 200 $\text{mS} \times (\text{Cell constant})$
 (over range 2000 mS/cm)

Resistivity:

min.: 0.005 $\text{k}\Omega / (\text{Cell constant})$
 max.: 1000 $\text{M}\Omega \times \text{cm}$

Temperature:

Pt1000: -20 to 250 °C
 Pt100: -20 to 200 °C
 Ni100: -20 to 200 °C
 NTC 8k55: -10 to 120 °C
 Pb36(JIS NTC 6k): -20 to 120 °C

■ Performance (Accuracy)

(The specifications are expressed with simulated inputs.)

Conductivity

More than 2 $\mu\text{S} \times \text{K} \text{cm}^{-1}$ to 200 $\text{mS} \times \text{K} \text{cm}^{-1}$
 Accuracy: $\pm 0.5\%$ of reading
 1 $\mu\text{S} \times \text{K} \text{cm}^{-1}$ to 2 $\mu\text{S} \times \text{K} \text{cm}^{-1}$
 Accuracy: $\pm 1\%$ of reading

Resistivity

0.005 $\text{k}\Omega / \text{K} \text{cm}^{-1}$ to less than 0.5 $\text{M}\Omega / \text{K} \text{cm}^{-1}$
 Accuracy: $\pm 0.5\%$ of reading
 0.5 $\text{M}\Omega / \text{K} \text{cm}^{-1}$ to 1 $\text{M}\Omega / \text{K} \text{cm}^{-1}$
 Accuracy: $\pm 1\%$ of reading

Temperature

with Pt1000, Pb36, Ni100
 Accuracy: ± 0.3 °C
 with Pt100, NTC 8k55
 Accuracy: ± 0.4 °C

Temperature compensation

NaCl table: $\pm 1\%$
 Matrix: $\pm 3\%$

Step response: 90% (<2 decades) in 7 seconds (of reading on the display)

Note: "K" means cell constant.

YOKOGAWA provides conductivity sensors of which cell constants are 0.1 to 10 cm^{-1} .

3. Electrical

■ Output Signal

Digital communication signal based on FOUNDATION Fieldbus protocol.

■ Communication Requirements:

Supply Voltage: 9 to 32 V DC
 Current Draw: 24 mA (max)
 Bus connection and Fieldbus cable type according to recommendation based on IEC 1158-2.

■ Functional Specifications:

Functional specifications for Fieldbus communication conform to the standard specifications (H1) of FOUNDATION fieldbus.

DD and CFF: The actual file can be downloaded from www.fieldbus.com

■ Function Block:

Three AI blocks

■ Display

LCD with a touch screen:

Black/White: 213 x 160 pixels

Contrast adjustment available on the touch screen

Message language:

12 (English, Chinese, Czech, French, German, Italian, Japanese, Korean, Polish, Portuguese, Russian and Spanish)
 One analyzer has all 12 languages.

Note: Description for a selection of language and language names are written in English.

Note: Only English alphabet and numeric are available for a tag number, an additional description for each value on the display screen and passwords.

Note: Only for message language on the screen, 12 languages are provided.

4. Mechanical and others

■ Housing

Case: Plastic (Polycarbonate)
 Case color: Silver gray (equivalent to Munsell 3.2PB7.4/1.2)
 Window: Polycarbonate (flexible)
 Protection: IP66 (except Canada), NEMA Type 4X (USA), CSA Type 3S/4X (Canada)

■ Plate

Main name plate: inside case cover
 Regulation plate: on the case outside

■ Cable and Terminal

Cable size:
 Outer diameter:
 6 to 12 mm (suitable for M20 cable gland)
 3.4 to 7 mm (grounding cable)
 Terminal screw size: M4
 torque of screw up: 1.2 N·m
 Wire terminal:
 Pin terminal, ring terminal and spade terminal can be used for analyzer's power supply terminals and sensor terminals.
 Pin terminal: pin diameter: max. 1.9 mm
 Ring and spade terminal: width: max. 7.8 mm

■ Cable Entry

3 holes, M20 cable gland x 3 pcs,
 Sleeve x 1 pc (for grounding cable line)
 Note: Cable glands are delivered with an analyzer, but not assembled into the analyzer.

■ Mounting

Mounting hardware (option):
 • Universal mounting kit (Note)
 • Pipe and wall mounting hardware
 • Panel mounting hardware

Note: This kit contains the pipe and wall mounting hardware and the panel mounting hardware.

Hood (option):

- Stainless steel
- Stainless steel with urethane coating
- Stainless steel with epoxy coating

■ Stainless Steel Tag Plate

When the additional code "/SCT" with a tag number is specified, the tag plate on which the tag number is inscribed is delivered with the analyzer.

Tag plate is hanging type.

■ Conduit Adapter

Using optional adapter
 • G1/2 (quantity: 4)
 • 1/2NPT (quantity: 4)
 • M20 x 1.5 (quantity: 4)

These conduit adapters are delivered with an analyzer, but not assembled into the analyzer.

■ Size of Housing Case

144 x 144 x 151 mm (W x H x D) (without cable gland)

■ Weight

Approx. 1 kg

■ Ambient Operating Temperature

-20 to +55 °C

■ Storage Temperature

-30 to +70 °C

■ Humidity

10 to 90% RH at 40°C (Non-condensing)

■ Regulatory Compliance

■ Safety, EMC and RoHS Compliance

Safety: UL 61010-1
 UL 61010-2-030
 CAN/CSA-C22.2 No.61010-1
 CAN/CSA-C22.2 No.61010-2-030
 EN 61010-1
 EN 61010-2-030
 EMC: EN 61326-1 Class A, Table 2 (For use in industrial locations)
 EN 61326-2-3
 EN 61326-2-5
 RCM: EN 61326-1 Class A, Table 2
 Korea Electromagnetic Conformity Standard Class A 한국 전자파적합성 기준

RoHS: EN IEC 63000 (Style 3.06 and later)

Installation altitude: 2000 m or less

Category based on IEC 61010: I (Note 1)

Pollution degree based on IEC 61010: 2 (Note 2)

Note 1: Installation category, called over-voltage category, specifies impulse withstand voltage.

Equipment with "Category I" (ex. two wire transmitter) is used for connection to circuits in which measures are taken to limit transient over-voltages to an appropriately low level.

Note 2: Pollution degree indicates the degree of existence of solid, liquid, gas or other inclusions which may reduce dielectric strength. Degree 2 is the normal indoor environment.

Information of the WEEE Directive

This product is purposely designed to be used in a large scale fixed installations only and, therefore, is out of scope of the WEEE Directive. The WEEE Directive does not apply. The WEEE Directive is only valid in the EU.

■ Explosion Protected Type Compliance

Item	Description	'Type' in MS code
Europe (ATEX)	<p>[Intrinsic safety "ia"] Applicable Standard: EN IEC 60079-0, EN 60079-11 Certificate No: DEKRA 11ATEX0109X Marking/Rating:  II 1 G Ex ia IIC T4 Ga, FISCO field device Ambient Temperature: -20 to 55°C Power Supply / Signals: See the control drawing. Electrical parameters: See the control drawing. Dielectric strength: 500 V a.c. r.m.s. between - Supply terminals and the earth terminal - the terminals of Measuring Modules excluding PH, SC and ISC and the earth terminal - Supply terminals and the terminals of Measuring Modules - the terminals of Measuring Module 1 and the terminals of Measuring Module 2 700 V d.c. between - the terminals of PH, SC and ISC Measuring Modules and the earth terminal Specific conditions of use: Electrostatic charges on the non-metallic or coated parts of the two wire analyzer shall be avoided. Since the enclosure of the Model FLXA202 is made of aluminium, if it is mounted in an area where the use of EPL Ga (category 1 G) equipment is required, it shall be installed such that, even in the event of rare incidents, ignition sources due to impact and friction sparks are excluded. On-site assembling: See Use's Manual IM 12A01A03-01EN. Installation and erection: See the control drawing. Maintenance and Repair: Warning: A modification of the equipment would no longer comply with the construction described in the certificate documentation. Only personnel authorized by Yokogawa Electric Corporation can repair the equipment. Control Drawing: Refer to (1)</p>	-CB
International (IECEx)	<p>[Intrinsic safety "ia"] Applicable Standard: IEC 60079-0, IEC 60079-11 Certificate No: IECEx DEK 11.0044X Marking/Rating: Ex ia IIC T4 Ga, FISCO field device Ambient Temperature: -20 to 55°C Power Supply / Signals: See the control drawing. Electrical parameters: See the control drawing. Dielectric strength: 500 V a.c. r.m.s. between - Supply terminals and the earth terminal - the terminals of Measuring Modules excluding PH, SC and ISC and the earth terminal - Supply terminals and the terminals of Measuring Modules - the terminals of Measuring Module 1 and the terminals of Measuring Module 2 700 V d.c. between - the terminals of PH, SC and ISC Measuring Modules and the earth terminal Specific conditions of use: Electrostatic charges on the non-metallic or coated parts of the two wire analyzer shall be avoided. Since the enclosure of the Model FLXA202 is made of aluminium, if it is mounted in an area where the use of EPL Ga (category 1 G) equipment is required, it shall be installed such that, even in the event of rare incidents, ignition sources due to impact and friction sparks are excluded. On-site assembling: See Use's Manual IM 12A01A03-01EN. Installation and erection: See the control drawing. Maintenance and Repair: Warning: A modification of the equipment would no longer comply with the construction described in the certificate documentation. Only personnel authorized by Yokogawa Electric Corporation can repair the equipment. Control Drawing: Refer to (1)</p>	

Item	Description	'Type' in MS code
United States (FM)	<p>[Intrinsically safe / Nonincendive]</p> <p>Applicable Standard: FM 3600, FM3610, FM3611, FM3810, NEMA 250, ANSI/ISA 60079-0, ANSI/ISA 60079-11, ANSI/UL 121201, ANSI/ISA 61010-1</p> <p>Certificate No: FM20US0046X</p> <p>Marking/Rating: IS CL I, DIV 1, GP ABCD CL I, ZN 0, AEx ia IIC NI CL I, DIV 2, GP ABCD CL I, ZN 2 IIC FISCO field device</p> <p>T4: for ambient temperature: -20 to 55°C</p> <p>Enclosure: Type 4X</p> <p>Power Supply / Signals: See the control drawing.</p> <p>Battery: No replaceable battery</p> <p>Electrical parameters: See the control drawing.</p> <p>Dielectric strength: 500 V AC, r.m.s. between - Supply terminals and the earth terminal - the terminals of Measuring Modules excluding PH, SC and ISC and the earth terminal - Supply terminals and the terminals of Measuring Modules - the terminals of Measuring Module 1 and the terminals of Measuring Module 2 700 V DC between - the terminals of PH, SC and ISC Measuring Modules and the earth terminal</p> <p>Specific conditions of use: See the control drawings.</p> <p>On-site assembling: See Use's Manual IM 12A01A03-01EN.</p> <p>Installation and erection: See the control drawing.</p> <p>Maintenance and Repair: Warning: A modification of the equipment would no longer comply with the construction described in the certificate documentation. Only personnel authorized by Yokogawa Electric Corporation can repair the equipment.</p> <p>Control Drawing: Refer to (3)</p>	-CD
Canada (CSA)	<p>[Intrinsically safe / Nonincendive]</p> <p>Applicable Standard: C22.2 No.0, CAN/CSA-C22.2 No.94, C22.2 No.213, CAN/CSA-C22.2 No.60079-0, CAN/CSA-C22.2 No.60079-11, CAN/CSA-C22.2 No.61010-1, CAN/CSA-C22.2 No.61010-2-030</p> <p>Certificate No: 2425510</p> <p>Marking/Rating: Ex ia IIC T4 Ga, FISCO field device Intrinsically safe for Class I, Division 1, Groups A, B, C, D, T4 Nonincendive for Class I, Division 2, Groups A, B, C, D, T4</p> <p>Ambient Temperature: -20 to 55°C</p> <p>Ambient Humidity: 0 – 100% (No Condensation)</p> <p>Enclosure: IP66, NEMA 4X</p> <p>Power Supply / Signals: See the control drawing.</p> <p>Battery: No replaceable battery</p> <p>Electrical parameters: See the control drawing.</p> <p>Dielectric strength: 500 V AC, r.m.s. between - Supply terminals and the earth terminal - the terminals of Measuring Modules excluding PH, SC and ISC and the earth terminal - Supply terminals and the terminals of Measuring Modules - the terminals of Measuring Module 1 and the terminals of Measuring Module 2 700 V DC between - the terminals of PH, SC and ISC Measuring Modules and the earth terminal</p> <p>Specific conditions of use: See the control drawings.</p> <p>On-site assembling: See Use's Manual IM 12A01A03-01EN.</p> <p>Installation and erection: See the control drawing.</p> <p>Maintenance and Repair: Warning: A modification of the equipment would no longer comply with the construction described in the certificate documentation. Only personnel authorized by Yokogawa Electric Corporation can repair the equipment.</p> <p>Control Drawing: Refer to (2)</p>	

Item	Description	'Type' in MS code
United States (FM)	<p>[Nonincendive]</p> <p>Applicable Standard: FM 3600, FM3611, FM3810, NEMA 250, ANSI/UL 121201, ANSI/ISA 61010-1</p> <p>Certificate No: FM20US0046X</p> <p>Marking/Rating: NI CL I, DIV 2, GP ABCD ZN 2 IIC</p> <p>T4: for ambient temperature: -20 to 55°C</p> <p>Enclosure: Type 4X</p> <p>Power Supply / Signals: See the control drawing.</p> <p>Battery: No replaceable battery</p> <p>Electrical parameters: See the control drawing.</p> <p>Dielectric strength:</p> <p>500 V AC, r.m.s. between</p> <ul style="list-style-type: none"> - Supply terminals and the earth terminal - the terminals of Measuring Modules excluding PH, SC and ISC and the earth terminal - Supply terminals and the terminals of Measuring Modules - the terminals of Measuring Module 1 and the terminals of Measuring Module 2 <p>700 V DC between</p> <ul style="list-style-type: none"> - the terminals of PH, SC and ISC Measuring Modules and the earth terminal <p>Specific conditions of use: See the control drawings.</p> <p>On-site assembling: See Use's Manual IM 12A01A03-01EN.</p> <p>Installation and erection: See the control drawing.</p> <p>Maintenance and Repair:</p> <p>Warning: A modification of the equipment would no longer comply with the construction described in the certificate documentation.</p> <p>Only personnel authorized by Yokogawa Electric Corporation can repair the equipment.</p> <p>Control Drawing: Refer to (3)</p>	-DD
Canada (CSA)	<p>[Nonincendive]</p> <p>Applicable Standard: C22.2 No.0, CAN/CSA-C22.2 No.94, C22.2 No.213, CAN/CSA-C22.2 No.61010-1, CAN/CSA-C22.2 No.61010-2-030</p> <p>Certificate No: 2425510</p> <p>Marking/Rating: Nonincendive for Class I, Division 2, Groups A, B, C, D, T4</p> <p>Ambient Temperature: -20 to 55°C</p> <p>Ambient Humidity: 0 – 100% (No Condensation)</p> <p>Enclosure: IP66, NEMA 4X</p> <p>Power Supply / Signals: See the control drawing.</p> <p>Battery: No replaceable battery</p> <p>Electrical parameters: See the control drawing.</p> <p>Dielectric strength:</p> <p>500 V AC, r.m.s. between</p> <ul style="list-style-type: none"> - Supply terminals and the earth terminal - the terminals of Measuring Modules excluding PH, SC and ISC and the earth terminal - Supply terminals and the terminals of Measuring Modules - the terminals of Measuring Module 1 and the terminals of Measuring Module 2 <p>700 V DC between</p> <ul style="list-style-type: none"> - the terminals of PH, SC and ISC Measuring Modules and the earth terminal <p>Specific conditions of use: See the control drawings.</p> <p>On-site assembling: See Use's Manual IM 12A01A03-01EN.</p> <p>Installation and erection: See the control drawing.</p> <p>Maintenance and Repair:</p> <p>Warning: A modification of the equipment would no longer comply with the construction described in the certificate documentation.</p> <p>Only personnel authorized by Yokogawa Electric Corporation can repair the equipment.</p> <p>Control Drawing: Refer to (2)</p>	
China (NEPSI)	<p>[Intrinsic safety "ia"]</p> <p>Applicable Standard: GB3836.1-2010, GB3836.4-2010, GB 3836.20-2010</p> <p>Certificate No: GYJ18.1051X</p> <p>Marking/Rating: Ex ia IIC T4 Ga, FISCO field device</p> <p>Ambient Temperature: -20 to 55°C</p> <p>Control Drawing: Refer to (4)</p>	-CH
Korea (KCs)	<p>[Intrinsic safety "ia"]</p> <p>Applicable Standard: Notice of Ministry of Labor No. 2016-54</p> <p>Certificate No: 15-AV4BO-0160X</p> <p>Marking/Rating: Ex ia IIC T4, FISCO field device</p> <p>Ambient Temperature: -20 to 55°C</p> <p>Control Drawing: Refer to (4)</p>	-EG

Yokogawa Electric Corporation		Model		FLXA21	
Title		Control drawing (FOUNDATION Fieldbus / PROFIBUS PA type)			
No.	IKE039-A32	Page	1	Revision	0
		Date	2019-10-18		

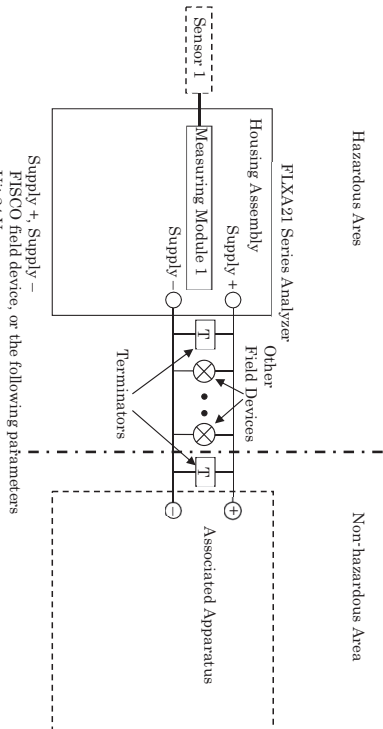

Supply + Supply -
PISCO field device, or the following parameters
 U_I: 24 V
 I_I: 250 mA
 P_I: 1.2 W
 C_E: 2.72 nF
 L_I: 0 mH

Measuring Module 1

	Type of Measuring Module	
	pH, SC, DO	ISC
		SENGOM
U ₀	11.76 V	11.76 V
I ₀	116.5 mA	60.6 mA
P ₀	0.3424 W	0.178 W
C ₀	100 nF	100 nF
L ₀	1.7 mH	8 mH
		0.45 mH

Notes:

1. The associated apparatus must be a linear source or a PISCO power supply.
2. Sensor 1 may be simple apparatus or intrinsically safe apparatus.
3. When accessing the display window or other non-metallic parts of the enclosure of FLXA21, take the following measures to minimize the risk of explosion from electrostatic discharges, in addition to avoiding any actions that cause the generation of electrostatic charges, such as rubbing with a dry cloth.

To avoid electrostatic charge on the operator,

- Earth the operator through a wrist-strap, or
 - Operate FLXA21 on the conductive floors, wearing anti-static work clothes and electrostatic safety shoes, or
 - Neutralize the operator and FLXA21 by a static elimination bar which has a metal part earthed through resistor from 100kΩ to 100MΩ.
- In case that those measures cannot be taken or static electricity cannot be suppressed, bring a gas detector and make sure there is no ignition capable atmosphere around FLXA21 before the operation.

DEKRA Certification B.V.
 Measuring Module 1
 P.O. Box 5185, 6807 FD Arnhem

■ Control Drawings

(1) ATEX and IECEx Intrinsic safety "ia"

Model: FLEXA Series

Date: April 17, 2015

Control drawing (FOUNDATION Fieldbus / PROFIBUS PA type)

Installation for Division 1 / Zone 0, 1

Applicable models: FLXA21-D-x-x-CD-xxxx-F..., FLXA21-D-x-x-CD-xxxx-P...

Hazardous (Classified) Location
 Class I, Division 1, Groups A, B, C, D, or
 Class I, Zone 0, 1, Group IIC
 Temperature Class: T4

Unclassified Location

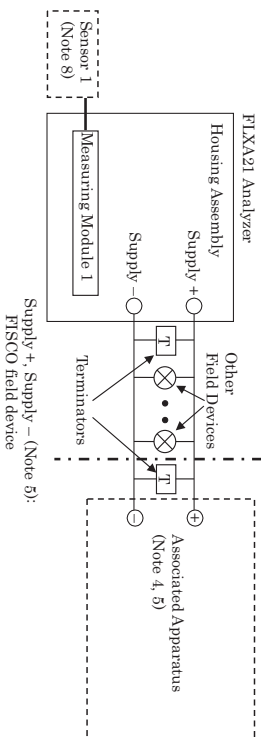

Supply +, Supply - (Note 5):
 FTSCO field device
 or
 Ui: 24 V
 Ii: 250 mA
 Pi: 1.2 W
 Ci: 2.72nF
 Li: 0 mH

Measuring Module 1 (Note 8):

Type of Measuring Module	
pH, SG, DO	ISC SENCOM
Uo	11.76 V 11.76 V 5.36 V
Io	116.5 mA 60.6 mA 106.16 mA
Po	0.3424 W 0.178 W 0.1423 W
Co	100 nF 100 nF 31 μF
Lo	1.7 mH 8 mH 0.45 mH

- Specific condition of use
- Precautions shall be taken to minimize the risk of non-metallic parts and painted parts of the enclosure. When the equipment is used in hazardous locations, avoid any action which generates electrostatic discharge such as rubbing with a dry cloth.

Rev.2: Dec. 26, 2019

Yokogawa Electric Corporation

Doc. No.: IFM039-A72 P.1

(2) FM Intrinsic safety, Nonincendive

Model: FLEXA Series

Date: April 17, 2015

Installation for Division 2 / Zone 2

Applicable models: FLXA21-D-x-x-CD-xxxx-F..., FLXA21-D-x-x-CD-xxxx-P...,
 FLXA21-D-x-x-DD-xxxx-F..., FLXA21-D-x-x-DD-xxxx-P...

Hazardous (Classified) Location
 Class I, Division 2, Groups A, B, C, D, or
 Class I, Zone 2, Group IIC,
 Temperature Class: T4

Unclassified Location

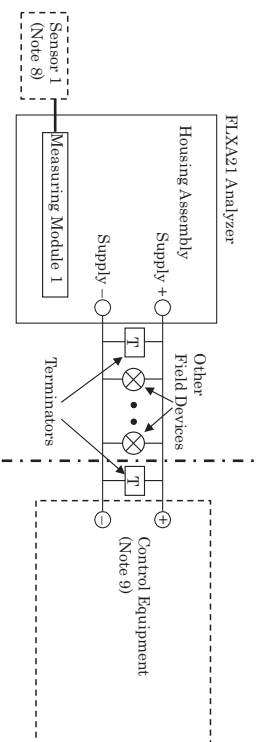

Supply +, Supply - (Note 9):
 Ui: 24 V
 Ci: 2.72 nF
 Li: 0 mH

Measuring Module 1 (Note 8):

Type of Measuring Module	
pH, SG, DO	ISC SENCOM
Uo	11.76 V 11.76 V 5.36 V
Io	116.5 mA 60.6 mA 106.16 mA
Po	0.3424 W 0.178 W 0.1423 W
Co	4 μF 4 μF 31 μF
Lo	4.5 mH 19 mH 0.45 mH

- Specific condition of use:
- Precautions shall be taken to minimize the risk of non-metallic parts and painted parts of the enclosure. When the equipment is used in hazardous locations, avoid any action which generates electrostatic discharge such as rubbing with a dry cloth.

Rev.3: Dec. 26, 2019

Yokogawa Electric Corporation

Doc. No.: IFM039-A72 P.2

Model: FLEXA Series

Date: May 29, 2017

Notes:

1. No revision to this drawing without prior approval of FM.
2. Installation must be in accordance with the National Electric Code (NFPA 70), ANS/ISA-RP12.06.01 and relevant local codes.
3. FISCO Installation must be in accordance with ANSI/UL-60079-25.
4. The associated apparatus must be FM-approved.
5. The associated apparatus must be a FISCO power supply or a linear source meeting the following conditions.

$$U_o \text{ (or } V_{oc}) \leq U_i$$

$$I_o \text{ (or } I_{sc}) \leq I_i$$

$$P_o \leq P_i$$

$$C_o \text{ (or } C_a) \geq C_i + C_{cable}$$

$$L_o \text{ (or } L_a) \geq L_i + L_{cable}$$

6. Control equipment connected to the associated apparatus must not use or generate a voltage which exceeds U_m of the associated apparatus.
7. The control drawing of the associated apparatus must be followed when installing the equipment.
8. When installed in Division 1, Zone 0 or Zone 1, Sensor 1 may be a simple apparatus or an intrinsically safe apparatus meeting the conditions below.
When installed in Division 2 or Zone 2, Sensor 1 may be a simple apparatus or a nonincendive field wiring apparatus meeting the conditions below, or alternatively, it may be equipment suitable for Division 2 or Zone 2 respectively, if a suitable wiring method other than nonincendive field wiring is employed.

$$U_i \text{ (or } V_{max}) \geq U_o$$

$$I_i \text{ (or } I_{max}) \geq I_o$$

$$P_i \geq P_o$$

$$C_i \leq C_o - C_{cable}$$

$$L_i \leq L_o - L_{cable}$$

9. The control equipment must be an FM-approved FISCO power supply, FNICO power supply or an associated nonincendive field wiring apparatus meeting the conditions below. Alternatively, it may be general-purpose equipment, if a suitable wiring method other than nonincendive field wiring is employed.

$$U_o \text{ (or } V_{oc}) \leq U_i$$

$$C_o \text{ (or } C_a) \geq C_i + C_{cable}$$

$$L_o \text{ (or } L_a) \geq L_i + L_{cable}$$

10. WARNING – POTENTIAL ELECTROSTATIC CHARGING HAZARD – WHEN THE EQUIPMENT IS USED IN HAZARDOUS LOCATIONS, AVOID ANY ACTION WHICH GENERATE ELECTROSTATIC DISCHARGE SUCH AS RUBBING WITH A DRY CLOTH.
11. WARNING – IN THE CASE WHERE THE ENCLOSURE OF THE ANALYZER IS MADE OF ALUMINUM, IF IT IS MOUNTED IN ZONE 0, IT MUST BE INSTALLED SUCH THAT EVEN FRICTION SPARKS ARE EXCLUDED
12. WARNING – SUBSTITUTION OF COMPONENTS MAY IMPAIR INTRINSIC SAFETY AND SUITABILITY FOR DIVISION 2 / ZONE 2

Rev.

Doc. No.: IFM039-A72 P.3

Yokogawa Electric Corporation

(3) CSA Intrinsic safety, Nonincendive

Model: FLXA21 / FLXA202 Date: May 29, 2017
 Control drawing (FOUNDATION Fieldbus / PROFIBUS PA type)

Installation for Zone 0, 1 / Division 1

Applicable models: FLXA21-D-x-x-CD-xx-xx-F, ..., FLXA21-D-x-x-CD-xx-xx-P, ...

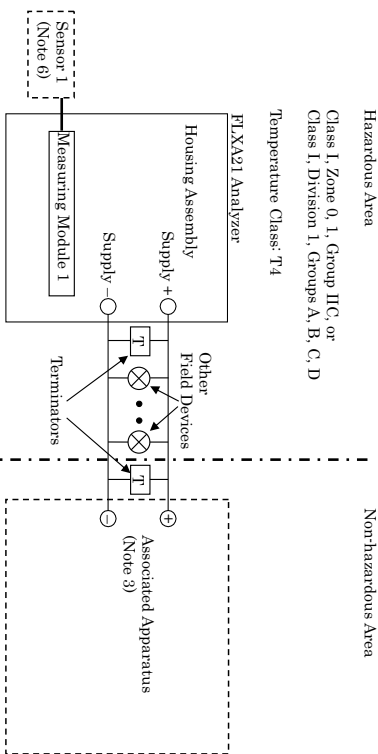

Hazardous Area
 Class I, Zone 0, 1, Group IIC, or
 Class I, Division 1, Groups A, B, C, D
 Temperature Class: T4

Non-hazardous Area

Supply +, Supply - (Note 3):
 FISCO field device
 or
 Ui: 24 V
 Ii: 250 mA
 Pi: 1.2 W
 Ci: 2.72nF
 Li: 0 mH

Measuring Module 1 (Note 6):

	Type of Measuring Module	ISC	SENCOM
Uo	pH, SG, DO	11.76 V	5.36 V
Io		11.76 V	
Io		116.5 mA	60.6 mA
Po		0.3424 W	0.178 W
Co		100 nF	100 nF
Lo		1.7 mH	8 mH

Specific condition of use
 - Electrostatic charges on the non-metallic or coated parts of the two wire analyzer shall be avoided.

Rev. Doc. No.: ICS032-A72 P.1

Yokogawa Electric Corporation

Model: FLXA21 / FLXA202 Date: May 29, 2017

Installation for Zone 2 / Division 2

Applicable models: FLXA21-D-x-x-CD-xx-xx-F, ..., FLXA21-D-x-x-CD-xx-xx-P, ...
 FLXA21-D-x-x-DD-xx-xx-F, ..., FLXA21-D-x-x-DD-xx-xx-P, ...

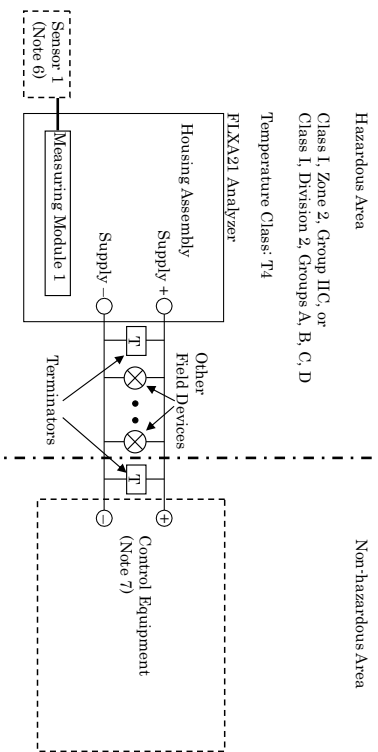

Hazardous Area
 Class I, Zone 2, Group IIC, or
 Class I, Division 2, Groups A, B, C, D
 Temperature Class: T4

Non-hazardous Area

Supply +, Supply - (Note 7):
 Ui: 24 V
 Ci: 2.72 nF
 Li: 0 mH

Measuring Module 1 (Note 6):

	Type of Measuring Module	ISC	SENCOM
Uo	pH, SG, DO	11.76 V	5.36 V
Io		11.76 V	
Io		116.5 mA	60.6 mA
Po		0.3424 W	0.178 W
Co		100 nF	100 nF
Lo		1.7 mH	8 mH

Specific condition of use
 - Electrostatic charges on the non-metallic or coated parts of the two wire analyzer shall be avoided.

Rev. Doc. No.: ICS032-A72 P.2

Yokogawa Electric Corporation

Model: FLXA21 / FLXA202

Date: May 29, 2017

Notes:

1. Installation must be in accordance with the Canadian Electric Code Part I (C22.1), ANSI/ISA-RP12.06.01 and relevant local codes.
2. FISCO installation must be in accordance with CAN/CSA-C22.2 No. 60079-25.
3. The associated apparatus must be a FISCO power supply or a linear source meeting the following conditions.

$$\begin{aligned} U_0 \text{ (or } V_{oc}) &\leq U_i \\ I_0 \text{ (or } I_{sc}) &\leq I_i \\ P_0 &\leq P_i \\ C_0 \text{ (or } C_a) &\geq C_i + C_{cable} \\ L_0 \text{ (or } L_a) &\geq L_i + L_{cable} \end{aligned}$$

4. Control equipment connected to the associated apparatus must not use or generate a voltage which exceeds U_m of the associated apparatus.
5. The control drawing of the associated apparatus must be followed when installing the equipment.
6. When installed in Zone 0 or 1, or Division 1, Sensor 1 may be a simple apparatus or an intrinsically safe apparatus meeting the conditions below.
When installed in Zone 2 or Division 2, Sensor 1 may be a simple apparatus or a non-incendive field wiring apparatus meeting the conditions below, or alternatively, it may be equipment suitable for Zone 2 or Division 2 respectively, if a suitable wiring method other than non-incendive field wiring is employed.

$$\begin{aligned} U_i \text{ (or } V_{max}) &\geq U_0 \\ I_i \text{ (or } I_{max}) &\geq I_0 \\ P_i &\geq P_0 \\ C_i &\leq C_0 - C_{cable} \\ L_i &\leq L_0 - L_{cable} \end{aligned}$$

7. The control equipment must be a FISCO power supply, FISCO power supply or an associated non-incendive field wiring apparatus meeting the conditions below.
Alternatively, it may be general-purpose equipment, if a suitable wiring method other than non-incendive field wiring is employed.

$$\begin{aligned} U_0 \text{ (or } V_{oc}) &\leq U_i \\ C_0 \text{ (or } C_a) &\geq C_i + C_{cable} \\ L_0 \text{ (or } L_a) &\geq L_i + L_{cable} \end{aligned}$$

8. WARNING – POTENTIAL ELECTROSTATIC CHARGING HAZARD
AVERTISSEMENT – DANGER POTENTIEL DE CHARGES ELECTROSTATIQUES
9. WARNING – SUBSTITUTION OF COMPONENTS MAY IMPAIR INTRINSIC SAFETY
AVERTISSEMENT – LA SUBSTITUTION DE COMPOSANTS PEUT COMPROMETTRE LA SECURITE INTRINSÈQUE.
10. WARNING – SUBSTITUTION OF COMPONENTS MAY IMPAIR SUITABILITY FOR ZONE 2 / DIVISION 2.
AVERTISSEMENT – LA SUBSTITUTION DE COMPOSANTS PEUT RENDRE CE MATÉRIEL INACCEPTABLE POUR LES EMPLACEMENTS DE ZONE 2 / DIVISION 2.

Rev.

Doc. No.: ICS032-A72 P.3

Yokogawa Electric Corporation

(4) NEPSI and KCs Intrinsic safety “ia” (Refer to App. (1) ATEX and IECEx Control Drawing)

■ Model & Suffix Codes

Model	Suffix code	Option code	Description
FLXA21	2-Wire Analyzer
Power supply	-D	Always -D
Housing	-P	Plastic
Display	-D	Anti-glare LCD
Type	-AB -AD -AG -CB -CD -CH -EG -DD	General purpose for CE, RCM General purpose for CSA General purpose for KC IS for ATEX, IECEx (Note 1) (Note 2) IS for FM, CSA (Note 1) IS for NEPSI (Note 1) IS for KCs (Note 1) NI for FM, CSA (Note 3)
1st input	-P1 -C1	pH/ORP Conductivity (SC)
2nd input	-NN	Without input
Output (Note 4)	-F	FOUNDATION Fieldbus
—	-N	Always -N
Language set (Note 5)	-LA	English and 11 languages
Country	-N	Global except Japan
—	-NN	Always -NN
Option	Mounting hardware Hood Tag plate Conduit adapter	/UM /U /PM /H6 /H7 /H8 /SCT /CB4 /CD4 /CF4	Universal mounting kit (Note 6) Pipe and wall mounting hardware Panel mounting hardware Hood, stainless steel Hood, stainless steel + urethane coating Hood, stainless steel + epoxy coating Stainless steel tag plate Conduit adapter (G1/2 x 4 pcs) Conduit adapter (1/2NPT x 4 pcs) Conduit adapter (M20 x 1.5 x 4 pcs)

Notes:

- 1: Type "-CB", "-CD", "-CH", "-EG" are intrinsic safety (IS).
- 2: Product registration is done by Yokogawa Taiwan Corporation as an importer in Taiwan.
- 3: Type "-DD" is nonincendive (NI).
- 4: The FLXA21 has another output type of "4-20 mA + HART" (suffix code: -A). Refer to GS 12A01A02-01E.
- 5: These languages are message languages on the analyzer's display.
One analyzer has English and 11 languages.
All languages are as follows; English, Chinese, Czech, French, German, Italian, Japanese, Korean, Polish, Portuguese, Russian and Spanish.
- 6: The universal mounting kit contains the pipe and wall mounting hardware (/U) and the panel mounting hardware (/PM).

■ Dimensions and Mounting

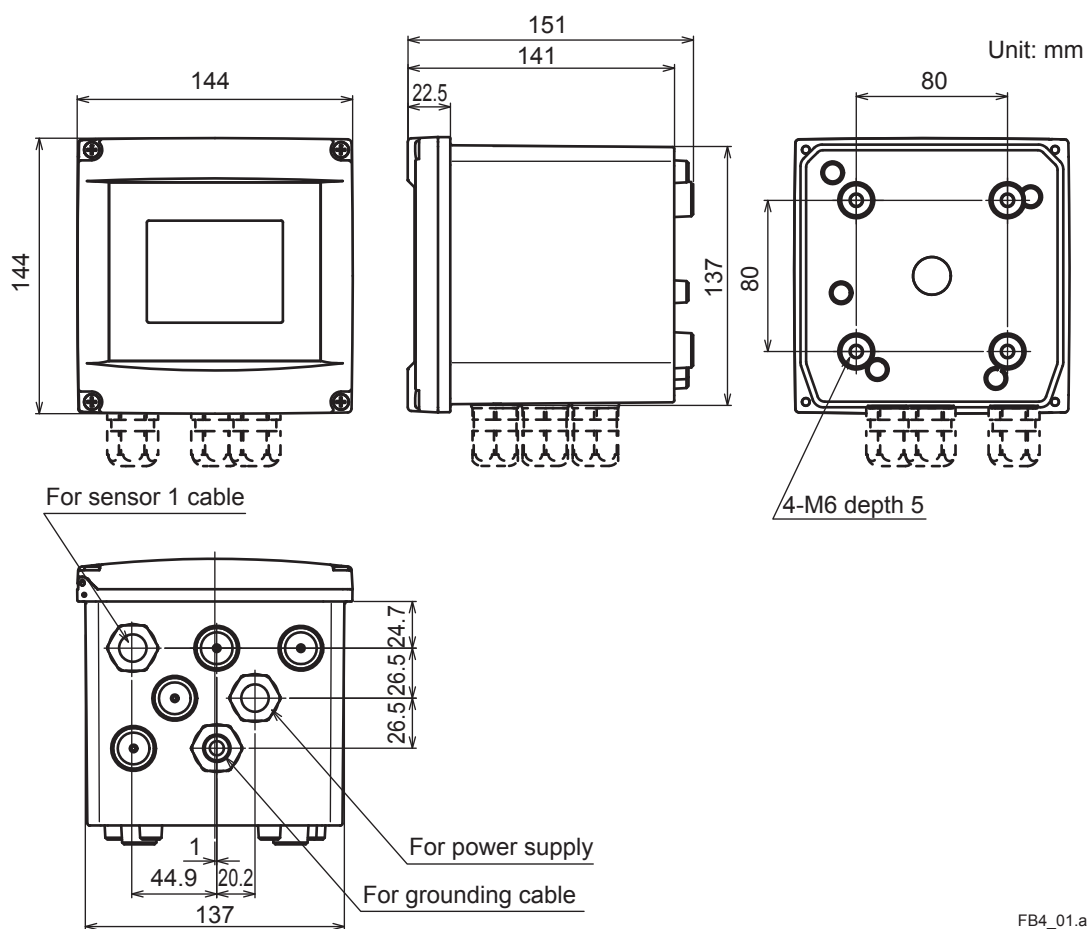

FB4_01.ai

Conduit Adapter (Option code: □/CB4, □/CD4, □/CF4)

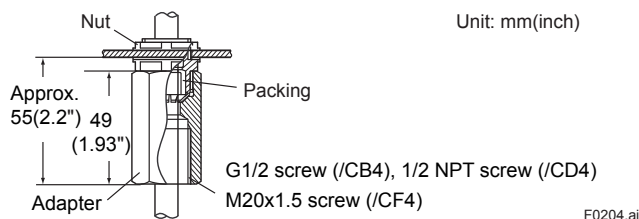

F0204.ai

(Note) The universal mounting kit (/UM) contains the pipe and wall mounting hardware (/U) and the panel mounting hardware (/PM).

Panel mounting hardware (Option code: □/PM, □/UM)

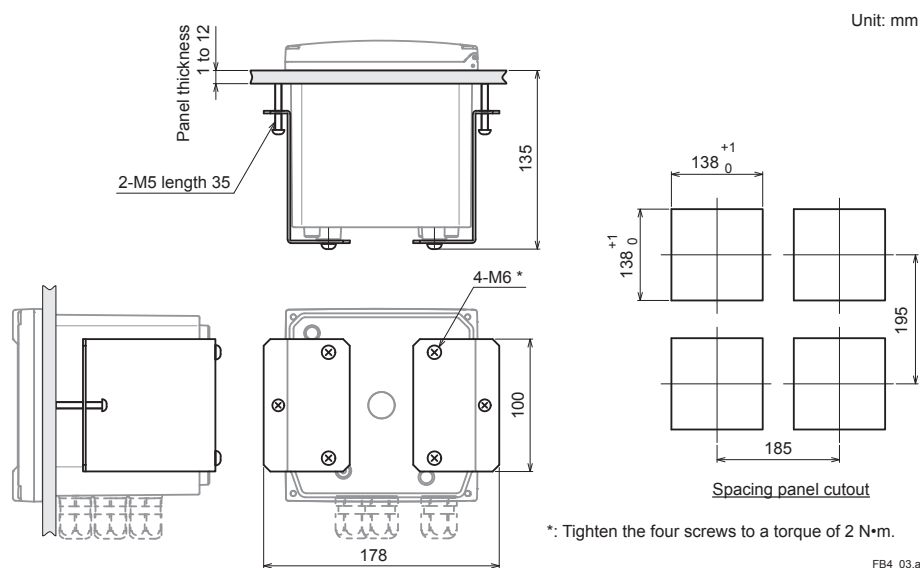

Wall mounting hardware (Option code: □/U, □/UM)

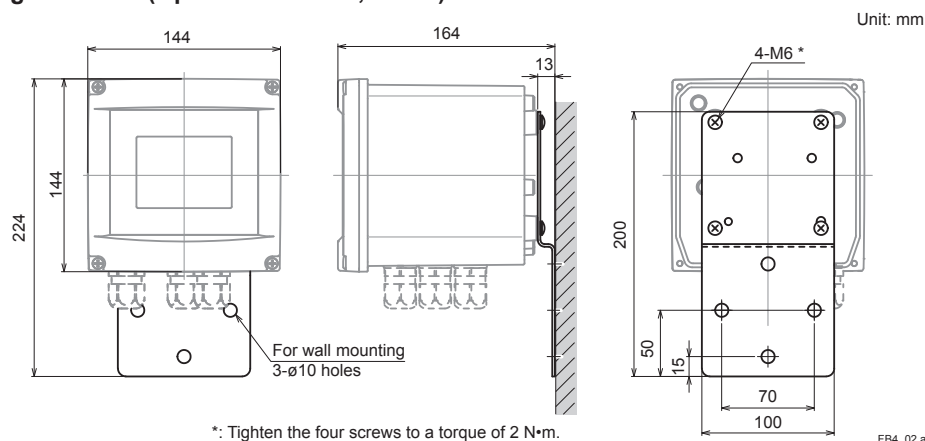

Note: The wall on which the analyzer is mounted should be strong enough to bear the weight of more than 8 kg.

Pipe mounting hardware (Option code: □/U, □/UM)

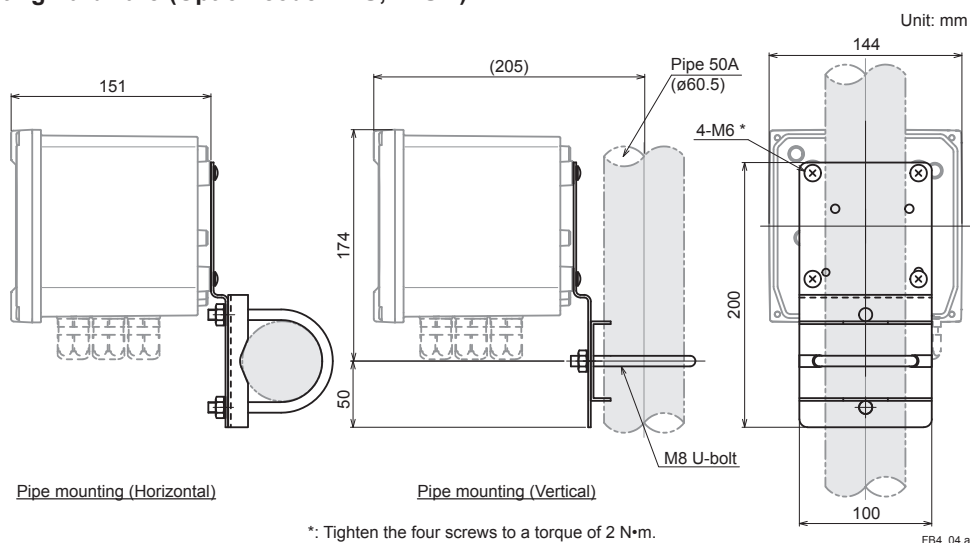

Stainless steel hood (Option code: □/H6, □/H7, □/H8)

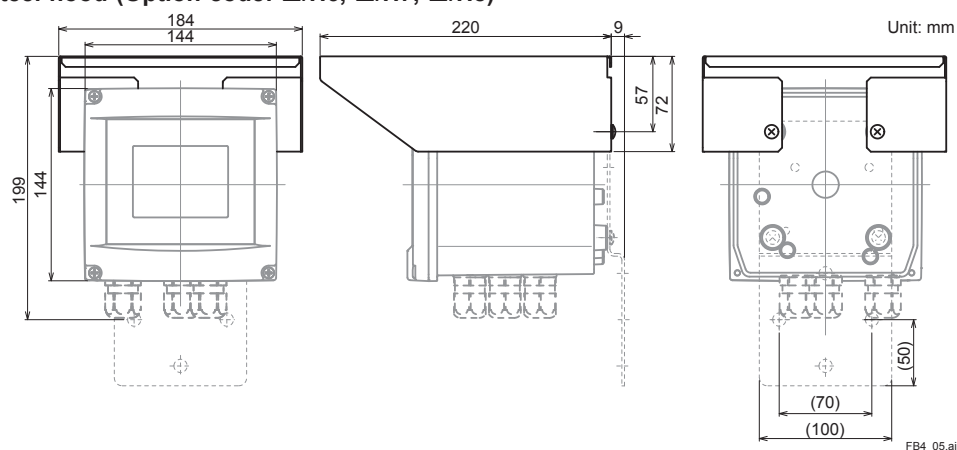

■ Wiring Diagrams

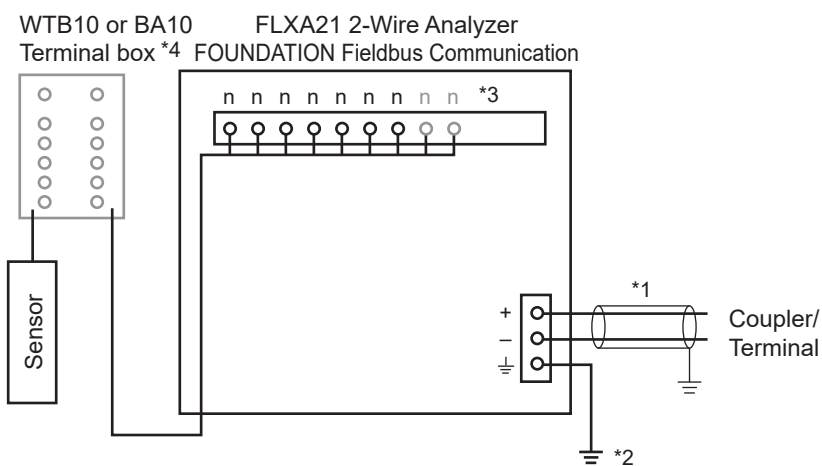

- *1: Use a 2-wire shielded cable with an outside diameter of 6 to 12 mm.
- *2: Connect the analyzer to gland. (Class D ground: 100 ohm or less)
Connect the grounding cable to the \perp terminal of the power module inside.
Use a cable with an outside diameter of 3.4 to 7 mm for the grounding line of the plastic housing.
The minimum cross sectional area of the protective grounding cable should be 0.75 mm².
- *3: Terminal numbers for each sensor module are shown below.
- *4: The terminal box may be necessary depending on the sensor cable length and the distance between the analyzer and the sensor.

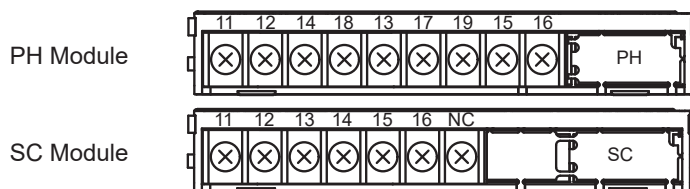

■ Inquiry Specifications Sheet for FLXA21 2-Wire Analyzer (FOUNDATION Fieldbus Communication)

Make inquiries by placing checkmarks (✓) in the pertinent boxes and filling in the blanks.

1. General Information

Company name _____
 Contact Person; _____ Department; _____
 Plant name; _____
 Measurement location; _____
 Purpose of use; Indication, Recording, Alarm, Control

2. Measurement Conditions

(1) Process temperature; _____ to _____ Normally _____ [°C]
 (2) Process pressure; _____ to _____ Normally _____ [kPa]
 (3) Flow rate; _____ to _____ Normally _____ [l/min]
 (4) Flow speed; _____ to _____ Normally _____ [m/s]
 (5) Slurry or contaminants; No, Yes
 (6) Name of process fluid; _____
 (7) Components of process fluid; _____
 (8) Others;

3. Installation Site

(1) Ambient temperature; _____ to _____ [°C]
 (2) Location; Outdoors, Indoors
 (3) Others;

4. Requirements

1st Input; pH/ORP Conductivity (SC)
 2nd Input; Without

4.1 pH/ORP

(1) Measuring range; pH 0 to 14 ORP _____ to _____ mV _____
 (2) System configuration selection; Electrode, Holder, pH Converter, Cleaning system, Terminal box,
 Accessories
 (3) Electrode cable length; 3m, 5m, 7m, 10m, 15m, 20m, _____m
 (4) Electrode operating pressure; 10 kPa or less, More than 10 kPa
 (5) Type of holder; Guide pipe, Submersion, Flow-through, Suspension, Angled floating ball, Vertical floating ball
 (6) Cleaning method; No cleaning, Ultrasonic cleaning, Jet cleaning, Brush cleaning
 (7) Sample temperature; -5 to 105°C, -5 to 100°C, -5 to 80°C
 (8) Others;

4.2 Conductivity

(1) Measuring range; _____
 (2) Detector/sensor; SC4AJ Two electrode system (0.02 cm⁻¹) Two electrode system (0.1 cm⁻¹)
 SC8SG Two electrode system (0.01 cm⁻¹) Two electrode system (10 cm⁻¹),
 Four electrode system (10 cm⁻¹)
 SC210G Two electrode system (0.05 cm⁻¹) Two electrode system (5 cm⁻¹)
 (3) Detector/sensor mounting method;
 SC4AJ Adapter mounting, Welding socket, Welding clamp
 SC8SG Screw-in, Flow-through
 SC210G Screw-in, Flange, Flow-through, Screw-in with gate valve
 (4) Electrode cable length; SC4AJ 3m, 5m, 10m, 20m
 SC8SG 5.5m, 10m, 20m
 SC210G 3m, 5m, 10m, 15m, 20m
 (5) Others;