



Sievers M500 operation and maintenance manual

1.00 firmware or later

Sievers M500
Total Organic Carbon (TOC) Analyzer



Printed in the USA © 2020

**6060 Spine Road
Boulder, CO 80301 USA
www.sieversinstruments.com**

***For technical support, contact Technical Support or your local service provider.
In the Americas, contact Technical Support at +1 888 245 2595.
In Europe, the Middle East, and Africa, contact
Technical Support at +44 161 864 6800.***

***To order standards or replacement parts, contact Customer Care
at +1 800 255 6964 or your local service provider.***

***For a copy of the Declaration of Conformity and ISO 9001 Registration:
Visit our website [Customer Support > Sievers Analyzers & Instruments >
Sievers Accreditations & Certificates > ISO Certifications and Accreditations
(or Declarations of Conformity)].***

Electronic versions of the Analyzer's *Operation and Maintenance Manual*
and the *M500 Qualification Package — IQ/OQ Volume* are available from our website: [Customer Support
> Sievers Analyzers & Instruments > Manuals and Validation Support Packages (VSPs) > M500].



IDENTIFICATION RECORDS

Analyzer serial number:

(This is located on the side of the Analyzer.)

Date of receipt and installation of Analyzer:

(This is the warranty start date.)

Default Administrative User ID:

ADMIN

Default Administrative Password:

SIEVERS

Table of Contents

<i>Identification Records</i>	3
List of Tables	12
List of Figures	13
<i>Document Revision History</i>	14
<i>Trademarks and Patents</i>	14
<i>Confidentiality</i>	14
<i>Declaration of Conformity</i>	14
<i>Standard Limited Warranty</i>	15
<i>Warnings</i>	19
English	19
Español	23
Français	27
Deutsch	31
Italiano	35
日本語	39
한국어	42
Português	45
中文	49
Chapter 1: Introduction	53
Chapter 2: System Description	55
System Specifications	55
System Overview	56
Sample Flow Path	57
Additional System Components	59
Microprocessor Controller and Electronics	59
<i>Data Outputs</i>	59
Chapter 3: Installation	61
Overview	61
STEP 1: UNPACK AND INSPECT THE ANALYZER	62
Packing List	62
Additional Installation Equipment	63

STEP 2: COMPLETE THE IDENTIFICATION RECORDS	64
STEP 3: SELECT A LOCATION FOR THE ANALYZER	64
STEP 4: INSTALL I/O CONTROL WIRING (OPTIONAL)	64
Installing I/O Wiring	65
Working with Alarm Outputs (J1)	68
Working with 4-20 mA Analog (J4) Outputs	69
Working with Binary Inputs (Remote Start/Stop) (J2)	70
STEP 5: INSTALL POWER	72
Installing the AC Conduit	72
STEP 6: CONNECT THE SAMPLE INLET AND OUTLET PORTS	75
Configuring the sample inlet and outlet ports	76
STEP 7: INSTALL THE DI WATER SYSTEM	77
Installing the Calibration resistor	77
Using the Instrument Startup Wizard	77
STEP 8: INSTALL ETHERNET AND EXTERNAL DEVICES	86
Installing a USB Connection for Data Transfer (Optional)	87
Installing a Serial Connection (Optional)	88
Installing an Ethernet Connection (Optional)	89
STEP 9: CONFIGURE BASIC ANALYZER SETTINGS	89
Enabling Analyzer Security (Optional)	89
Enabling Password Protection (Optional)	90
Activating DataGuard (Optional)	91
Configuring Local Settings	94
Setting the Measurement Mode	96
Configuring an Ethernet Connection	100
Enabling a PDF Printer	101
Setting up a Wireless Connection	103
Saving System Constants	104
Configuring the Data I/O	107
Chapter 4: Basic Analyzer Operation	113
Overview	113
Powering On and Off the Analyzer	113
<i>Recommended Operational State</i>	116
The iOS Systems	116
Using the Standard iOS System	117

Using the Super iOS System	118
<i>Vial Set Cartridges</i>	118
Using the Sample Inlet Block	119
<i>Steam Exposure</i>	119
The Analyzer Screens	120
Navigating the Analyzer Screens	120
<i>The Standard Toolbar</i>	120
Printing and Exporting from the Analyzer Screens.	123
The Home Screen.	126
Setting the Measurement Mode	128
Running Online Analysis	131
Running a Grab Sample.	132
The Protocols Screen	136
The Settings Screen	137
Settings Screen — System Setup Tab	137
Configuring Local Settings	137
Configuring Result Preferences	140
Setting Trend Graph Display Options.	141
Specifying the Pharmacopoeia.	141
Working with Pharmacopoeia Monographs	143
<i>Pass/Fail Reporting</i>	143
<i>Pharmacopoeia Options</i>	144
Configuring Export Preferences	145
Settings Screen — Instrument Settings Tab.	147
Viewing System Constants.	147
Saving System Constants	148
Printing and Exporting or System Constants	148
Settings Screen — Analyzer Settings Panel.	149
Reviewing Analyzer Settings	150
Saving Analyzer Settings	150
Importing Analyzer Settings	152
Setting a User TOC Offset	153
Setting Conductivity Temperature Compensation	153
Activating Options	155
Upgrading Firmware.	156
Settings Screen — Hardware Tab	159
Configuring Alarm Outputs	160
Configuring 4-20 mA Analog Outputs.	162
Configuring Binary Input (Start/Stop)	163
Configuring an Ethernet Connection	165
Configuring the Flow Sensor	166
Enabling the DI Reservoir Level Sensor	168

Enabling the UV Lamp	169
Enabling a PDF Printer	170
Configuring a WiFi Connection (Optional)	172
Settings Screen — Consumables Tab	173
Entering and Reviewing Consumables Status	173
Settings Screen — Errors Tab	174
Settings Screen — Backup/Restore Tab	175
Backing Up the Database	175
Scheduling Automatic Database Backups	177
Archiving the Database	179
Restoring a Backup	183
Restoring System Constants	184
The Data Screen.	184
Reviewing Data History	185
The DataGuard Screen.	189
The Help Screen.	190
Chapter 5: Password Protection and DataGuard	191
Overview	191
Password Protection	191
Using Password Protection	191
Enabling Password Protection	191
DataGuard	194
Enabling DataGuard	194
Logging into DataGuard	194
Managing User Accounts	195
Creating and Revising Access Levels	200
Configuring Login Settings	205
Changing User Passwords	207
Replacing a Forgotten Password	209
Working with Audit Trails	210
Logging Out of DataGuard	212
Chapter 6: Calibration and System Protocols	213
Overview	213
Performing Pharmacopoeia Tests	214
Programming the TOC Autozero	214
Programming the TC/IC Conductivity Autozero	216
Required Calibration Supplies	217
Calibration Preparations.	222

Saving System Settings	222
Performing Annual Maintenance Tasks	226
Handling Standards	226
Disable Automatic Backup	227
After Calibration	227
Super iOS Drain/Rinse	228
Using Individual Vials in the Super iOS	229
TOC Single Point Calibration	231
TOC Multi-point Calibration Protocol	236
Sample Conductivity Single Point Calibration Protocol	243
Sample Conductivity Multi-point Calibration Protocol	249
TC/IC Conductivity Autozero Protocol	257
TOC Autozero Calibration Protocol	260
Sample Conductivity Autozero Protocol	263
System Suitability Protocol	266
Accuracy & Precision Verification Protocol	270
Cell Calibration Verification Protocol	274
Sample Conductivity Verification Protocol	280
Resistance Verification Protocol	285
TOC Linearity Protocol	288
<i>Two LOD/LOQ Methodologies</i>	288
Robustness Verification Protocol	296
Specificity Verification Protocol	300
SDBS Suitability Protocol	305
SDBS Suitability With Conductivity Protocol	309
Sample Conductivity Linearity Protocol	315
Online TOC LOD/LOQ Protocol (Optional)	326
Reviewing Calibration and Verification History	329
TOC Single Point Calibration Worksheet	331
TOC Multi-Point Calibration Worksheet	333
Sample Conductivity Single Point Calibration Worksheet	335
Sample Conductivity Multi-point Calibration Worksheet	337
TC/IC Conductivity Autozero Worksheet	339
TOC Autozero Worksheet	341
Sample Conductivity Autozero Worksheet	343
Accuracy & Precision Verification Worksheet	345
Cell Calibration Verification Worksheet	347
Resistance Verification Worksheet	349
System Suitability Worksheet	351
TOC Linearity Worksheet	353

Specificity Protocol Worksheet	355
Robustness Protocol Worksheet	357
SDBS Suitability Worksheet	359
SDBS Suitability with Conductivity Worksheet	361
Sample Conductivity Linearity Worksheet	363
Online TOC LOD/LOQ Protocol Worksheet (OPTIONAL)	365
Chapter 7: Troubleshooting	367
Overview	367
STEP 1: VISUAL INSPECTION	367
Inspecting Externally	367
Inspecting Internally	368
STEP 2: REVIEW WARNINGS AND ERRORS	370
Reviewing Errors and Warnings	370
Warnings and Error Messages	373
<i>800—The sample conductivity analog reading is out of range.</i>	373
<i>3100—Unexpected DI Loop level.</i>	375
<i>3102—DI flow on IC/TC channel not detected.</i>	376
STEP 3: REVIEW SOLUTIONS FOR BASIC PROBLEMS	376
<i>The Analyzer Will Not Power On</i>	376
<i>Checking the Sample Pump.</i>	376
<i>No Sample Flow Through the Analyzer</i>	377
<i>Confirm Flow of Water through the Measurement Module, DI Side.</i>	378
Negative, High, or Erratic Measurements	379
<i>TC/IC Conductivity Autozero</i>	379
<i>Sample Conductivity Cell Calibration</i>	379
<i>Sample Conductivity Autozero</i>	379
<i>TOC Autozero</i>	380
<i>TOC Offset.</i>	380
<i>Problems Changing the Program Language.</i>	380
<i>Problems with Vial Set Cartridges</i>	382
<i>Problems with The DI Water Pump</i>	382
Using the Diagnostics Menu	383
System Tests	384
Alarms	384
Analog Outputs	386
Modbus	387

Printer	389
Sample Flow Rate	389
Super iOS	389
Testing the Super iOS	390
IC Power Relay	394
Internet Connection	394
USB Serial Loopback	395
Serial Loopback	396
WiFi	396
Export Diagnostics	397
Service Diagnostics	397
Level 1 Diagnostics	398
STEP 4: CONTACT TECHNICAL SUPPORT	399
STEP 5: RETURN THE ANALYZER TO SUEZ	399
To prepare Analyzer for shipping	400
<i>Draining the Sample Side</i>	400
<i>Draining the DI Loop</i>	404
Chapter 8: Maintenance	407
Replacing Consumables and Maintenance Items	407
Verifying the DI Water Level	408
Replacing the UV Lamp	410
Replacing the Sample Pump Heads	413
Replacing the Resin Cartridge	415
Replacing the In-Line Filter Element	417
Replacing the Fan Filter	419
Entering New Consumables Installation Dates	419
Cleaning the Analyzer	420
Appendix A: Analyzer Dimensions	423
Analyzer Dimensions	423
Analyzer Configured with Standard iOS	424
Analyzer Configured with Super iOS	427
Analyzer Configured with Sample Inlet Block	430
Appendix B: Streaming Data	433
Determining Your Communications Port Number	434
Appendix C: Warning and Error Descriptions	435

Appendix D: DI Water Installation Details.	443
Additional DI Water Installation Details	443
Installing the resin cartridge	443
Rinsing the Analyzer	448
Appendix E: Modbus with the Analyzer	451
The Ethernet Connection and Modbus.	451
Enabling Modbus	451
Testing Modbus for the Analyzer	452
The Modbus Register Table	452
Appendix F: Temperature Compensation.	459
Sample Conductivity Temperature Compensation	459
<i>Temperature Compensation.</i>	<i>460</i>
<i>Reference Temperature</i>	<i>460</i>
<i>Reference Type Algorithm — Linear Compensation</i>	<i>461</i>
<i>Reference Type Algorithm — Nonlinear Compensation</i>	<i>462</i>
<i>Other Compensation Considerations</i>	<i>462</i>
<i>Verification Methodology and Expectations</i>	<i>463</i>
Index.	465

List of Tables

Table 1	Alarm Relay Outputs (J1)	68
Table 2	4-20 mA Analog Outputs (J4)	69
Table 3	Isolated State Inputs (J2)	70
Table 4	Isolated State Inputs (J2)	88
Table 5	The Analyzer's Standard Toolbar	121
Table 6	Record of User IDs	199
Table 7	Roles and Role Abilities	202
Table 8	Audit Trail Output Format	210
Table 9	Standards Required for TOC Single-Point Calibration	218
Table 10	Standards Required for TOC Multi-Point Calibration	218
Table 11	Standards Required for Sample Conductivity Single-Point Calibration	218
Table 12	Standards Required for Sample Conductivity Multi-Point Calibration	218
Table 13	Standards Required for System Suitability Verification	219
Table 14	Standards Required for Accuracy & Precision Verification	219
Table 15	Standards Required for Cell Calibration Verification	219
Table 16	Standards Required for Sample Conductivity Verification	219
Table 17	Standards Required for TOC Linearity Verification	220
Table 18	Standards Required for Robustness Validation	220
Table 19	Standards Required for Specificity Validation	220
Table 20	Standards Required for SDBS Suitability	221
Table 21	Standards Required for Sample Conductivity Linearity Validation	221
Table 22	Replacement Schedule for Consumables	408
Table 16	Sievers M500 TOC Analyzer 3-Year Maintenance Worksheet	421
Table 17	Modbus Register Table	453
Table 18	Common Linear Constants	461

List of Figures

Figure 1	Analyzer Schematic (Shown with Standard iOS)	57
Figure 2	Interior Overview of the Analyzer.	62
Figure 3	Alarm Relay Output Detail	69
Figure 4	Typical 4-20 mA Circuit Applications	70
Figure 5	Isolated State Input Circuit Detail	71
Figure 6	Instrument-Powered Isolated State Input Circuit Application.	71
Figure 7	Externally-Powered Isolated State Input Circuit Application	72
Figure 8	Input and Output Connections	87
Figure 9	Asynchronous Serial Port (RS-232).	88
Figure 10	Home screen when Password Protection or DataGuard is not enabled .	114
Figure 11	Home screen when Password Protection or DataGuard is enabled	115
Figure 12	The Standard iOS System	117
Figure 13	The Super iOS System	118
Figure 14	The Sample Inlet Block	119
Figure 15	Standard Toolbar	121
Figure 16	The Home Screen	126
Figure 17	Interior Overview of the Analyzer.	408
Figure 18	Analyzer Dimensions, with Standard iOS System	424
Figure 19	Right-Side Analyzer Dimensions, with Standard iOS System	425
Figure 20	Left-Side Analyzer Dimensions, with Standard iOS System	426
Figure 21	Analyzer Dimensions, with Super iOS System	427
Figure 22	Right-Side Analyzer Dimensions, with Super iOS System	428
Figure 23	Left-Side Analyzer Dimensions, with Super iOS System.	429
Figure 24	Analyzer Dimensions, with Sample Inlet Block	430
Figure 25	Right-Side Analyzer Dimensions, with Sample Inlet Block	431
Figure 26	Left-Side Analyzer Dimensions with Sample Inlet Block	432
Figure 27	Linearity of Sievers M500 TOC Analyzer Conductivity Measurement . . .	463

DOCUMENT REVISION HISTORY

Document Version	Firmware Version/Enhancement	Date
DLM 78500-01 EN Rev. A	1.00	December 2020

TRADEMARKS AND PATENTS

Sievers,[®] DataGuard,[®] and Super iOS[®] are trademarks of SUEZ and may be registered in one or more countries.

Centronics[®] is a trademark of Centronics Data Computer Corporation; Citizen[®] is a registered trademark of CBM, Inc; Epson[®] is a registered trademark of Seiko Epson, Inc.; IBM[®] is a registered trademark of International Business Machines Corporation; John Guest[®] is a registered trademark of John Guest International Limited; Swagelok[®] is a registered trademark of the Swagelok Company; Teflon[®] is a registered trademark of E.I. du Pont de Nemours. Windows[®] and Excel[®] are registered trademarks of the Microsoft Corporation.

The Analyzer described in this manual is covered by one or more patents issued to and owned or pending by SUEZ, including the following:

- US 6723565 and any of its non-US counterparts
- US 8101417 and any of its non-US counterparts
- US 8003048 and any of its non-US counterparts
- US 9116099 and any of its non-US counterparts
- US 9074967 and any of its non-US counterparts
- and other patents pending

CONFIDENTIALITY

The information contained in this manual may be confidential and proprietary and is the property of SUEZ. Information disclosed herein shall not be used to manufacture, construct, or otherwise reproduce the goods disclosed herein. The information disclosed herein shall not be disclosed to others or made public in any manner without the express written consent of SUEZ.

DECLARATION OF CONFORMITY

A copy of the Declaration of Conformity for this product is available on our website.

STANDARD LIMITED WARRANTY

SUEZ warrants its Sievers® products for defects in materials and workmanship. SUEZ will, at its option, repair or replace instrument components that prove to be defective with new or re-manufactured components. The warranty set forth is exclusive and no other warranty, whether written or oral, is expressed or implied.

WARRANTY TERM

The SUEZ warranty term is thirteen (13) months ex-works, or twelve (12) months from installation or start up by SUEZ certified service personnel. In no event shall the standard limited warranty coverage extend beyond thirteen (13) months from original shipment date.

WARRANTY SERVICE

Warranty Service is provided to customers through telephone support, Monday - Friday, from 8:00 a.m. to 5:00 p.m. (Mountain Time), excluding all company and legal holidays. Telephone support is provided for troubleshooting and determination of parts to be shipped from SUEZ to the customer in order to return the product to operation. If telephone support is not effective, the product may be returned to SUEZ for repair or replacement. In some instances, suitable instruments may be available for short duration loan or lease.

SUEZ warrants that any labor services provided shall conform to the reasonable standards of technical competency and performance effective at the time of delivery. All service interventions are to be reviewed and authorized as correct and complete at the completion of the service by a customer representative, or designate. SUEZ warrants these services for 30 days after the authorization and will correct any qualifying deficiency in labor provided that the labor service deficiency is exactly related to the originating event. No other remedy, other than the provision of labor services, may be applicable.

Repair components (parts and materials), but not consumables, provided in the course of a repair, or purchased individually, are warranted for 90 days ex-works for materials and workmanship. In no event will the incorporation of a warranted repair component into an instrument extend the whole instrument's warranty beyond its original term.

Consumables (e.g., dilution standards, verification solutions, and UV lamps, etc.) are warranted to the extent of their stated shelf life, provided these items are maintained within the stated environmental limitations. Warranty claims for consumables and verification standards are limited to the replacement of the defective items, prorated from the time of claim to the expiration of shelf life.

SHIPPING

A Repair Authorization Number (RA) must be obtained from the Technical Support Group before any product can be returned to the factory. SUEZ will pay freight charges, exclusive of any taxes and duties, for replacement or repaired products shipped to the customer site. Customers shall pay freight charges, including all taxes and duties, for all products returning

to SUEZ. Any product returned to the factory without an RA number will be returned to the customer.

LIMITATION OF REMEDIES AND LIABILITY

The foregoing warranty shall not apply to defects resulting from improper or inadequate installation, maintenance, adjustment, calibration, or operation by customer. Installation, maintenance, adjustment, calibration, or operation must be performed in accordance with instructions stated in the Operation and Maintenance Manual. Usage of non-recommended maintenance materials may void a warranty claim.

The remedies provided herein are the customer's sole and exclusive remedies. In no event shall SUEZ be liable for direct, indirect, special, incidental or consequential damages (including loss of profits) whether based on contract, tort, or any other legal theory. The Operation and Maintenance Manual is believed to be accurate at the time of publication and no responsibility is taken for any errors that may be present. In no event shall SUEZ be liable for incidental or consequential damages in connection with or arising from the use of the manual and its accompanying related materials. Warranty is valid only for the original purchaser. This Limited Warranty is not transferable from the original purchaser to any other party without the express written consent from SUEZ. SUEZ specifically disclaims the implied warranties of merchantability and fitness for a particular purpose.

LIMITACIÓN DE REMEDIOS Y RESPONSABILIDAD

La garantía anterior no se aplicará a los defectos que resulten de la realización incorrecta o inadecuada de la instalación, el mantenimiento, el ajuste, la calibración o el manejo por parte del cliente. La instalación, el mantenimiento, el ajuste, la calibración o el manejo deberán llevarse a cabo de acuerdo con las instrucciones indicadas en el manual de funcionamiento y mantenimiento. El uso de materiales de mantenimiento que no sean los recomendados puede anular una reclamación de garantía.

Los remedios que aquí se indican serán los únicos los remedios para el cliente. En ningún caso SUEZ será responsable de daños directos, indirectos, especiales, incidentales o consecuentes (incluida la pérdida de beneficios) ya sean contractuales, extracontractuales o basado en cualquier otra teoría legal. Se considera que el manual de funcionamiento y mantenimiento es exacto en el momento de su publicación y no se acepta ninguna responsabilidad por los errores que pueda contener. En ningún caso será SUEZ responsable de los daños incidentales o consecuentes que resulten o estén relacionados con el uso del manual y los materiales que lo acompañan. La garantía es únicamente válida para el comprador original. El comprador original no puede transferir esta garantía limitada a ninguna otra parte sin el consentimiento expreso por escrito de SUEZ. SUEZ renuncia específicamente a las garantías implícitas de comercialización e idoneidad para un determinado propósito.

LIMITES DE CORRECTION ET DE FIABILITÉ

La garantie susdite ne s'applique pas aux défauts résultants d'une installation, d'une maintenance, d'un réglage, d'un calibrage ou d'un fonctionnement inapproprié, opéré par l'utilisateur. L'installation, la maintenance, le réglage, le calibrage ou le fonctionnement doit être réalisé conformément aux instructions du manuel de l'utilisateur et de maintenance. La mise en œuvre de procédures de maintenance non recommandées peut annuler toute disposition de garantie.

Les procédures de correction indiquées dans le présent document sont les seuls remèdes du client. Le groupe SUEZ ne saurait en aucun cas être tenu pour responsable de tout préjudice direct, indirect ou spécial de quelque nature que ce soit (y compris, les pertes de bénéfiques), qu'il soit fondé sur un contrat, sur un acte dommageable ou sur une autre théorie légale. Le manuel de l'opérateur et de maintenance est aussi précis que possible au moment de la publication et la responsabilité du groupe ne saurait être engagée pour les éventuelles erreurs qu'il pourrait contenir. Le groupe SUEZ ne saurait en aucun cas être tenu pour responsable des préjudices accidentels ou de quelque nature que ce soit, dus à l'utilisation du manuel ou de la documentation connexe. La garantie ne s'applique qu'à l'acquéreur d'origine. La garantie limitée ne peut être transférée par l'acquéreur d'origine à une autre partie sans l'autorisation expresse écrite du groupe SUEZ. SUEZ exclut tout particulièrement les garanties implicites de commercialisation et d'adaptabilité dans un but spécifique.

BESCHRÄNKTE ANSPRÜCHE UND HAFTUNG

Die vorangehende Garantie gilt nicht für Schäden, die aus unsachgemäßer oder unzureichender Installation, Wartung, Anpassung, Kalibrierung oder Betrieb durch den Kunden resultieren. Installation, Wartung, Anpassung, Kalibrierung oder Betrieb müssen gemäß den Anweisungen in der Bedienungsanleitung durchgeführt werden. Durch die Verwendung von nicht empfohlenen Wartungsmaterialien kann der Garantieanspruch erlöschen.

Die hier erwähnten Ansprüche beziehen sich auf die einzigen und ausschließlichen Ansprüche des Kunden. SUEZ ist unter keinen Umständen verantwortlich für direkte, indirekte, besondere, zufällig entstandene oder Folgeschäden (einschließlich Verlust von Einkünften), die auf Vertrag, unerlaubten Handlungen oder andere Rechtstheorien basieren. Die Bedienungsanleitung ist zur Zeit der Veröffentlichung nach bestem Wissen korrekt, und es wird keine Verantwortung für mögliche vorhandene Fehler übernommen. SUEZ ist unter keinen Umständen haftbar für zufällige oder Folgeschäden, die in Verbindung mit oder durch die Verwendung der Bedienungsanleitung und begleitender Materialien entstehen. Die Garantie gilt nur für den ursprünglichen Käufer. Die beschränkte Garantie lässt sich nicht ohne ausdrückliche schriftliche Genehmigung von SUEZ vom ursprünglichen Käufer auf eine andere Person übertragen. SUEZ schließt besonders die konkludente Garantie der Handelsüblichkeit und Eignung für einen bestimmten Zweck aus.

LIMITAZIONE DI RIMEDI E RESPONSABILITÀ

La precedente garanzia non è valida per difetti risultanti da installazione, manutenzione, regolazione, taratura o utilizzo improprio o inadeguato da parte dell'utente. L'installazione, la

manutenzione, la regolazione, la taratura o l'utilizzo deve essere conforme alle istruzioni indicate nel manuale d'uso e manutenzione. L'utilizzo di materiali di manutenzione diversi da quelli consigliati rende nullo un reclamo in garanzia.

Gli unici rimedi spettanti all'utente sono quelli qui inclusi. In nessun caso SUEZ sarà responsabile per danni diretti, indiretti, speciali, accidentali o consequenziali (inclusa la perdita di profitti) risultanti dall'applicazione del contratto, atto illecito o altra teoria legale. Il manuale d'uso e manutenzione è accurato al momento della pubblicazione e l'azienda non si assume alcuna responsabilità per la presenza di eventuali errori. In nessun caso SUEZ sarà responsabile per danni accidentali o consequenziali correlati o derivanti dall'utilizzo del manuale e di altro materiale di supporto correlato. La garanzia è valida solo per l'acquirente originale. La presente garanzia limitata non è trasferibile dall'acquirente originale a terzi senza l'esplicito consenso scritto da parte di SUEZ. SUEZ declina espressamente le garanzie implicite di commerciabilità e idoneità a un particolare scopo.

限定責任および救済

前述の保証は、お客様による不適切または不十分な取り付け、保守、調整、校正、あるいは操作によって生じた不具合には適用されないものとします。取り付け、保守、調整、校正、または操作は、『Operation and Maintenance Manual (操作取扱説明書)』に記載されている指示に従って行う必要があります。推奨外の保守資材を使用すると、保証請求が無効になる場合があります。

ここで提供される救済は、お客様の唯一の排他的救済となります。SUEZ は、いかなる場合においても、直接的、間接的、特別的、付随的、または派生的損害（利益の逸失を含む）に対し、それが契約、不法行為、またはその他の法的理論に基づくものであるかどうかにかかわらず、一切責任を負いません。『Operation and Maintenance Manual (操作取扱説明書)』は、出版された時点で正確であるものと考えられており、万が一発生した誤りに対する責任は一切負いません。SUEZ は、いかなる場合においても、マニュアルまたはそれに付属の関連資料の使用に関連して、またはその使用が原因で発生した付随的または派生的損害にも一切責任を負いません。保証は最初の購入者に対してのみ有効です。本限定保証を、SUEZ の書面による同意なしに、最初の購入者から第三者に譲渡することはできません。SUEZ は、商品性および特定の目的に対する適合性の黙示の保証を一切拒否します。









赔偿与责任限制

上述保证不适用于因客户不正确或不恰当的安装、维护、调整、校准或操作导致的故障。安装、维护、调整、校准或操作必须遵循操作与维护手册中的说明进行。使用非推荐的维护材料可能会导致保证失效。

这里提供的赔偿为客户的唯一和独占赔偿。在任何情况下，SUEZ 不对任何直接的、间接的、特殊的、偶发的或连带发生的损失（包括利润损失）负责，无论这些损害是依据何种合同责任理论、侵权行为责任理论或其它法律理论进行推断的。操作与维护手册在出版时被认为是准确的，SUEZ 不对其中可能存在的任何错误负责。在任何情况下，SUEZ 均不对因使用该手册（或与其使用有关）或相关材料导致的偶发或连带发生的损失负责。保证仅对原购买者有效。未经 SUEZ 明确书面同意，此有限保证不可由原购买者转让给任何其他方。SUEZ 特此声明不提供任何关于特殊用途的适销性和适用性的暗示担保。

WARNINGS

ENGLISH

Warnings	
	This symbol on the instrument indicates that the user should refer to the manual for operating instructions.
	The iOS System and vial ports contain sharp needles designed to pierce the septa of sample vials. Do not put fingers or inappropriate materials into the iOS System or vial port.
	Water in the iOS system may be hot. Before inserting a vial into the iOS system after operating in Online mode, slide the door open and wait 30 seconds to allow sample to completely drain. Inserting a vial before draining can result in hot water spray projecting upward out of the iOS system.
	This symbol indicates the protective earth terminal (ground) for the Analyzer.
	This symbol indicates the European Union Directive 2012/19/EU for waste electrical and electronic equipment (WEEE) requires disposing the Analyzer separately from standard waste.
	To avoid potentially dangerous shock, before opening the Analyzer, stop any analysis and power off the operating system. Press the <i>Power Off</i>  button in the Analyzer's firmware, then turn off the power switch and disconnect from the power supply. Any operation requiring access to the inside of the Analyzer without turning off power, including installation of maintenance items, could result in injury.
	To protect against accidental exposure to ultra-violet radiation, do not operate the UV lamp outside of its protective housing. The UV lamp housing may be hot. Use extreme caution whenever touching the UV lamp housing.
	Risk Group 3 Warning: UV emitted from this product. Avoid eye and skin exposure to unshielded product.

Warnings



The glass window in the UV reactor indicates proper lamp operation and should not be viewed too closely (closer than 6 inches) or for extended periods (greater than 1 minute). Protective eyewear is recommended.



If this instrument is used in a manner not specified by SUEZ, the protection provided by the instrument may be impaired.



To avoid injury and to ensure accurate analysis results, ensure that the Analyzer door is closed and latched during normal operation.



This symbol on the instrument indicates that the product does contain restricted substances included in China RoHS II. Please refer to the following table.

M500 TOC Analyzer
产品中有害物质的名称及含量

Table of Hazardous Substances' Name and Concentration

部件名称 Component Name	有害物质 Hazardous Substances' Name					
	铅 (Pb)	汞 (Hg)	镉 (Cd)	六价铬 (Cr(VI))	多溴联苯 (PBB)	多溴二苯醚 (PBDE)
紫外灯 - UV Lamp	O	X	O	O	O	O

本表格依据SJ/T 11364的规定编制。
This table is prepared according to SJ/T 11364.

O: 表示该有害物质在该部件所有均质材料中的含量均在 GB/T 26572规定的限量要求以下
X: 表示该有害物质至少在该部件的某一均质材料中的含量超出 GB/T 26572规定的限量要求

- 此表所列数据为发布时所能获得的最佳信息

O: Indicates that hazardous substance contained in all of the homogeneous materials for this part is below the limit requirement in GB/T 26572.

X: Indicates that the hazardous substance contained in at least one of the homogeneous materials used for this part is above the limit requirement in GB/T 26572.

- Data listed in the table represents best information available at the time of publication.

Please Note: This product contains a UV Lamp (with Hg) which meets the exemption defined in Annex III 4(a) of RoHS Directive 2011/65/EC.













To assure safe operation of the instrument, the AC Mains Earth Ground must be securely connected to the enclosure.



















Always stop analysis before turning off the Analyzer.

Warnings











	This is a Safety Class I product. It must be must be attached to a grounded power source. To avoid damage to the Analyzer and the chance of injury, make sure the Analyzer is connected to a power line of the proper voltage.
	This is a Class A product. In a domestic environment, this product may cause electromagnetic interference. Take adequate measures to correct the interference.
	Consult the MSDS that accompanies each standards set to identify proper disposal techniques.
	To avoid potentially dangerous shock, do not touch anything inside the Analyzer while observing the sample pump during a visual inspection.
	Take extreme care to avoid getting electrical components wet when performing this procedure.
	The UV lamp contains mercury and may be considered hazardous material in your local area. Dispose of these items in accordance with federal, state, or local government regulations.
	In the case of any broken or damaged UV lamp, handle the remains in accordance with your organization's toxic waste handling procedure and dispose of them in accordance with federal, state, or local government regulations.
	The WEEE Directive 2012/19/EU applies to batteries and requires their removal and separate collection. Once removed the used batteries are governed by the Battery Directive 2006/66/EC and its amendments. Dispose of the used batteries according to the manufacturer's instructions and local disposal/collection requirements.
	Operation of the Analyzer without the in-line filter on the sample inlet line will damage the Analyzer and void the warranty. To avoid damaging the Analyzer, install the filter and replace the filter element, as needed.
	Make sure the DI water reservoir is full, particularly when running samples with high TOC or high salt concentrations. After running high TOC or salt samples, always rinse the Analyzer by running low-TOC DI water through a sample cycle.
	Refer to the Analyzer's operation and maintenance manual for instructions on filling the DI water reservoir.

Warnings









	To avoid damage to the DI water pump, ensure that the DI water reservoir is filled before turning on the Analyzer.
	To avoid false TOC readings and possible damage to the Analyzer, always make sure the sample inlet is open and the DI water reservoir is filled before turning on the Analyzer.
	Always close the door of the iOS system when not sampling from a vial.
	To protect the Analyzer from damage, always drain the water from the Analyzer prior to shipping.
	<p>When cleaning the Analyzer, always apply liquid to the cloth directly, and do not spray liquids directly on the Analyzer.</p> <p>Do not use water or cleaners on the touchscreen, as water can damage or discolor the polarizer. Refer to the next section for recommendations on cleaning the touchscreen.</p> <p>Wipe away any condensation immediately.</p>
	Operating the Analyzer in Online mode with no sample flow and with the Flow Sensor off can result in erroneous measurements.
	Standards for the Sievers M500 TOC Analyzer are acidified. If preparing your own standards and using glass vials, ensure to acidify the standards to a pH of 3, or the system protocols will yield poor results.
	Ensure to center the vent tube within the tubing fittings to prevent pinching beneath the vent tube and prevent the sample from flowing.

Advertencias	
	Este símbolo en el instrumento indica que el usuario debe consultar el manual para conocer las instrucciones de funcionamiento.
	El Sistema iOS y los puertos de viales contienen dos agujas filosas diseñadas para perforar los septa de los viales con las muestras. NO ponga los dedos o materiales inadecuados dentro del Sistema iOS o el puerto de viales.
	El agua en el Sistema iOS puede estar caliente. Antes de introducir un vial en el Sistema iOS después de hacer funcionar el instrumento en modo en línea, deslice la puerta para abrirla y espere 30 segundos para que la muestra drene totalmente. Cuando se introduce un vial antes de drenar puede que el agua posiblemente caliente se expulse y salpique hacia arriba del Sistema iOS.
	Este símbolo indica el terminal de protección a tierra (masa) para el Analizador.
	Este símbolo indica que para cumplir con la Directriz de la Unión Europea 2012/19/EU relacionada con el desecho de equipos eléctricos y electrónicos (WEEE), el Analizador deberá desecharse por separado de los residuos comunes.
	Para evitar posibles descargas eléctricas, antes de abrir el analizador, detener todo análisis en marcha y apagar el sistema operativo. Pulsar el botón OFF  en el Firmware del analizador, luego apagar el interruptor de corriente y desconectar el instrumento del suministro de energía. Toda operación que necesite el acceso al interior del analizador sin que se desconecte la corriente eléctrica, incluyéndose la instalación de los elementos de mantenimiento, podría provocar lesiones.
	Para proteger contra la exposición accidental a la radiación de rayos ultravioletas, no ponga a funcionar la lámpara UV fuera de su carcasa de protección. La carcasa de la lámpara UV puede estar caliente. Téngase mucha precaución siempre que se toque dicha carcasa.
	Advertencia de grupo de riesgo 3: Rayos UV emitidos por este producto. Evitar la exposición de ojos y piel cuando el producto no esté protegido.





Advertencias









	La ventana de cristal en el reactor de rayos UV indica el funcionamiento correcto de la lámpara y no debe mirarse muy de cerca (a más de 15 cm [6 pg]) o durante un tiempo excesivo (más de un minuto). Se recomienda el uso de protección ocular.
	Si este instrumento se utiliza de una manera que no sea la especificada por SUEZ, es posible que se vea disminuida la protección de seguridad provista por el instrumento.
	Para impedir que se produzcan lesiones y para garantizar resultados de análisis exactos, se debe asegurar que la puerta del analizador esté cerrada y trabada durante el funcionamiento normal del instrumento.
	Para garantizar el funcionamiento seguro del instrumento, la descarga a tierra del suministro de CA debe estar perfectamente conectada al gabinete.
	Siempre detener el análisis antes de apagar el analizador.
	Este es un producto con seguridad de Clase I. Se debe instalar a un suministro de alimentación con descarga a tierra. Para evitar daños al analizador y la posibilidad de sufrir lesiones, asegurarse de que el instrumento esté conectado a una línea de alimentación de la tensión correcta.
	Este es un producto de Clase A. En un entorno residencial, este producto puede que cause interferencia electromagnética. Tome las medidas adecuadas para corregir la interferencia.
	Consulte las MSDS que acompañan a cada estándar para identificar las técnicas correctas de desecho.
	Para prevenir una posible descarga eléctrica, no tocar nada dentro del analizador mientras se observa la bomba de muestras durante una inspección visual.
	Tener un cuidado excesivo para impedir que se mojen los componentes eléctricos cuando se realice este procedimiento.
	La lámpara UV contiene mercurio y puede considerarse material peligroso en su área local. Desechar la lámpara UV de conformidad con la normativa del gobierno federal, estatal o local

Advertencias











	Si la lámpara UV se rompe o deteriora, los restos de la misma deben manejarse de conformidad con el procedimiento de manejo de residuos tóxicos de su compañía y desecharse conforme a la normativa del gobierno federal, estatal o local.
	La Directiva de residuos de aparatos eléctricos y electrónicos (WEEE por sus siglas en inglés) 2012/19/EU aplica a las baterías y requiere su retiro y recolección por separado. Una vez que se retiran, las baterías usadas se someten para su tratamiento a la Directiva relativa a baterías 2006/66/CE y sus enmiendas. Desechar las baterías usadas conforme a las instrucciones del fabricante y los requisitos locales relacionados con el desecho y la recolección.
	El funcionamiento del Analizador sin el filtro en línea en el conducto de entrada de muestra dañará el Analizador y anulará la garantía. Para evitar los daños al Analizador, instale el filtro y reemplace el elemento filtrante según sea necesario.
	Asegúrese de que el reservorio de agua DI (pizeta) esté lleno, en especial cuando se analizan muestras con TOC elevado o altas concentraciones de sal. Después de analizar muestras con TOC elevado o alto contenido de sal, siempre enjuague el Analizador haciendo correr agua DI de bajo TOC por el ciclo de muestra.
	Consultar el manual de operación y mantenimiento del analizador para obtener las instrucciones acerca del llenado del depósito de agua DI.
	Para prevenir daños a la bomba de agua DI, asegúrese de que el reservorio de agua DI (pizeta) esté lleno antes de encender el Analizador.
	Para evitar lecturas falsas de TOC y posible daño en el analizador, cerciorarse siempre de que la entrada de muestras esté abierta y el depósito de agua DI esté lleno antes de encender el analizador.
	Siempre cerrar la puerta del sistema iOS cuando no se estén tomando muestras de un vial.
	Para proteger el analizador contra posibles daños, siempre vaciar el agua del mismo antes de despacharlo.

Advertencias









	<p>Cuando se limpie el Analizador, siempre ponga el líquido directamente en el paño y no pulverice líquidos directamente sobre el Analizador.</p> <p>No utilice agua ni limpiadores sobre la pantalla táctil, puesto que el agua puede deteriorar o decolorar el polarizador. Consulte con la sección siguiente para conocer las recomendaciones sobre la limpieza de la pantalla táctil.</p> <p>Seque toda condensación de inmediato.</p>
	<p>Cuando se haga funcionar el analizador en modo En línea sin que haya caudal de muestras y con el sensor de flujo apagado se pueden obtener mediciones erróneas.</p>
	<p>Los estándares para el Analizador de TOC Sievers M500 En línea son acidificados. Si se preparan estándares propios y se utilizan viales de cristal, asegurarse de acidificar dichos estándares a un pH de 3, de lo contrario los protocolos de sistema producirán resultados deficientes.</p>
	<p>Garantizar el centrado del tubo de respiradero dentro de las conexiones de tuberías para evitar pellizcos debajo de ese tubo e impedir que derrame la muestra.</p>

Avertissements	
	Ce symbole sur les instruments indique que l'utilisateur doit se reporter au manuel pour obtenir des instructions d'utilisation.
	Le système iOS et les ports d'injection des flacons contiennent des aiguilles aiguisées, conçues pour percer la membrane des flacons d'échantillons. Ne pas mettre les doigts ou des matériaux non appropriés dans le système iOS ou dans les ports d'injection des flacons.
	L'eau dans le système iOS peut-être chaude. Avant d'introduire un flacon dans le système iOS fonctionnant en mode On-Line, faire glisser le capôt pour ouvrir l'iOS et attendre 30 secondes pour que l'échantillon se vide complètement. L'insertion d'un flacon avant la fin du drainage risque de projeter de l'eau potentiellement chaude vers le haut et hors du système iOS.
	Ce symbole marque la borne de mise à terre de l'analyseur.
	Ce symbole indique que pour la conformité avec la directive 2012/19/EU de l'Union Européenne concernant les matériels électroniques et électriques mis au rebut, l'analyseur doit être éliminé séparément des déchets standards.
	Pour éviter tout choc potentiellement dangereux, avant d'ouvrir l'analyseur, arrêtez toute analyse et mettez le système de fonctionnement hors tension. Appuyez sur le bouton « Power Off »  dans le micrologiciel de l'analyseur, puis éteignez l'interrupteur d'alimentation et débranchez l'appareil de l'alimentation électrique. Toute opération nécessitant l'accès à l'intérieur de l'analyseur sans couper l'alimentation, notamment l'installation d'éléments de maintenance, peut entraîner des blessures.
	Pour éviter les expositions accidentelles aux rayons ultra-violet, ne pas utiliser la lampe à UV hors de son boîtier de protection. Le boîtier de la lampe UV peut être chaud. Faites preuve d'une extrême prudence lorsque vous touchez le boîtier de la lampe UV.
	Avertissement du groupe de risque 3 : UV émis par ce produit. Évitez l'exposition des yeux et de la peau au produit non blindé.





Avertissements









	La fenêtre en verre du réacteur UV indique le bon fonctionnement de la lampe et ne doit pas être regardée de trop près (moins de 15 cm) ou pendant de longues périodes (plus d'une minute). L'utilisation de lunettes de protection est recommandée.
	Si cet instrument n'est pas utilisé en conformité avec les recommandations de SUEZ, la protection de la sécurité des personnes peut être compromise.
	Pour éviter les blessures et garantir des résultats d'analyse exacts, assurez-vous que la porte de l'analyseur est fermée et verrouillée pendant le fonctionnement normal.
	Pour assurer un fonctionnement sûr de l'appareil, la mise à la terre principale du secteur doit être solidement connectée au boîtier.
	Arrêtez toujours l'analyse avant d'éteindre l'analyseur.
	Il s'agit d'un appareil de classe de sécurité I. Il doit être raccordé à une source d'alimentation électrique mise à la terre. Pour éviter tout dommage à l'analyseur et tout risque de blessure, assurez-vous que l'analyseur est connecté à une ligne d'alimentation électrique de la tension appropriée.
	Cet équipement correspond à la classe A de la FCC. Dans un environnement domestique, cet équipement risque de causer des interférences électromagnétiques. Prendre les mesures appropriées pour corriger ces interférences.
	Consultez la fiche signalétique (MSDS) qui accompagne chaque norme établie pour identifier les techniques d'élimination appropriées.
	Pour éviter tout choc potentiellement dangereux, ne touchez à rien à l'intérieur de l'analyseur lorsque vous observez la pompe à échantillon lors d'une inspection visuelle.
	Faites très attention à ne pas mouiller les composants électriques lorsque vous réalisez cette procédure.
	La lampe UV contient du mercure et peut être considérée comme une matière dangereuse dans votre environnement local. Éliminez ces articles conformément aux réglementations fédérales, provinciales ou locales.

Avertissements

	Si la lampe UV est cassée ou endommagée, elle doit être manipulée conformément à la procédure de manipulation des déchets toxiques de votre établissement et éliminée conformément aux réglementations gouvernementales fédérales, nationales ou locales en vigueur.
	La directive DEEE 2012/19/UE s'applique aux piles et exige leur retrait et leur collecte séparée. Une fois retirées, les piles usagées sont régies par la directive 2006/66/CE sur les piles, et par ses amendements. Éliminez les piles usagées conformément aux instructions du fabricant et aux exigences locales en matière d'élimination et de collecte.
	L'utilisation de l'analyseur sans le filtre en ligne sur la tubulure d'entrée d'échantillon peut endommager l'analyseur et annule de ce fait la garantie. Pour éviter d'endommager l'analyseur, installer le filtre et remplacer l'élément filtrant quand nécessaire.
	Vérifier que le réservoir d'eau DI soit plein, notamment lorsque l'analyse d'échantillons à forte teneur en COT ou de sel est réalisée.. Après l'analyse d'un échantillon à concentration élevée en COT ou en sels, toujours rincer l'analyseur en exécutant un cycle d'analyse avec un échantillon contenant de l'eau ultrapure.
	Consultez le manuel de fonctionnement et de maintenance de l'analyseur pour obtenir des instructions sur le remplissage du réservoir d'eau DI.
	Pour éviter d'endommager la pompe à eau DI, s'assurer que le réservoir d'eau DI soit bien rempli avant d'allumer l'analyseur.
	Pour éviter les fausses lectures du COT et les dommages éventuels causés à l'analyseur, assurez-vous toujours que le port d'entrée est ouvert et que le réservoir d'eau DI est rempli avant de mettre l'analyseur en marche.
	Fermez toujours la porte du Système IOS lorsque vous ne prélevez pas d'une fiole.
	Pour protéger l'analyseur contre les dommages, drainez toujours l'eau de l'analyseur avant de l'expédier.

Avertissements









	<p>Lors du nettoyage de l'Analyseur, appliquez toujours du liquide au chiffon directement, et ne pulvérisez pas de liquide directement sur l'Analyseur.</p> <p>N'utilisez pas d'eau ou de nettoyant sur l'écran tactile, l'eau peut endommager ou décolorer le polariseur. Consultez la section suivante pour lire les recommandations concernant le nettoyage de l'écran tactile.</p> <p>Essayez immédiatement toute condensation.</p>
	<p>Faire fonctionner l'analyseur en mode en ligne sans aucun débit d'échantillon et avec le capteur de débit éteint peut entraîner des mesures erronées.</p>
	<p>Les standards de l'analyseur COT en ligne Sievers M500 sont acidifiés. Si vous préparez vos propres standards et utilisez des fioles en verre, assurez-vous d'acidifier les étalons à un pH de 3, sinon les protocoles du système donneront de mauvais résultats.</p>
	<p>Veillez à centrer le tube d'aération dans les raccords de tubes pour éviter qu'il ne se pince sous le tube d'aération et que l'échantillon ne s'écoule.</p>

Warnhinweise	
	Dieses Symbol auf dem Gerät zeigt an, dass der Benutzer die Betriebsanweisungen in der Anleitung nachschlagen soll.
	Das iOS-System sowie die einzelnen Probeneingänge enthalten scharfe Nadeln, die dafür ausgelegt sind, die Septen der Probenfläschchen zu durchstechen. Halten Sie NICHT die Finger oder andere ungeeignete Materialien in das iOS-System oder den Probeneingang.
	Das Wasser im iOS-System kann heiß sein. Warten Sie vor dem Einführen eines Probenfläschchens in das iOS-System nach Betrieb im Online-Modus 30 Sekunden, bis die Probe vollständig abgelaufen ist. Das Einführen eines Probenfläschchens vor dem Ablaufen kann dazu führen, dass heißes Wasser aus dem iOS-System nach oben spritzt.
	Dieses Symbol zeigt den Schutzleiter (Erde) des Analysators an.
	Dieses Symbol zeigt an, dass der Analysator gemäß der EU-Richtlinie 2012/19/EU zur Entsorgung von Elektro- und Elektronik-Altgeräten getrennt vom Normalmüll zu entsorgen ist.
	Um einen potenziell gefährlichen Schock zu vermeiden, stoppen Sie vor dem Öffnen des Analysegeräts jegliche Analyse und schalten Sie das Betriebssystem aus. Drücken Sie die Ausschalttaste in der Firmware des Analysators, schalten Sie dann den Netzschalter aus und trennen Sie die Verbindung zur Stromversorgung. Jeder Vorgang, der Zugang zum Inneren des Analysators erfordert, ohne den Strom abzuschalten, einschließlich der Installation von Wartungskomponenten, kann zu Verletzungen führen.
	Betreiben Sie zum Schutz gegen versehentliche Exposition mit UV-Strahlung die UV-Lampe nicht außerhalb ihres Sicherheitsgehäuses. Das Gehäuse der UV-Lampe kann heiß sein. Seien Sie äußerst vorsichtig, wenn Sie das Gehäuse der UV-Lampe berühren.
	Risikogruppe 3 Warnung: Dieses Produkt emittiert UV-Strahlung. Augen- und Hautexposition durch nicht abgeschirmtes Produkt vermeiden.





Warnhinweise











	Das Glasfenster im UV-Reaktor zeigt den ordnungsgemäßen Lampenbetrieb an und sollte nicht aus zu geringem Abstand (weniger als 15 cm (6 Zoll)) oder über längere Zeiträume (länger als 1 Minute) betrachtet werden. Eine Schutzbrille wird empfohlen.
	Wenn dieses Gerät auf eine Weise verwendet wird, die von SUEZ nicht spezifiziert ist, kann die Sicherheit beeinträchtigt werden.
	Um Verletzungen zu vermeiden und genaue Analyseergebnisse zu gewährleisten, stellen Sie sicher, dass die Tür des Analysators während des normalen Betriebs geschlossen und verriegelt ist.
	Um einen sicheren Betrieb des Geräts zu gewährleisten, muss die Schutz Erde der Stromversorgung sicher mit dem Gehäuse verbunden sein.
	Vor dem Ausschalten des Analysators immer laufende Analysen stoppen.
	Dies ist ein Produkt der Schutzklasse I. Es muss an eine geerdete Stromquelle angeschlossen werden. Um Schäden am Analysator und die Gefahr von Verletzungen zu vermeiden, stellen Sie sicher, dass der Analysator an eine Stromversorgung mit der richtigen Spannung angeschlossen ist.
	Dies ist ein Klasse A-Produkt. In einer häuslichen Umgebung kann dieses Produkt elektromagnetische Störungen verursachen. Ergreifen Sie geeignete Maßnahmen, um diese Störungen zu korrigieren.
	Entnehmen Sie die ordnungsgemäßen Entsorgungsverfahren jeweils dem Sicherheitsdatenblatt, das jedem Standard-Kit beiliegt.
	Um einen möglicherweise gefährlichen Stromschlag zu vermeiden, berühren Sie nichts im Inneren des Analysators, während Sie die Probenpumpe bei einer visuellen Inspektion beobachten.
	Seien Sie äußerst vorsichtig, um zu vermeiden, dass elektrische Komponenten bei der Durchführung dieses Verfahrens nass werden.
	Die UV-Lampe enthält Quecksilber und kann in Ihrer Region als Gefahrstoff angesehen werden. Entsorgen Sie diese Gegenstände gemäß Ihren staatlichen und lokalen Vorschriften.

Warnhinweise











	Behandeln Sie im Fall einer defekten oder beschädigten UV-Lampe die Überreste gemäß der Verfahren zur Behandlung toxischer Abfälle Ihres Unternehmens und entsorgen Sie sie gemäß Bundes-, Staats- bzw. lokaler Bestimmungen.
	Die WEEE-Richtlinie 2012/19/EU gilt für Batterien und verlangt ihre Entfernung und getrennte Sammlung. Nach ihrer Entfernung unterliegen die gebrauchten Batterien der Batterierichtlinie 2006/66/EG und ihren Änderungen. Entsorgen Sie die gebrauchten Batterien gemäß den Anweisungen des Herstellers und den örtlichen Entsorgungs-/Sammelvorschriften.
	Der Betrieb des Analysators ohne Inline-Filter an der Probeneinlassleitung führt zur Beschädigung des Analysators und lässt die Garantie erlöschen. Installieren Sie zur Vermeidung von Schäden am Analysator den Inline-Filter und tauschen Sie das Filterelement nach Bedarf aus.
	Stellen Sie sicher, dass der DI-Wassertank gefüllt ist, insbesondere bei Probenläufen mit hohem TOC-Gehalt oder hohen Salzkonzentrationen. Spülen Sie den Analysator nach dem Lauf von Proben mit hohem TOC- oder Salzgehalt immer mit DI-Wasser mit niedrigem TOC-Gehalt über einen Probenzyklus.
	Anweisungen zum Befüllen des DI-Wasserbehälters finden Sie im Bedienungs- und Wartungshandbuch des Analysators.
	Stellen Sie zur Vermeidung einer Beschädigung der DI-Wasserpumpe vor dem Einschalten des Analysators sicher, dass das der DI-Wassertank gefüllt ist.
	Um falsche TOC-Messwerte und mögliche Schäden am Analysator zu vermeiden, stellen Sie immer sicher, dass der Probeneinlass offen und der DI-Wasserbehälter gefüllt ist, bevor Sie den Analysator einschalten.
	Schließen Sie immer die Tür des iOS-Systems, wenn Sie keine Proben aus einem Fläschchen entnehmen.
	Um den Analysator vor Beschädigung zu schützen, sollte das Wasser vor dem Versand immer aus dem Analysator abgelassen werden.

Warnhinweise



	<p>Geben Sie zum Reinigen des Analysators die Flüssigkeit immer auf ein Tuch und sprühen Sie Flüssigkeiten nicht direkt auf den Analysator.</p> <p>Verwenden Sie für den Touchscreen KEIN Wasser und KEINE Reinigungsmittel, da Wasser den Polarisator beschädigen oder entfärben kann. Im nächsten Abschnitt finden sich Empfehlungen zum Reinigen des Touchscreens.</p> <p>Wischen Sie etwaige Kondensate sofort ab.</p>
	<p>Der Betrieb des Analysators im Online-Modus ohne Probenfluss und mit ausgeschaltetem Durchflusssensor kann zu fehlerhaften Messungen führen.</p>
	<p>Die Standards für den TOC-Analysator Sievers M500 sind angesäuert. Wenn Sie Ihre eigenen Standards vorbereiten und Glasfläschchen verwenden, stellen Sie sicher, dass die Standards auf einen pH-Wert von 3 angesäuert werden, da die Systemprotokolle sonst schlechte Ergebnisse liefern.</p>
	<p>Achten Sie darauf, den Entlüftungsschlauch innerhalb der Rohrverschraubungen zu zentrieren, um ein Einklemmen unter dem Entlüftungsschlauch zu verhindern und damit den Probenfluss möglicherweise zu unterbinden.</p>

Avvertenze	
	Questo simbolo sullo strumento indica che l'utente deve fare riferimento al manuale per le istruzioni d'uso.
	Il sistema iOS e le porte delle fiale contengono aghi taglienti atti a perforare i setti delle fiale di campioni. Non mettere le dita o materiali inadatti all'interno del sistema iOS o della porta della fiala.
	L'acqua all'interno del sistema iOS potrebbe essere calda. Prima di inserire una fiala all'interno del sistema iOS dopo il funzionamento in modalità online, aprire lo sportello e attendere 30 secondi per consentire al campione di defluire completamente. L'inserimento di una fiala prima del prosciugamento può comportare la fuoriuscita di spruzzi d'acqua verso l'alto dal sistema iOS.
	Questo simbolo indica il terminale del conduttore di protezione (terra) dell'Analizzatore.
	Questo simbolo indica che la Direttiva dell'Unione Europea 2012/19/EU sui rifiuti di apparecchiature elettriche ed elettroniche (WEEE) prevede lo smaltimento separato dell'Analizzatore rispetto ai rifiuti standard.
	Per evitare shock potenzialmente pericolosi, prima di aprire l'Analizzatore, interrompere l'analisi e spegnere il sistema operativo. Premere il pulsante Power Off  (spegnimento) nel firmware dell'Analizzatore, quindi spegnere l'interruttore e scollegarlo dall'alimentazione. Le operazioni che richiedono l'accesso all'interno dell'Analizzatore senza spegnimento, compresa l'installazione di componenti per la manutenzione, potrebbero causare lesioni.
	Per proteggersi dall'esposizione accidentale alle radiazioni ultraviolette, non azionare la lampada UV fuori dal suo alloggiamento protettivo. L'alloggiamento della lampada UV potrebbe essere caldo. Fare molta attenzione se si deve toccare l'alloggiamento della lampada UV.
	Gruppo di rischio 3 Avvertenza: Questo prodotto emette raggi UV. Evitare l'esposizione di occhi e pelle con il prodotto non schermato.
	La finestrella di vetro nel reattore UV indica un corretto funzionamento della lampada e non deve essere osservata troppo da vicino (non oltre 6 poll. (15 cm.)) o per periodi prolungati (non oltre 1 minuto). Si consiglia l'uso di occhiali protettivi.

Avvertenze

	Se lo strumento viene utilizzato secondo modalità non indicate da SUEZ, la protezione di sicurezza fornita dallo strumento potrebbe risultarne compromessa.
	Per evitare lesioni e per garantire l'accuratezza dei risultati dell'analisi, accertarsi che lo sportello dell'Analizzatore sia chiuso durante il normale funzionamento.
	Per garantire il funzionamento in sicurezza dello strumento, la messa a terra della conduttura CA deve essere ben collegata all'alloggiamento.
	Interrompere sempre l'analisi prima di spegnere l'Analizzatore.
	Questo è un prodotto Classe di sicurezza I. Deve essere collegato a una fonte di alimentazione con messa a terra. Per evitare danni all'Analizzatore e il rischio di lesioni, accertarsi che l'Analizzatore sia collegato a una linea elettrica con tensione adeguata.
	Questo è un prodotto di Classe A. In un ambiente domestico, questo prodotto può causare interferenza elettromagnetica. Prendere le misure adeguate per eliminare l'interferenza.
	Consultare l'MSDS allegata a ogni set di standard per identificare tecniche di smaltimento adeguate.
	Per evitare scosse potenzialmente pericolose, non toccare l'interno dell'Analizzatore durante il controllo visivo della pompa di campionamento.
	Inoltre, evitare assolutamente di bagnare i componenti elettrici durante l'esecuzione di questa procedura.
	La lampada UV contiene mercurio, materiale che nella propria area potrebbe essere considerato pericoloso. Smaltire questi materiali in conformità alle leggi statali o locali.
	In caso di lampada UV danneggiata o rotta, gestire i pezzi in conformità alla procedura di smaltimento rifiuti tossici della propria azienda e smaltirli in conformità ai regolamenti locali, statali o federali.

Avvertenze

	Alle batterie si applica la Direttiva WEEE 2012/19/UE che richiede la rimozione e raccolta separata. Le batterie usate e rimosse sono disciplinate dalla Direttiva sulle batterie 2006/66/CE e relativi emendamenti. Smaltire le batterie usate in base alle indicazioni del produttore e ai regolamenti locali per la raccolta e lo smaltimento.
	L'azionamento dell'Analizzatore senza filtro in linea sulla linea di alimentazione del campione danneggia l'Analizzatore e invalida la garanzia. Per evitare danni all'Analizzatore, installare il filtro e sostituire l'elemento filtrante, secondo necessità.
	Accertarsi che il serbatoio di acqua deionizzata sia pieno, in particolare quando si adoperano campioni con un'elevata concentrazione di TOC o di sale. Dopo aver usato campioni con elevate concentrazioni di TOC o di sale, sciacquare sempre l'Analizzatore con acqua deionizzata a basso contenuto di TOC in un ciclo di campionamento.
	Fare riferimento al manuale di manutenzione e funzionamento dell'Analizzatore per istruzioni sul riempimento del serbatoio di acqua DI.
	Per evitare danni alla pompa di acqua deionizzata, accertarsi che il serbatoio di acqua deionizzata sia pieno prima di accendere l'Analizzatore.
	Per evitare false letture del TOC e possibili danni all'Analizzatore, accertarsi sempre che l'ingresso del campione sia aperto e che il serbatoio di acqua DI sia pieno prima di accendere l'Analizzatore.
	Chiudere sempre lo sportello del sistema iOS quando non si effettua il campionamento da una fiala.
	Per proteggere l'Analizzatore da danni, drenare sempre l'acqua dall'Analizzatore prima di spedirlo.
	<p>Durante la pulizia dell'analizzatore, applicare sempre il liquido sul panno invece di spruzzarlo direttamente sull'Analizzatore.</p> <p>Non usare acqua o detersivi sul touchscreen. L'acqua potrebbe danneggiare o decolorare il polarizzatore. Fare riferimento alla sezione successiva per raccomandazioni sulla pulizia del touchscreen.</p> <p>Rimuovere immediatamente la condensa.</p>
	Avviare l'Analizzatore in modalità Online senza flusso di campione e con il Sensore di flusso spento potrebbe causare errori di misurazione.

Avvertenze



Gli standard per l'Analizzatore di TOC Online Sievers M500 sono acidificati. Se l'utente prepara i propri standard e utilizza fiale di vetro, gli standard devono essere acidificati a un pH di 3 o i protocolli del sistema daranno risultati scarsi.



Accertarsi di centrare il tubo di sfiato all'interno dei raccordi dei tubi per evitare schiacciamenti sotto il tubo di sfiato ed evitare che il campione fluisca.

日本語

警告	
	機器についているこの記号は、ユーザーが操作説明書を参照する必要があることを示します。
	iOS システムおよびバイアル ポートには、サンプル バイアルのセプタムを穿孔するように設計された鋭利なニードルがあります。指や不適切な物質を iOS システムやバイアル ポートに入れないようにしてください。
	iOS システム内の水温が上昇している場合があります。オンラインモードでの運転後にバイアルを iOS システムに挿入する前に、ドアをスライドさせて開け、30 秒間待ち、サンプルが完全に排水されるようにしてください。排水前にバイアルを挿入すると、iOS システムから熱水が上向きに噴出する恐れがあります。
	このマークは、分析装置の保護アース端子（接地）を示しています。
	この記号は、廃電気電子機器 (WEEE) に関する EU 指令 2012/19/EU に関するものであり、分析装置を適切に処分することが求めていることを示します。
	潜在的に危険な感電を避けるため、分析装置を開ける前に、分析を停止してオペレーティング システムの電源を切ります。分析装置のファームウェアの電源オフ (Power Off ) ボタンを押し、次に電源スイッチを切り、電源から切り離します。保守品目の取り付けを含む、電源を切らずに分析装置内部にアクセスするいかなる操作も、人身傷害につながる可能性があります。
	紫外線への偶発的な曝露から身を守るために、保護筐体の外で UV ランプを作動させないでください。UV ランプ ハウジングは高温になる可能性があります。UV ランプ ハウジングに触れる時はいつでも、特に注意してください。
	リスク グループ 3 警告：本製品から放射された紫外線。遮蔽されていない製品への眼や皮膚の暴露を避けてください。
	UV ランプが正常に動作しているかどうかは、UV 反応器のガラス窓で確認できます。目を近づけすぎたり (15 cm 以下)、長時間 (1 分以上) 見つめたりしないでください。保護用眼鏡の装着をお勧めします。
	SUEZ が指定した方法で機器を使用しない場合は、機器に設けられた安全保護機能が損なわれる可能性があります。

警告

	怪我を避けるため、そして正確な分析結果を確保するために、分析装置のドアを必ず閉め、通常運転中には掛け金を掛けるようにしてください。
	装置の安全な操作を確保するために、AC 電源アース接地線を筐体にしっかりと接続する必要があります。
	分析は、必ず分析機器の電源を切る前に停止してください。
	これは、安全等級 I 製品です。接地電源に接続する必要があります。分析機器の破損と人体傷害を回避するため、分析機器を正しい電圧の電力線に接続するようにしてください。
	これはクラス A の製品です。家庭環境では、本製品が電磁干渉を引き起こす可能性があります。適切な対策を取り、干渉を是正してください。
	適切な廃棄処理方法については、各標準液セットに付随する MSDS を参照してください。
	潜在的に危険な感電を避けるため、目視検査中にサンプル ポンプを観察している間は分析装置内部のどこにも触れてはいけません。
	この手順を行う際、電気部品が濡れないように特に注意してください。
	UV ランプには水銀が含まれており、お住まいの地域では有害物質に指定されている可能性があります。これらの部品は、国や地方自治体の規制に従って処分してください。
	UV ランプが破損、または損傷した場合は、社内の有害廃棄物取扱手順に従って残留物を取り扱い、国、都道府県、または地方自治体の規則に従って処分してください。
	WEEE 指令 2012/19/EU がバッテリーに適用され、その取り外しと分別回収を必要とします。取り外し次第、使用済み電池はバッテリー指令 2006/66/EC とその改正指令によって管理されます。メーカーの指示と現地の廃棄 / 回収要件に従って使用済みバッテリーを廃棄してください。
	サンプル注入ラインにインライン フィルターを付けずに分析装置を操作した場合は、分析装置に損傷を与え、保証が無効になることがあります。分析装置の損傷を防ぐために、フィルターを取り付け、必要に応じてフィルター エレメントを交換してください。
	DI 水リザーバーが満杯になっていることを確認してください。特に、TOC または塩濃度が高いサンプルを使用した後は、必ず、低 TOC の脱イオン水を用いて、分析装置の内部流路をリンスしてください。

警告

	DI 水リザーバーの補充に関する説明については、分析装置の操作および保守マニュアルを参照してください。
	DI 水ポンプの損傷を防ぐため、分析装置の電源を入れる前に、DI 水リザーバーが満杯であることを確認してください。
	誤った TOC 測定値および分析装置に対する損傷の可能性を避けるために、分析装置の電源を入れる前に、サンプル注入口が開いていて、DI 水リザーバーが満杯になっていることを必ず確認してください。
	バイアルからサンプリングを行っていない時は、iOS システムのドアを常に閉めてください。
	分析装置を損傷から守るために、必ず輸送前に分析装置から水を排出してください。
	分析装置を洗浄する場合、必ず液体は布に直接付けてください。そして、分析装置には液体を直接噴霧しないでください。 水が偏光板に損傷を与えたり、変色させる可能性があるため、タッチスクリーンに水またはクリーナーを使用しないでください。タッチスクリーンの洗浄に関する推奨事項については、次のセクションを参照してください。 凝縮物は直ちに拭き取ってください。
	サンプルの流れがなく、流量センサーがオフの状態ではオンラインモードで分析装置を操作すると、謝った測定につながる可能性があります。
	Sievers M500 オンライン TOC 分析装置用の標準液は酸性化されています。独自の標準液を調製して、ガラス バイアルを使用する場合、標準液を必ず pH 3 に酸性化してください。そうしないと、システムプロトコルが不正確な結果を生じることになります。
	ベント チューブの下で挟むのを避け、サンプルの流れを妨げないように、必ずベント チューブをチューブ継ぎ手内の中心に置きます。

경고	
	기기에 이 기호가 있으면 사용자가 작동 지침을 위해 설명서를 참조해야 함을 의미합니다 .
	iOS 시스템 및 바이얼 포트에는 시료 바이얼의 격막을 뚫도록 설계된 날카로운 바늘이 포함되어 있습니다 . iOS 시스템 또는 바이얼 포트에 손가락 또는 부적절한 물질을 집어넣지 마십시오 .
	iOS 시스템 안에 있는 물은 뜨거울 수 있습니다 . 온라인 모드에서 작동한 후 iOS 시스템에 바이얼을 삽입하기 전에 도어를 밀어 연 다음 시료가 완전히 배출되도록 30 초간 기다리십시오 . 배출하기 전에 바이얼을 삽입하면 iOS 시스템에서 뜨거운 물이 튀어 오를 수 있습니다 .
	이 기호는 분석기를 위한 보호 접지 단자 (접지) 를 나타냅니다 .
	이 기호는 유럽연합 전기전자장비 폐기물 (WEEE) 지침 2012/19/EU 에 따라 분석기를 일반 폐기물과 분리하여 폐기해야 함을 나타냅니다 .
	위험해질 가능성이 있는 쇼크 상황을 방지하려면 분석기를 열기 전에 모든 분석을 중지하고 운영 체계를 끄십시오 . 분석기 펌웨어의 전원 끄기 버튼을 누른 다음 전원 스위치를 끄고 전원 공급 장치에서 분리하십시오 . 유지보수 품목 설치를 포함하여 전원을 끄지 않고 분석기 내부에 접근해야 하는 작업은 부상을 초래할 수 있습니다 .
	우발적인 자외선 복사 노출을 방지하기 위해 보호 하우징 외부에서는 자외선 램프를 작동하지 마십시오 . 자외선 램프 하우징은 뜨거울 수 있습니다 . 자외선 램프 하우징을 만질 때마다 각별히 주의하십시오 .
	위험 그룹 3 경고 : 이 제품에서는 자외선이 방출됩니다 . 차폐되지 않은 제품에 대한 눈 및 피부 노출을 피하십시오 .
	자외선 반응기의 유리 창은 적절한 램프 작동을 나타내며 너무 가깝게 (6 inch 이내) 또는 오랫동안 (1분 이상) 쳐다봐서는 안 됩니다 . 보호 안경이 권장됩니다 .
	이 기기를 당사에서 규정하지 않은 방식으로 사용할 경우 기기가 제공하는 안전 보호 장치가 손상될 수 있습니다 .











경고

	부상을 방지하고 정확한 분석 결과를 보장하려면 정상 작동 시 분석기 도어를 닫고 걸쇠로 잠그십시오 .
	기기의 안전한 작동을 보장하려면 AC 주전원 어스 접지를 인클로저에 단단히 연결해야 합니다 .
	항상 분석기를 끄기 전에 분석을 멈추십시오 .
	이 기기는 안전 클래스 I 제품입니다 . 이 기기는 접지된전원에 연결되어야 합니다 . 분석기 손상 및 부상 위험을피하기 위해 분석기가 적절한 전압의 전원선에 연결되어있는지 확인하십시오 .
	이 기기는 클래스 A 제품입니다 . 가정 환경에서는 이제품이 전자파장해를 초래할 수 있습니다 . 적절한 장해제거 조치를 실행하십시오 .
	적절한 폐기 방법을 확인하기 위해 각 표준에 동반된 MSDS 를 참조하십시오 .
	위험한 쇼크를 방지하기 위해 육안 검사 시 시료 펌프를 관찰하는 동안 분석기 내부에서 아무것도 만지지 마십시오 .
	이 절차를 수행할 때 전기 부품이 젖지 않도록 각별히주의하십시오 .
	자외선 램프는 수은을 포함하고 있으며 사용 지역에서위험물로 간주될 수 있습니다 . 연방·주·지방 정부 규정에따라 이 항목들을 폐기하십시오 .
	자외선 램프 파손 또는 손상 시에는 기관별 유독성 폐기물 취급 절차에 따라 남은 부분을 처리하고 연방 , 주 , 지방 정부 규정에 따라 폐기하십시오 .
	배터리의 분리 및 별도 수거를 요구하는 WEEE 지침 2012/19/EU 가 배터리에 적용됩니다 . 사용된 배터리가 분리된 후에는 배터리 지침 2006/66/EC 및 그 개정안의 지배를 받습니다 . 제조업체의 지침 및 지역 폐기 / 수거 요구 사항에 따라 사용된 배터리를 폐기하십시오 .
	시료 입구 라인에 인라인 필터가 없이 분석기를 작동하면 분석기가 손상될 수 있으며 보증이 무효화됩니다 . 분석기 손상을 방지하기 위해 필터를 설치하고 필요할 경우 필터 요소를 교체하십시오 .











경고

	특히 TOC 또는 염분 농도가 높은 시료를 돌릴 때는 탈이온수 탱크를 가득 채우십시오 . TOC 또는 염분이 높은 시료를 돌린 후에는 항상 저 TOC 탈이온수를 시료 사이클에 통과시켜 분석기를 세척하십시오 .
	탈이온수 탱크 충전에 관한 지침은 분석기 사용 및 유지보수 설명서를 참조하십시오 .
	탈이온수 펌프 손상을 방지하기 위해 분석기를 켜기 전에 탈이온수 탱크가 채워져 있는지 확인하십시오 .
	TOC 판독 오류 및 분석기 손상을 방지하기 위해 분석기를 켜기 전에 항상 시료 입구가 열려 있고 탈이온수 탱크가 채워져 있는지 확인하십시오 .
	바이얼에서 시료를 채취하지 않을 때는 항상 iOS 시스템의 도어를 닫으십시오 .
	분석기를 손상으로부터 보호하기 위해 운송하기 전에 항상 분석기에서 물을 배출하십시오 .
	<p>분석기를 청소할 때는 항상 액체를 천에 직접 묻히고 분석기에 직접 분무하지 마십시오 .</p> <p>물로 인해 편광자가 손상되거나 변색될 수 있기 때문에 터치스크린에 물 또는 세제를 사용하지 마십시오 . 터치스크린 청소에 관한 지침은 다음 섹션을 참조하십시오 .</p> <p>물방울은 즉시 닦아내십시오 .</p>
	시료 흐름이 없고 유량 센서가 꺼진 상태에서 분석기를 온라인 모드로 작동하면 측정 오류를 초래할 수 있습니다 .
	Sievers M500 온라인 TOC 분석기를 위한 표준 용액은 산성화됩니다 . 자신만의 표준 용액을 준비하고 유리 바이얼을 사용할 경우 표준 용액을 pH 3으로 산성화해야 합니다 . 그렇지 않을 경우 시스템 프로토콜이 불량한 결과를 산출합니다 .
	환기 관 아래에 끼이는 것을 방지하고 시료가 흐르는 것을 방지하기 위해 환기 관을 관 피팅의 중앙에 두십시오 .











PORTUGUÊS

Avisos	
	Este símbolo no instrumento indica que o usuário deve consultar o manual para obter instruções de operação.
	O sistema iOS e as portas de frascos contêm agulhas afiadas projetadas para perfurar as membranas dos frascos de amostra. Não coloque os dedos ou materiais impróprios no sistema IOS ou na porta de frasco.
	A água no sistema iOS pode estar quente. Antes de introduzir um frasco no sistema iOS, depois de operar no modo em linha, abra a porta e espere 30 segundos para que a amostra drene completamente. Introduzir um frasco antes da drenagem pode causar a pulverização de água quente lançada do sistema iOS.
	Este símbolo indica o terminal (terra) do analisador.
	Este símbolo indica que a Diretiva da União Europeia 2012/19/EU para resíduos de equipamentos elétricos e eletrônicos (REEE) requer que o analisador seja descartado separadamente do lixo comum.
	Para evitar choque potencialmente perigoso, antes de abrir o analisador, interrompa toda a análise e desligue o sistema operacional. Pressione o botão Power Off  no firmware do analisador, desligue o interruptor e desconecte-o da fonte de alimentação. Realizar qualquer operação que exija acesso ao interior do analisador sem desligá-lo, entre elas a instalação de itens de manutenção, poderá causar ferimentos.
	Para se proteger da exposição acidental à radiação ultravioleta, não opere a lâmpada UV fora de sua caixa de proteção. O compartimento da lâmpada UV pode estar quente. Tenha extremo cuidado sempre que tocá-lo.
	Aviso de Classe de risco 3: radiação UV emitida pelo produto. Evite a exposição dos olhos e da pele ao produto sem blindagem.
	A janela de vidro no reator UV indica a operação apropriada da lâmpada; não a olhe perto demais (menos de 15 cm) ou por períodos prolongados (mais de 1 minuto). Recomenda-se o uso de óculos de proteção.

Avisos

	Se este instrumento for usado de forma não especificada pela SUEZ, a proteção de segurança fornecida pelo instrumento poderá ser prejudicada.
	Para evitar ferimentos e para assegurar resultados exatos na análise, confirme que a porta do analisador está fechada e trancada durante a operação normal.
	Para assegurar a operação segura do instrumento, o aterramento da rede de CA deve estar seguramente conectado ao compartimento.
	Sempre interrompa a análise antes de desligar o analisador.
	Este produto está classificado como Segurança Classe I. Ele deve ser conectado a uma fonte de energia aterrada. Para evitar danos no analisador e a possibilidade de ferimentos, verifique se o aparelho está conectado a uma linha de energia com voltagem adequada.
	Este é um produto Classe A. Em ambiente doméstico, o produto pode causar interferência eletromagnética. Tome as medidas adequadas para corrigir o problema.
	Consulte a MSDS (Ficha Técnica de Segurança de Materiais) que acompanha cada conjunto de padrões para identificar as técnicas de descarte adequada.
	Para evitar choque potencialmente perigoso, não toque em nada dentro do analisador enquanto examina a bomba de amostras.
	Tome muito cuidado para evitar molhar componentes elétricos quando executar o procedimento.
	A lâmpada UV contém mercúrio e pode ser considerada material perigoso na sua área. Descarte esses itens de acordo com as normas dos governos federal, estadual e local.
	Se a lâmpada UV quebrar ou for danificada, manuseie os vestígios de acordo com o procedimento de manipulação de resíduos tóxicos da organização e os descarte de acordo com as regulamentações do governo federal, estadual ou local.

Avisos

	A diretiva WEEE 2012/19/EU se aplica às baterias e requer a remoção e coleta separada das mesmas. Depois de removidas, as baterias usadas são regidas pela diretiva para baterias 2006/66/EC e suas emendas. Descarte as baterias usadas de acordo com as instruções do fabricante e com os requisitos locais para eliminá-las/coletá-las.
	A operação do analisador sem filtro em linha na entrada de amostras danificará o analisador e cancelará a garantia. Para evitar danificar o analisador, instale o filtro e substitua o elemento de filtro quando necessário.
	Certifique-se de que o reservatório de água deionizada está cheio, especialmente, quando analisar amostras com TOC elevado ou concentrações altas de sal. Depois de analisar amostras com teor de sal ou TOC elevado, enxágue sempre o analisador operando um ciclo de amostra com água deionizada com TOC baixo.
	Consulte o Manual de operação e manutenção do analisador para obter instruções para encher o reservatório de água deionizada.
	Para evitar danos à bomba de água deionizada, verifique se o reservatório de água deionizada está cheio antes de ligar o analisador.
	Para evitar leituras de TOC falsas e possíveis danos ao analisador, verifique sempre se a entrada de amostras está aberta e se o reservatório de água deionizada está cheio antes de ligar o analisador.
	Feche sempre a porta do sistema iOS quando não realizar análises de amostras em frascos.
	Para proteger o aparelho de danos, sempre drene a água do analisador antes de qualquer envio.
	Quando limpar o analisador, aplique sempre o líquido no pano e NÃO pulverize líquidos diretamente no analisador. Não use água ou líquidos de limpeza na tela touchscreen, pois a água pode danificar ou descolorir o polarizador. Consulte a seção a seguir para obter recomendações para limpar a tela touchscreen. Limpe qualquer condensação imediatamente.
	Operar o analisador no modo em linha sem fluxo de amostras e com o sensor de fluxo desativado poderá causar medidas errôneas.

Avisos



Os padrões para o analisador de TOC on-line Sievers M500 são acidificados. Se preparar os seus próprios padrões e usar frascos de vidro, garanta acidificar os padrões com pH igual a 3, ou os protocolos do sistema produzirão resultados ineficientes.



Tenha certeza de centralizar o tubo de ventilação nos encaixes da tubulação para evitar pinçamento abaixo do tubo de ventilação que impeça o fluxo de amostras.

警告	
	仪器上的此符号表示用户应参阅操作说明手册。
	iOS 系统和样瓶端口装有用于刺穿样瓶垫片的尖利的针。请勿将手指或不当物体放入 iOS 系统或样瓶端口。
	iOS 系统中的水可能会很热。在在线模式下，在将样瓶插入 iOS 系统之前，应将分析仪的门滑开，等待 30 秒，使样品完全排空。如果在排空样品之前插入样瓶，热水会从 iOS 系统向上喷出。
	此符号表示分析仪的保护性接地端（地线）。
	此符号表示符合有关废弃电气和电子设备（WEEE）的欧盟指令 2012/19/EU，分析仪应与标准废物分开单独处置。
	为避免潜在的危險电击，在打开分析仪机箱之前，请先停止分析，关闭操作系统的电源开关。请按下分析仪固件中的“关闭电源（Power Off  ）”键，然后关闭电源开关，断开电源线连接。如果在不切断电源的情况下在分析仪内部进行操作（包括安装维护部件），都可能导致人员受伤。
	为了防止人员意外接触紫外线辐射，请勿在保护罩之外操作紫外灯。紫外灯罩可能很热。在碰触紫外灯罩时，请格外小心。
	第 3 组风险警告：本产品释放紫外线。请避免眼睛和皮肤接触无紫外线屏蔽的产品。
	紫外反应器的玻璃窗会显示紫外灯正常工作，观察时请勿靠得太近（小于 6 英寸距离）或时间太长（多于 1 分钟）。观察时建议佩戴防护眼镜。
	如果仪器未以 SUEZ 公司规定的方法使用，该仪器所提供的保护功能可能会被减弱。
	为避免人员受伤，并保证分析结果准确无误，请务必在正常操作期间关闭分析仪的机箱门，并将门锁紧。

警告

	为保证仪器安全工作，必须将交流电源接地线牢固地连接到机壳上。
	在关闭分析仪的电源开关之前，请先停止分析。
	这是安全等级 I 类产品。必须将分析仪连接到接地电源。为避免损坏分析仪，或造成人员伤害，请确保将分析仪连接到正确电压的电源线上。
	本产品是 A 级产品。在室内环境中，本产品可能产生电磁干扰，此时用户需要采取适当措施来消除干扰。
	请查阅每个标样组随附的化学品安全技术说明书（MSDS），确定正确的标样处置方法。
	为避免潜在的危险电击，在目视检查过程中观察样品泵时，请勿触碰分析仪内部的任何部件。
	执行此程序时，请格外小心，不可弄湿电气组件。
	紫外灯中含有汞，可能在您所在地区被认为是有害物质。请按照联邦、州或地方管理机构的规定来处置这些物品。
	如果紫外灯破损，应根据您所在组织机构的有毒废料处理程序以及国家、州 / 省或地方政府的相关规定进行处理。
	“WEEE 指令 2012/19/EU”适用于电池，要求将电池取出并单独收集。取出废旧电池后，请按照“电池指令 2006/66/EC 及其修正文件”的规定来处理。请按照制造商的说明和您所在地对废旧电池的处置和收集要求来操作。
	在操作分析仪时，如果进样管上没有装管内过滤器，将会损坏分析仪，并使仪器的保修失效。为避免损坏分析仪，请安装过滤器，并按需要及时更换滤芯。
	确保去离子水容器已灌满水，尤其是在运行高 TOC 或高盐浓度的样品时。运行高 TOC 或高盐样品之后，请务必运行低 TOC 的去离子水一个样品周期，以冲洗分析仪。

警告



请按照分析仪的操作和维护手册中的指导来加注去离子水容器。



为了避免损坏去离子水泵，在启动分析仪之前，先确保去离子水容器已灌满水。



为避免 TOC 读数出错和损坏分析仪，在打开分析仪的电源开关之前，请确保打开样品进口，并注满水去离子水容器。



如果不从样品瓶取样，请始终关闭 iOS 系统的门。



为了避免损坏分析仪，请务必在运输前将分析仪中的水排干。



仪器上的此符号表示本产品含有“中国 RoHS II”管理办法中限制的物质。请参考下表。

M500 TOC Analyzer
产品中有害物质的名称及含量

Table of Hazardous Substances' Name and Concentration

部件名称 Component Name	有害物质Hazardous Substances' Name					
	铅 (Pb)	汞 (Hg)	镉 (Cd)	六价铬 (Cr(VI))	多溴联苯 (PBB)	多溴二苯醚 (PBDE)
紫外灯 - UV Lamp	O	X	O	O	O	O

本表格依据SJ/T 11364的规定编制。
This table is prepared according to SJ/T 11364.

O: 表示该有害物质在该部件所有均质材料中的含量均在 GB/T 26572规定的限量要求以下
X: 表示该有害物质至少在该部件的某一均质材料中的含量超出 GB/T 26572规定的限量要求

- 此表所列数据为发布时所能获得的最佳信息





O: Indicates that hazardous substance contained in all of the homogeneous materials for this part is below the limit requirement in GB/T 26572.

X: Indicates that the hazardous substance contained in at least one of the homogeneous materials used for this part is above the limit requirement in GB/T 26572.

- Data listed in the table represents best information available at the time of publication.

请注意：本产品含有紫外线灯（含汞），符合“RoHS 指令 2011/65/EC”的附件 III 4（a）规定的豁免条件。

警告

	<p>在清洁分析仪时，应将清洁液放在抹布上，不可将清洁液直接喷洒在分析仪上。</p> <p>不可在触摸屏上使用水或清洁剂，水可以使偏振片损坏或褪色。请参阅后面的章节了解触摸屏的清洁方法。</p> <p>应立即擦去触摸屏上的冷凝水。</p>
	<p>在没有样品流量且流量传感器关闭的情况下，如果以在线模式运行分析仪，就会导致错误的测量结果。</p>
	<p>Siemens M500 在线型 TOC 分析仪的标样已被酸化。如果您自行制备标样并使用玻璃瓶，请确保将标样酸化至 pH 值为 3，否则系统任务会产生不准确的分析结果。</p>
	<p>请确保使排气管处于管接头内的中间位置，以防止夹住排气管下部，并阻碍样品流动。</p>

1

INTRODUCTION

.....

The Sievers M500 TOC Analyzer from SUEZ is a high-sensitivity Analyzer used to measure the concentration of total organic carbon (TOC), total inorganic carbon (TIC), and total carbon (TC = TOC + TIC) in water samples.

The Analyzer is based on the oxidation of organic compounds to form carbon dioxide (CO₂) using UV radiation. Carbon dioxide is measured using a sensitive, selective membrane-based conductometric detection technique. For each TOC measurement, the concentration of inorganic carbon species (CO₂, HCO₃⁻, and CO₃⁻²) is determined and, after oxidation of the organic compounds, the total carbon (TC) content of the sample is measured. The concentration of the organic compounds is then calculated from the difference between the concentrations of TC and total inorganic carbon (TIC), generally referred to simply as inorganic carbon (IC).

$$(TOC = TC - IC)$$

The Analyzer can be used to monitor water samples ranging from high-purity water containing <0.03 parts per billion (ppb) TOC to water samples containing up to 2.5 parts per million (ppm) TOC. The Analyzer is easy to operate, with extremely low maintenance, and no special training or chemical knowledge is required. The Analyzer is calibrated at the factory, and TOC calibration remains stable for approximately one year. For configurations with a Super iOS[®] or Standard iOS, re-calibration and validation can be easily performed at the customer site. In configurations with a Sample Inlet Block, rather than an iOS system, not all menu options may be relevant or available on the Analyzer.

This manual describes typical operational requirements and recommended procedures that are valid for most applications. Special conditions in operating environments may require modifications to the recommendations in this manual. Specific instructions provided by Technical Support or your local service provider supersede the information provided in this manual.

THIS PAGE IS INTENTIONALLY LEFT BLANK.

2

SYSTEM DESCRIPTION

SYSTEM SPECIFICATIONS

total organic carbon	
Linear Range	0.03 to 2,500 ppb as TOC
Accuracy	± 5% of measurement; ±0.1 ppb
Precision	± 1% of measurement; ± 0.03 ppb
Analysis Modes	Online, Online Averaged, Online Timed, Grab
Analysis Time ^{1, 2}	3 minutes for continuous online measurements
Ozone Compatibility	50 ppb O ₃ continuous; 200 ppb O ₃ for 2 hours daily
Sample Flow Rate (nominal)	0.25 mL/min
External Flow Rate	Minimum 50 mL/min
Sample Temperature	1-95 °C (34-203 °F) (withstands short-term steam exposure)
Sample Pressure	Up to 100 psig
Interferences	Insensitive to organic heteroatoms
Calibration Stability	Typically stable for 12 months
Display Readout	3 significant digits
conductivity	
Range	0.01 to 800 µS/cm
Accuracy	0.005 µS/cm or 1%, whichever is larger
Precision	≤ 1.0 % RSD
instrument	
Power Requirements	100–240 VAC, 70 W, 50/60 Hz
Fuses	No user-replaceable fuses
Normal Operating Environment	Intended for indoor use only
Ambient Temperature	5-40 °C (41-104 °F)
Maximum Relative Humidity	Up to 95%, noncondensing
Maximum Altitude	3,000 m (9,843 ft)
Inputs	Two isolated binary inputs
Outputs	Serial (RS-232), one USB, three 4-20 mA, four alarms, one Ethernet
Installation/Overtoltage Category	II (protects against transients present in Category II power)
Safety Certifications	CE, ETL listed. Conforms to UL Std. 61010-1. Certified to CSA 22.2 No. 61010-1.
Pollution Degree	2 (normally only non-conductive pollution)
Display	Backlit 10.1", 1280 x 800, touchscreen display
Size	H: 43.4 cm (17.1 in) W: 55.9 cm (22.0 in) D: 28.7 cm (11.3 in)
Weight	16.3 kg (36 lb)
IP Rating	IP 55
Optional Wi-Fi	802.11ac/a/b/g/n Dual band 2.4/5 GHz
Industrial Communication Protocols	Modbus TCP/IP & Profinet (Included), Profibus (Optional)

¹Time to first measurement is 10 minutes.

²Base model analysis time is six minutes for continuous online measurement.

SYSTEM OVERVIEW

The M500 TOC Analyzer consists of five major subsystems:

1. Sample inlet system and sample pump, including the Super Integrated Online Sampling (iOS) System or Standard iOS System.
2. Oxidation reactor
3. Measurement module, comprising:
 - CO₂ transfer manifold
 - Sample conductivity cell
4. Fluidics module, comprising:
 - DI (Deionized) water reservoir (including resin cartridge)
 - DI water pump
5. Electronics subsystems, comprising:
 - Microprocessors and circuit boards
 - Data outputs

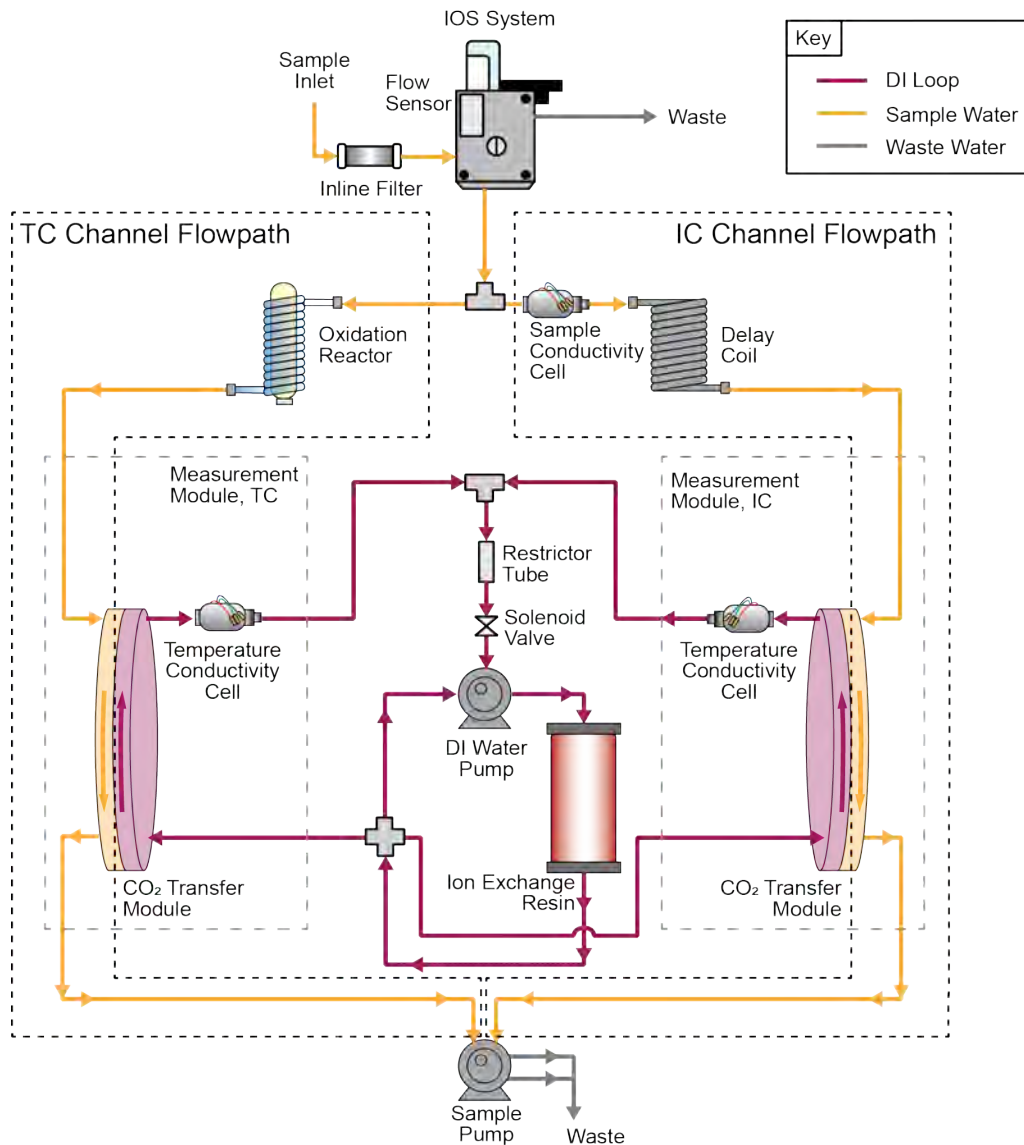

Figure 1: Analyzer Schematic (Shown with Standard iOS)

SAMPLE FLOW PATH

The Sievers M500 TOC Analyzer is available in three primary configurations: with the Super iOS, offering four vial ports and online monitoring; with the standard iOS, offering one vial port and online monitoring; and with the Sample Inlet Block, offering online monitoring only.

Discrete samples can be measured by the M500 TOC Analyzer by inserting a filled 40 mL sample vial into the iOS System. Continuous monitoring is accomplished by plumbing a sample line to the inlet of the iOS System or the Sample Inlet Block. The stream splitter divides the sample stream into two equal but separate flows. One stream

is processed for the measurement of IC. The other is processed for measurement of TC.

The TC stream passes to an oxidation reactor where the sample is exposed to UV light, which oxidizes the organic compounds in the sample, converting them to CO₂. The reactor is a spiral quartz tube wrapped around the UV lamp. The UV lamp emits light at 185 and 254 nm resulting in the formation of powerful chemical oxidizing agent in the form of hydroxyl radicals produced by the photolysis of water (eq. 1):

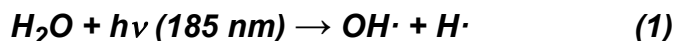

The hydroxyl radicals (OH·) will completely oxidize organic compounds, converting the carbon atoms of the organic compound into CO₂.



The IC stream passes through a delay coil, which is designed to make the total transit time of the IC stream through the Analyzer the same as the transit time of the TC stream through the Analyzer.

When the TC stream exits the oxidation reactor and the IC stream exits the delay coil, each stream moves to the CO₂ transfer manifold. The CO₂ transfer manifold is a patented design, utilizing a gas-permeable membrane that allows the transfer of CO₂ across the membrane. The membrane separates the sample side of the Analyzer from the DI side. The DI side of the Analyzer is a closed loop, and consists of two conductivity cells—one for the TC stream and one for the IC stream, a DI water pump, a DI water reservoir, and an ion exchange resin cartridge.

CO₂ from the sample passes through the membrane into the DI water supplied by the integrated DI Loop, while interfering compounds and other oxidation by-products are blocked by the membrane and remain on the sample side. The CO₂ forms carbonic acid upon reaction with water, and the carbonic acid disassociates into hydrogen ions and bicarbonate ions:

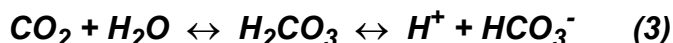

DI water is continuously pumped through the DI side of the Analyzer, collecting the H⁺ and HCO₃⁻ ions and H₂CO₃ and CO₂ molecules from the CO₂ transfer modules, delivering it to the conductivity cell for measurement. The ion exchange resin then removes the HCO₃⁻ and H⁺. The water is then pumped back to the CO₂ transfer module to repeat the sequence.

The TC and IC conductivity cells each contain a thermistor, and all conductivity readings are temperature corrected. The CO₂ from the TC and IC sample streams are measured by the respective conductivity cells, and the conductivity readings are used to calculate the concentration of TC and IC. After the values are measured, TOC is calculated as the difference:

$$TOC = TC - IC \quad (4)$$

ADDITIONAL SYSTEM COMPONENTS

Microprocessor Controller and Electronics

The M500 TOC Analyzer contains eight proprietary electronic board assemblies which monitor and control Analyzer functions:

- System board including a system on module CPU with ARM microprocessor, 4 GB memory, 1 GB DDR RAM, non-volatile flash memory for operator settings, digital input/output (I/O), display graphics controller, RS-232 (serial) port, interface-to-USB storage devices, Ethernet port, and WiFi (optional).
- Fan controller which controls three fans, one for thermal control, within the Analyzer
- Passive interconnect board
- Instrument controller I/O board with interfaces to pumps and motors, UV lamp, external devices, via binary input, four alarms, and three 4-20 mA outputs
- LED capacitive touch panel display and interface
- Analog to digital conversion boards (2) with integrated signal conditioning circuits for cell conductivity and temperature measurements
- Sample port valve (4) control on the Super iOS

DATA OUTPUTS

The Sievers M500 TOC Analyzer offers three 4-20 mA outputs, four alarm outputs, and two isolated binary (start/stop) inputs. The Analyzer also includes one serial (RS-232), one USB, and one Ethernet output allowing flexibility for exporting and printing data. Real-time and historical data can be transferred from the Analyzer via Ethernet (using a communications software, such as Modbus or ProfiNet) or from the serial port to a computer (using a communication software such as PuTTY. The Analyzer also enables the use of a communications software (such as PuTTY) to issue commands to the Analyzer via a serial (RS-232) or Ethernet connection. (For more information, see [“Streaming Data” on page 433.](#))



NOTE: *The Analyzer’s USB port is designed for connection to a USB memory device. The USB port does not support connectivity to a computer or printer.*

THIS PAGE IS INTENTIONALLY LEFT BLANK.

3

INSTALLATION

OVERVIEW

This chapter provides installation instructions for the Sievers M500 TOC Analyzer. An overview image of the interior of the Analyzer is provided in [Figure 2](#). For additional assistance, contact Technical Support or your local service provider. Installation and training by a qualified service technician are also available.

Warning



To avoid potentially dangerous shock, BEFORE opening the Analyzer, stop any analysis and power off the operating system. Press the Power On/Off  button in the Analyzer's firmware, then turn off the power switch and disconnect from the power supply. Any operation requiring access to the inside of the Analyzer without turning off power, including installation of maintenance items, could result in injury. The exceptions include the activities conducted during the Instrument Startup Wizard (including filling the DI Reservoir) where the Analyzer detects no flow and does not turn on the DI Pump. Ensure power is off before filling the DI Reservoir during subsequent routine maintenance.

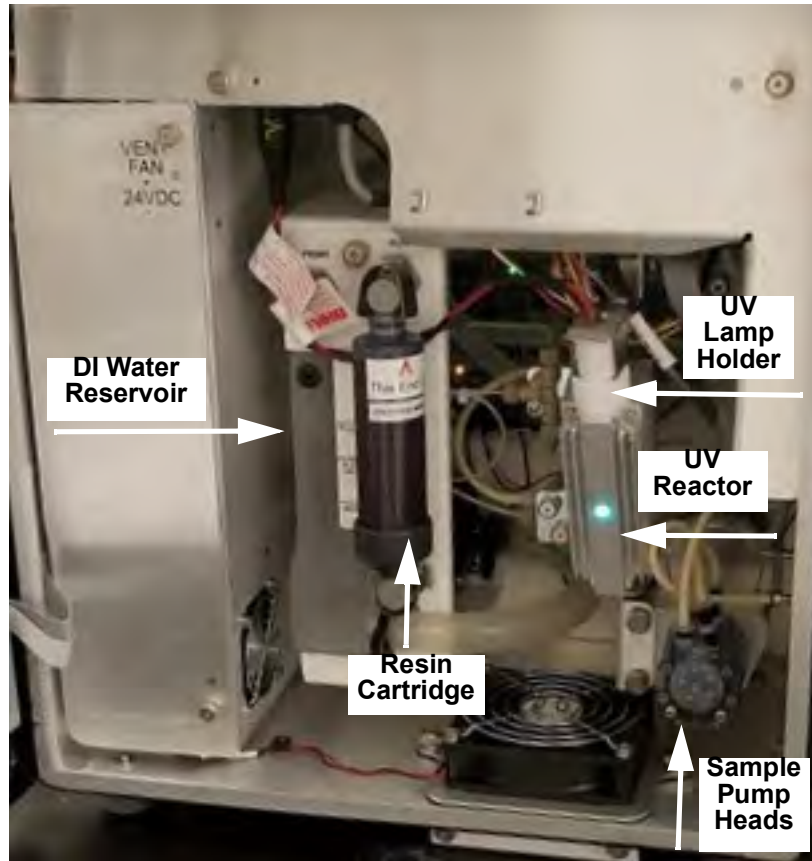

Figure 2: Interior Overview of the Analyzer

STEP 1: UNPACK AND INSPECT THE ANALYZER

Unpack the shipping carton(s) and verify that the shipment contains all the contents shown in the following [Packing List](#) section.



NOTE: Always save original packing materials! If for any reason the Analyzer needs to be returned, it must be packed in the original carton to ensure that no damage occurs during shipment. For cases when the original packaging is no longer available, SUEZ-replacement packaging is required for a return shipments and a charge is assessed for this new packaging. Insure the Analyzer for the return shipment.

Packing List

- Sievers M500 TOC Analyzer
- Certificate of Calibration

- *Sievers M500 TOC Analyzer Quick Start Guide*



NOTE: *The Sievers M500 TOC Analyzer Operation and Maintenance Manual and Sievers M500 TOC Analyzer Qualification Package — IQ/OQ Volume are available for download from our website.*

- (Optional) DataGuard Activation Code
- Accessories kit:
 - Resin cartridge assembly
 - Calibration resistor
 - Sample inlet tubing (1/4") with in-line filter (60 micron)
 - PFA tubing assembly (1/16" OD x 04" ID x 30" L)
 - Worm-drive hose clamp (25/32")
 - Connector, male metric conversion, for use with 1/4" to 6 mm tubing
 - PVC tubing (1/2" ID, 3/4" OD, clear) for waste line
 - Polypropylene tubing (1/4" OD x 1/8" ID)
 - Open-end wrench, (9/16")
 - Screwdriver (four blades)
 - Water bottle (250 ml/8.5 ou.) with nozzle, for filling DI water reservoir
 - Grounding strap
 - Terminal ring (M4 #8)
 - USB memory device
 - Keys (2) for the bottom latch on the Analyzer

Additional Installation Equipment

To install the Sievers M500 TOC Analyzer, the following user-supplied equipment is also required:

- Mounting hardware to support the Analyzer (See "[Step 3: Select a Location for the Analyzer](#)" on page 64.)
- Insulated wire (18-12 AWG, rated to 300 Volts) for AC power conduit (See "[Installing the AC Conduit](#)" on page 72.)
- An external circuit breaker or switch that disconnects both poles of the supply voltage, rated 2-5A
- (Optional) Insulated wire, 16-26 AWG, rated to 300 Volts for wiring I/O terminal blocks (See "[Installing I/O Wiring](#)" on page 65.)
- (Optional) Analog (4-20 mA) recorder

- (Optional) Ethernet cable

STEP 2: COMPLETE THE IDENTIFICATION RECORDS

Complete the section, [“Identification Records” on page 3](#) by recording the date of receipt and the Analyzer serial number (located on the left side of the Analyzer).

STEP 3: SELECT A LOCATION FOR THE ANALYZER

The Sievers M500 TOC Analyzer is designed to be mounted on a wall or support stand. The Analyzer has pre-installed mounts that create a minimum 2.5 cm clearance from a wall for heat dissipation. Allow a minimum 30.5 cm of clearance on the sides, top, and bottom of the Analyzer for the plumbing and electrical connections. Additionally, this clearance provides proper circulation for temperature and humidity control.

When selecting the location, mount the Analyzer so that the display screen is approximately at eye-level. Diagrams showing Analyzer dimensions and clearances are provided in [Appendix A, “Analyzer Dimensions.”](#)

Select and procure hardware for mounting the Analyzer on a wall or instrument rack, based on site-specific circumstances. Mounting hardware must be able to support four times the weight of the unit [65.2 kg (144 lbs) for unit with Super iOS; 54.4 kg (120 lbs) for unit with standard iOS].

Avoid direct sunlight and extreme temperatures. Operating at elevated temperatures greater than 40 °C (104 °F) prevents proper operation and operating at temperatures lower than 5 °C (41 °F), can cause errors in the measurements. The Sievers M500 TOC Analyzer withstands the hazards of industrial process environments, and the Analyzer enclosure is rated IP 55.

STEP 4: INSTALL I/O CONTROL WIRING (OPTIONAL)

The Sievers M500 TOC Analyzer offers three 4-20 mA outputs, four alarm outputs, and two isolated binary inputs via the four terminal blocks on the instrument controller board (located inside and at the top of the Analyzer). The following terminal block positions are pictured in step [6](#) of the [“To install I/O wiring” on page 65](#).

- J1 — Alarm Relay Outputs
- J2 — Isolated State Inputs
- J3 — Isolated State Outputs (This terminal is not used. Do **not** make any connections to this terminal block.)
- J4 — 4-20 mA Analog Current Loop

This section includes step-by-step instructions for [“Installing I/O Wiring” on page 65](#). Additional information to assist in the installation is also provided:

- [“Working with Alarm Outputs \(J1\)” on page 68](#)
- [“Working with 4-20 mA Analog \(J4\) Outputs” on page 69](#)
- [“Working with Binary Inputs \(Remote Start/Stop\) \(J2\)” on page 70](#)

After installing I/O control wiring, configure the analog and alarm settings, and activate the binary input, in the Analyzer’s firmware later in [" Step 9: Configure Basic Analyzer Settings" on page 89.](#)

Installing I/O Wiring

Use this instruction to install the following on the I/O instrument controller board, as needed:

- 4-20 mA output connection
- Alarm output connections
- Binary (start/stop) input connections

To install I/O wiring

The wire should be 16-26 AWG, rated to 300 V. The strip length for each pin should be 8-9 mm (0.33 in).

1. Ensure to exercise ESD protection while working inside the Analyzer.
2. Unlock and push the release button to unlatch and open the door to the Analyzer.
3. Remove the following covers (Turn the fasteners 1/4 turn to release.):
 - AC Power cover **(A)**, located on the left side of the Analyzer
 - I/O Control wiring cover **(B)**, located at the top of the Analyzer

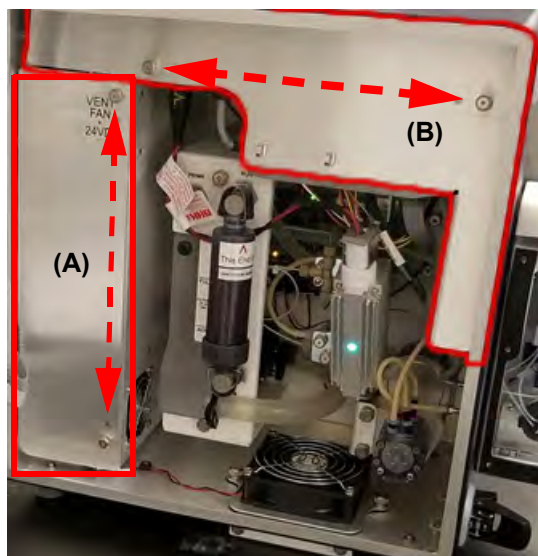

Chapter 3 INSTALLATION

4. Locate the I/O instrument controller board (C) and wire glands (D) inside the Analyzer.

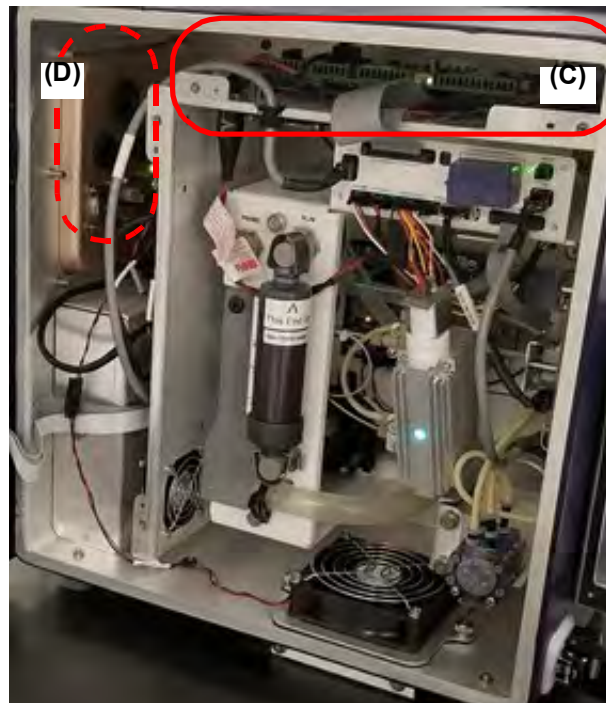

5. Route the I/O wires into the instrument through the wire glands from the outside I/O panel, located on the left side of the Analyzer. A view of the I/O panel is provided, identifying typical wire gland use at (E) and (F):

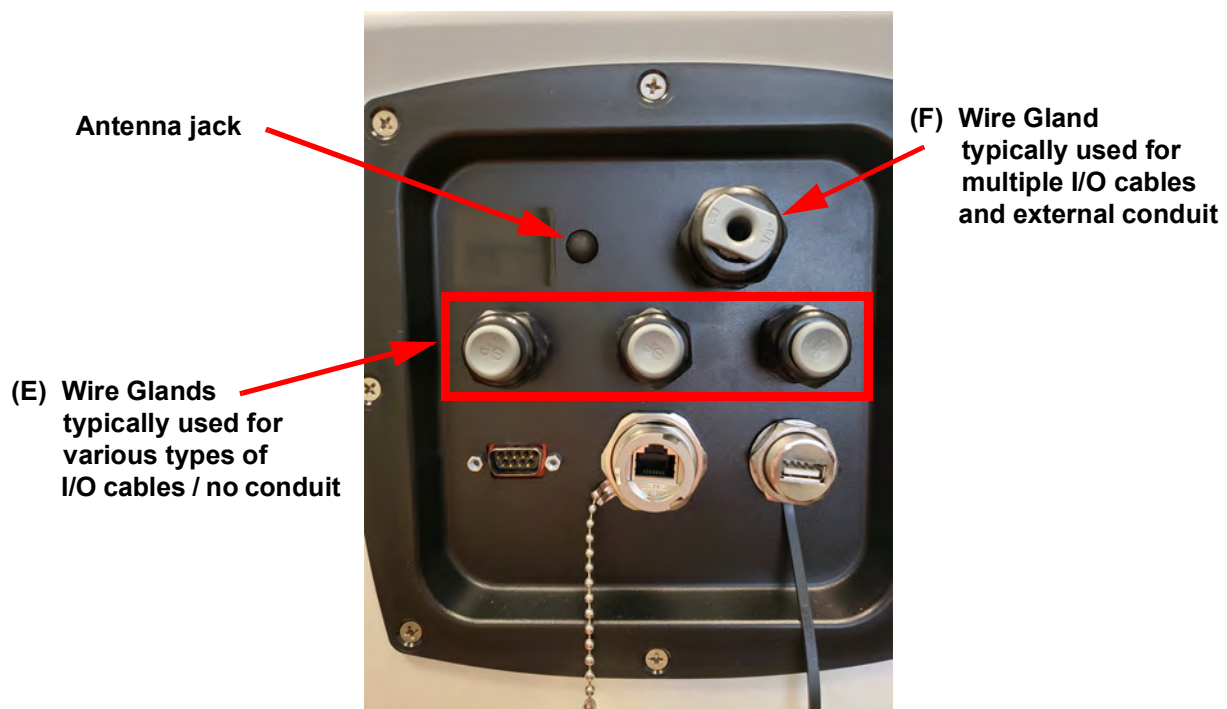



(E) Three smaller I/O glands (left-to-right)

- One to three 4-20 mA analog pairs, or a single multiple conduct cable
- One or two isolated state inputs cable(s)
- One alarm relay output

(F) One larger I/O gland

Multiple I/O cable bundled together and routed out of the box into conduit

6. Identify the corresponding terminal block to use for each type of I/O output or input wire installation:

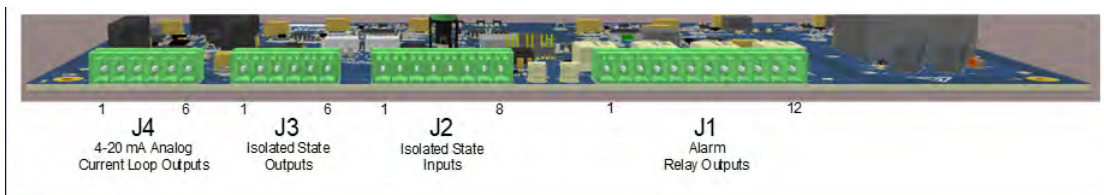

7. To install the wires in a terminal block, first remove the corresponding terminal block from the I/O instrument controller board. Make a note of the terminal block's orientation of Pin #1 before removing it. Firmly grasp the terminal block and pull it straight out from the terminal header on the board.
8. Identify the correct pin position for each wire to install according to [Table 2, "4-20 mA Analog Outputs \(J4\)," on page 69](#) or [Table 1, "Alarm Relay Outputs \(J1\)," on page 68](#) or [Table 3, "Isolated State Inputs \(J2\)," on page 70](#).
9. To attach each wire, use the small flat blade of the screwdriver to depress the orange tab (example shown at the arrow) while inserting the stripped wire into the hole, and then release the tab to secure. The wire should remain captured in the hole.

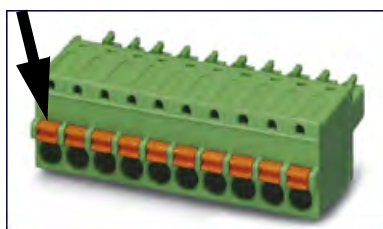

For additional wiring information, refer to the following sections, as needed:

- 4-20 mA Analog Current Loop Outputs — [Table 3, "Alarm Relay Output Detail," on page 69](#) and ["Figure 4: Typical 4-20 mA Circuit Applications" on page 70](#).
- Alarm Relay Outputs — [Table 1, "Alarm Relay Outputs \(J1\)," on page 68](#) and [Figure 3: Alarm Relay Output Detail on page 69](#).
- Binary (Start/Stop) Inputs — [Table 3, "Isolated State Inputs \(J2\)," on page 70](#) and [Figure 5: Isolated State Input Circuit Detail on page 71](#) and

[Figure 6: Instrument-Powered Isolated State Input Circuit Application on page 71.](#)

10. Repeat steps [6](#) through [9](#) for each terminal block to install.
11. Gently pull on each connection to make sure the connection is secure.
12. Plug the terminal block into the terminal header on the instrument controller board.
13. Repeat steps [6](#) through [12](#) for each I/O Output or Input installation.
14. If planning to install the power now, leave the covers off and go to step [“Step 5: Install Power” on page 72.](#) Or, if continuing the installation process at a later time, replace the following covers (push and turn the fasteners 1/4 turn to secure):
 - Electrical cover **(A)**, located on the left side of the Analyzer
 - I/O Control wiring cover **(B)**, located at the top of the Analyzer
15. Close and latch the Analyzer’s door.

Working with Alarm Outputs (J1)

Refer to the following pin-out information ([Table 1](#)) and relay output details ([Figure 3](#)) when installing alarm output wiring.

Table 1: Alarm Relay Outputs (J1)

<i>Pin Number</i>	<i>Signal</i>	<i>Function</i>
1	ALARM_1_NC	Relay 1 Normally Closed contact
2	ALARM_1_COM	Relay 1 Common contact
3	ALARM_1_NO	Relay 1 Normally Open contact
4	ALARM_2_NC	Relay 2 Normally Closed contact
5	ALARM_2_COM	Relay 2 Normally Common contact
6	ALARM_2_NO	Relay 2 Normally Open contact
7	ALARM_3_NC	Relay 3 Normally Closed contact
8	ALARM_3_COM	Relay 3 Normally Common contact
9	ALARM_3_NO	Relay 3 Normally Open contact
10	ALARM_4_NC	Relay 4 Normally Closed contact
11	ALARM_4_COM	Relay 4 Normally Common contact
12	ALARM_4_NO	Relay 4 Normally Open contact



NC = normally closed, NO = normally open

Nominal switching power: 1A 30 VDC, 0.5A 125 VAC (resistive load)

Break-Before-Make operation

ISOLATION LEVELS:

- Insulation resistance: Min. 1,000 MΩ @500 VDC
- Breakdown voltage:
 - Between open contacts:750 Vrms for 1 min. (Detection current: 10 mA)
 - Between contact and coil 1,000 Vrms for 1 min. (Detection current: 10 mA)
 - Between contact sets 1,000 Vrms for 1 min. (Detection current: 10 mA)

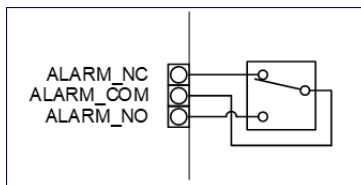

Figure 3: Alarm Relay Output Detail

Working with 4-20 mA Analog (J4) Outputs

The data from the Analyzer can be recorded using the 4-20 mA outputs located on the J4 terminal block. Refer to the following pin-out information ([Table 2.](#)) and typical circuit applications ([Figure 4.](#)) when installing 4-20 mA Analog output wiring.

Table 2: 4-20 mA Analog Outputs (J4)

Pin Number	Function
1	#1 4-20 mA (Return) -
2	#1 4-20 mA (Out) +
3	#2 4-20 mA (Return) -
4	#2 4-20 mA (Out) +
5	#3 4-20 mA (Return) -
6	#3 4-20 mA (Out) +

Instrument Powered Loop Output

Nominal Operating Range: 4-20 mA

Current Calibration Adjustment Range: 0-24 mA

Alarm Indication (option): 22 mA

Maximum Loop Resistance: 600 Ohms

ISOLATION LEVELS:

This interface does not provide safety barrier isolation. The isolation is low voltage and intended to isolate the instrument DC power from the customer's power supplies only:

Chapter 3 INSTALLATION

- 1000 V for 1 second
- Operation rating: SELV limits < 42.5V peak, or 60 VDC

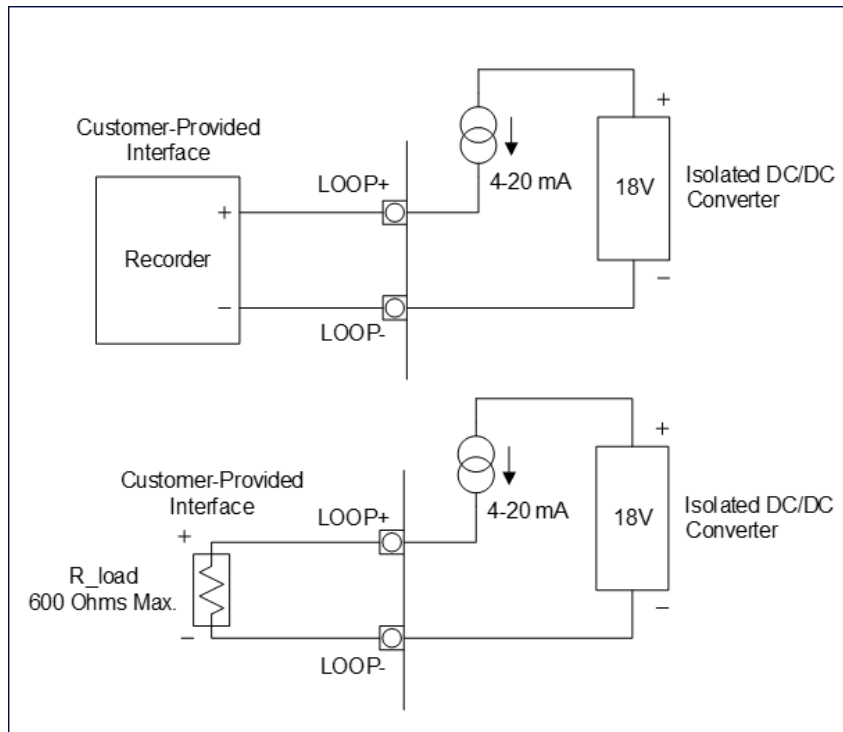

Figure 4: Typical 4-20 mA Circuit Applications

Working with Binary Inputs (Remote Start/Stop) (J2)

The Sievers M500 TOC Analyzer has two isolated binary inputs. These can be wired in a variety of ways and are intended to execute a start/stop commands to the Analyzer from a remote location, such as a Process Logic Control (PLC) System or Center. Pin-out details are included in [Table 3](#). Wiring examples are shown in "[Figure 5: Isolated State Input Circuit Detail](#)" on page 71 and "[Figure 6: Instrument-Powered Isolated State Input Circuit Application](#)" on page 71.

Activate the binary input in the Analyzer firmware later in "[Step 9: Configure Basic Analyzer Settings](#)" on page 89. To avoid unexpectedly starting or stopping analysis, it is important to confirm the correct signal strength before configuring binary settings. For more information on activating binary input, see "[To set the binary input](#)" on page 110.

Table 3: Isolated State Inputs (J2)

Pin Number	Signal	Function	Application
1	+24V	Non-isolated +24VDC	
2	BININ1+	Isolated input 1	START+



Table 3: Isolated State Inputs (J2)

Pin Number	Signal	Function	Application
3	BININ1-	Isolated input 1	START-
4	BININ2+	Isolated input 2	FLOW_SENSE+
5	BININ2-	Isolated input 2	FLOW_SENSE-
6	(reserved)	No connection	-
7	(reserved)	No connection	-
8	GND	Non-isolated DC Common	

BININ+ to BININ- Voltage Range: +12 to +28 VDC

Inputs are reverse polarity protected to 40 V

ISOLATION LEVELS:

- UL1577, 4, 170 VAC rms for 1 minute
- DIN-EN/IEC60747-5-5, 850 V peak insulation working voltage

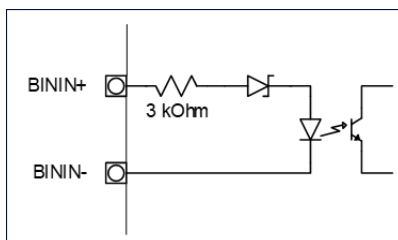

Figure 5: Isolated State Input Circuit Detail

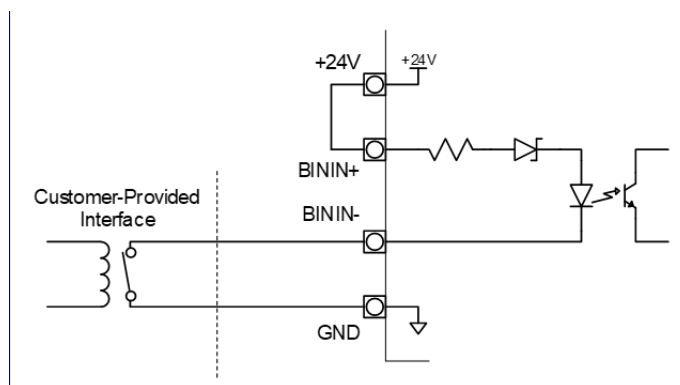

Figure 6: Instrument-Powered Isolated State Input Circuit Application

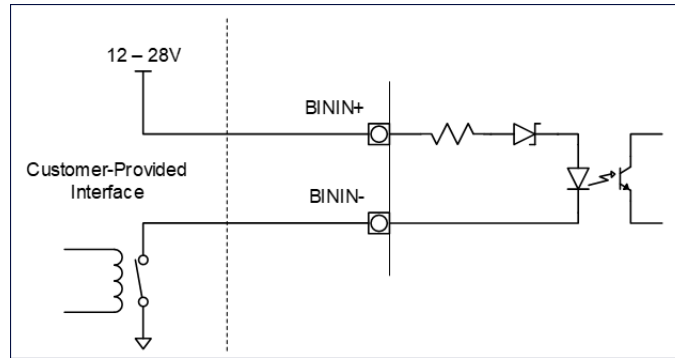

Figure 7: Externally-Powered Isolated State Input Circuit Application

STEP 5: INSTALL POWER

This section contains information about how to install power to the Analyzer.

Installing the AC Conduit

The Sievers M500 TOC Analyzer requires the installation of conduit to provide an external source of AC power, which is connected to the enclosure using a water-tight conduit connector. This type of electrical connection should be performed by a qualified electrician.

SUEZ recommends an external switch or circuit breaker (rated 2-5A) to facilitate maintenance and servicing of the Analyzer. Install it near the Analyzer and clearly mark it as the disconnecting device for the Analyzer.

To wire the AC conduit

Provide the following for this procedure:

- Insulated wire for AC power conduit (18-12 AWG), rated to 300 Volts (Strip length should be 8-9 mm (0.33 in.)
- (Optional) Metallic AC power conduit¹ [Alternatively, a PVC conduit connector (strain relief hub) and sealing washer is provided in the Accessories Kit.]
- Terminal ring (M4 / #8) for AC conduit ground wire (18-12 AWG), provided in Accessories kit (If using wire of a different gauge, an appropriate terminal ring is needed.)
- Recommended external circuit breaker or switch that disconnects both poles of the supply voltage, rated 2-5A

1. Ensure to exercise ESD protection while working inside the Analyzer.



2. If needed, unlock and push the release button to unlatch and open the door to the Analyzer.
3. If previously replaced, remove the electrical cover (located on the left side of the bulkhead). Turn the fasteners 1/4 turn to release.

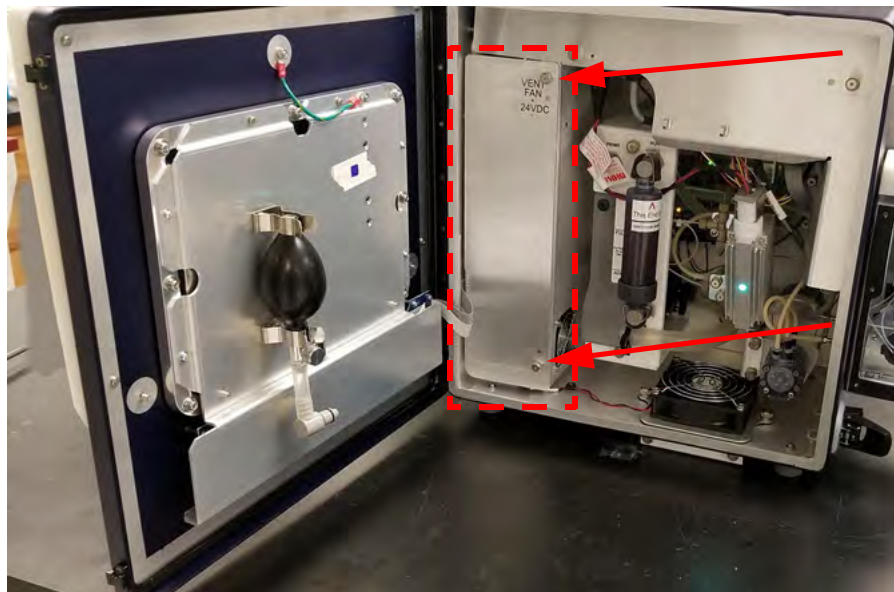

4. Pull the AC line cable through the AC mains wire gland on the enclosure.

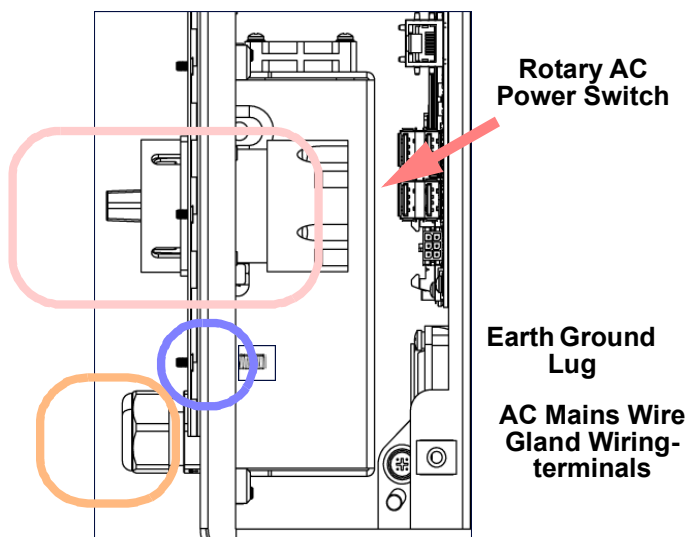
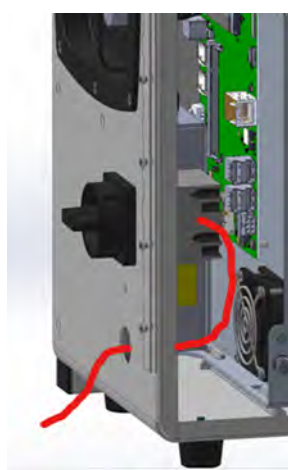

5. Strip back the cable sheath on the individual wires by about 3½ inches and crimp a ring terminal lug (for M4 or #8 stud) onto the earth-lead ground conductor.

Chapter 3 INSTALLATION

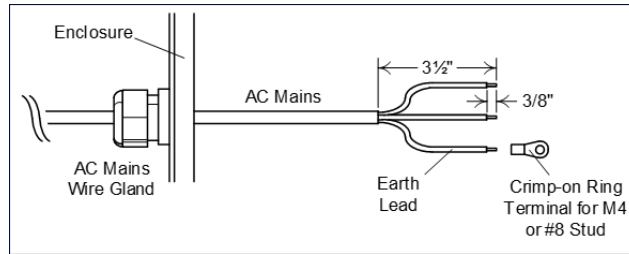

6. Locate the terminal block on the back of the rotary power switch inside the power supply area of the Analyzer.



7. Connect the AC main wires to the front (the side facing the user) of the terminal block on the rotary AC power switch, as follows:
 - Connect the *Line* (brown or black wire, typically) wire to the front of the Terminal block in terminal #5.
 - Connect the *Neutral* (blue or white wire, typically) in terminal #4.

When connecting each wire to the terminal block, loosen the screws (at the location shown with the arrows) and insert the wires as designated. Tighten the screws to secure the wires.

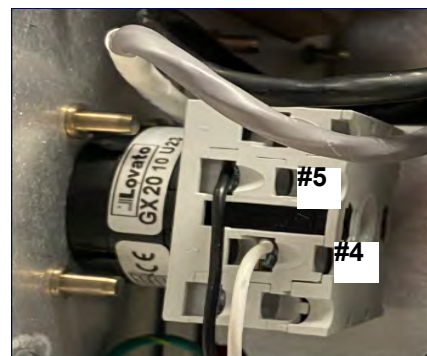
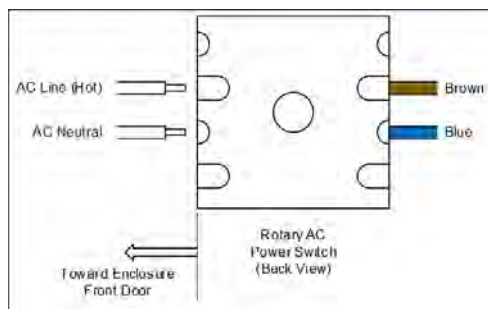

8. After connecting the wires, pull on each connection gently to make sure the connection is secure.
9. Attach the AC mains earth ground wire to the grounding lug.

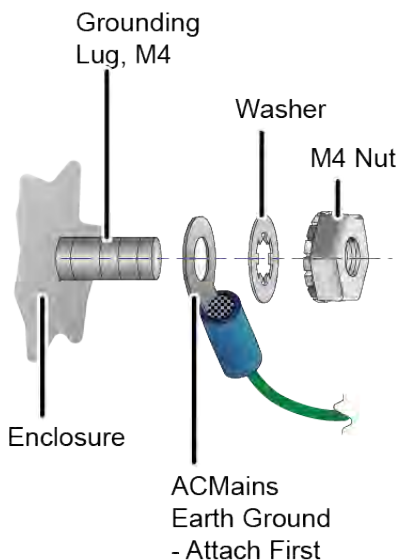

Warning



To assure safe operation of the instrument, the AC Mains Earth Ground must be securely connected to the enclosure.

10. Attach the power supply chassis ground wire.
11. Secure both wires to grounding lug with an M4 nut.
12. Replace the electrical cover and turn the fasteners 1/4 turn to secure.
13. Close and latch the door to the Analyzer. (Lock the latch, if required for the user's location.)

STEP 6: CONNECT THE SAMPLE INLET AND OUTLET PORTS

The Analyzer is designed to measure water from a continuous sample flow in *Online* mode. The iOS System or Super iOS System can be used to sample from vials when the Analyzer is operated in *Grab* mode. When taking measurements from vials (for example, for calibration and verification of the Analyzer), no plumbing change is required. The 40-mL vials are simply inserted into the iOS System or Super iOS System.

Cautions

To avoid false TOC readings and possible damage to the Analyzer, always make sure the sample inlet is open and the DI water reservoir is filled **before** turning on the Analyzer. Always close the door of the iOS System when not sampling from a vial.

Operation of the Analyzer without the in-line filter on the sample inlet line will damage the Analyzer and void the warranty. To avoid damaging the Analyzer, install the filter and replace the filter element as needed.

Configuring the sample inlet and outlet ports

Disable the flow from the water source until the sample inlet system is completely installed and the Analyzer is ready to begin analysis.

To configure the sample inlet and outlet ports

1. Connect the 1/4" Teflon[®] tubing with the in-line filter to the sample inlet on the iOS or Super iOS System or the Sample Inlet Block, depending on the Analyzer's configuration. Tighten 1/4 turn past finger-tight with a 9/16" open-end wrench. Do not over-tighten the nut.
2. Connect the 3/4" OD waste line tubing to the waste outlet on the sample inlet system or the Sample Inlet Block by sliding the tubing over the barb fitting.
3. Place the hose clamp over the waste line and tighten, to secure the connection to the waste outlet.
4. Route the waste tubing to an appropriate waste outlet. The waste is gravity-drained, and thus the waste tubing cannot be routed above the level of the waste from the waste line to between 50-300 mL/min. The flow rate is controlled by a needle valve, which is adjusted by the screw on the sample inlet system. Turn the screw clockwise to decrease flow and counter-clockwise to increase flow.



NOTE: Avoid setting a water flow rate that exceeds 300 mL/min, which may result in poor system suitability verification data. Excessive flow also prevents the sample pump from properly drawing sample.



STEP 7: INSTALL THE DI WATER SYSTEM

Install the calibration resistor and then use the Analyzer's touchscreen to run the *Installation Startup Wizard*, guided step-by-step instructions and photos for filling the DI Water reservoir, priming the DI Loop, and rinsing down the measurement module.

- [“Installing the Calibration resistor” on page 77](#)
- [“Using the Instrument Startup Wizard” on page 77](#)

Installing the Calibration resistor

To install the calibration resistor

Use this instruction to install the resistor in the DI Loop. The calibration resistor is required for conductivity measurements and is shipped in the Analyzer's *Accessories* kit.

1. Locate the calibration resistor in the Analyzer's *Accessories* Kit.
2. Ensure to wear ESD protection.
3. Plug the two banana jacks of the resistor into the strip board (located behind the top sheet metal flange of the DI Loop).

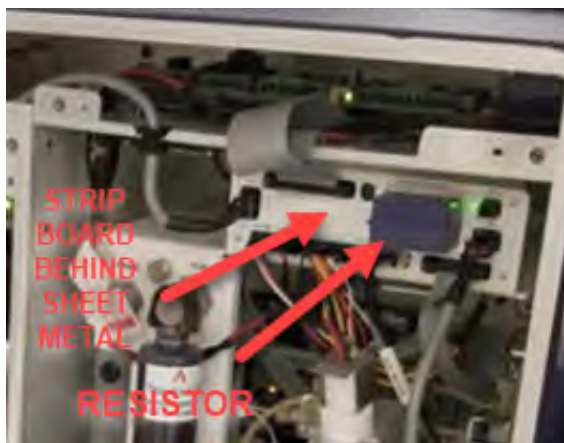

4. Continue to the next section, [To run the Instrument Startup Wizard](#).

Using the Instrument Startup Wizard

To run the Instrument Startup Wizard

This wizard guides the user (with step-by-step instructions and photos) through the process of filling the DI Water reservoir, priming the DI Loop, and rinsing down the measurement module. For additional details about the individual steps, refer to [Appendix D. "DI Water Installation Details."](#)

Chapter 3 INSTALLATION

1. Continue from [To install the calibration resistor](#).
2. Turn the rotary power switch (located on the left outside panel of the Analyzer; see [Figure 8](#) on [page 87](#)) to the *On* position to initiate power in the Analyzer. The touchscreen illuminates and displays the splash screen during the system initialization process.

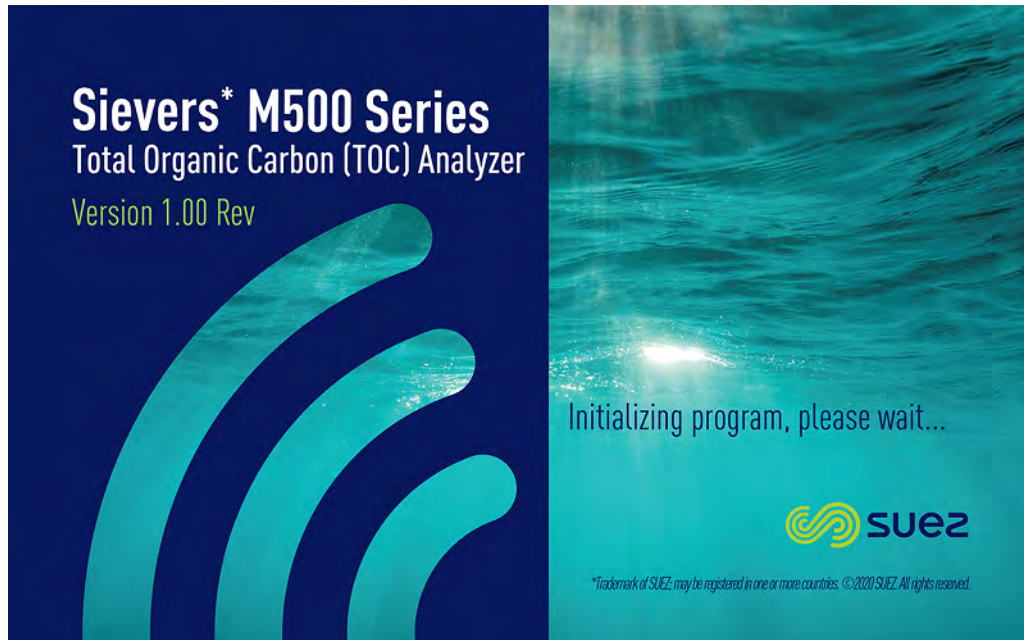

When initialization is complete, the *Home*  screen appears.

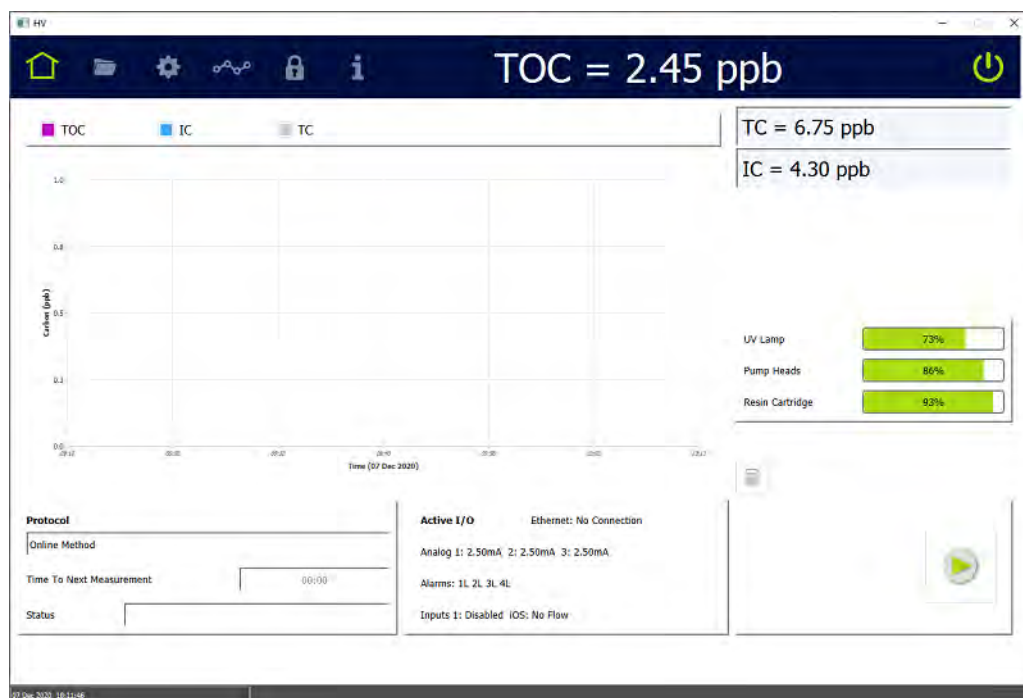



If DataGuard was activated at the factory, a **LOGIN** button appears in the lower right corner of the *Home*  screen and logging into the Analyzer is required. Follow the steps in [“To activate DataGuard” on page 91](#). When you finish, return to step 3 of this procedure.

3. Navigate to the *Settings*  screen and select the *Hardware* tab.

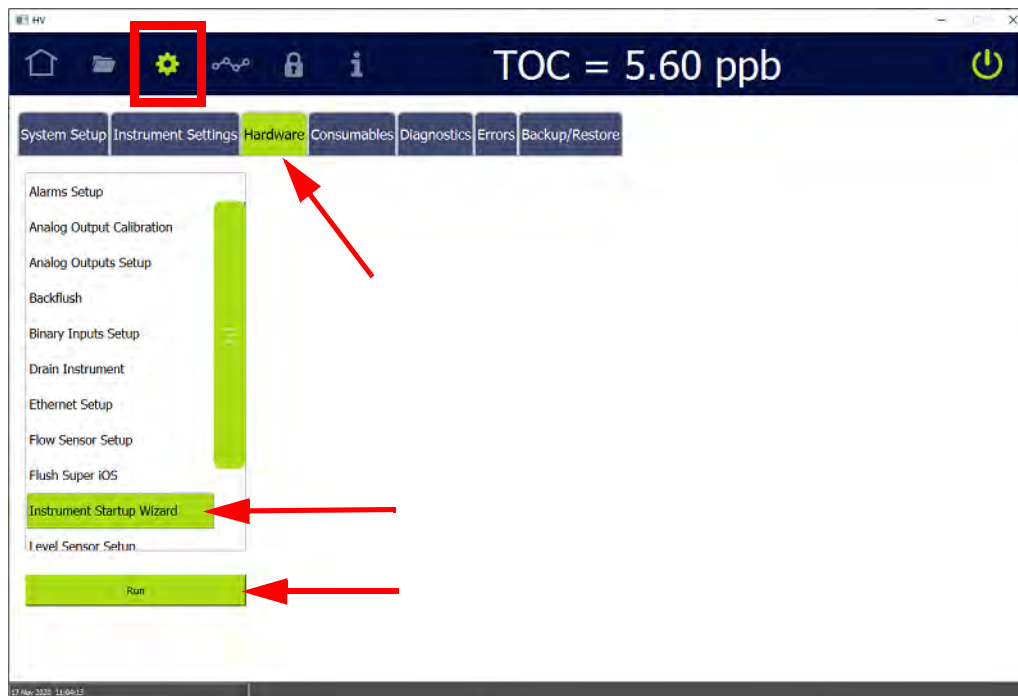

4. On the scrolling menu, select *Instrument Startup Wizard* and press **RUN**. The *Analyzer Startup Wizard* screen appears.



Chapter 3 INSTALLATION

5. Fill the dispensing bottle (from the Analyzer's *Accessories* kit) with low-TOC DI water and remove the check valve on the DI Water reservoir. Click **NEXT** to go to display the next wizard screen.

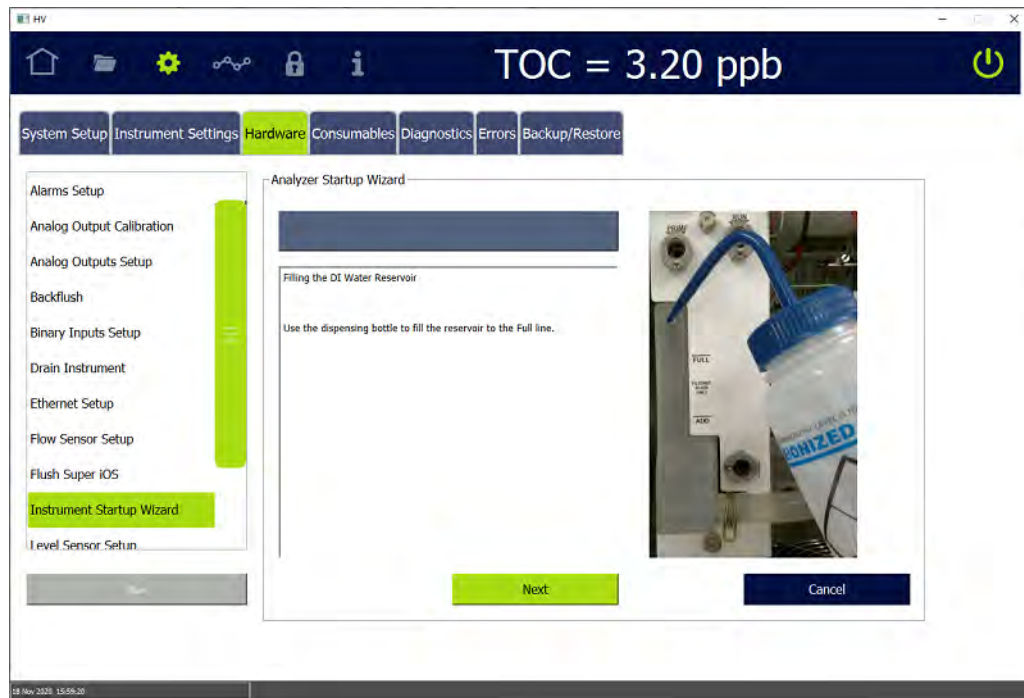

6. Use the dispensing bottle to fill the reservoir until the level reaches the *Full* indicator marking. Click **NEXT** to go to display the next wizard screen.

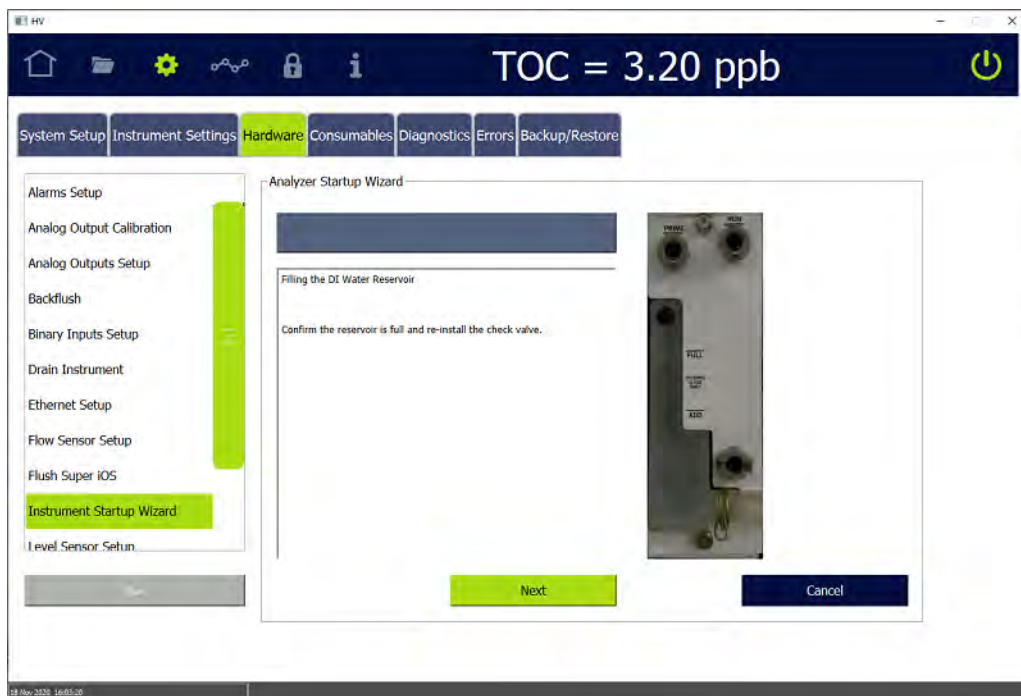



7. Confirm that the level of the DI water in the reservoir is at the *Full* indicator marking and re-install the check valve. Click **NEXT** to display the next wizard screen.

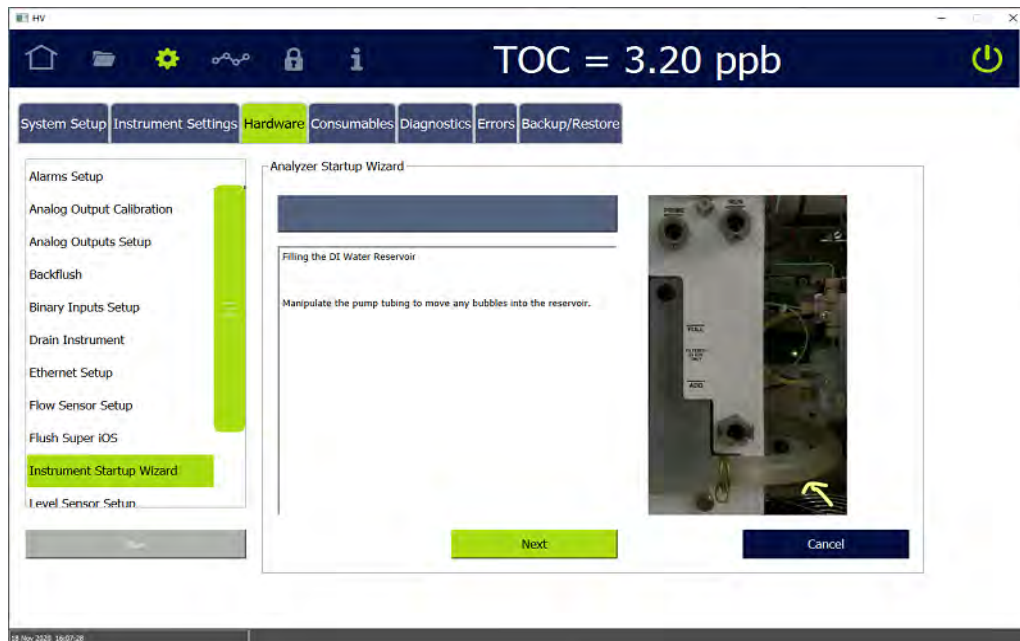

8. Manipulate the pump tubing to move any bubbles into the reservoir. Click **NEXT** to display the next wizard screen.

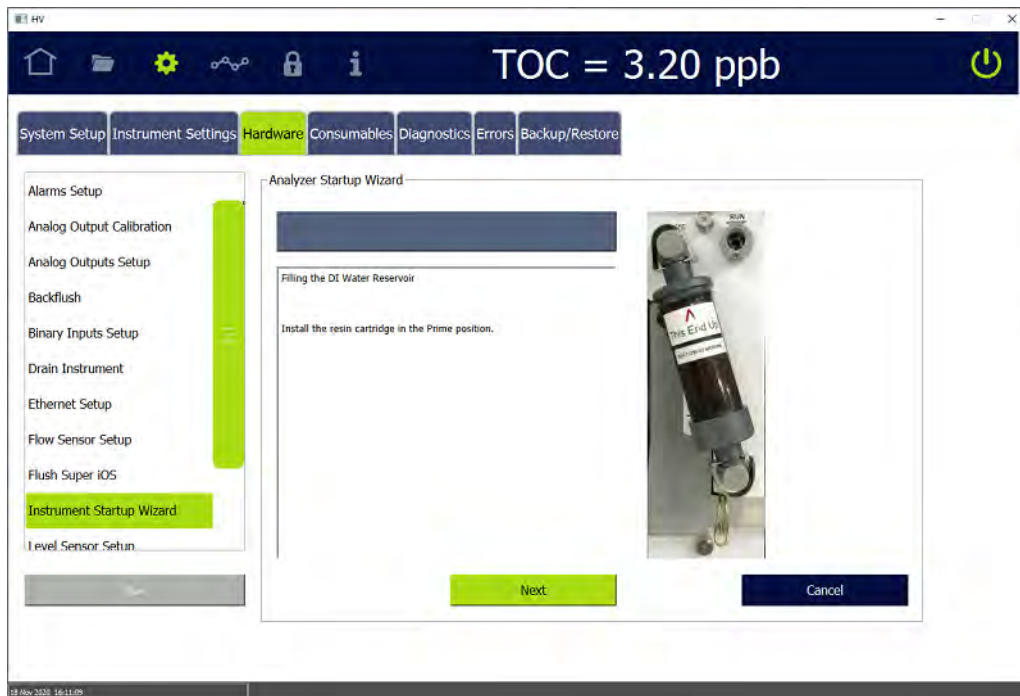

Chapter 3 INSTALLATION

9. Install the resin cartridge in the *Prime* position and click **NEXT** to display the next wizard screen. The Analyzer automatically starts priming the DI Loop.

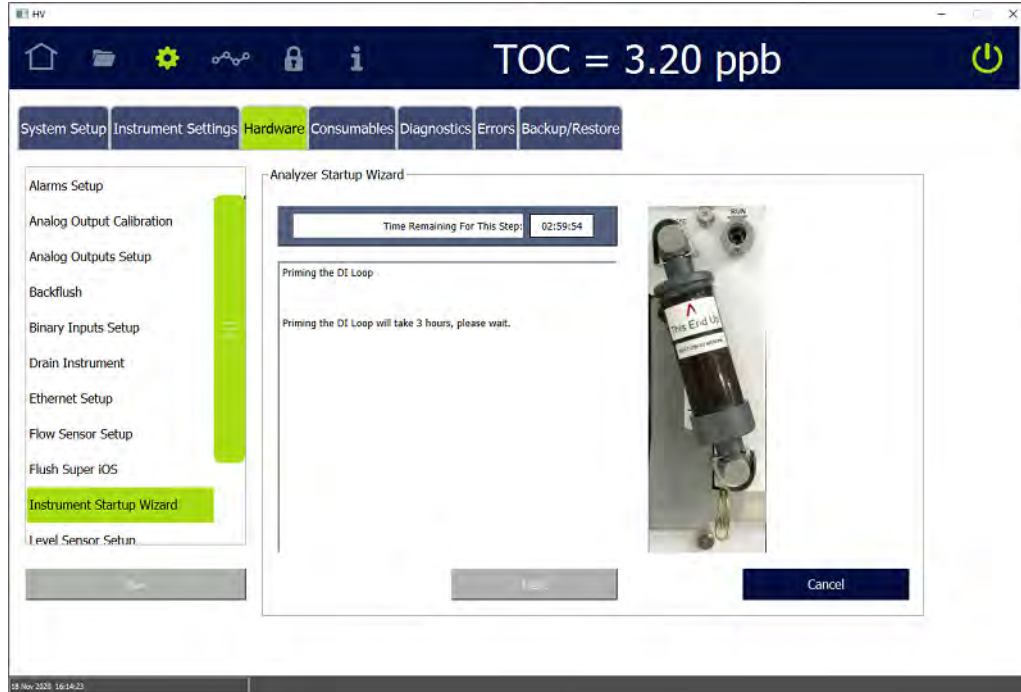

10. Wait (three hours) for the priming process to complete. After completion, the Instrument Startup Wizard displays a “Priming is complete.” message.



11. Click **NEXT** to display the next wizard screen.

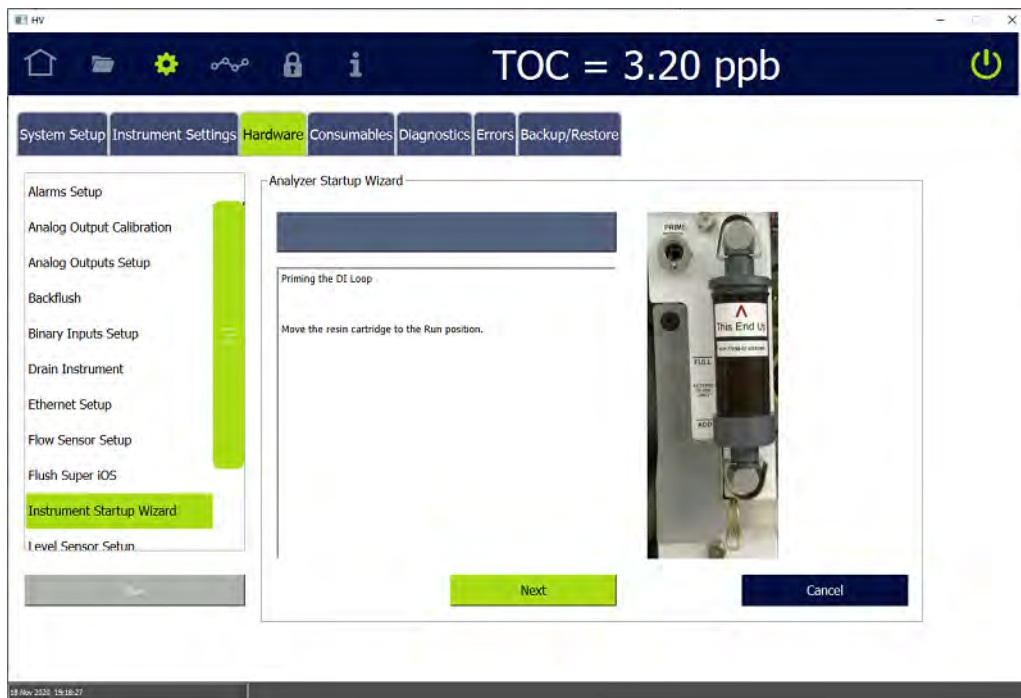

12. Move the resin cartridge to the *Run* position and press **NEXT** to display the next wizard screen.



13. Add more DI water to reach the *Full* line, if needed. (It is not necessary to re-prime the DI Loop.) Press **NEXT** to display a dialog box and the next wizard screen.

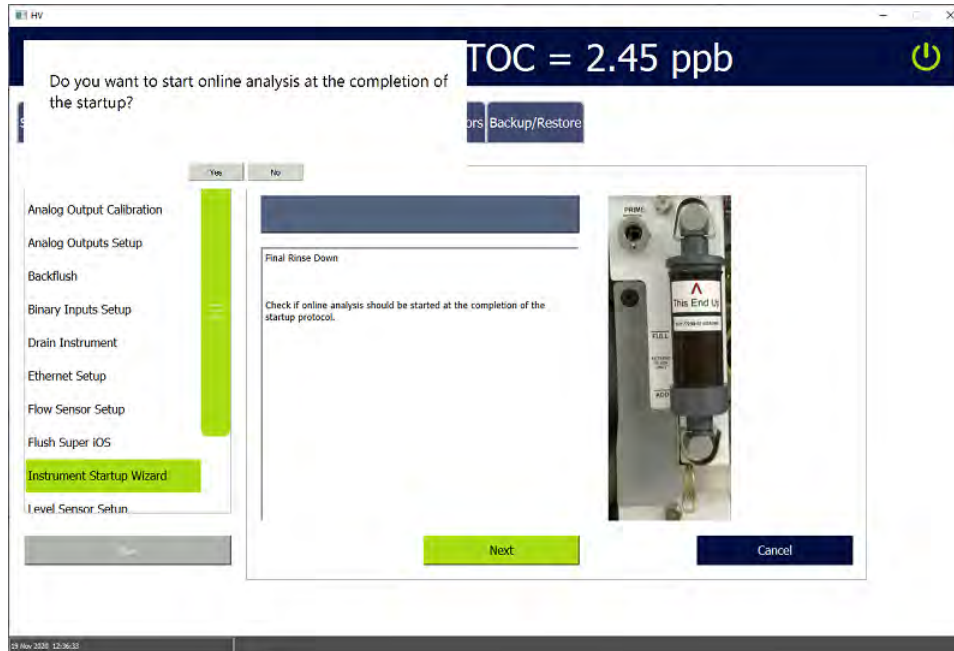

14. On the *Final Rinse Down* dialog box, do one of the following:

- To start online analysis at the completion of the Instrument Startup Wizard — Press **YES**.
- To avoid an automatic startup of online analysis at the completion of the Instrument Startup Wizard — Press **No**.

The dialog box clears.

15. On the *Analyzer Startup Wizard* screen, press **NEXT** to proceed to the next wizard screen.

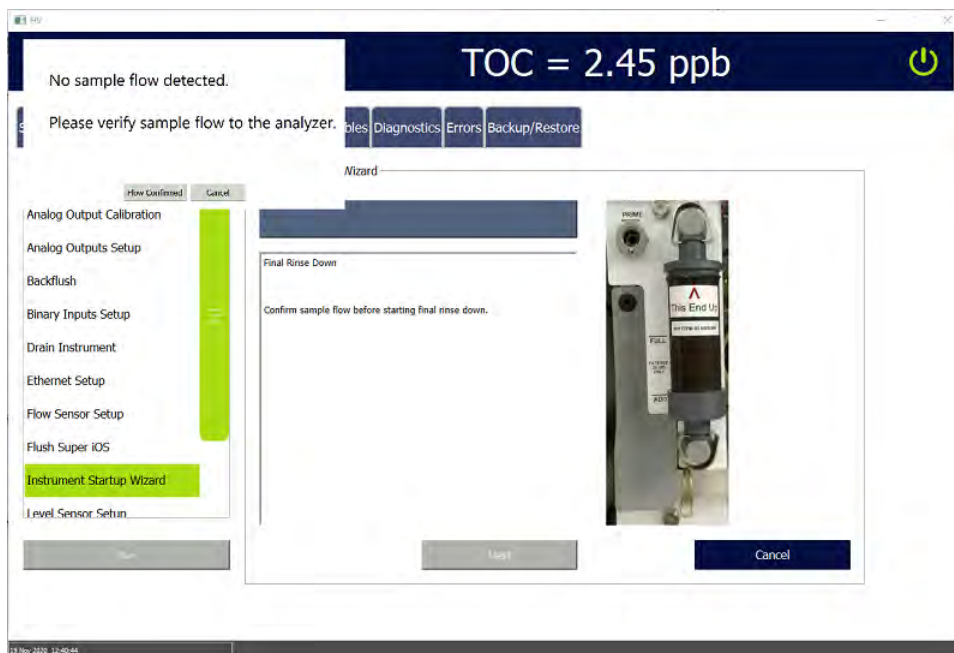

16. Confirm sample flow is established to the sample inlet system of the Analyzer and press **NEXT** to start the final rinse down and priming of the sample side. The Analyzer displays the next wizard screen.

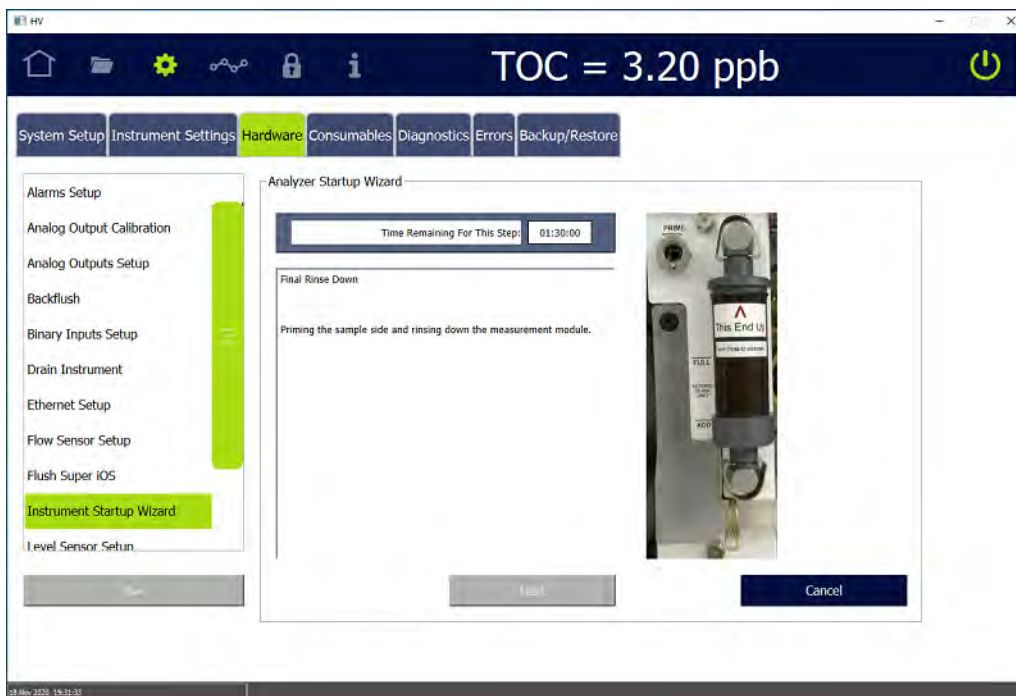

17. After completion of the final rinse down and priming of the sample side, the final wizard screen appears with the message: “Analyzer is ready for operation.”

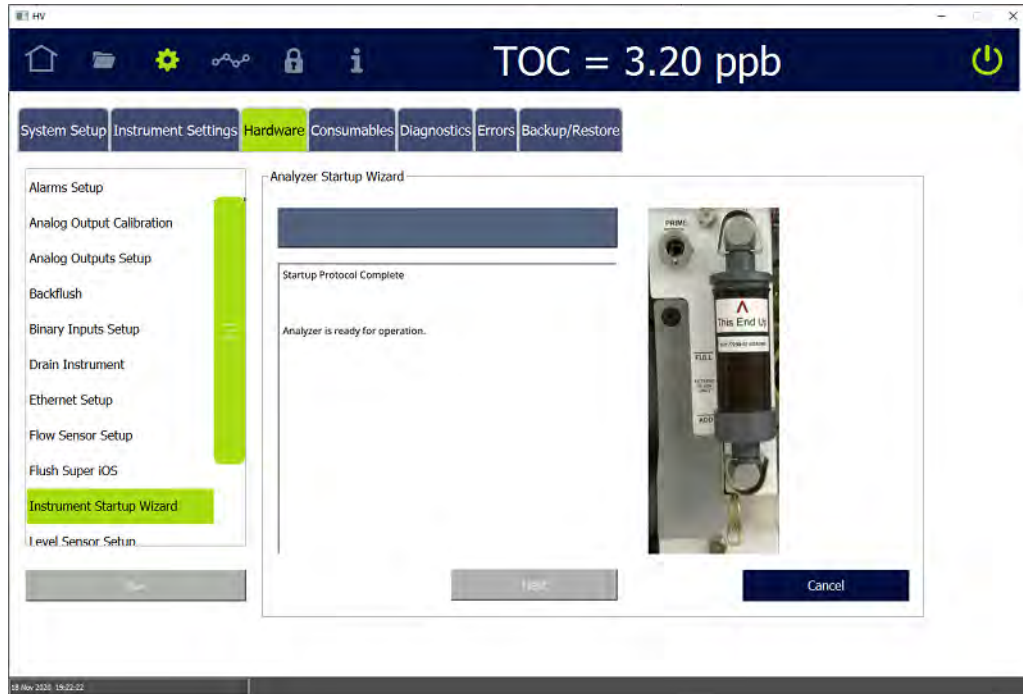

18. Go to the next section, [“Step 9: Configure Basic Analyzer Settings” on page 89.](#)

STEP 8: INSTALL ETHERNET AND EXTERNAL DEVICES

The Analyzer’s I/O panel is located on the outside left panel of the Analyzer’s enclosure and includes one Ethernet port, one RS-232 serial connection, and one antenna jack. The USB connection is available to transfer data via a USB memory device.

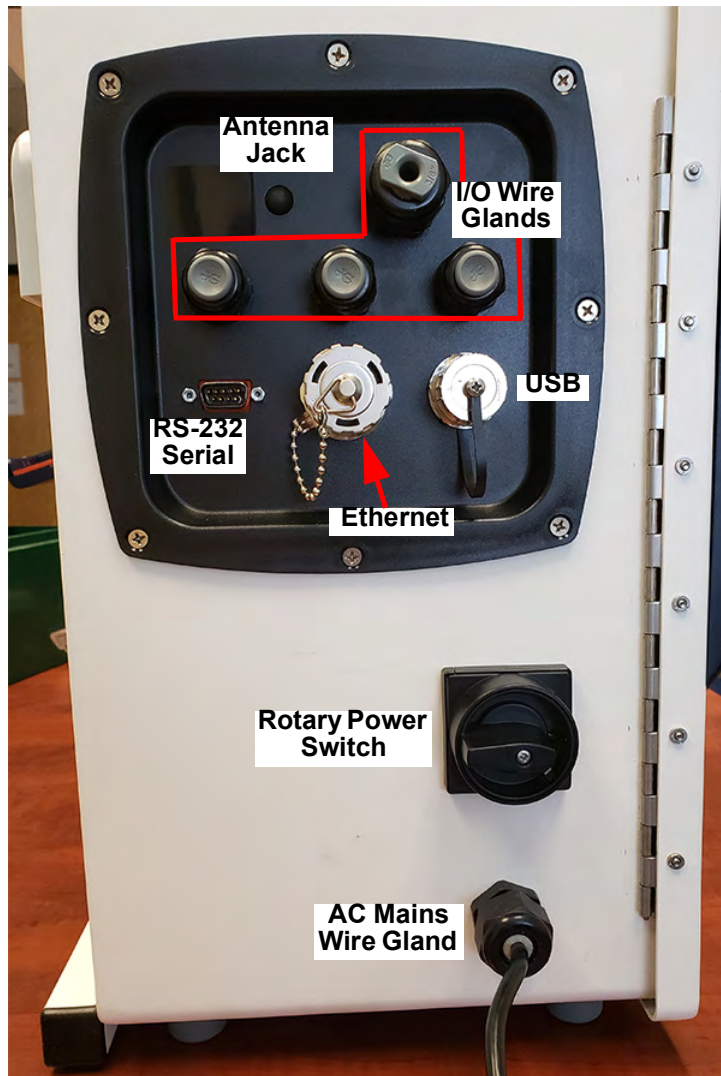

Figure 8: Input and Output Connections

The I/O panel also includes three I/O wire glands for connecting 4-20 mA and alarm wiring. The rotary power switch and an AC Mains wire gland (for installing power to the Analyzer) are located below these connections on the Analyzer's enclosure panel. Wiring and power installation are described in previous installation steps of this section.

Installing a USB Connection for Data Transfer (Optional)

The USB port provides data transfer to a USB memory device (for use in transferring exported data into a spreadsheet or database program) or from a USB memory device for firmware upgrades. The USB port does not facilitate connectivity to a computer.

To install a USB memory device, insert it into the USB port. (See [Figure 8: Input and Output Connections on page 87.](#)) The device must be oriented properly to slide into the port.



NOTE: Due to significant variance among USB memory devices, not all USB memory devices are compatible with the Analyzer.

Installing a Serial Connection (Optional)

The serial connection is provided as an optional means of capturing data from the Analyzer. Serial cables are available at many computer and office supply retail stores. Refer to [Figure 8: Input and Output Connections on page 87](#), and "[Figure 9: Asynchronous Serial Port \(RS-232\)](#)" on page 88, as needed.

To install a serial connection

1. Connect the male end of the serial cable to the port on the Analyzer labeled RS-232 and tighten the captive screws.
2. Connect the other end (female end) of the cable to the serial port on the computer and connect the captive screws.



NOTE: For long distance connections (up to 1,000 feet or 305 meters), SUEZ recommends use of either a RS-232 current loop converter or an RS-422 converter. Optionally, an Ethernet connection is available. See [Figure 8: Input and Output Connections on page 87](#).

Table 4: Isolated State Inputs (J2)

Pin Number	Signal	Function
2	RXD	M500 Normally Closed Contact
3	TXD	Data from the M500 Output
5	GND	DC Common
Others	(N/C)	No Connections

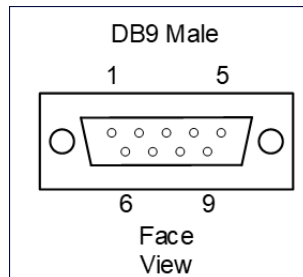

Figure 9: Asynchronous Serial Port (RS-232)



Installing an Ethernet Connection (Optional)

Ethernet connectivity is available for:

- Exporting historical data from the Analyzer to a computer, computer network, or Programmable Logic Controller (PLC).
- Printing to most PDF printers.

Attach one end of an Ethernet cable to the Ethernet port located on the left outside panel of the Analyzer ([Figure 8: Input and Output Connections](#)). Attach the other end of the cable to an Ethernet port on the network, to a computer, or to a printer. After installing the Ethernet cable, configure Ethernet in the Analyzer's firmware, "[Configuring an Ethernet Connection](#)" on page 165. To set up the printer for use with the Analyzer, see "[Enabling a PDF Printer](#)" on page 101. To assist in using the Modbus communications with the Analyzer, refer to [Appendix E. "Modbus with the Analyzer."](#)

To install an Ethernet cable

Provide either a cross-over Ethernet cable (for connecting directly to a computer or printer) or a straight-through Ethernet cable (for connecting to a network).

1. Attach one end of the Ethernet cable to the *Ethernet* port on the Analyzer. (See "[Input and Output Connections](#)" on page 87.) Attach the other end of the cable to an Ethernet port on a computer, a printer, or a network.
2. Configure Ethernet output later in this installation process during "[Step 9: Configure Basic Analyzer Settings.](#)"



NOTE: The Analyzer's USB port is not designed for Ethernet connectivity (using an Ethernet to USB adapter). For acceptable uses of the USB port, refer to the section "[Installing a USB Connection for Data Transfer \(Optional\)](#)" on page 87.

STEP 9: CONFIGURE BASIC ANALYZER SETTINGS

Before using the Analyzer, configure various basic settings. Most of these settings will not need to be changed again, unless the Analyzer is moved or the operational environment is reconfigured.

To customize additional settings, refer to [Chapter 4, "Basic Analyzer Operation"](#) on page 113.

Enabling Analyzer Security (Optional)

The Sievers M500 TOC Analyzer offers two levels of security, *Password Protection* and *DataGuard*. The *Password Protection* feature is included with all Analyzers and provides a basic level of security. The *DataGuard* feature is available as an option and

provides support for signing records in compliance with regulation 21 CFR Part 11. Enable **only one** of these security features, but not both.

This section includes step-by-step instructions for enabling *Password Protection* or activating the *DataGuard* option (along with minimal setup instructions). For more extensive *DataGuard* configuration instructions, and additional information about *Password Protection* and *DataGuard*, refer to [Chapter 5, "Password Protection and DataGuard."](#)

Enabling Password Protection (Optional)

To enable Password Protection

The Sievers M500 TOC Analyzer includes a *Password Protection* feature for setting one required password for all users to enable access to menu screens and to start analysis.



NOTE: If you are planning to activate *DataGuard*, there is no need to additionally activate this *Password Protection* feature. Instead, go to the next section, ["Activating DataGuard \(Optional\)."](#)

1. Go to the *DataGuard*  screen.
2. Select the *Enable Security Password* option.

Security

Enable Security Password

Password Settings

Login Attempts Before Alarm (2-10) 3

Inactivity Timeout (hh:mm) 10

Enter Password

Password *****

Confirm Password *****

Save Settings

3. Complete the following:
 - Login Attempts Before Alarm (2-10)
 - Inactivity Timeout (hours and minutes) — The minimum timeout is one (1) minute.

4. Press the *Password* field and use the alphanumeric keypad to enter a password.
5. Confirm the Password.
6. Press **SAVE SETTINGS**.
7. Record the new password in a secure location. ALL users will be required to enter this login information to access the Analyzer's menus.

Activating DataGuard (Optional)

Use this instruction to activate *DataGuard* and create an Administrator account (the minimum) needed before continuing with configuring basic Analyzer settings. See [“DataGuard” on page 194](#) for more extensive configuration instructions to perform after completion of this “Installation” chapter.

To activate DataGuard

1. If DataGuard was activated at the factory, press *Login* on the *Home*  screen.

If you are activating DataGuard after receiving an activation code, go to step [3](#).

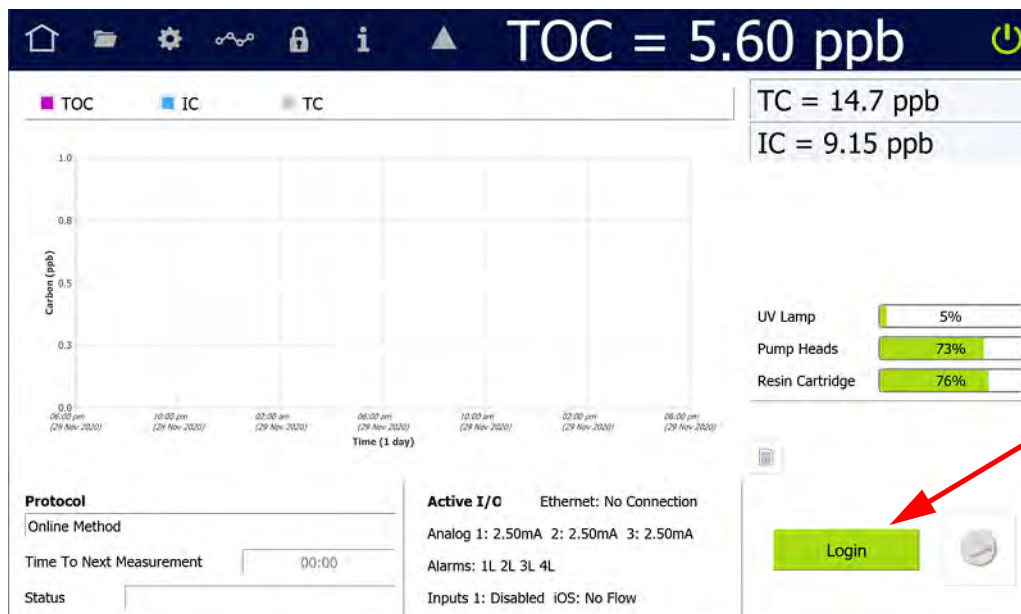

This message appears:

Chapter 3 INSTALLATION

No users have been setup.
Please add an Administrator account to this system.

OK

2. Press **OK**. Go to step [9](#).
3. Locate the *DataGuard* activation code previously forwarded from SUEZ for use in a later step in this procedure.
4. On the *Settings*  screen, select the *Instrument Settings* tab.

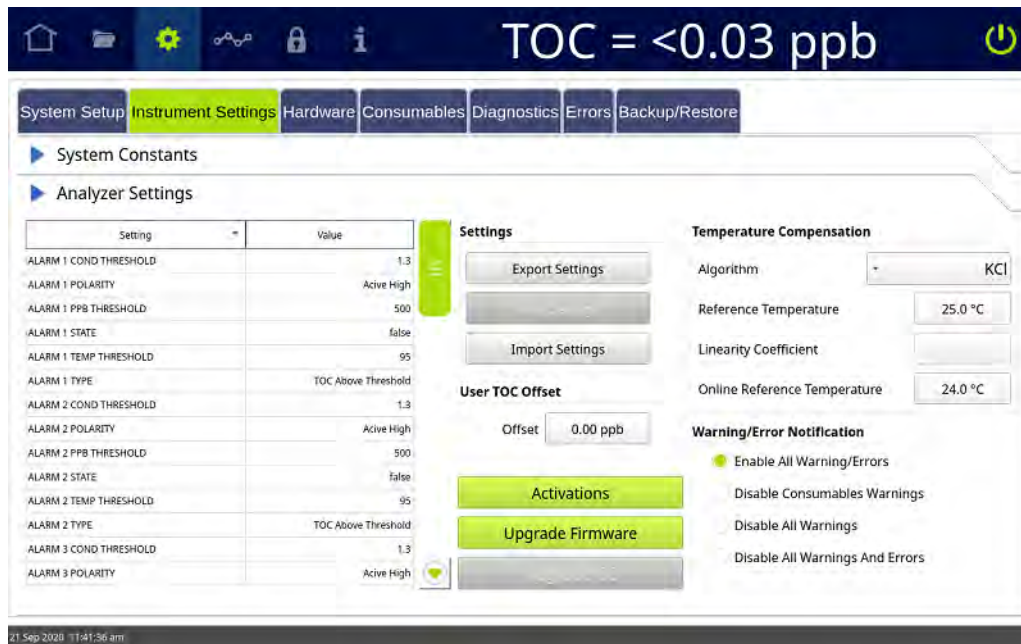

Setting	Value
ALARM 1 COND THRESHOLD	1.3
ALARM 1 POLARITY	Active High
ALARM 1 PPB THRESHOLD	500
ALARM 1 STATE	false
ALARM 1 TEMP THRESHOLD	95
ALARM 1 TYPE	TOC Above Threshold
ALARM 2 COND THRESHOLD	1.3
ALARM 2 POLARITY	Active High
ALARM 2 PPB THRESHOLD	500
ALARM 2 STATE	false
ALARM 2 TEMP THRESHOLD	95
ALARM 2 TYPE	TOC Above Threshold
ALARM 3 COND THRESHOLD	1.3
ALARM 3 POLARITY	Active High

5. On the *Analyzer Settings* panel, press **ACTIVATIONS**. The *Enter Activation Code* dialog box appears.

Enter Activation Code

8G9A-4UG4-0QMN

Features To Be Activated

Sample Conductivity Enabled

Apply Close



6. Press inside the *New Activation Code* field and use the alphanumeric keypad to enter the activation code provided by SUEZ. One or more features appear (depending upon the code provided) in the *Features To Be Activated* area.
7. Select the *DataGuard Enabled* feature and press **APPLY**. A confirmation message appears.
8. Press **YES** to continue. The *Enter Activations Code* dialog box closes and the system activates *DataGuard* on the Analyzer.
9. On the *DataGuard*  screen, select the *User List* tab.
10. Select *Add User*. The *User Settings* dialog box appears.

11. Press inside each of the following fields and use the alphanumeric keypad to enter the information, using the default parameters:
 - User ID (4-8 characters)
 - Last Name (up to 20 characters)
 - First Name (up to 20 characters)
 - Middle Initial (optional)
12. Ensure that **Administrator** is selected from the *Access Level* list and **Active** is selected from the *Status* list.
13. Press inside the *Password* field, and use the alphanumeric keypad to specify a password [The default settings are: total characters (4-8), upper case characters (0), and special characters (- or _) is (0)].
14. Press inside the *Confirm Password* field and use the alphanumeric keypad to type the same password.
15. Press **SAVE USER**. The *User List* tab appears with the new Administrator information.

Chapter 3 INSTALLATION

If DataGuard was activated at the factory, continue with [“To run the Instrument Startup Wizard” on page 77](#).

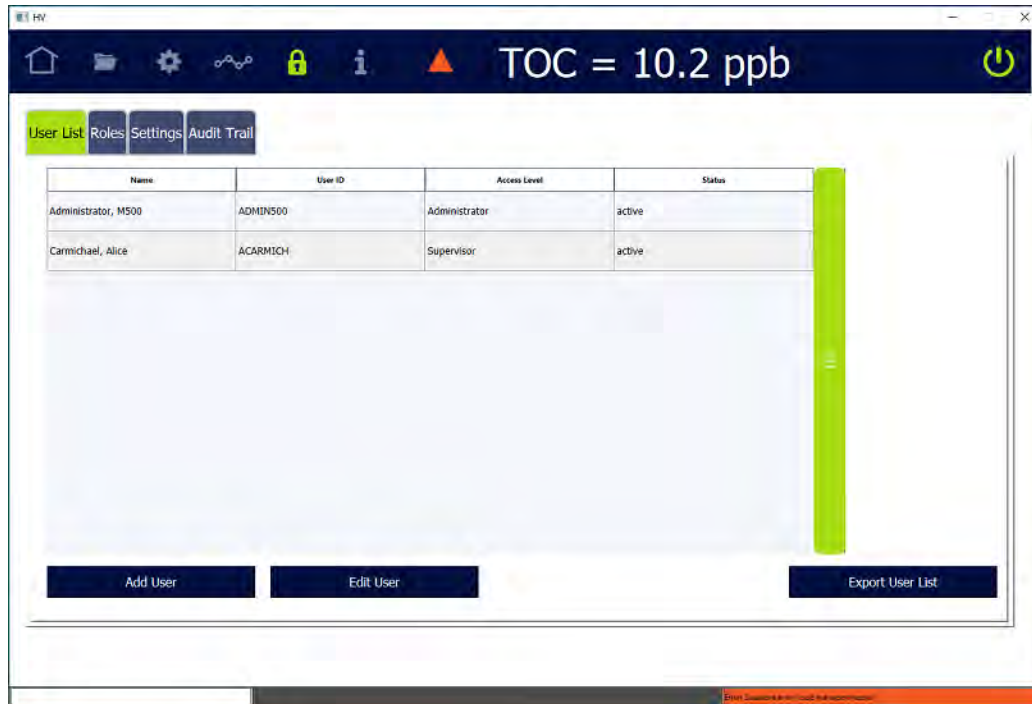

Configuring Local Settings

This section includes instructions for configuring settings for the local environment and display formats.

To configure the environment settings

Define the Analyzer name and location, service provider, and system language, or leave the default values. Also, use this instruction to set the system clock.

1. On the **Settings**  screen, select the *System Setup* tab.

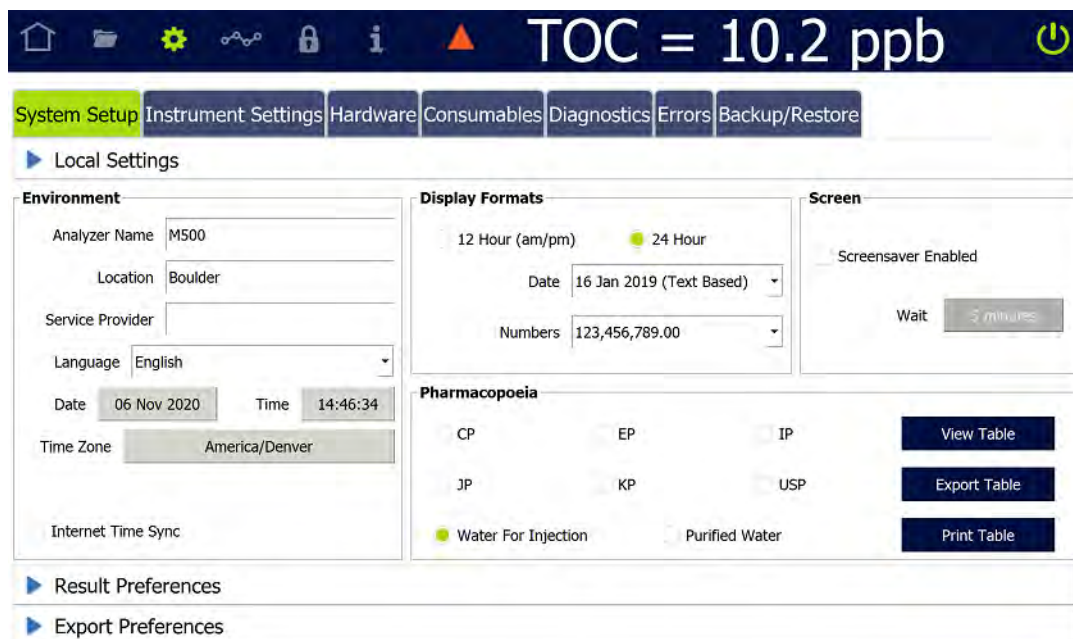

2. On the *Local Settings* panel (in the *Environment* section), press inside any of the following fields to use the alphanumeric keypad to specify an identifier and press **OK**.
 - Analyzer Name
 - Location
 - (Optional) Service Provider
3. Press the *Date* field and use the calendar to enter the current month, day, and year.
4. Press the *Time* field and use the numeric keypad to enter the hours, minutes, and seconds (hh:mm:ss).
5. If time is displayed in 12 Hour format, select the *am* or *pm* option and press **OK**.
6. Press the *Time Zone* field. Select the *Region* and then scroll through and highlight a location. Click **SELECT TIME ZONE**.
7. (Optional) Select (green box) or de-select (no green highlight in the box) *Internet Time Sync* [Automatically synchronizes the local computer time with the operating system's network time protocol (NTP) server].
8. Continue to the ["To configure the display format settings" on page 95](#).

To configure the display format settings

Configure the settings for the date format, the clock format, and number format for display.

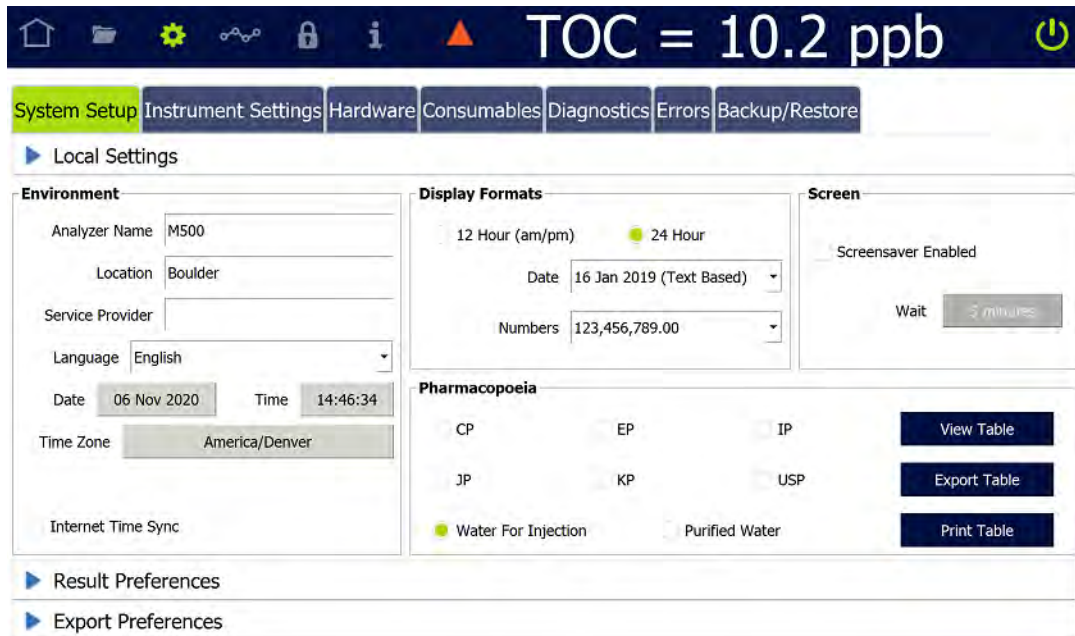

Chapter 3 INSTALLATION

1. On the *Settings*  screen, select the *System Setup* tab.
2. On the *Local Settings* panel, under *Display Formats*, select one of the following format options from the *Date* list:
 - Text Based — DD/MM/YYYY (16 Jan 2019)
 - Month First — MM/DD/YYYY (01/16/2019)
 - Day First — DD/MM/YYYY (16/01/2019)
 - Year First — YYYY/MM/DD (2019/01/16)



3. Select the *12 Hour (am/pm)* or *24 Hour* (24-hour clock format, such as 13:22) option to designate the time format.
4. Select one of the following format options from the *Numbers* list:
 - 123,456,789.00
 - 123.456.789,00

Setting the Measurement Mode

Before starting normal Analyzer operation, verify the default measurement mode setting for your application's configuration needs. The measurement mode is set using the *Protocols*  screen. The Analyzer uses this measurement mode setting for analysis started from the *Home*  screen (which also displays the active measurement mode in the *Protocols* field).

To revise the active measurement mode

1. On the *Protocols*  screen, select the *User Defined Methods* tab.

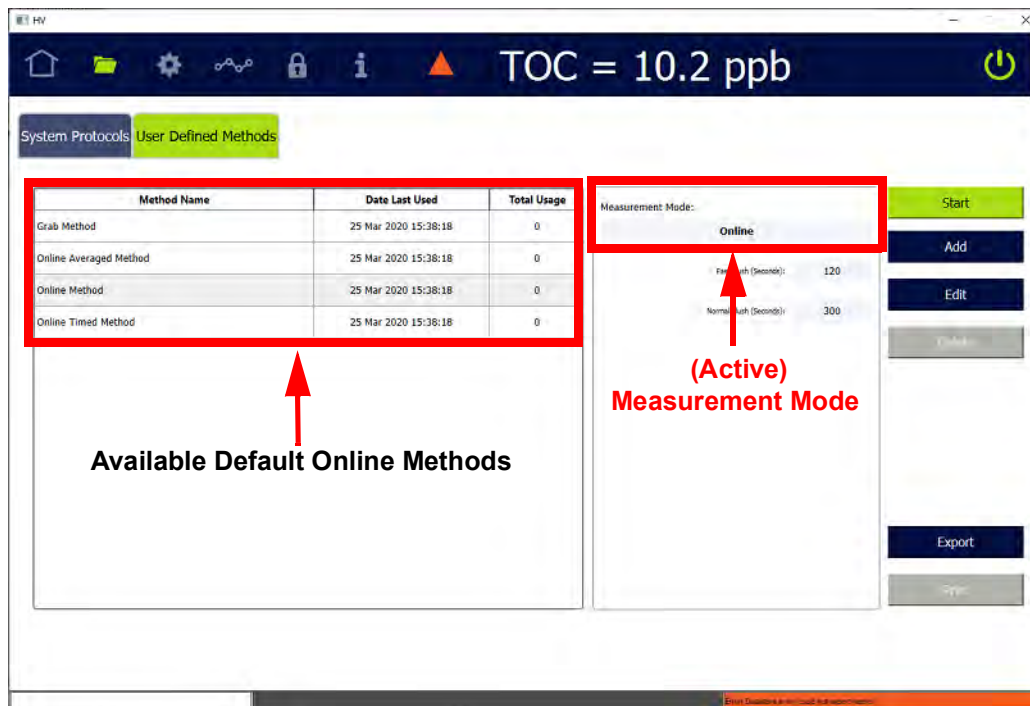

2. On the *Measurement Mode* panel (located on the right), verify the mode (method) appearing in the *Measurement Mode* field. Leave this mode or select one of the following from the *Method Name* table (located on the left):

- ONLINE METHODS (Select one.)
 - *Online* method — The Analyzer measures TOC continuously and returns measurement results every three minutes (with option) or six minutes (with base model).
 - *Online Timed* method — The Analyzer returns a single TOC measurement at specified times of the day.
 - *Online Averaged* method — The Analyzer returns the averaged value of TOC over a specific time interval.

The selected method appears as the measurement mode in the *Measurement Mode* field (on the *Measurement Mode* panel). Go to step [9](#).

- GRAB METHOD
 - *Grab Method* — The Analyzer performs analyses by drawing samples from a vial (placed in the designated vial port) in the Analyzer's iOS or

Chapter 3 INSTALLATION

Super iOS System. (Grab mode is not available for configurations with the Sample Inlet Block.)



NOTE: When measuring in Grab mode and using glass vials, the sample water must be acidified to a pH of three (3). If using plastic vials, no acidification is required.

The selected method appears in the *Measurement Mode* field (on the *Measurement Mode* panel). Go to step 3.

3. With *Grab* Method selected, leave the default parameters shown on the *Measurement Mode* panel or press **EDIT**. The *Edit Method* screen appears.

4. Press inside the *Method Name* field and use the alphanumeric keypad to enter a new name.
5. Select (green box) or de-select (no green highlight in box) the *Start Online When Done* option.
6. If using a Standard iOS System, the number in the *Number of Vials* field is 1. Continue to the next step.

If using a Super iOS System, press inside the *Number of Vials* field and use the numeric keypad to enter the number of vials (1- 4). The Analyzer activates a column of fields (*Sample Name*:, *Vial Type*:, *Number of Repetitions*:, *Number of Rejects*:) for each vial position.

7. Complete the following:
 - Fast Flush (Seconds) — Press inside the field and use the alphanumeric keypad to enter the number of seconds for a fast flush (120-600).
 - Normal Flush (Seconds) — Press inside the field and use the alphanumeric keypad to enter the number of seconds for a normal flush (300-1500).



8. Complete the following for each vial position:
 - Sample Name — Press inside the field and use the alphanumeric keypad to enter a name.
 - Vial Type — Select one of the following: *Sample Vial*, *Blank Vial*, *Standard Vial*, *Rinse Vial*.
 - Number of Repetitions — Press inside the field and use the numeric keypad to enter the number of replicate TOC measurements for the Analyzer to perform on the sample.
 - Number of Rejects — Press inside the field and use the numeric keypad to enter the number of replicate TOC measurements for the Analyzer to perform.



NOTE: Using at least four (4) repetitions allows rejection of the first value and calculation of a standard deviation using the remaining values.

9. Setting the measurement mode is complete and this measurement mode now appears in the *Protocols* field on the *Home* screen. The Analyzer automatically uses this measurement mode for analysis initiated with the **START ANALYSIS** button.

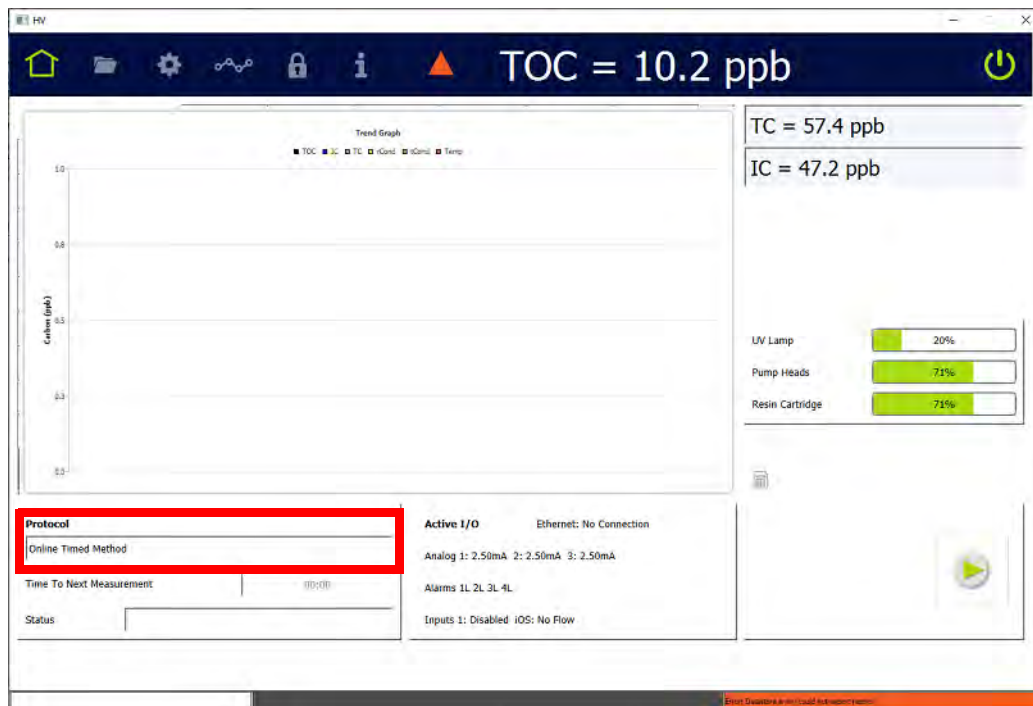

Configuring an Ethernet Connection

To configure an Ethernet connection

Use this instruction to enable the Ethernet connection and set up a manual (fixed) IP address or an automatic (dynamic) IP address.

After configuring the Ethernet connection:

- To collect data, use a third-party data acquisition software or a SCADA system with Modbus TCP/IP to support the collection of real-time instrument data and status information. For more information, refer to [Appendix E, "Modbus with the Analyzer."](#) To collect serial data strings, refer to ["Streaming Data" on page 433.](#)
 - To print to a PDF printer, configure the printer connection. For more information, refer to ["Enabling a PDF Printer" on page 101.](#)
1. On the *Settings*  screen, press the *Hardware* tab.



2. On the scrolling menu, select *Ethernet Setup* and press **RUN**. The *Ethernet Setup* dialog box appears.



3. Select the *Enable Ethernet Connection* option.
4. Do one of the following:
 - Select the *Automatic* option for a dynamic IP address.
 - Select the *Manual* option for a fixed address and enter the IP Address and Net Mask numbers.
5. Press **Save**.

Enabling a PDF Printer

After a direct or network Ethernet connection to a PDF printer has been set up and configured (refer to [“Installing an Ethernet Connection \(Optional\)” on page 89](#) and [“Configuring an Ethernet Connection” on page 100](#)), the PDF printer must be enabled in the firmware.

To enable a PDF printer

1. Ensure the PDF printer is connected to the Analyzer directly or over an Ethernet network.
2. On the *Settings*  screen, press the *Hardware* tab.

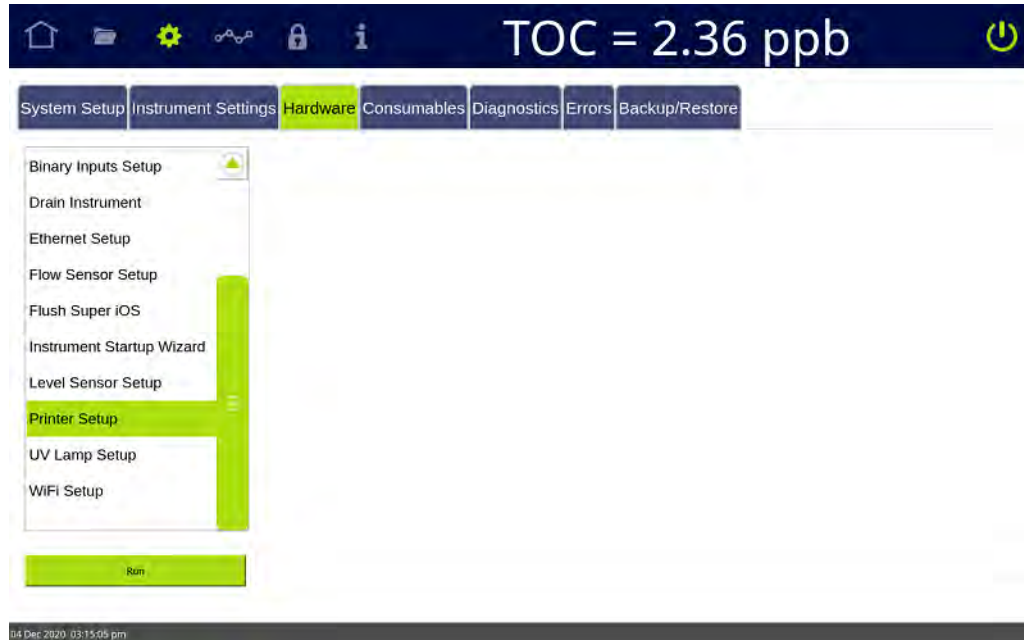

3. On the scrolling menu, select *Printer Setup* and press **RUN**. The *Printer Setup* dialog box appears. The Analyzer checks for all PDF printers that are available over the Ethernet connection and lists the printers in a dialog box.

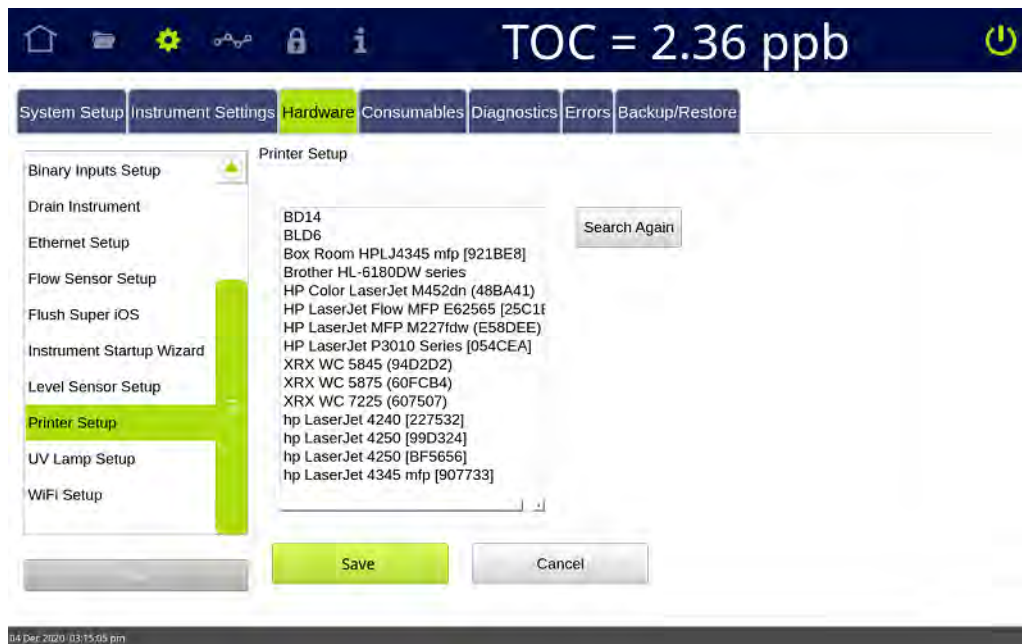

4. Select the printer to enable for use with the Analyzer.
5. Press **SAVE**.
6. To send a test page to the printer, navigate to the scrolling menu for *System Tests* (*Settings*  screen > *Diagnostics* tab).

7. Select *Printer* and press **RUN**. The Analyzer sends a test page to the printer.
8. Check the printer to ensure that it printed the test page. Consult the printer manufacturer's instructions for additional help, as needed.

Setting up a Wireless Connection

To configure a Wireless connection

Use this instruction to enable a wireless connection when the WiFi option has been purchased.



NOTE: This feature is only available in select countries.

1. On the *Settings*  screen, press the *Hardware* tab.

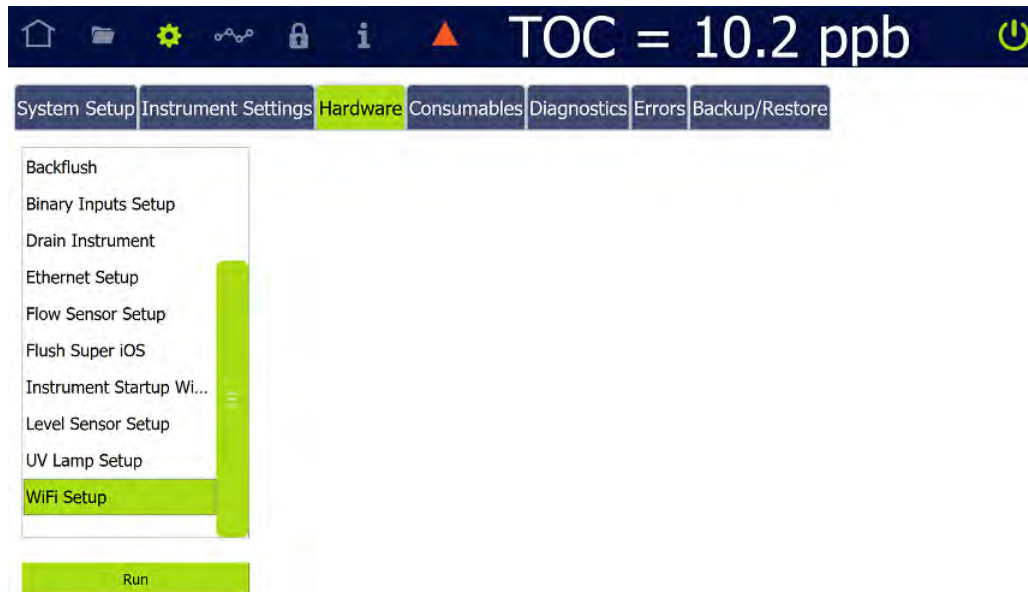

2. On the scrolling menu, select *WiFi Setup* and press **RUN**. The *WiFi Setup* dialog box appears.

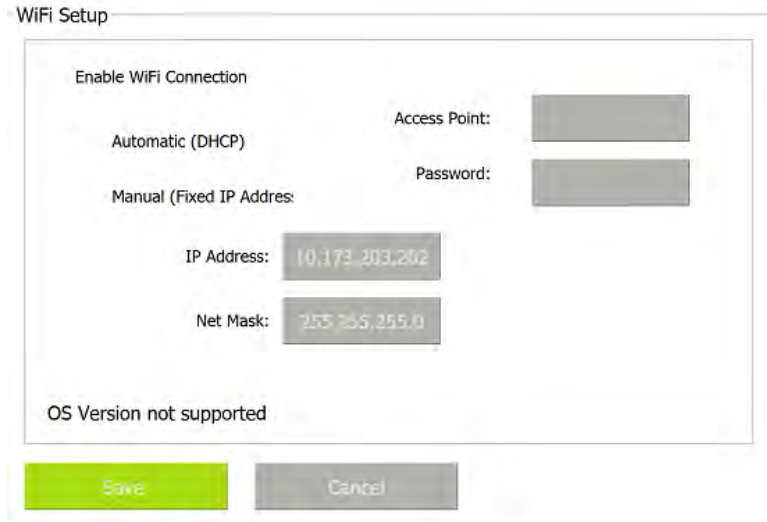

The image shows a 'WiFi Setup' dialog box with the following fields and options:

- Enable WiFi Connection:** A radio button that is currently selected.
- Automatic (DHCP):** A radio button that is currently unselected.
- Manual (Fixed IP Address):** A radio button that is currently unselected.
- IP Address:** A text field containing '10.173.203.202'.
- Net Mask:** A text field containing '255.255.255.0'.
- Access Point:** A dropdown menu that is currently empty.
- Password:** A text field that is currently empty.
- OS Version not supported:** A message at the bottom of the dialog.
- Buttons:** 'Save' (green) and 'Cancel' (grey) buttons at the bottom.

3. Select the *Enable WiFi Connection* option.
4. Do one of the following:
 - Select the *Automatic* option for a dynamic IP address.
 - Select the *Manual* option for a fixed address and enter the IP Address and Net Mask numbers.
5. Select the *Access Point* field. Select the access point.
6. If the WiFi network requires a password, select the *Password* field and enter the password.
7. Press **Save**.

Saving System Constants

Print or export system constants (calibration and user-configurable settings) to a USB memory device or network path. This feature provides a record of the system constants in the event there is a need to return to previous settings.



NOTE: When you perform a backup, the Analyzer backs up the system constants along with the historical data. You can restore the system constants in any backup file without restoring the historical data. For more information see [“Backing Up the Database” on page 175](#) and [“Restoring System Constants” on page 184](#).

To print and export system constants

1. On the *Settings*  screen, select the *Instrument Settings* tab.



2. (Optional) To print the system constants:
 - Ensure a PDF printer is connected to the Ethernet port (either directly or over a network) and the PDF printer is enabled in the firmware. (For information, see [“Enabling a PDF Printer” on page 101.](#))
 - On the *System Constants* panel press **PRINT**. The Analyzer prints a copy of the system constants.
 - Save the printout. Technical Support or your local service provider might need to reference the system settings for Calibration constants and other key parameters.
3. If using a USB memory device for the export, insert it into the USB port.
4. Press **EXPORT**. The *Export* screen appears.

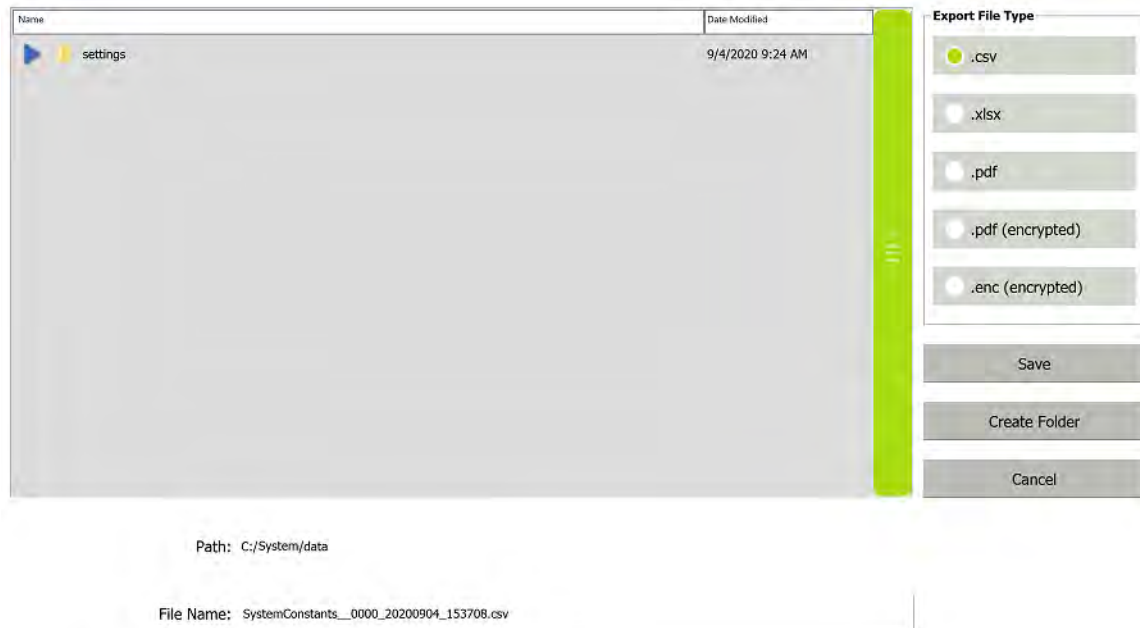

5. In the *Export File Type* area, leave the default file type(s) or select one or more of the following:

- .csv
- .xlsx
- .pdf
- .pdf (encrypted)

The password required to open the PDF file is specified on the *Export Preferences* panel. See [“Configuring Export Preferences” on page 145](#).

- .enc (encrypted)

6. Leave the default destination or add a folder to it by pressing the **CREATE FOLDER** button. Use the alphanumeric keypad to type a folder name and press **OK**. The Analyzer adds the folder to the export path configured on the *Export Preferences* panel, and displays the folder in the *Path* field and in the **Name** area.



NOTE: The export path represents the default destination of USB memory device or a network location, as configured on the *Export Preferences* panel (Settings  screen > System Setup tab). To revise the default destination, see [“Configuring Export Preferences” on page 145](#).

7. Leave the default file name or press inside the *File Name* field. Use the alphanumeric keypad to type a new file name (but not a file type extension)



and press **OK**. The exported file(s) are assigned the file type extension(s) selected in step 5.

8. In the **Name** area, select the folder to receive the exported file and press **SAVE**. A confirmation message appears.

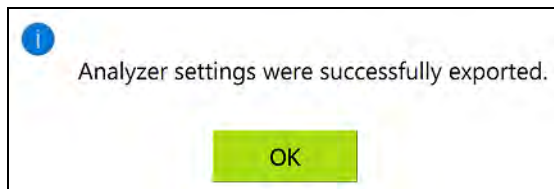

9. Press **OK** to confirm and close the message.
10. If a USB device was used, remove it for safe keeping.
11. Save the exported Settings file. Technical Support (or your local service provider) might need to reference the system settings for Calibration constants and other key parameters.

Configuring the Data I/O

If alarm outputs, 4-20 mA outputs, and/or binary inputs were installed, configure the connections with the appropriate values for those features now.



NOTE: You may need to consult with your remote operations center to determine some of the values.

To setup alarm output

The Analyzer has four customizable alarm outputs, configurable to trigger if the measured TOC, TC, or IC exceeds a set value — or if a warning or error occurs. Use this instruction for configuring the alarms wired earlier in [“Step 4: Install I/O Control Wiring \(Optional\)” on page 64](#)

1. On the *Settings*  screen, select the *Hardware* tab.

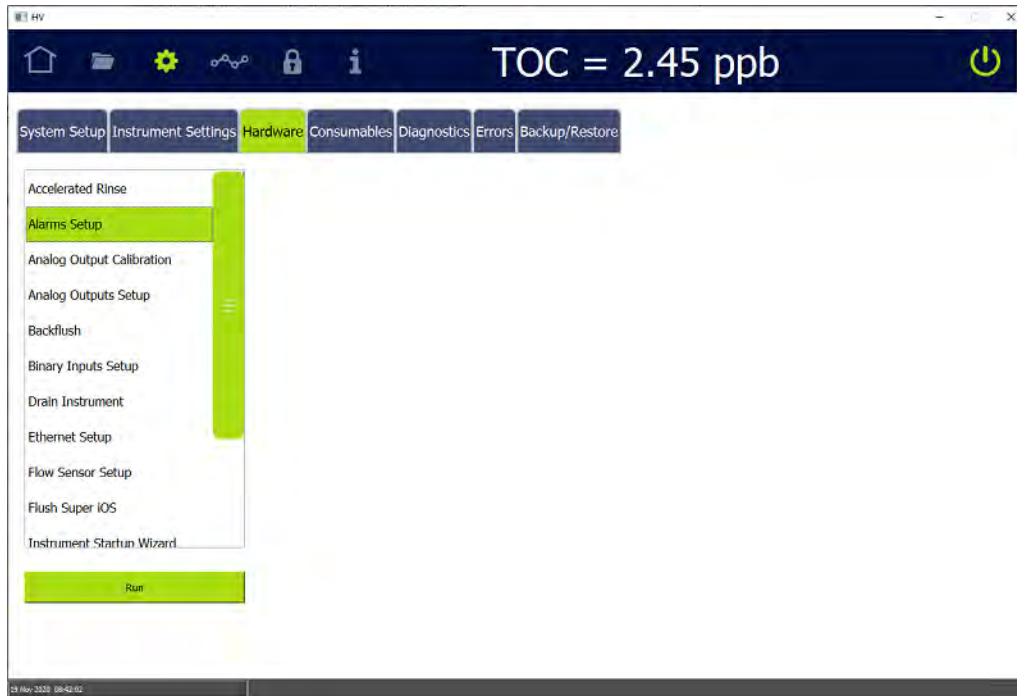

2. On the scrolling menu, select *Alarms Setup* and press **RUN**. The *Alarms Setup* screen appears.

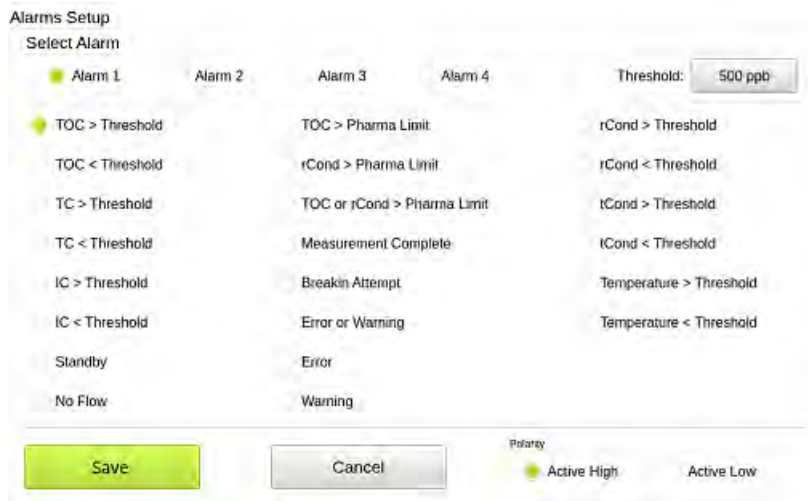

3. In the *Select Alarm* area, select one of the following options to configure (*Alarm 1*, *Alarm 2*, *Alarm 3*, or *Alarm 4*).
4. Press the *Threshold* field and use the numeric keypad to set a value for the alarm threshold (1-3000 ppb) and press **OK**.
5. In the table area, select an assignment option for applying the alarm (such as *TOC>Threshold*, *Error or Warning*, or *Temperature > Threshold*).
6. Repeat steps [3](#) - [5](#) for each alarm to configure.

7. Press **SAVE**.

To set up 4-20 mA analog outputs

1. On the *Settings*  screen, select the *Hardware* tab.

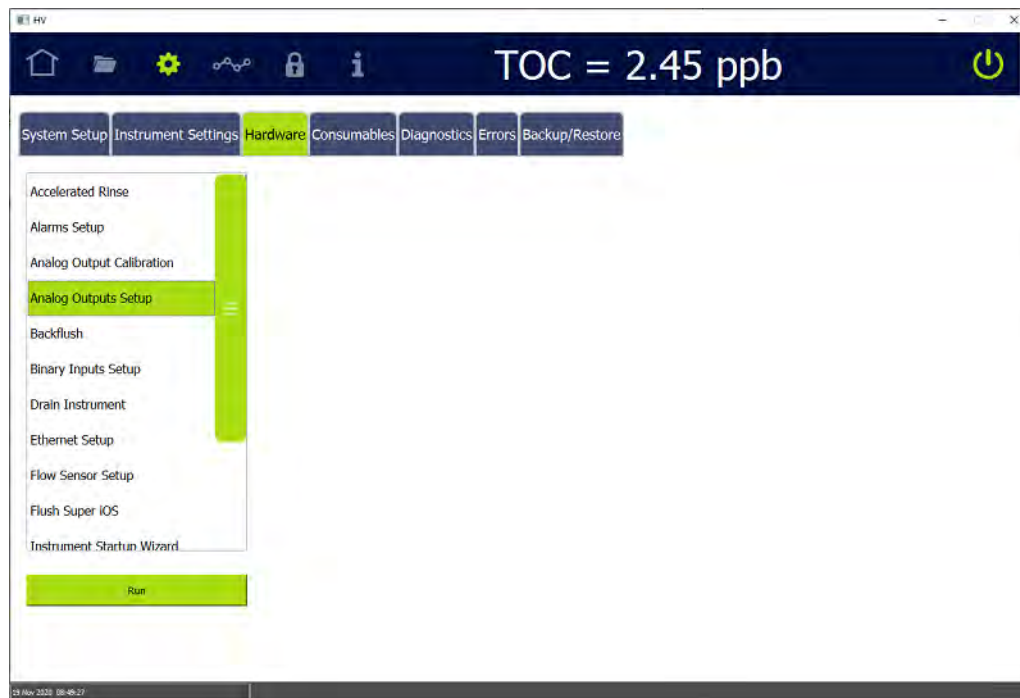

2. On the scrolling menu, select *Analog Outputs Setup* and press **RUN**. The *Analog Outputs Setup* screen appears.

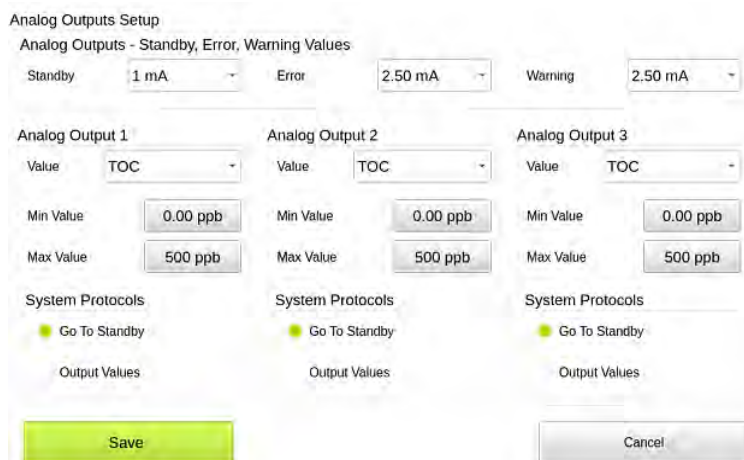

3. In the *Analog Outputs - Standby, Error, Warning Values* area, select values for each of the following:

- **Standby** — Select one of the following values to set when the Analyzer switches out of analysis mode into standby mode: *1 mA, 2.5 mA, 4 mA, 20 mA, 22 mA* or *Hold Last*.

- **Error** — Select one of the following values to set when the Analyzer issues an error: *1 mA, 2.5 mA, 4 mA, 20 mA, 22 mA* or *Hold Last*.
 - **Warning** — Select one of the following values to set when the Analyzer issues a warning: *1 mA, 2.5 mA, 4 mA, 20 mA, 22 mA* or *Hold Last*.
4. In the area for the analog output to configure (1, 2, or 3), specify the calibration values:
- **Value** — Select the analog output value (TOC, TC, or IC).
 - **Min Value** — Enter the lowest value (ppb) for output.
 - **Max Value** — Enter the highest value (ppb) for output.
 - **System Protocols** — Select one of the following for running system protocols: *Go To Standby* to output the Standby value entered in step 3 or *Output Values* to output actual values from protocol analyses.

To set the binary input

Enable the binary input connection for communicating remote start and stop commands to the Analyzer.

1. On the *Settings*  screen, select the *Hardware* tab.



2. On the scrolling menu, select *Binary Inputs Setup* and press **RUN**. The *Binary Inputs Setup* screen appears.



3. In the area for the Binary input to configure, select the *Enable Binary Input 1* (or *Enable the Binary Input 2*) option.
4. Select the *Run analysis when input is high* or the *Run analysis when input is low* option.
5. Repeat steps [3](#) through [4](#) for the other binary input connection.
6. Press **SAVE**.

THIS PAGE IS INTENTIONALLY LEFT BLANK.

4

BASIC ANALYZER OPERATION

.....

OVERVIEW

The Sievers M500 TOC Analyzer utilizes a backlit 10.1" color touchscreen display (1280 x 800) for all menu selection activities. This chapter describes these Analyzer screens and related setup and operation activities of the Analyzer.

An overview of the screens is given in ["The Analyzer Screens" on page 120](#). (Analyzers configured with a Sample Inlet Block, rather than an iOS System, may contain menu options that may not be relevant or menus with some inactive options.)

Powering On and Off the Analyzer

This section includes instructions for turning on the Analyzer power and, if *Password Protection* or *DataGuard* is enabled, logging into the Analyzer. Instructions for closing the Analyzer files and turning off power to the instrument are also included, as well as references to shutting down the mains power supply for some installation and maintenance activities.

Warning





To avoid injury and to ensure accurate analysis results, ensure that the Analyzer door is closed and latched during normal operation.

To power on the Analyzer

1. Turn the rotary power switch (located on the left outside panel of the Analyzer; see [Figure 8](#) on [page 87](#)) to the *On* position to initiate power in the Analyzer. The touchscreen illuminates and displays the splash screen during the system initialization process.

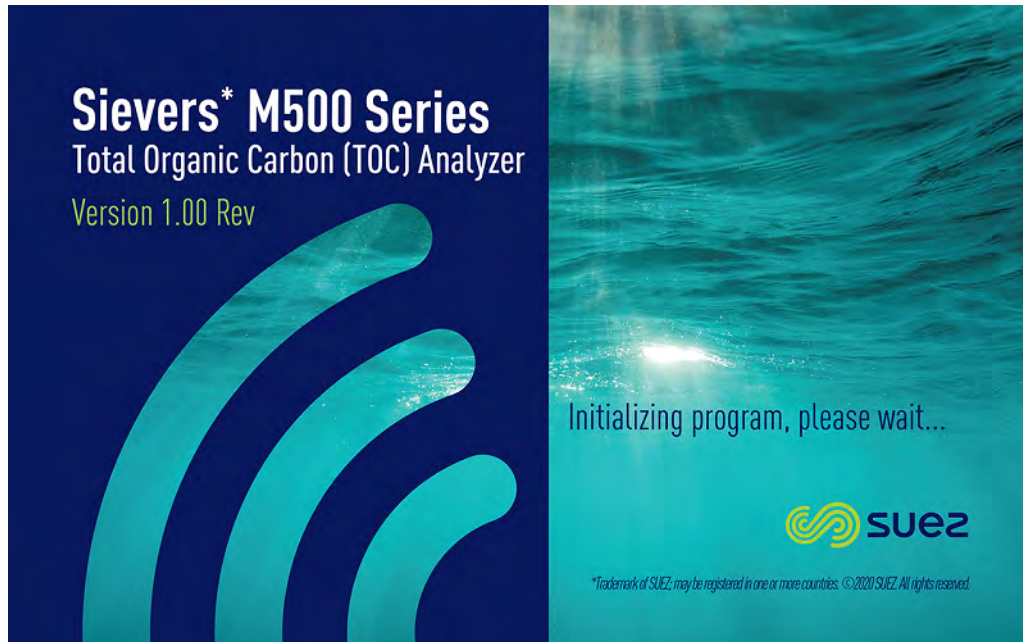
Chapter 4 BASIC ANALYZER OPERATION



When initialization is complete, the *Home*  screen appears.

If *Password Protection* or *DataGuard* is enabled, a **LOGIN** button appears in the lower right corner of the *Home*  screen, and logging into the Analyzer is required before starting analysis or proceeding to other screens.

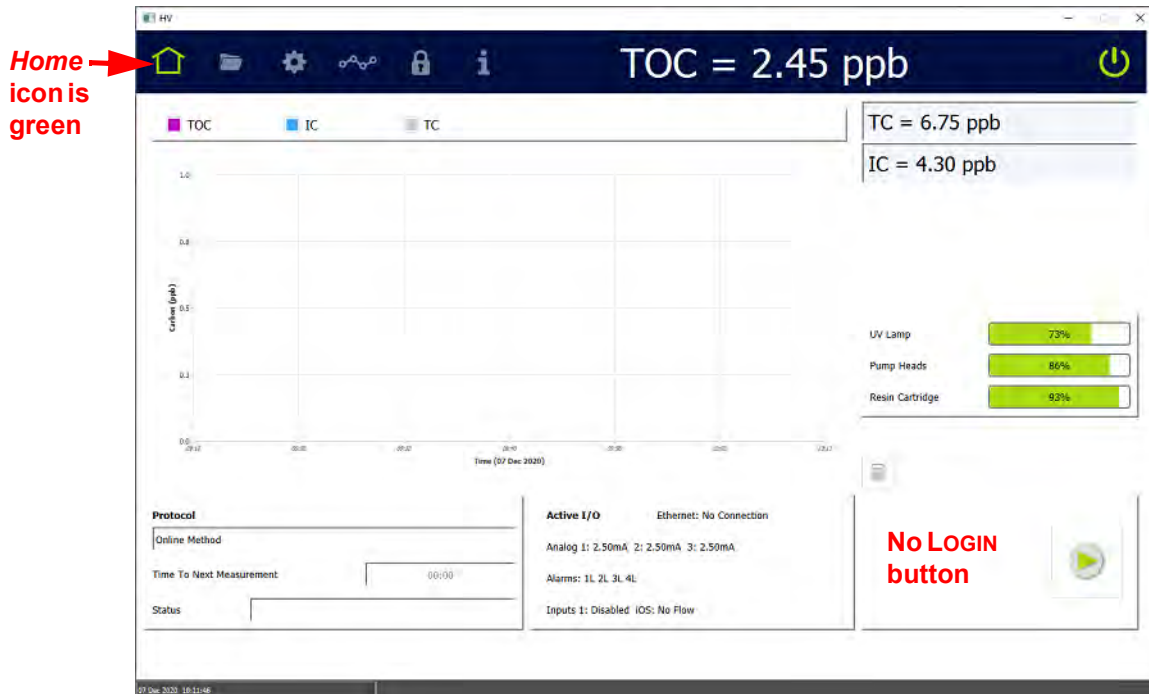

Figure 10: Home screen when Password Protection or DataGuard is not enabled

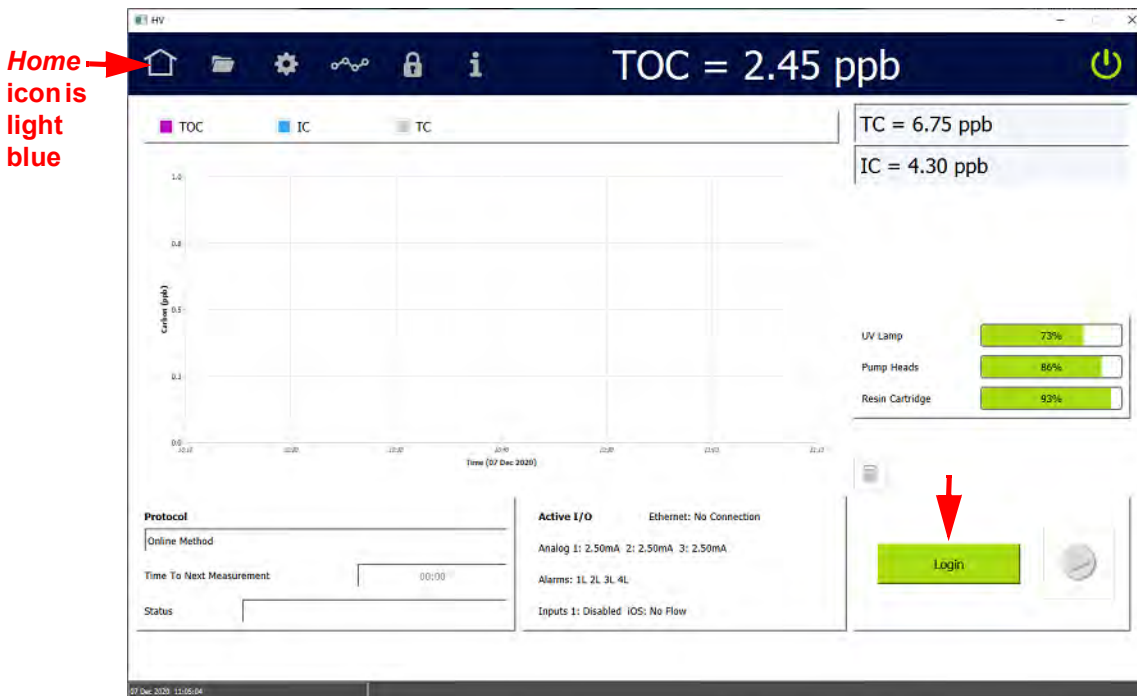



Figure 11: Home screen when Password Protection or DataGuard is enabled

2. If login is required, press the **LOGIN** button. The *Login* dialog box appears.
3. For *Password Protection*, press the *Password* field and use the alphanumeric keypad to enter a password.

For *DataGuard*, press inside the *User ID* and *Password* fields and use the alphanumeric keypad to enter your User ID and password.

4. Press the **LOGIN** button on the *Login* dialog box. When the login process is successful, the dialog box disappears and the *Home*  icon turns green.

For more information about *Password Protection*, see [“Password Protection” on page 191](#). For more information about *DataGuard*, see [“DataGuard” on page 194](#).

To power off the Analyzer

The Sievers M500 TOC Analyzer has a **POWER OFF**  button on the Analyzer’s *Home* screen to close all the files and an *On/Off* rotary power switch located on the left outside panel of the Analyzer.

For some maintenance activities (as described in applicable procedures) inside the Analyzer, SUEZ also recommends shutting down the mains power supply.

1. On the Analyzer’s *Home* screen, press **POWER OFF**  to close all the files.
Turn the rotary power switch (located on the left outside panel of the Analyzer) to the **Off** position to complete the power off cycle.



NOTE: The power cycle is not complete until turning the rotary power switch to the Off position. This ensures that power to all circuit boards is disconnected.



2. If planning to perform maintenance inside the Analyzer, shut down the mains power supply.

RECOMMENDED OPERATIONAL STATE

To assure optimal performance across the operating range, ensure the Analyzer remains powered *On* when not in use. This allows the measurement components and other subsystems to maintain equilibrium with the ambient environment. If the Analyzer cannot be left powered *On* between uses, allow the Analyzer to re-equilibrate for 90 minutes prior to beginning analysis. Failure to do so may compromise the Analyzer's initial results, including a decrease in accuracy, an increased likelihood of obtaining negative TOC values, or an increase in the standard deviation values.

THE iOS SYSTEMS

SUEZ offers three inlet systems for use with the Sievers M500 TOC Analyzer: a *sample inlet block* for dedicated Online analysis, a *Standard Integrated Online Sampling (iOS) System* with one vial port, and a *Super iOS System*, with four vial ports. Both iOS Systems provide a convenient sample inlet for Online sample sources and standards in vials. Switching between *Online* mode analysis and grab sampling with one of the iOS Systems is performed without any need to change the inlet configuration.

Warning	
	<p>Water in the iOS System may be hot. Before inserting a vial into the iOS System after operating in Online mode, slide the door open and wait 30 seconds to allow sample to completely drain. Inserting a vial before draining can result in hot water spray projecting upward out of the iOS System.</p>
	<p>The iOS System and vial ports contain sharp needles designed to pierce the septa of sample vials. Do not put fingers or inappropriate materials into the iOS System or vial ports.</p>

Using the Standard iOS System

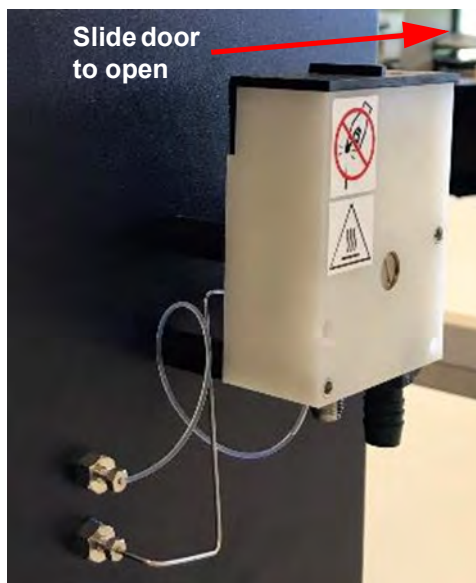

Figure 12: The Standard iOS System

Simply insert a vial into the single vial port on the Standard iOS and run a grab method analysis.

Always stop analysis before opening the standard iOS System door to avoid generating erroneous measurement data.¹

¹. If the flow sensor is **On**, opening the iOS System door while analysis is taking place causes the flow sensor to activate and halt analysis. If the flow sensor is **Off**, opening the iOS System door while analysis is taking place results in air being drawn into the Analyzer.

Using the Super iOS System

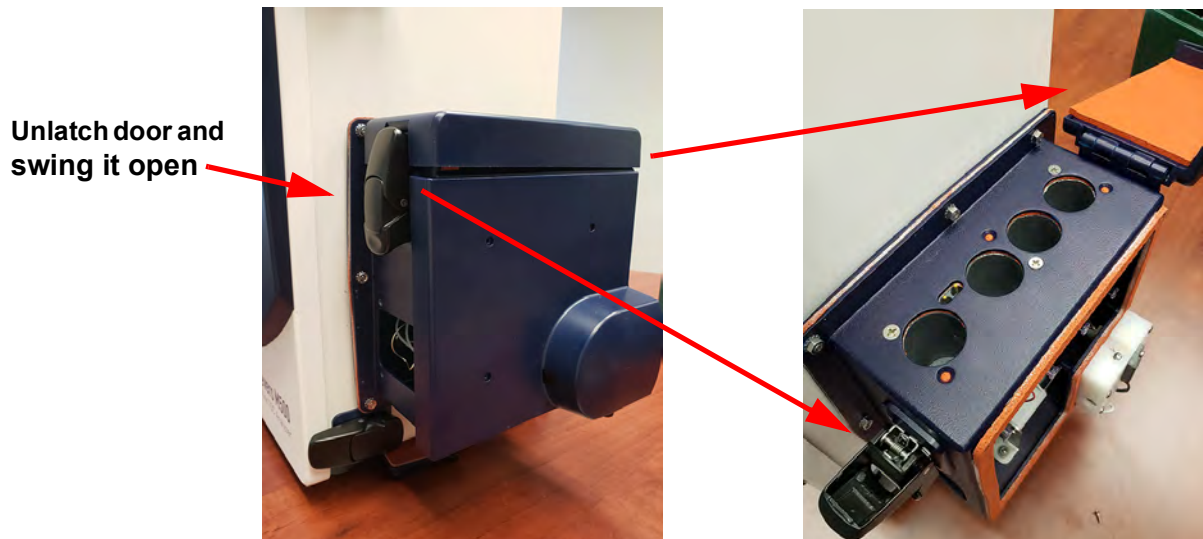

Figure 13: The Super iOS System

Drain the Super iOS for 30 seconds and then insert one to four vials and run a grab method analysis. The Super iOS is also designed with the added convenience of working with Sievers Standards Cartridges (pre-loaded with vials).

VIAL SET CARTRIDGES

The Super iOS is designed to take advantage of Sievers Standards in cartridges. The Analyzer automatically reads certain data from the cartridge, including the following:

- Vial set part number
- Vial set expiration date
- Vial set name
- Vial name
- Vial part number
- Vial lot number
- Vial expiration date

Using the Sample Inlet Block



Figure 14: The Sample Inlet Block

The Sample Inlet Block is designed to for Online sampling only. Sampling from a vial is not possible with this configuration.



NOTE: *The Sample Inlet Block is designed for Online sampling only. Sampling from a vial is not possible with this configuration.*

Warning



The Sample Inlet Block may be hot. If the sample water is hot, be careful to avoiding touching the Sample Inlet Block.







STEAM EXPOSURE

The iOS and Super iOS are rated at IP 55 and can withstand short-term steam exposure of up to 40 psi steam for 30 minutes. When exposed to steam, the Analyzer should be powered off or in standby mode, and not in analysis mode. After exposure to steam, allow the Analyzer to cool before returning to Analysis mode. Observe the following cool-down intervals before starting analysis after steam exposure:

<i>Ambient Temperature</i>	<i>Time Interval</i>
Below 20 °C	15 minutes
20 - 30 °C	30 minutes
30 - 40 °C	90 minutes

THE ANALYZER SCREENS

The Analyzer contains the following screens:

- *Home*  screen
- *Protocols*  screen
- *Settings*  screen
- *Data*  screen
- *DataGuard*  screen
- *Help*  screen

Refer to [“The Analyzer’s Standard Toolbar” on page 121](#) for a high-level description of each screen.



NOTE: If Password Protection or DataGuard is enabled, login is first required before gaining access to screens and starting and stopping analysis. Individual DataGuard UserIDs must also contain the appropriate Access Level for specific screens and functionality access. Refer to [Chapter 5. “Password Protection and DataGuard” on page 191.](#)

Navigating the Analyzer Screens

When the Sievers M500 TOC Analyzer is first powered on, the touchscreen immediately illuminates showing the *Home*  screen. The display changes according to the screen selected from the static *Standard* toolbar (located on the top of the screen).

THE STANDARD TOOLBAR

Use the *Standard* toolbar (located at the top of the Analyzer display) to select and display a new screen. Simply pressing one of the corresponding icons, as described in [Table 5, “The Analyzer’s Standard Toolbar,” on page 121](#). The toolbar remains static as each screen is displayed, providing the ability to easily switch between one screen to another.

Additionally, the *Standard* toolbar includes a field displaying the most recent results measurement ([“Running Online Analysis” on page 131](#)) and the **POWER OFF** button ([“To power off the Analyzer” on page 115](#)). The toolbar may also include an interactive error  icon that indicates the Analyzer has issued a warning or error message. Press this icon for quick access to the *Errors* tab (on the *Settings* screen) for reviewing and acknowledging these warnings and errors. After acknowledging all warnings and errors, the icon clears from the toolbar.

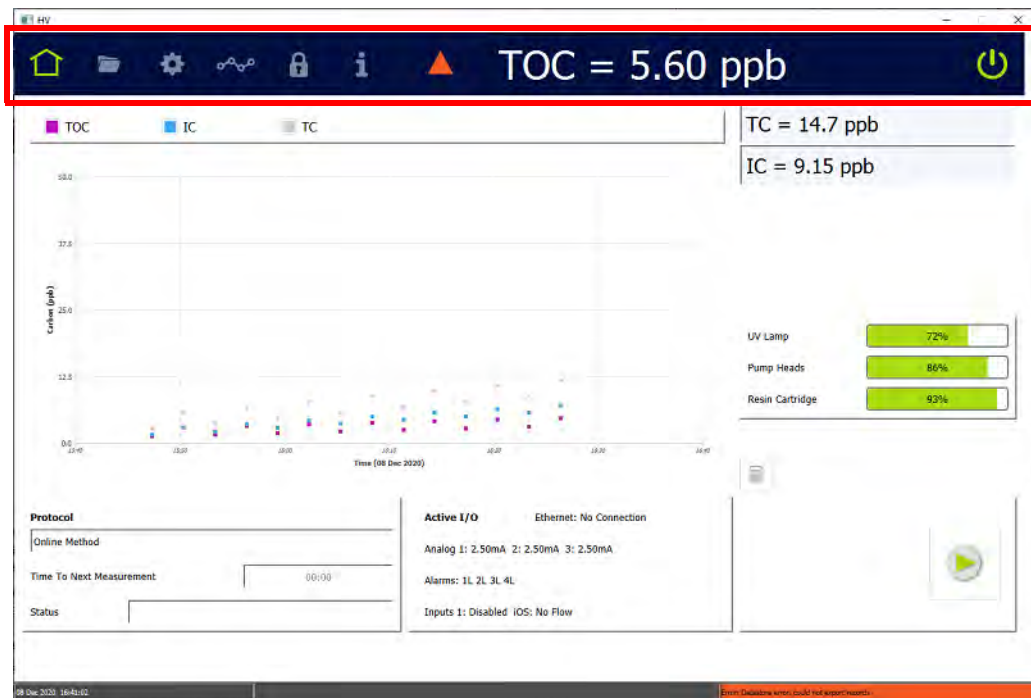

Figure 15: Standard Toolbar

Table 5: The Analyzer’s Standard Toolbar





	<p>HOME (For more screen details, go to page 126.)</p>	<p>Log in (Log out); Start and Stop Analysis; Most Recent Analysis Results (Trend Graph or Details); Error and Warning Indicators; Instrument Power Off (to close files*); Active Measurement Mode (Protocol), Measurement Status; Active I/O; Consumables Status</p> <p>*After closing files, turn the rotary power switch to turn off instrument power.</p>
	<p>PROTOCOLS (For more screen details, go to page 136.)</p>	<p>System Protocols tab Calibration, Verification, Validation (if activated) Protocols</p> <p>User Defined Methods tab User Defined Methods, Active Measurement Mode</p>

Table 5: The Analyzer's Standard Toolbar

	<p>SETTINGS (For more screen details, go to page 137.)</p>	<p>System Setup tab Local Settings Environment (Analyzer Name, Location, Language, Date/Time), Display Formats, Pharmacopoeia, Screen; Result Preferences Result Display, Graph Options; Export Preferences Destination, Format</p> <p>Instrument Settings tab System Constants IC and TC Cell Constants, Thermistor Constants, TOC Calibration Constants, Sample Conductivity Calibration Constants, Model and Serial Number; Analyzer Settings (Scrollable Table); Settings (Export, Print, Import); User TOC Offset; Activations; Upgrade Firmware; Temperature Compensation; Warning/Error Notification</p> <p>Hardware tab Accelerated Rinse, Alarms Setup, Analog Output Calibration, Analog Outputs Setup, Backflush, Binary Inputs Setup, Drain Instrument, Ethernet Setup, Flow Sensor Setup, Flush Super iOS, Instrument Startup Wizard, Level Sensor Setup, Printer Setup, UV Lamp Setup, WiFi Setup</p> <p>Consumables tab UV Lamp, Pump Heads, Resin Cartridge</p> <p>Diagnostics tab System Tests Alarm Test, Analog Output Test, Modbus Test, Network Folder Test, Printer Test, Sample Flow Rate Test, Super iOS Test, IC Power Relay Test, Internet Connection, USB Serial Loopback Test, Serial Loopback Test, WiFi Test, Export Diagnostics, Clean Screen; Service Diagnostics Sample Pump, IC Cell Diagnostic Data, DI Loop, UV Lamp, TC Cell Diagnostic Data, Sample Cell Diagnostic Data; Level 1 Diagnostics</p> <p>Errors tab Acknowledge Error, Print, Export</p> <p>Backup/Restore tab Manual Backup/Restore, Scheduled Backup, Available Backups to Restore, Create Backup, Archive, Restore Backup, Restore Constants</p>
	<p>DATA (For more screen details, go to page 184.)</p>	<p>Online Data tab Print, Export</p> <p>System Protocols and Grab Methods Data tab Print, Export</p>





Table 5: The Analyzer’s Standard Toolbar

	<p>PASSWORD PROTECTION <i>(For more screen details, go to page 189.)</i></p> <p>DATAGUARD <i>(For more screen details, go to page 189.)</i></p>	<p>PASSWORD PROTECTION: Enable Security Password, Password Settings, Enter Password</p> <p>DATAGUARD:</p> <p>User List tab Add User, Edit User, Export User</p> <p>Roles tab Access Levels, Current Roles, All Roles</p> <p>Settings tab Password Settings, User ID Settings</p> <p>Audit Trail tab Export Audit Trail</p>
	<p>HELP <i>(For more screen details, go to page 190)</i></p>	<p>System Information Application Version, Instrument Controller Version, Dual Conductivity Version, Dual Conductivity FPGA Version, Single Conductivity Version, Single Conductivity FPGA Version, Super iOS Version, Operating System Version, WiFi IP Address, Ethernet Address, Key</p>

Printing and Exporting from the Analyzer Screens

Many of the Analyzer screens include **PRINT** and **EXPORT** buttons to work with specifically-selected information, and some screens also include **PRINT ALL** and **EXPORT ALL** buttons.

The Analyzer supports a PDF printer, which must first be connected to the Analyzer (either directly or over an Ethernet network) and enabled in the firmware (*Settings*  screen > *Hardware* tab). For more information, refer to [“Installing an Ethernet Connection \(Optional\)” on page 89](#), [“Configuring an Ethernet Connection” on page 165](#), and [“Enabling a PDF Printer” on page 170](#).

The Analyzer also supports data export to a USB memory device or to a network, according to the settings defined in the firmware. Review these Analyzer settings, which are located on the *Export Preferences Panel* (*Settings*  screen > *Instrument Settings* tab). For more information, refer to [“Configuring Export Preferences” on page 145](#).

To print from an Analyzer screen

1. Verify that the screen includes a **PRINT** (or **PRINT ALL** or **PRINT SETTINGS** or **PRINT TABLE**) button.
2. Ensure a PDF printer is connected to the Ethernet port (either directly or over a network) and the PDF printer is enabled in the firmware. (For information, see [“Enabling a PDF Printer” on page 170](#).)
3. Do one of the following:
 - If there is more than one item available to print (such as a table of records or panel of Protocol methods), select the record to print and press **PRINT**.

Chapter 4 BASIC ANALYZER OPERATION

- If an option to print all records associated with the screen is available, press the applicable button, such as **Print All** or **Print Settings** or **Print Table**.

The Analyzer prints to the connected and enabled PDF printer.

To export from an Analyzer screen

1. Verify that the screen includes an **EXPORT** (or **EXPORT ALL** or **EXPORT SETTINGS** or **EXPORT TABLE**) button.
2. If needed, refer to the Export settings on the *Export Preferences* panel to identify the export destination (USB memory device or network) and other settings. For more information, refer to [“Configuring Export Preferences” on page 145](#)).
3. If using a USB memory device for the export, insert it into the USB port.
4. Do one of the following:
 - If more than one item is available to export (such as a table of records or panel of Protocol methods), select the record to export and press **EXPORT**.
 - If an option to export all records associated with the screen is available, press the applicable button, such as **Export All** or **Export Settings** or **Export Table**.

The *Export* screen appears.

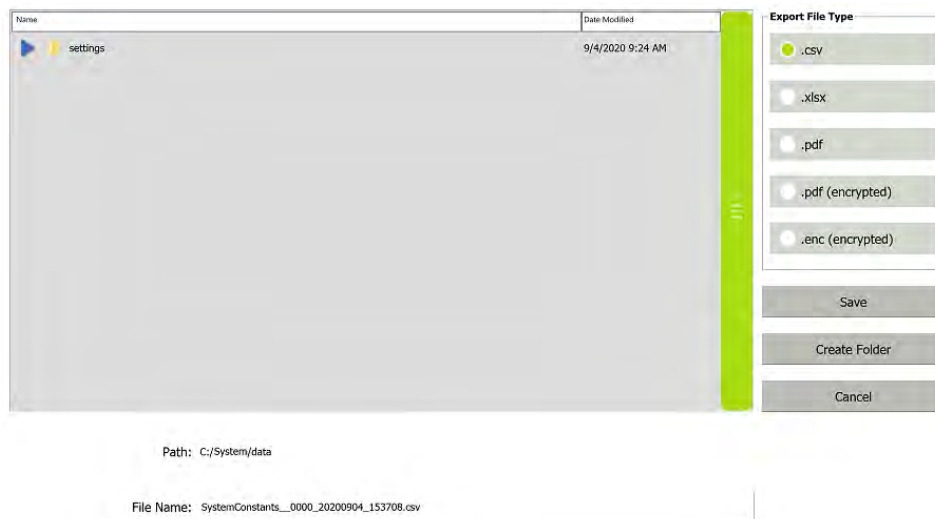

5. In the *Export File Type* area, leave the default type(s) or select one or more of the following:
 - .csv
 - .xlsx
 - .pdf



- .pdf (encrypted)

The password required to open the PDF file is specified on the *Export Preferences* panel. See [“Configuring Export Preferences” on page 145.](#)

- .enc (encrypted)
- [Chapter 4. "Basic Analyzer Operation."](#)

6. Leave the default destination or add a folder to it by pressing the **CREATE FOLDER** button. Use the alphanumeric keypad to type a folder name and press **OK**. The Analyzer adds the folder to the export path configured on the *Export Preferences* panel, and displays the folder in the *Path* field and in the **Name** area.



NOTE: *The export path represents the default destination of USB memory device or a network location, as configured on the Export Preferences panel. To revise the default destination, see [“Configuring Export Preferences” on page 145.](#)*

7. Leave the default file name or press inside the *File Name* field. Use the alphanumeric keypad to type a new file name (but not a file type extension) and press **OK**. The exported file(s) are assigned the file type extension(s) selected in step 5.)
8. In the **Name** area, select the folder to receive the exported file and press **SAVE**. An export completed confirmation message appears.
9. Press **OK** to confirm and close the message.
10. If a USB memory device was used, remove it for safe keeping.

THE HOME SCREEN

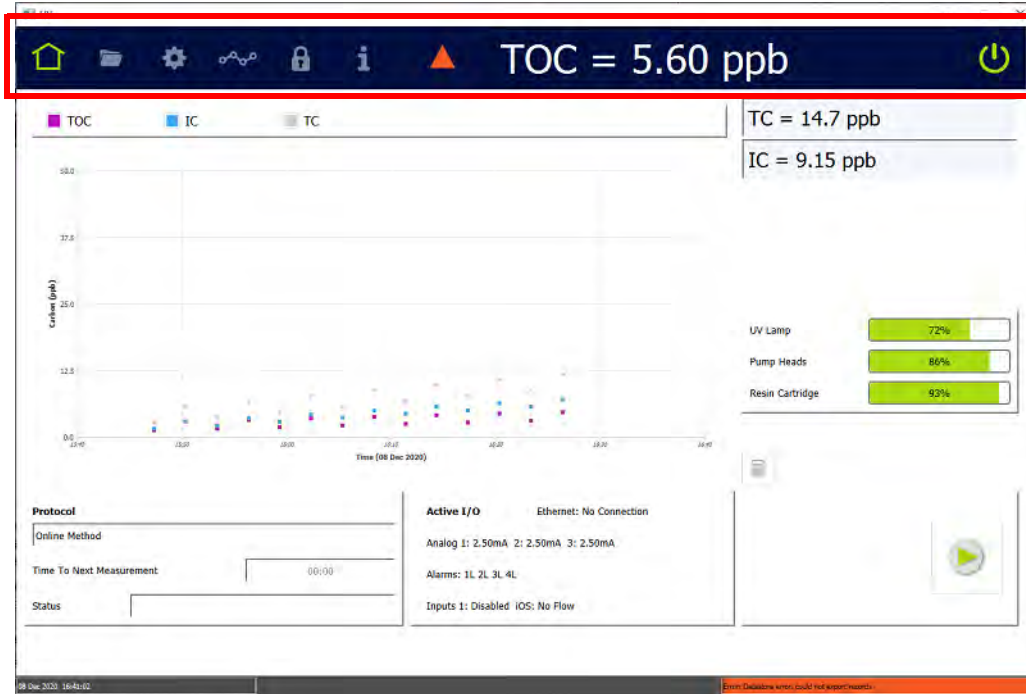

Figure 16: The Home Screen

Use the *Home* screen to *Start Analysis* and *Stop Analysis* , as well as monitor real-time results data in a *Trend Graph* or *Details Table* format

To change the trend graph settings, including which values are displayed (Carbon [TOC, IC, TC], Conductivity [if Sample Conductivity is enabled], and/or Temperature), the time range on the X axis, and the minimum and maximum values on the Y axis, see [“Setting Trend Graph Display Options” on page 141](#). To change the time range on the X axis, the background color, and the size of the data points, see [“To change the display of data on the trend graph” on page 127](#).





The most recent TC and IC data appears on the screen under the static Standard Toolbar (that shows the most recent TOC analysis result). This toolbar may also show an interactive error icon to indicate when the Analyzer has issued a warning or error message. (For more information on the toolbar, see [“The Standard Toolbar” on page 120](#).)

The *Home* screen also includes a section showing the active Analyzer mode (Protocol), along with its status (*Initializing*, *Analyzing*, and so on) and the time remaining until the next measurement. To modify the default Analyzer mode, see [“Setting the Measurement Mode” on page 128](#).



Additionally, the *Active I/O* settings and consumables usage (% used) indicators (UV Lamp, Pump Heads, and Resin Cartridge) appear on the *Home* screen.

To change the display of data on the trend graph

Use this procedure to change the background color and the size of the data points on the trend graph. The changes to the trend graph appear on both the *Home*  screen and the *Online Data* tab of the *Data*  screen. You can also change the time range on the X axis of the trend graph on the *Home*  screen. (The trend graph on the *Online Data* tab of the *Data*  screen has its own options for setting the time range on the X axis.)

1. Press anywhere on the trend graph. A *Chart* dialog box appears.

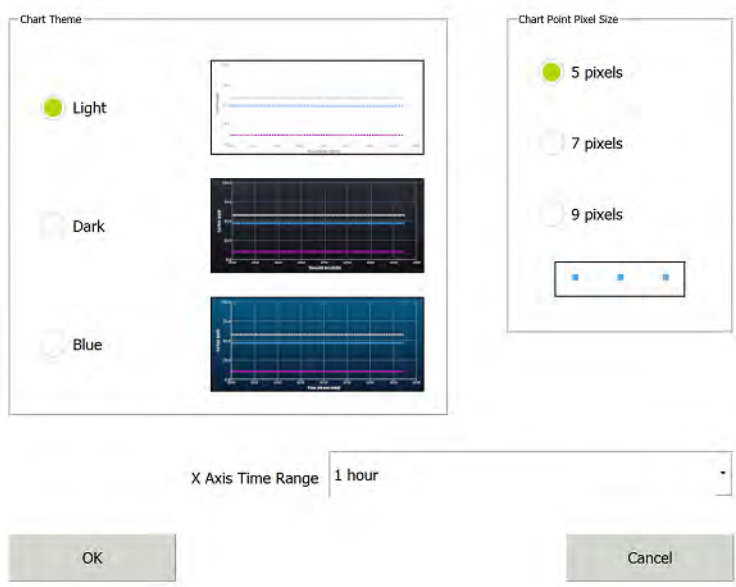

2. To change the color of the trend graph background, select a chart theme: *Light* (white background), *Dark* (black background), or *Blue* (blue background).
3. To change the size of the data points on the trend graph, select *5 pixels*, *7 pixels*, or *9 pixels*. When you make a selection, the size of the three data points in the rectangular box changes to match the selection.
4. To change the time range on the trend graph, press within the *X Axis Time Range* field and select a value: **1 hour**, **4 hours**, **8 hours**, **12 hours**, **1 day**, **3 days**, or **1 week**.



NOTE: Changing the value for the time range on the X axis here also changes the value for the time range on the *Result Preferences* panel (*Settings*  screen > *System Setup* tab). In a like manner, changing the value for the time range on the *Result Preferences* panel also changes the value here. See [“To set trend graph display options” on page 141.](#)

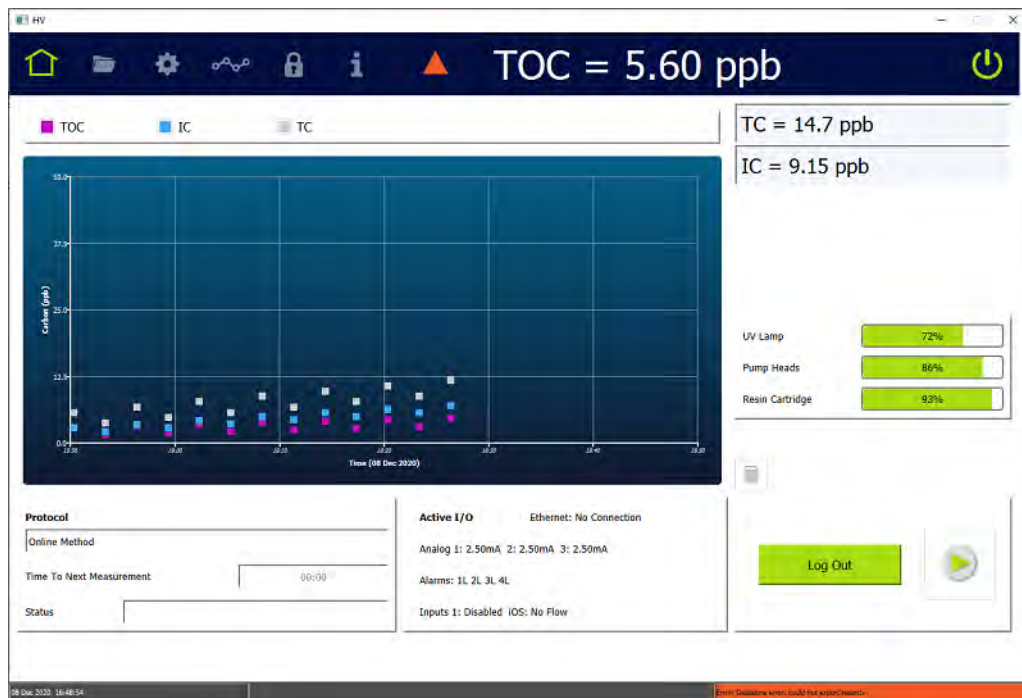

Chapter 4 BASIC ANALYZER OPERATION

5. Press **OK**. The trend graph reappears with the selected time range, background, and point size. The example shows a trend graph with a time range of 1 hour, a blue background, and 9-pixel data points.



Setting the Measurement Mode

The Sievers M500 TOC Analyzer provides three different *Online* modes for running the Analyzer with a continuous water source. A *Grab* mode is also available for sampling from a vial in the Analyzer's Standard iOS or Super iOS System.

Select one of these modes as the default measurement mode using the *Protocols*  screen. The Analyzer uses this measurement mode setting for analysis started from the *Home*  screen (which also displays the active measurement mode in the *Protocols* field).

To revise the active measurement mode

1. On the *Protocols*  screen, select the *User Defined Method* tab.

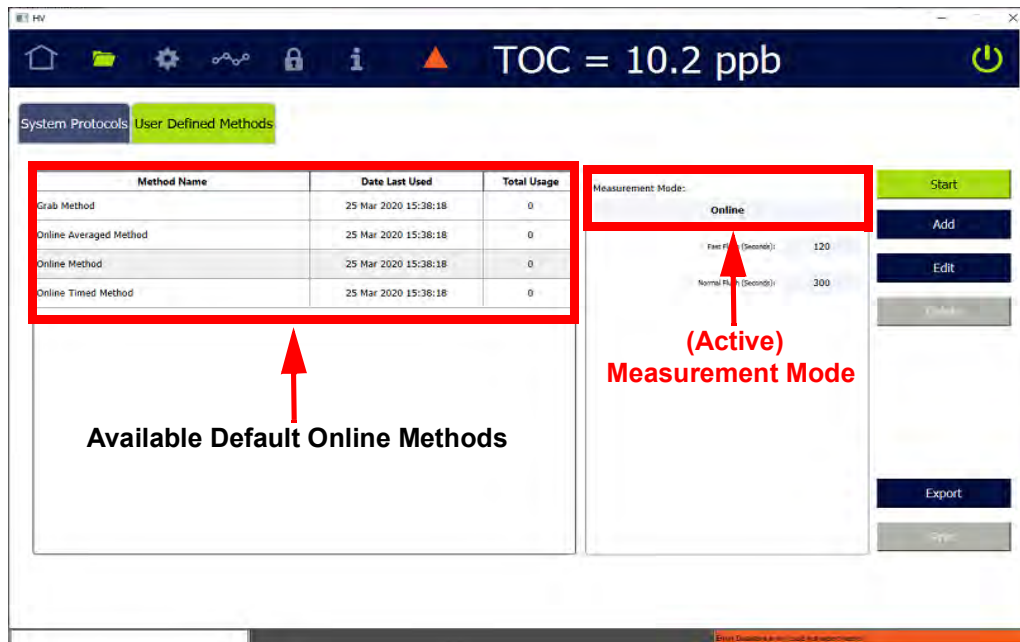

2. On the *Measurement Mode* panel (located on the right), verify the mode (method) appearing in the *Measurement Mode* field. Leave this mode or select one of the following from the *Method Name* table (located on the left):

- ONLINE METHODS (Select one.)
 - *Online* method — The Analyzer measures TOC continuously and returns measurement results every three minutes (with option) or six minutes (with base model).
 - *Online Timed* method — The Analyzer returns a single TOC measurement at specified times of the day.
 - *Online Averaged* method — The Analyzer returns the averaged value of TOC over a specific time interval.

The selected method appears as the measurement mode in the *Measurement Mode* field (on the *Measurement Mode* panel). Go to step [9](#).

- GRAB METHOD
 - *Grab* Method — The Analyzer performs analyses by drawing samples from a vial (placed in the designated vial port) in the Analyzer’s iOS or Super iOS System. (Grab mode is not available for configurations with the Sample Inlet Block.)



NOTE: When measuring in Grab mode and using glass vials, the sample water must be acidified to a pH of three (3). If using plastic vials, no acidification is required.

The selected method appears in the *Measurement Mode* field (on the *Measurement Mode* panel). Go to step [3](#).

Chapter 4 BASIC ANALYZER OPERATION

3. With *Grab* Method selected, leave the default parameters shown on the *Measurement Mode* panel or press **EDIT**. The *Edit Method* screen appears.

The screenshot shows the 'Edit Method' window with the following details:

- Measurement Mode: **Grab**
- Method Name: **Grab Method**
- Start Online When Done:
- Number Of Vials: **1**
- Fast Flush (Seconds): **120**
- Normal Flush (Seconds): **300**
- Vial Position 1: Sample Name: **Sample 1**, Vial Type: **Sample Vial**, Number of Repetitions: **4**, Number of Rejects: **1**
- Vial Position 2: Sample Name: **Sample 1**, Vial Type: **Sample Vial**, Number of Repetitions: **4**, Number of Rejects: **1**
- Vial Position 3: Sample Name: **Sample 1**, Vial Type: **Sample Vial**, Number of Repetitions: **4**, Number of Rejects: **1**
- Vial Position 4: Sample Name: **Sample 1**, Vial Type: **Sample Vial**, Number of Repetitions: **4**, Number of Rejects: **1**

4. Press inside the *Method Name* field and use the alphanumeric keypad to enter a new name.
5. Select or de-select the *Start Online When Done* option.
6. If using a Standard iOS System, the number in the *Number of Vials* field is 1. Continue to the next step.

If using a Super iOS System, press inside the *Number of Vials* field and use the numeric keypad to enter the number of vials (1- 4). The Analyzer activates a column of fields (*Sample Name*, *Vial Type*, *Number of Repetitions*, *Number of Rejects*) for each vial position.

7. Complete the following:
 - Fast Flush (Seconds) — Press inside the field and use the alphanumeric keypad to enter the number of seconds for a fast flush (120-600).
 - Normal Flush (Seconds) — Press inside the field and use the alphanumeric keypad to enter the number of seconds for a normal flush (300-1500).
8. Complete the following for each vial position:
 - Sample Name — Press inside the field and use the alphanumeric keypad to enter a name.
 - Vial Type — Select one of the following: *Sample Vial*, *Blank Vial*, *Standard Vial*, *Rinse Vial*.
 - Number of Repetitions — Press inside the field and use the numeric keypad to enter the number of replicate TOC measurements for the Analyzer to perform on the sample.

- Number of Rejects — Press inside the field and use the numeric keypad to enter the number of replicate TOC measurements for the Analyzer to perform.



NOTE: Using at least four (4) repetitions allows rejection of the first value and calculation of a standard deviation using the remaining values.

9. Setting the measurement mode is complete and this measurement mode now appears in the *Protocols* field on the *Home* screen. The Analyzer automatically uses this measurement mode for analysis initiated with the **START ANALYSIS** button.

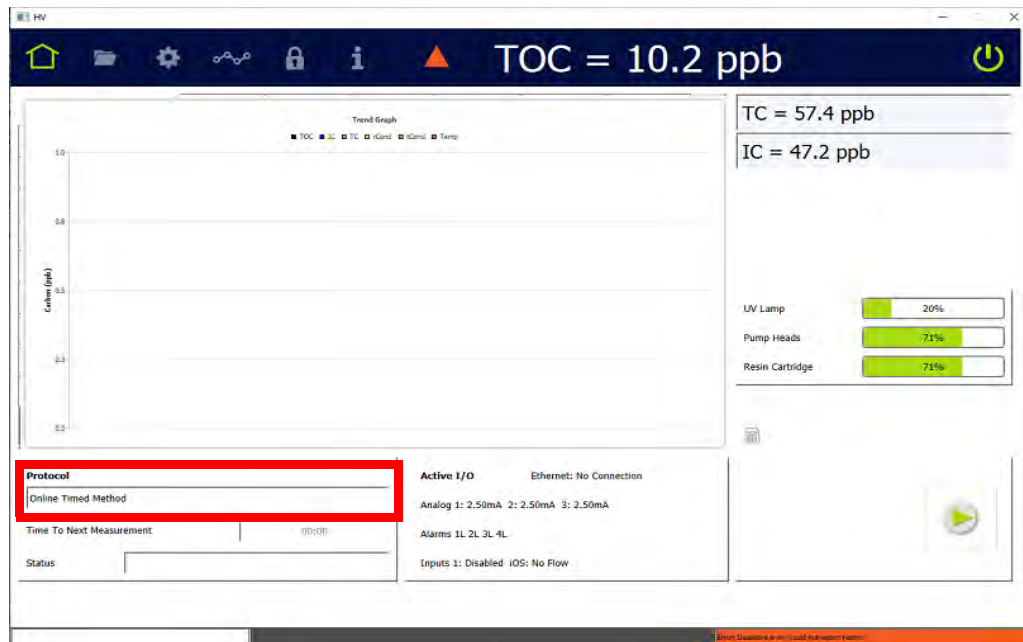

NOTE: When the Analyzer is running system protocols and Grab methods, the Home screen displays TOC, IC, and TC values for each repetition with average, standard deviation, and relative standard deviation when all repetitions for a vial have been run. The Trend Graph is not available for system protocols and Grab methods. See [“To run a grab sample” on page 132](#).

Running Online Analysis

Use the *Home* screen to start and stop online analysis using a continuous water source. Simply press *Start Analysis* and *Stop Analysis* . The Analyzer automatically uses the active online measurement mode appearing in the *Protocol* field. For more information about available online measurement modes or to change the measurement mode, refer to [“Setting the Measurement Mode” on page 128](#).

Chapter 4 BASIC ANALYZER OPERATION

Alternatively, online analysis can be started from the *User Defined Methods* tab on the *Home* screen.

Running a Grab Sample

Use the *Home*  screen to perform a grab sample analysis using a vial inserted in a Standard iOS or Super iOS. (Grab sampling is not available for configurations with the Sample Inlet Block.)

Alternatively, grab samples can be started from the *User Defined Methods* tab on the *Home* screen.



NOTE: When measuring in Grab mode and using glass vials, the sample water must be acidified to a pH of three (3). If you are using plastic vials, no acidification is required.

To run a grab sample

1. On the *Home*  screen, verify that a *Grab* method (measurement mode) appears in the *Protocol* field.

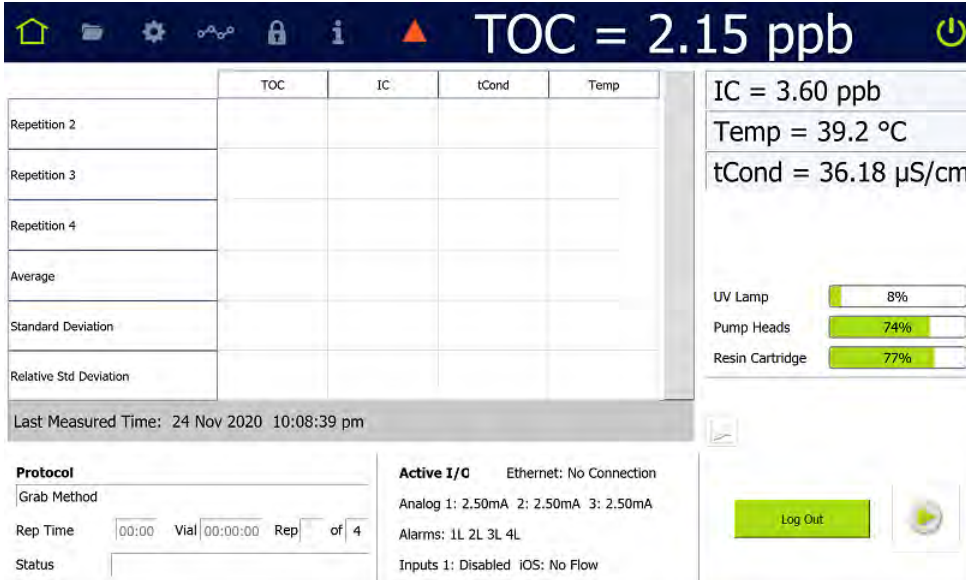

The screenshot displays the TOC analyzer's home screen. At the top, a dark blue header shows the current TOC reading as 2.15 ppb. Below this is a table with columns for TOC, IC, tCond, and Temp, and rows for Repetition 2, Repetition 3, Repetition 4, Average, Standard Deviation, and Relative Std Deviation. To the right of the table, a panel shows IC = 3.60 ppb, Temp = 39.2 °C, and tCond = 36.18 µS/cm. Below this, three progress bars indicate the status of the UV Lamp (8%), Pump Heads (74%), and Resin Cartridge (77%). At the bottom, a 'Protocol' section shows 'Grab Method' selected, and a 'Status' section shows 'Active I/O' as 'Ethernet: No Connection' and 'Inputs 1: Disabled iOS: No Flow'. A 'Log Out' button is visible in the bottom right corner.

2. If using a Standard iOS System, insert the sampling vial into the vial port, and then go to step 4. Otherwise, if using a Super iOS System, continue to the next step.
3. If using a Super iOS System, before proceeding you will need to know the number of vial positions in this Grab method (*Protocols* screen > *User Defined Method* tab).
4. Press *Start Analysis*  .



- If the Sample Conductivity option is enabled, the *Conductivity Temperature Compensation* dialog box appears. Continue to the next step.
- If the Sample Conductivity option is not enabled and you are using a Super iOS System, the *Drain Super iOS* dialog box appears. Go to step [6](#).
- If the Sample Conductivity option is not enabled, and you are using a Standard iOS System, the Analyzer begins analysis of the sample according to the method selected for the protocol. Go to step [15](#).



NOTE: A grab sample can also be started on the *User Defined Method* tab. With the *Grab* method selected in the *Measurement Mode* field, press **START**. Pressing **START** is like pressing *Start Analysis*  on the *Home*  screen. See step [4](#).

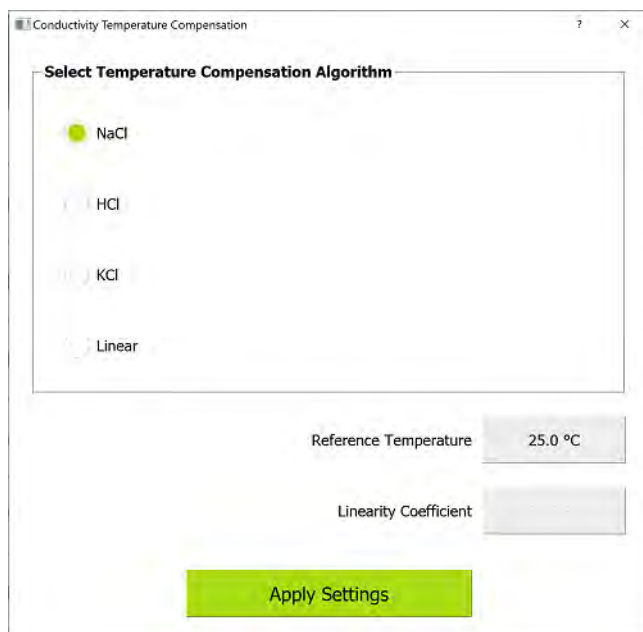

5. Select the *Temperature Compensation Algorithm* and enter values as needed for the *Reference Temperature* and *Linearity Coefficient* (if *Linear* is the algorithm). For more information, see [“Setting Conductivity Temperature Compensation” on page 153](#). When you finish, press **APPLY SETTINGS**.

If using a Super iOS System, the *Drain Super iOS* dialog box appears. Go to step [6](#).

If using a Standard iOS System, the The Analyzer begins analysis of the sample according to the method selected for the protocol. Go to step [15](#).

Chapter 4 BASIC ANALYZER OPERATION

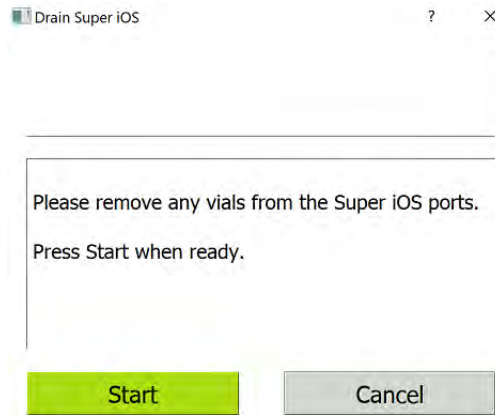

6. Ensure the Super iOS System is empty of any vials and open the iOS door.
7. Press **START**. The system drains the iOS, and the *Drain Super iOS* dialog box displays a count-down timer to drain completion.

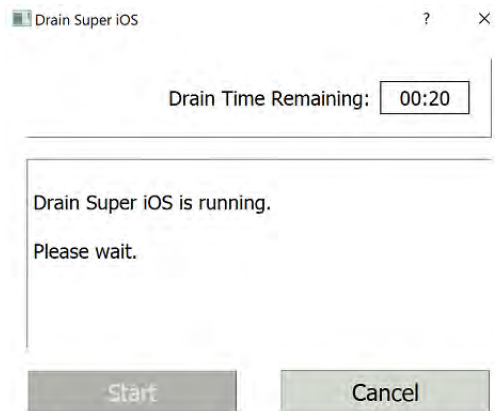

8. When the drain is complete, press **CLOSE**. The *Select Rinse Super iOS option* dialog box appears.

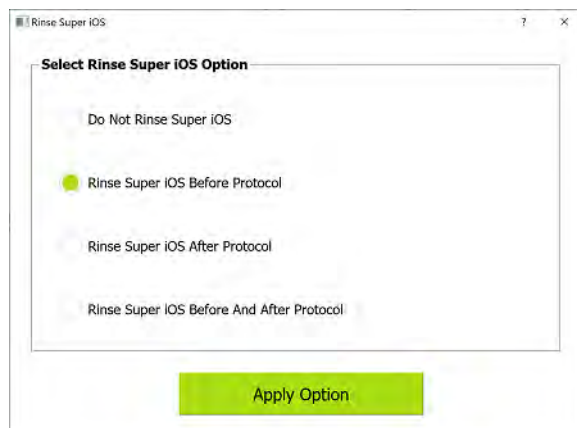

9. Select one of the following rinse options and press **APPLY OPTION**:



- Do Not Rinse Super iOS
- Rinse Super iOS Before Protocol
- Rinse Super IOS After Protocol
- Rinse Super iOS Before and After Protocol

10. If *Rinse Super iOS Before Protocol* or *Rinse Super iOS Before and After Protocol* was selected, the *Super iOS Rinse* dialog box appears. Otherwise, if *Do Not Rinse Super iOS* or *Rinse Super IOS After Protocol* was selected, go to step [13](#).

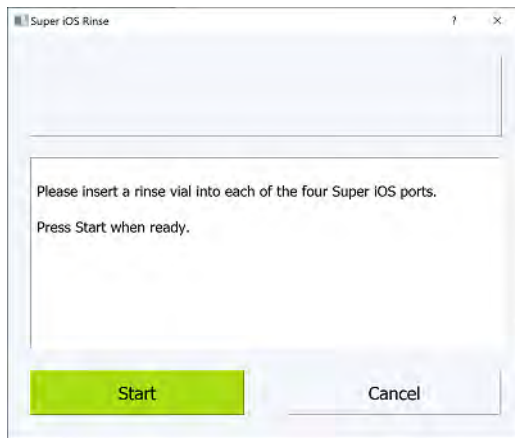

11. Insert a rinse vial into each of the four Super iOS ports and press **START**. The *Super iOS Rinse* dialog box displays a count-down timer and automatically closes upon completion.

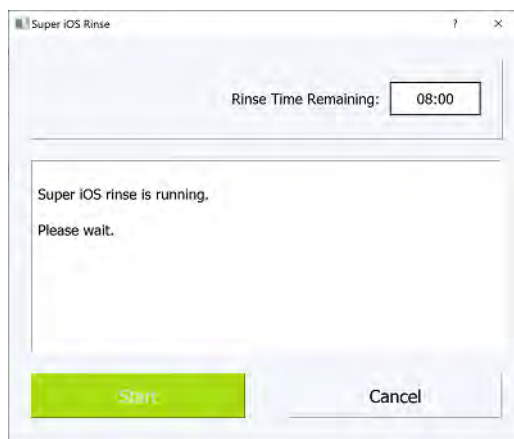

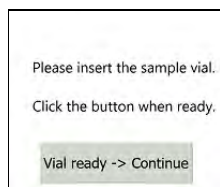

12. After the completion of the rinse, the *Please insert the sample vials....* dialog box appears.

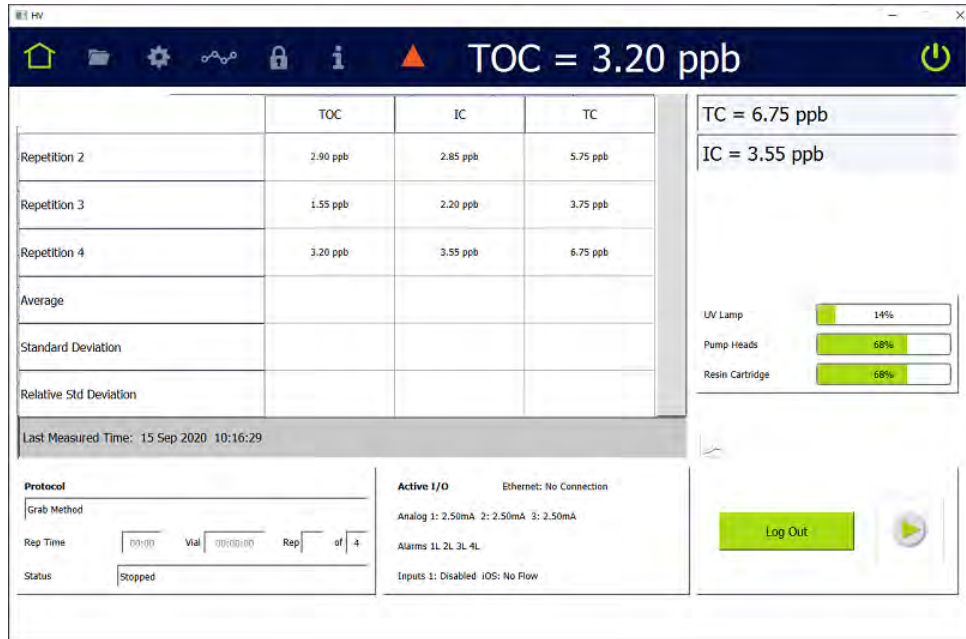

Chapter 4 BASIC ANALYZER OPERATION

13. Insert a sample vial in each vial position (Vial Position 1, Vial Position 2, Vial Position 3, and/or Vial Position 4), as defined in the *Grab* protocol.
14. Press **VIALS READY>CONTINUE**. The Analyzer performs an analysis of each vial reporting protocol status of each vial and the most recent sampling results on the screen.
15. After the Analyzer completes analysis, **Stopped** appears in the *Status* field.



16. To view complete details, review the data history (*Data*  screen > *System Protocols and Grab Methods Data* tab). For additional information, refer to [“To review data history for System Protocols and Grab Methods” on page 188](#).

THE PROTOCOLS SCREEN



This screen includes System Protocols and User-Defined Methods. For more information about using this screen, see [Calibration and System Protocols on page 213](#).

THE SETTINGS SCREEN



SETTINGS SCREEN — SYSTEM SETUP TAB

Configuring Local Settings

This section includes instructions for configuring settings for the local environment and display formats.

To configure the environment settings

Define the Analyzer name and location, service provider, and system language, or leave the default values. Also, use this instruction to set the system clock.

1. On the *Settings*  screen, select the *System Setup* tab.

2. On the *Local Settings* panel (in the *Environment* section), press inside any of the following fields to use the alphanumeric keypad to specify an identifier and press **OK**.
 - Analyzer Name
 - Location
 - (Optional) Service Provider

3. Press the *Date* field and use the calendar to enter the current month, day, and year.
4. Press the *Time* field and use the numeric keypad to enter the hours, minutes, and seconds (hh:mm:ss).
5. If *Display Format* is set for 12 Hour, select the *am* or *pm* option and press **OK**.
6. Scroll and select an option in the *Time Zone* list.
7. (Optional) Select (green box) or de-select (no green highlight in box) *Internet Time Sync* [Automatically synchronizes the local computer time with the operating system's network time protocol (NTP) server].
8. Continue to the ["To configure the display format settings" on page 138](#).

To select a new display language (Optional)

The Analyzer is shipped from the factory with English as the default language on the Analyzer screens. Use this instruction to change the display language to Chinese (Simplified) or Japanese, as needed.

1. Navigate to the *Local Settings* panel (*Settings*  screen > *System Setup* tab).
2. In the *Environment* area, select the Analyzer's display language from the *Language* list:
 - English
 - Chinese (Chinese Simplified)
 - Japanese
3. Stop any current analysis and power cycle the Analyzer for the new language to take effect.



NOTE: If the program language is changed inadvertently and/or there is a need to switch between language, refer to the following section for help in navigating, ["Problems Changing the Program Language" on page 380](#).

To configure the display format settings

Configure the settings for the date format, the clock format, and number format for display.

1. On the *Settings*  screen, select the *System Setup* tab.
2. On the *Local Setting* panel, under *Display Formats*, select one of the following format options from the *Date* list:
 - Text Based — DD/MM/YYYY (16 jan 2019)

- Month First — MM/DD/YYYY (01/15/2019)
- Day First — DD/MM/YYYY (15/01/2019)
- Year First — YYYY/MM/DD (2019/01/16)

The screenshot shows the 'Local Settings' interface for the Sievers M500 TOC Analyzer. At the top, a status bar displays 'TOC = 10.2 ppb'. Below this is a navigation menu with tabs: System Setup (selected), Instrument Settings, Hardware, Consumables, Diagnostics, Errors, and Backup/Restore. The 'Local Settings' panel is divided into several sections:

- Environment:** Analyzer Name (M500), Location (Boulder), Service Provider, Language (English), Date (06 Nov 2020), Time (14:46:34), Time Zone (America/Denver), and Internet Time Sync.
- Display Formats:** Time format selection (12 Hour (am/pm) and 24 Hour), Date format (16 Jan 2019 (Text Based)), and Numbers format (123,456,789.00).
- Screen:** Screensaver Enabled checkbox and a Wait time field.
- Pharmacopoeia:** Radio buttons for CP, EP, IP, JP, KP, and USP. There are also checkboxes for Water For Injection and Purified Water. Action buttons for View Table, Export Table, and Print Table are present.

Below the main settings are expandable sections for Result Preferences and Export Preferences.

3. Select the *12 hour am/pm* or *24 hour* (24-hour clock format, such as 13:22) option to designate the time format.
4. Select one of the following format options from the *Numbers* list:
 - 123,456,789.00
 - 123.456.789,00

To enable screen features

1. Navigate to the *Local Settings* panel (*Settings*  screen > *System Setup* tab).
2. In the *Screen* area, select or de-select the following:
 - Screensaver Enabled — Select this option and press the *Wait* field to use the numeric keypad to set the number of idle minutes before the Analyzer initiates a screensaver.
 - Warning Notification Disabled — Select this option to disable the screen notification of all warnings (no dialog box message, no yellow triangle at the top of the screen, and no warning text on the lower-right screen). Error History records, alarms, and analog outputs are independent of this setting and will still occur.

Configuring Result Preferences

Use the *Result Preferences* panel to select the results data, from online analysis and grab sampling, to appear on the *Home*  screen and *Data*  screen (data history). The panel also includes *Trend Graph Display* options.

Also, use this panel to set the Analyzer to automatically print results specific to *Grab* Protocols, *System* Protocols or *Online* modes. The frequency can be set to every hour, every 2 hours, every 4 hours, or every 8 hours.

To configure result preferences

1. Navigate to the *Configuring Result Preferences* panel (*Settings*  screen > *System Setup* tab).
2. In the *Rejected Repetitions* area, select or de-select whether to include rejected repetitions in one or more of the following:
 - View (on the Analyzer)
 - Print
 - Export
3. In the *Result Display Options (Enabled Columns)* area, select or de-select which of the following columns to include (The conductivity fields only appear if the Analyzer is configured with the *Sample Conductivity* option.):
 - TOC
 - IC
 - TC
 - rCond
 - tCond
 - temp
 - Pharmacopeia pass/fail (Appears only if a pharmacopeia monograph is enabled.)
4. In the *Automatically Print Results* area, select one or more to automatically print results:
 - Grab Protocols
 - System Protocols
 - Online Modes (If selected, also select one of the following options from the *Automatically Print Results* list: **every sample, every hour, every 2 hours, every 4 hours, every 8 hours.**)

Setting Trend Graph Display Options

Set the time scale and which data appears on the trend graph, which is available for viewing on the *Home*  screen and *Data*  screen. Rejected Repetitions can also be set whether to appear in printed and exported results.

To set trend graph display options

1. Navigate to the *Result Preferences* panel (*Settings*  screen > *System Setup* tab).
2. In the *Trend Graph Display Options* area, configure the following:
 - *X Axis Time Range* list — Select one of the following options from the list: **1 hour**, **4 hours**, **8 hours**, **12 hours**, **1 day**, **3 days**, or **one week**.
 - *Y Axis Scaling* — Select **Auto** (using default minimum and maximum values) or **Manual** (to set the minimum and maximum values).
 - *Y1 Axis* — Select or de-select whether to include **Carbon (TOC, IC, TC)**. If the *manual Y-Axis scaling* option was previously selected, press inside each of the *Min* and *Max* fields and use the alphanumeric keypad to set the minimum and maximum value (TOC values in ppb or conductivity values in $\mu\text{S/cm}$).
 - *Y2 Axis* — Select or de-select whether to enable **Conductivity**. If the *manual Y-Axis scaling* option was previously selected, press inside each of the *Min* and *Max* fields and use the alphanumeric keypad to set the minimum and maximum value (TOC values in ppb or conductivity values in $\mu\text{S/cm}$).
 - *Y3 Axis* — Select or de-select whether to include **Temperature**. If the *manual Y-Axis scaling* option was previously selected, press inside each of the *Min* and *Max* fields and use the alphanumeric keypad to set the minimum and maximum value (TOC values in ppb or conductivity values in $\mu\text{S/cm}$).

Specifying the Pharmacopoeia

Because pharmacopoeia TOC and conductivity monographs diverge, the Analyzer allows you to specify which pharmacopoeia monograph is applicable to your environment. This section includes instructions for specifying the pharmacopoeia to apply to the sample analyses.

You can also use the Analyzer without selecting a pharmacopoeia. Refer to [“Pharmacopoeia Options” on page 144](#) for pharmacopoeia descriptions.

Chapter 4 BASIC ANALYZER OPERATION

To specify the pharmacopoeia monograph (optional)

1. Navigate to the *Local Settings* panel (*Settings*  screen > *System Setup* tab).
2. In the Pharmacopoeia area, select one or more of the following pharmacopoeia options. Or, to use the Analyzer without selecting a pharmacopoeia, de-select **all** of the options.
 - CP
 - JP
 - EP
 - KP
 - IP
 - USP

For information on each option and pass/fail reporting, refer to [“Working with Pharmacopoeia Monographs” on page 143.](#)

3. Select either the *Water For Injection* option or the *Purified Water* option.
4. To view or export the Stage 1 Conductivity table(s), press **VIEW TABLE**.

	CP WF1 Conductivity	CP PW Conductivity	EP WF1 4.8 Conductivity	EP PW 4.8 Conductivity	IP WF1 Conductivity	IP PW Conductivity	JP 6.8 Conductivity	USP 645 Conductivity
0.00 °C	0.600 µS/cm	2.400 µS/cm	0.600 µS/cm	2.400 µS/cm	0.600 µS/cm	2.400 µS/cm	0.600 µS/cm	0.600 µS/cm
5.00 °C	0.800 µS/cm	3.200 µS/cm	0.800 µS/cm	3.200 µS/cm	0.800 µS/cm	3.200 µS/cm	0.800 µS/cm	0.800 µS/cm
10.00 °C	0.900 µS/cm	3.600 µS/cm	0.900 µS/cm	3.600 µS/cm	0.900 µS/cm	3.600 µS/cm	0.900 µS/cm	0.900 µS/cm
15.00 °C	1.000 µS/cm	4.000 µS/cm	1.000 µS/cm	4.000 µS/cm	1.000 µS/cm	4.000 µS/cm	1.000 µS/cm	1.000 µS/cm
20.00 °C	1.100 µS/cm	4.300 µS/cm	1.100 µS/cm	4.300 µS/cm	1.100 µS/cm	4.300 µS/cm	1.100 µS/cm	1.100 µS/cm
25.00 °C	1.200 µS/cm	5.100 µS/cm	1.300 µS/cm	5.100 µS/cm	1.300 µS/cm	5.100 µS/cm	1.300 µS/cm	1.300 µS/cm
30.00 °C	1.400 µS/cm	5.400 µS/cm	1.400 µS/cm	5.400 µS/cm	1.400 µS/cm	5.400 µS/cm	1.400 µS/cm	1.400 µS/cm
35.00 °C	1.500 µS/cm	6.000 µS/cm	1.500 µS/cm	6.000 µS/cm	1.500 µS/cm	6.000 µS/cm	1.500 µS/cm	1.500 µS/cm
40.00 °C	1.700 µS/cm	6.500 µS/cm	1.700 µS/cm	6.500 µS/cm	1.700 µS/cm	6.500 µS/cm	1.700 µS/cm	1.700 µS/cm
45.00 °C	1.800 µS/cm	7.000 µS/cm	1.800 µS/cm	7.000 µS/cm	1.800 µS/cm	7.000 µS/cm	1.800 µS/cm	1.800 µS/cm
50.00 °C	1.900 µS/cm	7.100 µS/cm	1.900 µS/cm	7.100 µS/cm	1.900 µS/cm	7.100 µS/cm	1.900 µS/cm	1.900 µS/cm
55.00 °C	2.100 µS/cm	7.500 µS/cm	2.100 µS/cm	7.500 µS/cm	2.100 µS/cm	7.500 µS/cm	2.100 µS/cm	2.100 µS/cm
60.00 °C	2.200 µS/cm	8.100 µS/cm	2.200 µS/cm	8.100 µS/cm	2.200 µS/cm	8.100 µS/cm	2.200 µS/cm	2.200 µS/cm
65.00 °C	2.400 µS/cm	8.400 µS/cm	2.400 µS/cm	8.400 µS/cm	2.400 µS/cm	8.400 µS/cm	2.400 µS/cm	2.400 µS/cm
70.00 °C	2.500 µS/cm	9.100 µS/cm	2.500 µS/cm	9.100 µS/cm	2.500 µS/cm	9.100 µS/cm	2.500 µS/cm	2.500 µS/cm
75.00 °C	2.700 µS/cm	9.700 µS/cm	2.700 µS/cm	9.700 µS/cm	2.700 µS/cm	9.700 µS/cm	2.700 µS/cm	2.700 µS/cm
80.00 °C	2.700 µS/cm	9.700 µS/cm	2.700 µS/cm	9.700 µS/cm	2.700 µS/cm	9.700 µS/cm	2.700 µS/cm	2.700 µS/cm
85.00 °C	2.700 µS/cm	9.700 µS/cm	2.700 µS/cm	9.700 µS/cm	2.700 µS/cm	9.700 µS/cm	2.700 µS/cm	2.700 µS/cm
90.00 °C	2.700 µS/cm	9.700 µS/cm	2.700 µS/cm	9.700 µS/cm	2.700 µS/cm	9.700 µS/cm	2.700 µS/cm	2.700 µS/cm
95.00 °C	2.900 µS/cm	9.900 µS/cm	2.900 µS/cm	9.900 µS/cm	2.900 µS/cm	9.900 µS/cm	2.900 µS/cm	2.900 µS/cm
100 °C	3.100 µS/cm	10.20 µS/cm	3.100 µS/cm	10.20 µS/cm	3.100 µS/cm	10.20 µS/cm	3.100 µS/cm	3.100 µS/cm

Close

5. To print the *Stage 1 Conductivity* table, ensure a PDF printer is connected to the Ethernet port (either directly or over a network) and the PDF printer is enabled in the firmware. Press **PRINT TABLE**. The Analyzer prints the table.
6. To export the *Stage 1 Conductivity* table, press **EXPORT TABLE**. The *Export* screen appears.

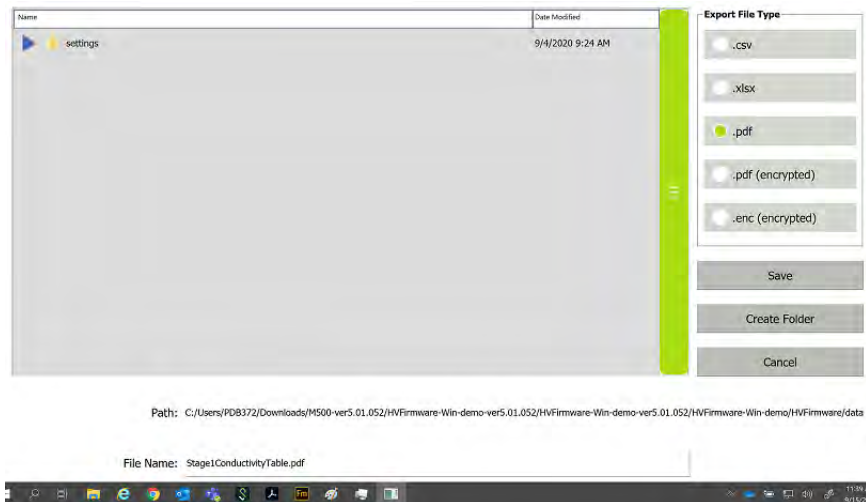

7. Leave the default settings, or revise as needed, and press **SAVE**. The Analyzer saves the table to the defined location and a confirmation message appears. For more information, see [“To export from an Analyzer screen” on page 124](#).



NOTE: A Stage 1 Conductivity table is only available for USP, EP, IP, and CP pharmacopoeias.



NOTE: The USP and EP conductivity acceptance criteria can be referenced in USP <645> and EP 2.2.38 Stage 1 conductivity requirements.

The JP conductivity acceptance criteria can be referenced in JP16 G8 "Quality Control of Water for Pharmaceutical Use" Stage 1 conductivity requirements.

Working with Pharmacopoeia Monographs

This section contains pass/fail reporting information and pharmacopoeia settings.

PASS/FAIL REPORTING

The TOC Analyzer will report a Pharmacopoeia “Pass” result, if all of the selected pharmacopoeia tests pass identified criteria and limits. The TOC Analyzer will report a Pharmacopoeia “Failure” result, if any of the selected tests fail. Conductivity and TOC tests can be independently tested with the alarms, an alarm can be set for each of TOC Limit, Cond Limit, or Limits. Limits will trigger if any of the TOC or conductivity tests fail. TOC Limit only if any of the TOC tests fail, and Cond Limit only if any of the conductivity tests fail.

PHARMACOPOEIA OPTIONS

Select any combination (or none) of the following Pharmacopoeia options:

- **USP WFI/PW:** The Analyzer meets the test requirements for the United States Pharmacopoeia (USP) monographs; USP<643> Total Organic Carbon and USP<645> Conductivity. The water passes the USP<643> TOC test if its measured TOC (ru) is not more than the Limit Response, (rs – rw). The water sample passes the Stage 1 conductivity test if the measured conductivity is not greater than the table value (at the first temperature in the chart that is not greater than the measured water temperature).
- **EP WFI/HPW:** The Analyzer meets the test requirements of the following European Pharmacopoeia (EP) monographs; EP (2.2.44) Total Organic Carbon in Water for Pharmaceutical Use and the Conductivity Requirements of the EP monographs “Water for Injections” (WFI) and “Water, Highly Purified” (HPW). The TOC test passes if the measured TOC of the pharmaceutical water sample is not less than the lower of the Limit Response or 500 ppbC (per the requirements of the EP WFI and HPW monographs). The Stage 1 conductivity test passes if the measured non-temperature compensated conductivity value is not greater than the conductivity value in the table for WFI at the next lower temperature (in the table), than the measured temperature of the water (Stage 1 test in the WFI or HPW monographs).
- **CP WFI:** The Analyzer meets the test requirements of the following Chinese Pharmacopoeia (CP) monographs; CP TOC Measurement in Pharmaceutical Water- Appendix VIII R for Water for Injection and CP Conductivity- Appendix VIII S for Water for Injection. The TOC test passes if the sample of WFI has a measured TOC value not greater than (rs – rw) or 0.50 g/L. The conductivity test passes Step 1 if the measured non-temperature compensated conductivity is not greater than the table conductivity value at the next lower temperature value in the table that is not greater than the measured temperature.
- **IP WFI:** The Analyzer meets the test requirements of the India Pharmacopoeia (IP) monographs for Water for Injection: IP 2.4.30 Total Organic Carbon in Water and IP 2.4.9 Conductivity for Water for Injections in Bulk. The TOC test is passed if the measured TOC of the sample (rt) is not greater than (rs – rw) or not more than 0.5 mg/L. The Stage 1 conductivity test is passed if the non-temperature corrected conductivity is not greater than the table value for WFI at the next lowest temperature value in the table that is not greater than the measured water temperature.
- **JP TOC:** The Analyzer meets the test requirements of the Japanese Pharmacopoeia (JP) monographs; JP<2.59> Total Organic Carbon for Water for Injection and Purified Water. The test passes if the measured Water for Injection or Purified Water sample TOC value is not greater than 0.50 mg/L.
- **EP PW:** The Analyzer meets the testing requirements of the following European Pharmacopoeia (EP) monograph for Purified Water (PW); EP<2.2.44 Total Organic Carbon in Water for Pharmaceutical Use and the Conductivity Requirements of the EP monographs “Water, Purified”. The TOC test passes if the measured TOC of the



pharmaceutical water sample is not less than the lower of the Limit Response or 500 ppbC (per the requirements of the EP PW monograph). The conductivity test passes if the measured conductivity (not the temperature compensated conductivity) is not greater than the value specified in the EP Acceptance Criteria at the measured temperature of the water. For temperatures not listed in the table, the maximal permitted conductivity is calculated by interpolation between the next lower and next higher temperature data points in the table.

- **CP PW:** The Analyzer meets the testing requirements for the following Chinese Pharmacopeia (CP) monographs; CP TOC Measurement in Pharmaceutical Water- Appendix VIII R for Water for Injection and CP Conductivity- Appendix VIII S for Water for Injection. The TOC test passes if the sample of WFI has a measured TOC value not greater than $(rs - rw)$ or 0.50 g/L. The conductivity test passes if the measured conductivity (not the temperature compensated conductivity) is not greater than the value in the CP Conductivity- Appendix VIII S (for purified water) monograph at the measured temperature of the water. For temperatures not listed in the table, the maximal permitted conductivity is calculated by linear interpolation between the next lower and next higher temperature data points in the table.
- **IP PW:** The Analyzer meets the testing requirements of the India Pharmacopeia (IP) monographs for Water for Injection: IP<2.4.30> Total Organic Carbon in Water and IP 2.4.9 and Conductivity IP<2.4.9> for Purified Water. The TOC test is passed if the measured TOC of the sample (rt) is not greater than $(rs - rw)$ or not more than 0.5 mg/L. The conductivity test passes Step 1, if the measured non-temperature compensated conductivity is not greater than the conductivity value in the table for Purified Water at the next lower temperature value in the table, that is not greater than the measured temperature.
- **JP COND:** The Analyzer meets the testing requirements of the Japanese Pharmacopeia (JP) Conductivity <2.51>. The test passes if the temperature corrected conductivity is not more than that referenced in the JP Acceptance Criteria.

Configuring Export Preferences

Use the *Configuring Export Preferences* panel to create default settings for use in exporting data. Also, use this panel to enable and define parameters for a daily export of results data from online analysis.

To configure export preferences

1. Navigate to the *Export Preferences* panel (*Settings*  screen > *System Setup* tab).

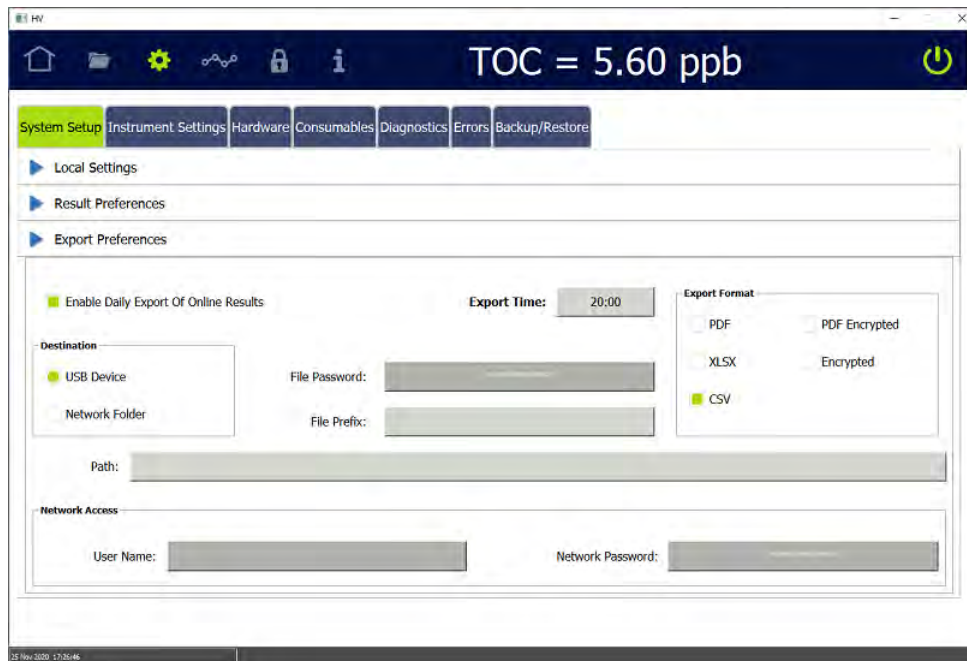

2. To enable a daily export of results data from online analysis:
 - Select the *Enable Daily Export Of Online Results* option.
 - Press inside the *Export Time* field and use the numeric keypad to enter a time (24-hour format) for the daily export.
 - Continue with the remaining steps in this procedure to create default settings for use in exporting data. In addition to displaying the default settings on the dialog boxes for exporting data, the Analyzer will use them for the daily export of results data.
3. To create default settings for use in exporting data, select one of the following options in the *Destination* area:
 - *USB Device*
 - *Network Folder*
4. For **USB Device**:
 - (Optional) To specify a default folder on the USB memory device, press inside the *Path* field and use the alphanumeric keypad to add the folder to the path. For example: ***/mnt/usb/daily_export***
 - If a daily export of results data from online analysis is enabled, ensure that a USB memory device is inserted into the Analyzer's USB port before the scheduled export.
5. For **Network Folder**:
 - Press inside the *Path* field and use the alphanumeric keypad to enter the network path. For example: ***/mnt/net/server-2/online_data***



- Press inside the *User Name* and *Network Password* fields and use the alphanumeric keypad to enter the required network security information.
6. (Optional) Press inside the *File Prefix* field and use the alphanumeric keypad to enter a user-assigned prefix for all exported files.
 7. In the *Export Format* area, select one or more of the following file formats for the export:
 - PDF
 - XLSX
 - CSV
 - PDF Encrypted

When this file format is selected, the *File Password* field becomes active. Press inside the field and use the alphanumeric keypad to enter the password required to open the exported PDF file.

- Encrypted

SETTINGS SCREEN — INSTRUMENT SETTINGS TAB

Viewing System Constants

System constants (settings) are stored in the Analyzer's memory and can be viewed on the *System Constants* panel. The system constants include: IC and TC cell constants, thermistor constants, calibration constants, and sample conductivity constants.

To view system constants

1. Navigate to the *System Constants* panel (*Settings*  screen > *Instrument Settings* tab).
2. View the following types of system constants, as needed:
 - IC and TC Cell Constants
 - Thermistor Constants
 - TOC Calibration Constants
 - Sample Calibration Constants

To review the model and serial number

When working with Technical Support or your local service provider, you will be asked to provide the serial number of the Analyzer. It is located on the *System Constants* panel (*Settings*  screen > *Instrument Settings* tab).

Saving System Constants

Backing up the Analyzer's database saves system constants (calibration and user-configurable settings) along with history data. If there is a need to return to previous settings, the system constants can be restored from any backup file. For more information, see [“Backing Up the Database” on page 175](#) and [“Restoring System Constants” on page 184](#).

Printing and Exporting of System Constants

System constants can be printed to a PDF printer, and the printed output can be saved as a record of the settings. System constants also can be exported to a USB memory device or network (according to the settings on the *Export Preferences* panel). For more information, see [“Configuring Export Preferences” on page 145](#).

To print and export system constants

1. On the *Settings*  screen, select the *Instrument Settings* tab.

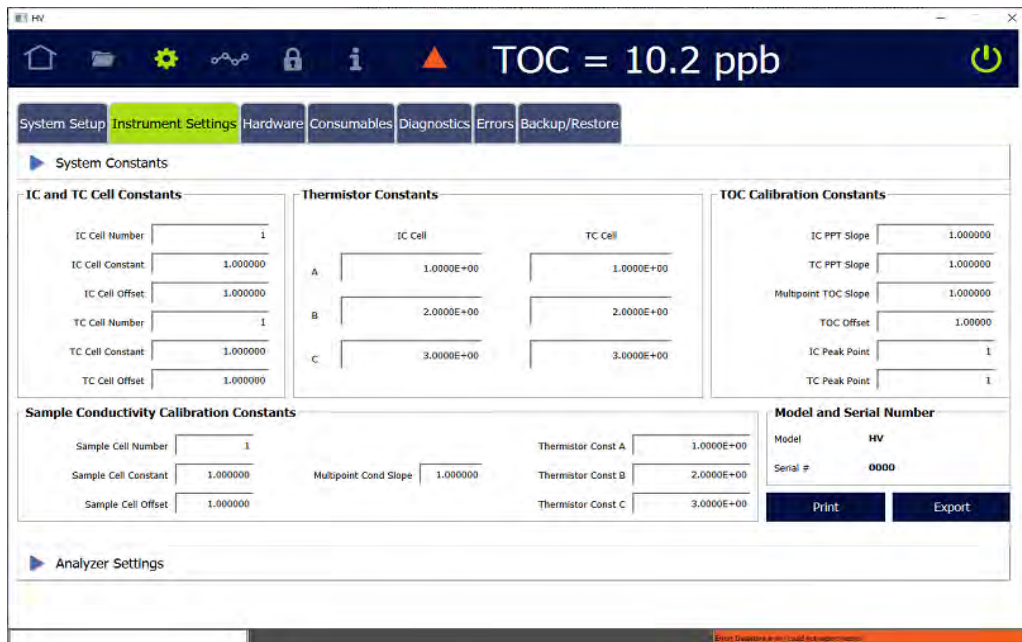

The screenshot shows the 'Instrument Settings' tab in the 'Settings' application. The top status bar displays 'TOC = 10.2 ppb'. The 'System Constants' section is expanded, showing several configuration panels:

- IC and TC Cell Constants:** IC Cell Number (1), IC Cell Constant (1.000000), IC Cell Offset (1.000000), TC Cell Number (1), TC Cell Constant (1.000000), TC Cell Offset (1.000000).
- Thermistor Constants:** IC Cell (A: 1.0000E+00, B: 2.0000E+00, C: 3.0000E+00), TC Cell (A: 1.0000E+00, B: 2.0000E+00, C: 3.0000E+00).
- TOC Calibration Constants:** IC PPT Slope (1.000000), TC PPT Slope (1.000000), Multipoint TOC Slope (1.000000), TOC Offset (1.000000), IC Peak Point (1), TC Peak Point (1).
- Sample Conductivity Calibration Constants:** Sample Cell Number (1), Sample Cell Constant (1.000000), Sample Cell Offset (1.000000), Multipoint Cond Slope (1.000000).
- Thermistor Const A, B, C:** 1.0000E+00, 2.0000E+00, 3.0000E+00.
- Model and Serial Number:** Model (HV), Serial # (0000).

Buttons for 'Print' and 'Export' are located at the bottom right of the configuration area.

2. (Optional) To print the system constants:
 - Ensure a PDF printer is connected to the Ethernet port (either directly or over a network) and the PDF printer is enabled in the firmware. (For information, see [“Enabling a PDF Printer” on page 170](#).)
 - On the *System Constants* panel press **PRINT**. The Analyzer prints a copy of the system constants.



- Save the printout. Technical Support or your local service provider might need to reference the system settings for Calibration constants and other key parameters.
3. To export the system constants, press **EXPORT**. The *Export* screen appears.

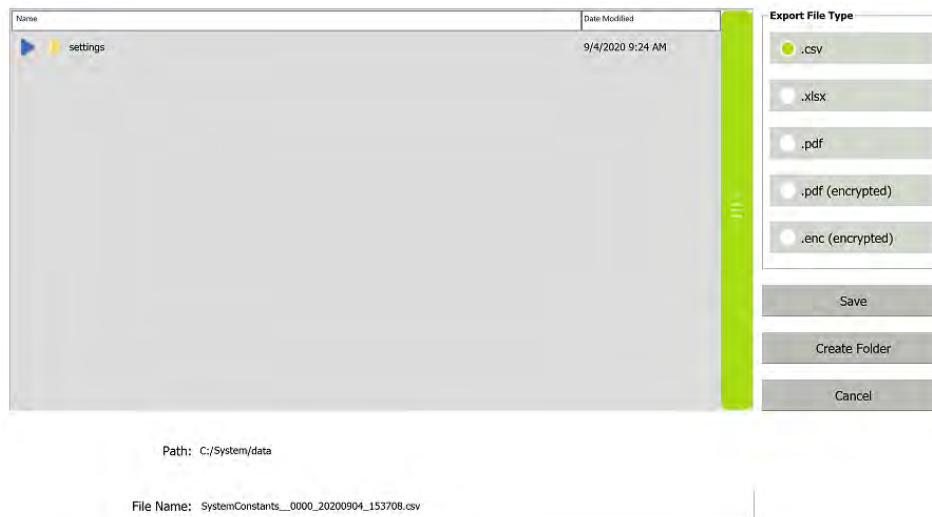

4. Leave the default settings, or revise as needed (for more information, see [“To export from an Analyzer screen” on page 124](#)), and press **SAVE**. The Analyzer exports the system constants to the defined location and a confirmation appears.
5. Press **OK** to confirm and close the message.
6. If a USB device was used, remove it for safe keeping.
7. Save the exported Settings file. Technical Support (or your local service provider) might need to reference the system settings for Calibration constants and other key parameters.

SETTINGS SCREEN — ANALYZER SETTINGS PANEL

The *Analyzer Settings* panel includes a scrolling table of each Analyzer setting and its value. The panel can also be used to export, print, and import settings.

Also included are the configurable User TOC Offset and Temperature Compensation fields. This is also the panel for activating Analyzer options, such as Sample Conductivity, Performance Qualification Protocols, DataGuard, and or the 3 Minute Analysis.

Reviewing Analyzer Settings

To review Analyzer settings

1. Navigate to the *Analyzer Settings* panel (*Settings*  screen > *Instrument Settings* tab). The Analyzer settings appear in the table to the left.

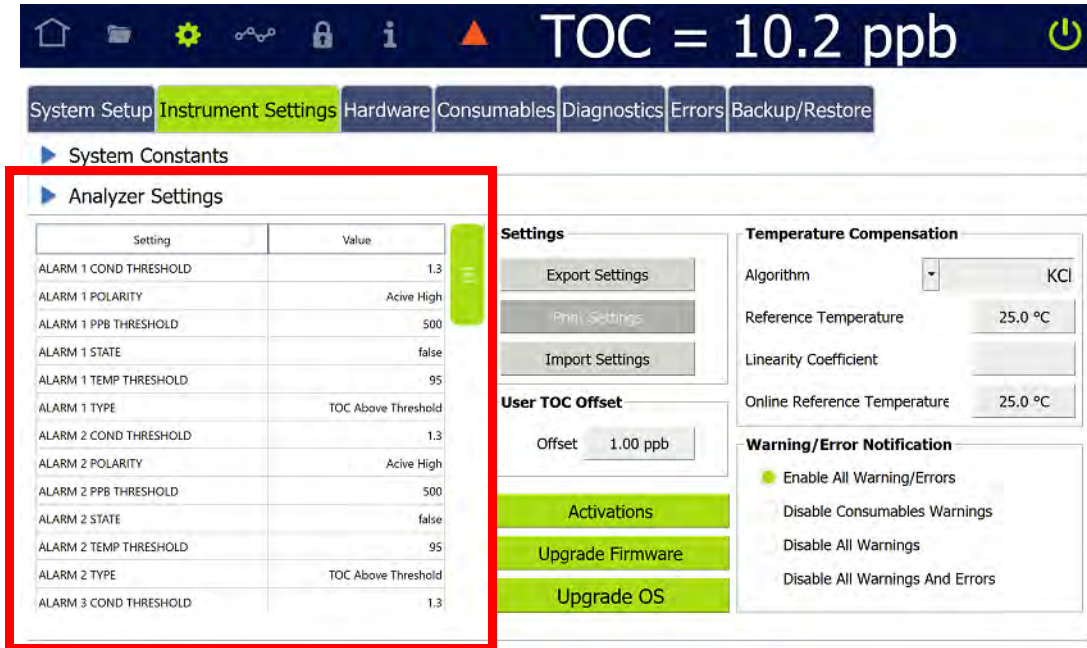

Setting	Value
ALARM 1 COND THRESHOLD	1.3
ALARM 1 POLARITY	Active High
ALARM 1 PPB THRESHOLD	500
ALARM 1 STATE	false
ALARM 1 TEMP THRESHOLD	95
ALARM 1 TYPE	TOC Above Threshold
ALARM 2 COND THRESHOLD	1.3
ALARM 2 POLARITY	Active High
ALARM 2 PPB THRESHOLD	500
ALARM 2 STATE	false
ALARM 2 TEMP THRESHOLD	95
ALARM 2 TYPE	TOC Above Threshold
ALARM 3 COND THRESHOLD	1.3

2. Use the scrollbar to view the various setting values in the table.

Saving Analyzer Settings

Print or export system Analyzer settings to a USB memory device or network to allow referencing and/or restoring them at a later time. This feature provides a back-up mechanism in the event for a need to return to previous settings or to create a file for transferring to one or more other Analyzers to enable setting up multiple Analyzers with identical settings. The Analyzer has an *Import Settings* feature to support importing such a file.

To print and export Analyzer settings

1. Navigate to the *Analyzer Settings* panel (*Settings*  screen > *Instrument Settings* tab).

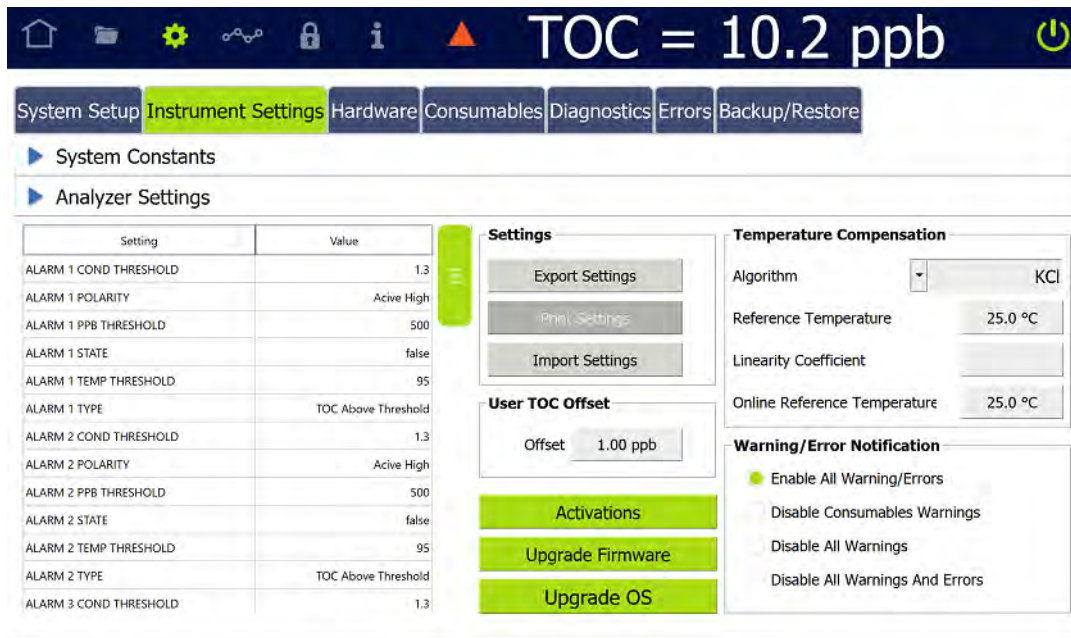

2. (Optional) To print the Analyzer settings, ensure a PDF printer is connected to the Ethernet port (either directly or over a network) and the PDF printer is enabled in the firmware.
3. On the *Analyzer Settings* panel press **PRINT**. The Analyzer prints a copy of the settings. Save the printout for any future Technical Support or your local service provider needs to reference the factory settings.
4. To export the system settings, press **EXPORT**. The *Export* screen appears.

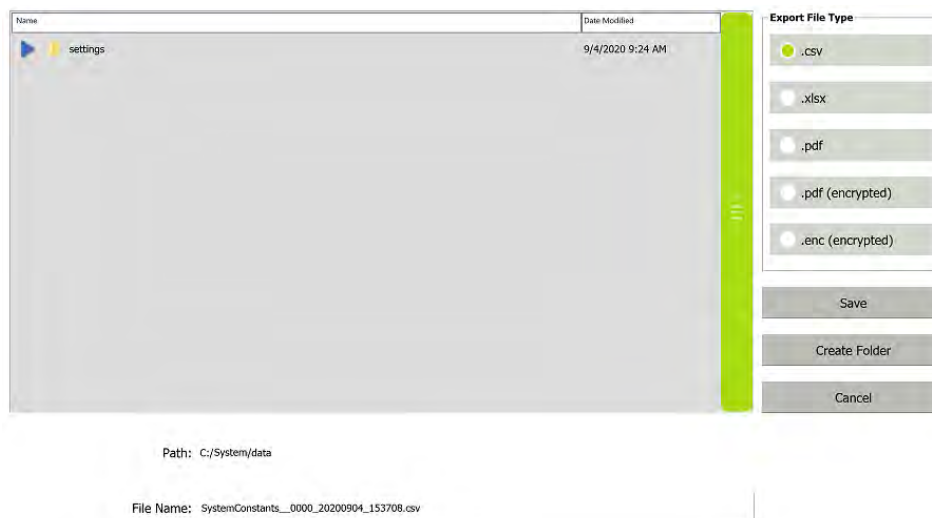

5. Leave the default settings, or revise as needed, and press **SAVE**. The Analyzer exports the settings to the defined location and a confirmation appears. For more information, refer to [“To export from an Analyzer screen” on page 124](#).

6. Press **OK** to confirm and close the message.

Importing Analyzer Settings

To import Analyzer settings

1. Navigate to the Analyzer Settings panel (*Settings*  screen > *Instrument Settings* tab).
2. Press **IMPORT SETTINGS**. The *Name* (import) dialog box appears.

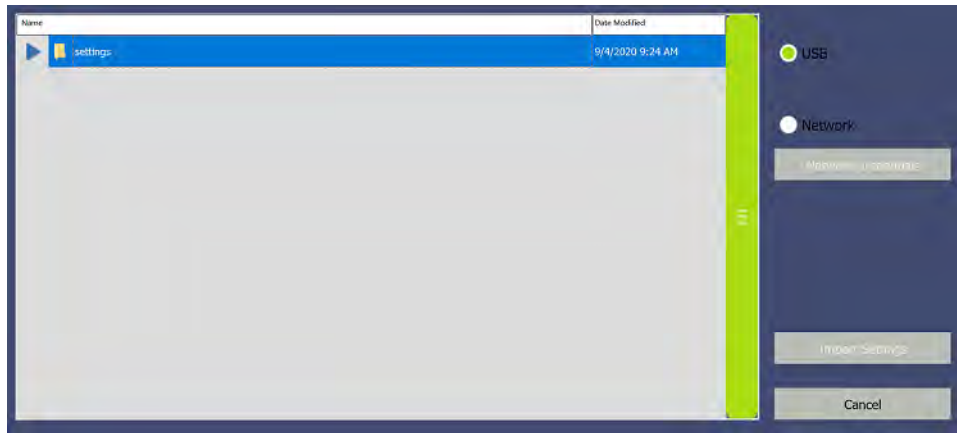

3. Select a source file location option: **USB** or **Network**. If **Network** is selected, press **NETWORK CREDENTIALS**. The network path dialog box appears. Otherwise, if **USB** is selected, go to step [8](#).

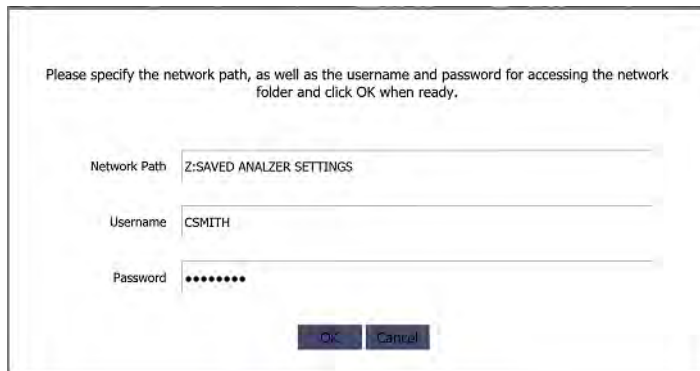

4. Complete the following and press **OK**.
 - Network Path
 - Username
 - Password
5. In the *Name* area, select the file to import and press **Import Settings**. The Analyzer imports the new settings and a confirmation message appears.
6. Press **OK** to confirm and close the message.

Setting a User TOC Offset

At extremely low TOC concentrations, very small changes in water system conditions may make it difficult to use the TOC Autozero procedure for the purposes of achieving instrument-to-instrument agreement consistent with the stated analyzer specifications. If the TOC Autozero procedure does not yield acceptable agreement between multiple instruments, use this manual *User TOC zero offset* adjustment to adjust the TOC reading to match a known accurate reference value.

To set a user TOC offset

1. Navigate to the *Analyzer Settings* panel (*Settings*  screen > *Instrument Settings* tab).
2. In the *User TOC Offset* area, press inside the *Offset* field and use the numeric keypad to enter a ppb value between **-5.00** and **5.00** and press **OK** to save.

Setting Conductivity Temperature Compensation

(For Analyzers with the Sample Conductivity option **only**.)

The Analyzer allows the change of the reference algorithm and temperature for conductivity System Protocols. The following temperature compensation algorithms are available.

- *NaCl* (sodium chloride)
- *KCl* (potassium chloride)
- *HCl* (hydrochloric acid)
- *Linear* (%/degree)

For information about selecting the appropriate compensation algorithm, refer to [Appendix F. "Temperature Compensation."](#)

To set the sample conductivity reference temperature

1. Navigate to the *Analyzer Settings* panel (*Settings*  screen > *Instrument Settings* tab).

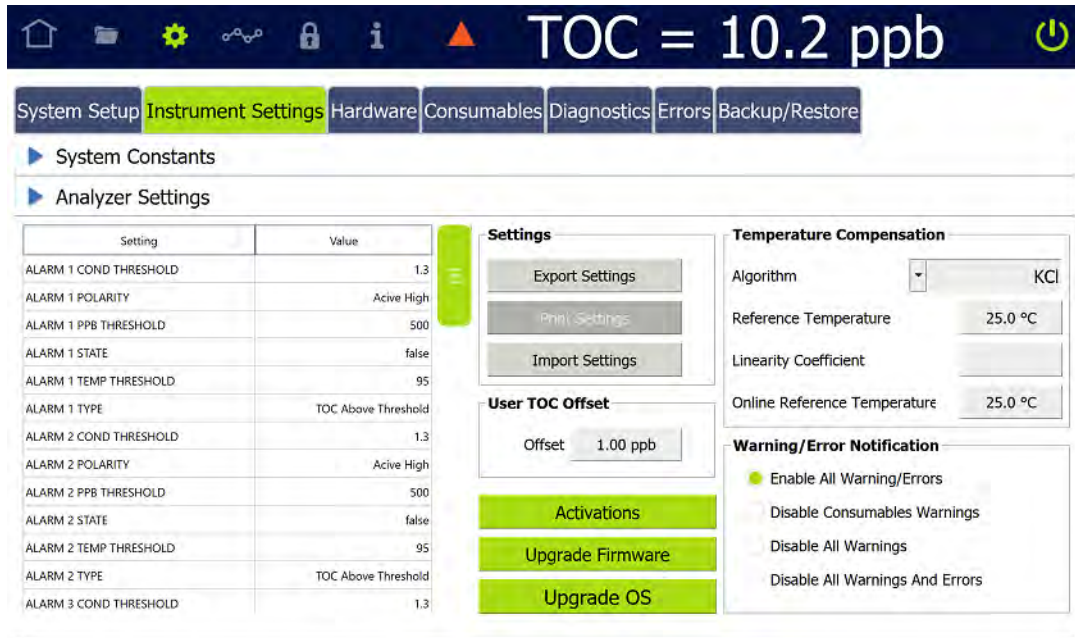

2. In the *Temperature Compensation* area, select one of the following from the *Algorithm* list:
 - NaCl
 - KCl
 - HCl
 - Linear
3. If *Linear* is selected for the reference type, leave the default value in the *Linear Coefficient* field or type in a new value. (The field is inactive for all other reference types.)
4. Press inside the *Online Reference Temperature* field and use the numeric keypad to enter a number between 5 and 95, with a maximum 1 decimal format (**XX.X**). The value automatically appears as °C.



NOTE: For most regions of the world, 25 °C is the reference temperature used for compensation. It is also the temperature at which conductivity standards are certified. Some regions will use other reference temperatures, such as 20 °C. The Analyzer allows the user to select the reference temperature to use in the compensating (correction-type) algorithms. For more information, refer to [Appendix F. "Temperature Compensation."](#)

Activating Options

Use this instruction to activate Analyzer options that were not activated in the factory, such as: Sample Conductivity, Performance Qualification (PQ) Protocols, DataGuard, and/or the 3 Minute Analysis. Activating each option requires an activation code to enter into the Analyzer's firmware. These codes are e-mailed directly to your company after purchasing the options.

To activate an Analyzer option

1. Locate the Activation Code previously e-mailed from SUEZ.
2. Navigate to the *Analyzer Settings* panel (*Settings*  screen > *Instrument Settings* tab).

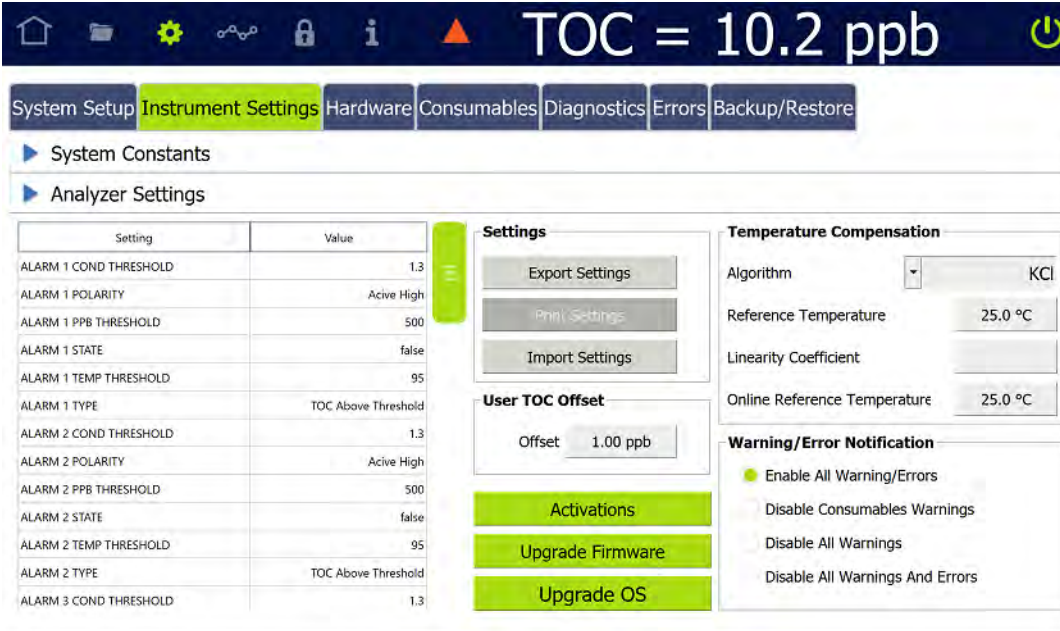

Setting	Value
ALARM 1 COND THRESHOLD	1.3
ALARM 1 POLARITY	Active High
ALARM 1 PPB THRESHOLD	500
ALARM 1 STATE	false
ALARM 1 TEMP THRESHOLD	95
ALARM 1 TYPE	TOC Above Threshold
ALARM 2 COND THRESHOLD	1.3
ALARM 2 POLARITY	Active High
ALARM 2 PPB THRESHOLD	500
ALARM 2 STATE	false
ALARM 2 TEMP THRESHOLD	95
ALARM 2 TYPE	TOC Above Threshold
ALARM 3 COND THRESHOLD	1.3

3. Press **ACTIVATIONS**. The *Enter Activation Code* dialog box appears.



Enter Activation Code

8G9A-4UG4-0QMN

Features To Be Activated

Sample Conductivity Enabled

Apply Close

4. Press inside the *Enter Activation Code* field and use the alphanumeric keypad to enter the activation code provided by SUEZ. The feature appears in the *Features To Be Activated* area.

Chapter 4 BASIC ANALYZER OPERATION

5. To install the feature shown, press **APPLY**. A confirmation message appears.
6. Press **YES** to continue. The Activations dialog box closes and the system adds the feature shown to the Analyzer.

Upgrading Firmware

Use these instructions to install firmware updates:

- [“To upgrade firmware using a USB memory device” on page 156](#)
- [“To upgrade firmware through a network connection” on page 157](#)

To upgrade firmware using a USB memory device

1. Power cycle the Analyzer and before re-starting, insert the USB memory device (with the firmware update) into the USB port.
2. Navigate to the *Analyzer Settings* panel (*Settings*  screen > *Instrument Settings* tab).

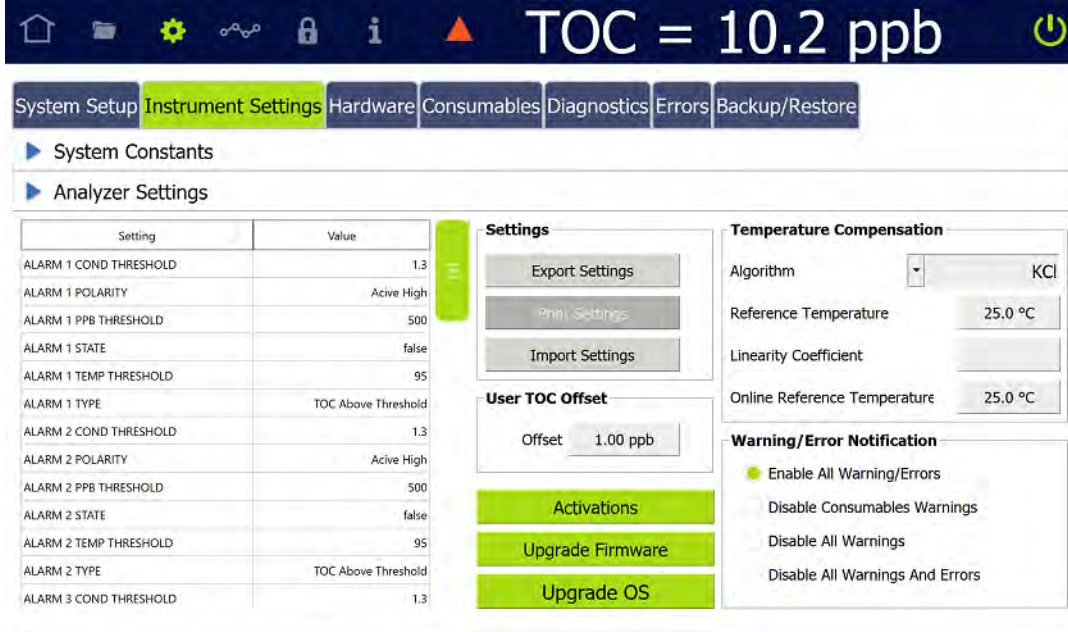

The screenshot shows the Analyzer Settings interface. At the top, the TOC is 10.2 ppb. The Instrument Settings tab is selected. The interface includes a table of settings, a Settings panel with buttons for Export, Print, and Import, a User TOC Offset section, and a Temperature Compensation section with Algorithm, Reference Temperature, Linearity Coefficient, and Online Reference Temperature. The Warning/Error Notification section has radio buttons for Enable All Warning/Errors, Disable Consumables Warnings, Disable All Warnings, and Disable All Warnings And Errors. The Upgrade Firmware button is highlighted in green.

Setting	Value
ALARM 1 COND THRESHOLD	1.3
ALARM 1 POLARITY	Active High
ALARM 1 PPB THRESHOLD	500
ALARM 1 STATE	false
ALARM 1 TEMP THRESHOLD	95
ALARM 1 TYPE	TOC Above Threshold
ALARM 2 COND THRESHOLD	1.3
ALARM 2 POLARITY	Active High
ALARM 2 PPB THRESHOLD	500
ALARM 2 STATE	false
ALARM 2 TEMP THRESHOLD	95
ALARM 2 TYPE	TOC Above Threshold
ALARM 3 COND THRESHOLD	1.3

3. On the *Analyzer Settings* panel, press **UPGRADE FIRMWARE**. The *Name* (Firmware Upgrade) screen appears.

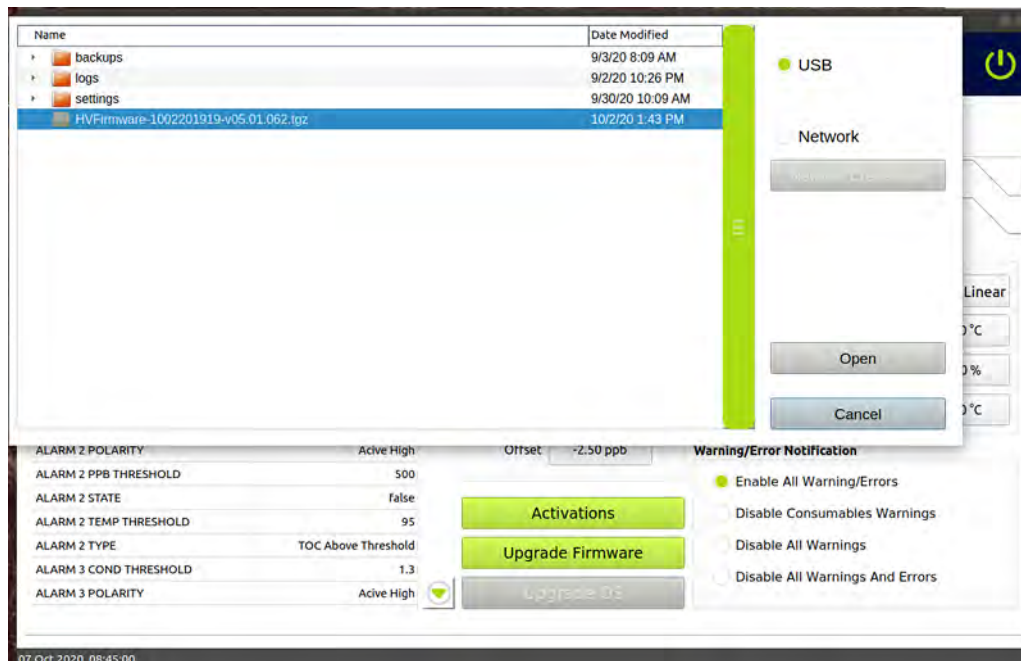

NOTE: All files contained on the USB memory device will appear on the this screen. Select **only** the firmware upgrade file.

4. Select the upgrade file and press the **OPEN** button. The Analyzer starts the upgrade. After the progress indicator reaches 100% complete, a **RESTART** button appears.
5. Press **RESTART** to complete the upgrade process. The *Home*  screen appears.
6. Remove the USB memory device from the Analyzer USB port.

To upgrade firmware through a network connection

1. Navigate to the *Analyzer Settings* panel (*Settings*  screen > *Instrument Settings* tab).
2. On the *Analyzer Settings* panel, press **UPGRADE FIRMWARE**. The dialog box for upgrading the firmware appears.

Chapter 4 BASIC ANALYZER OPERATION

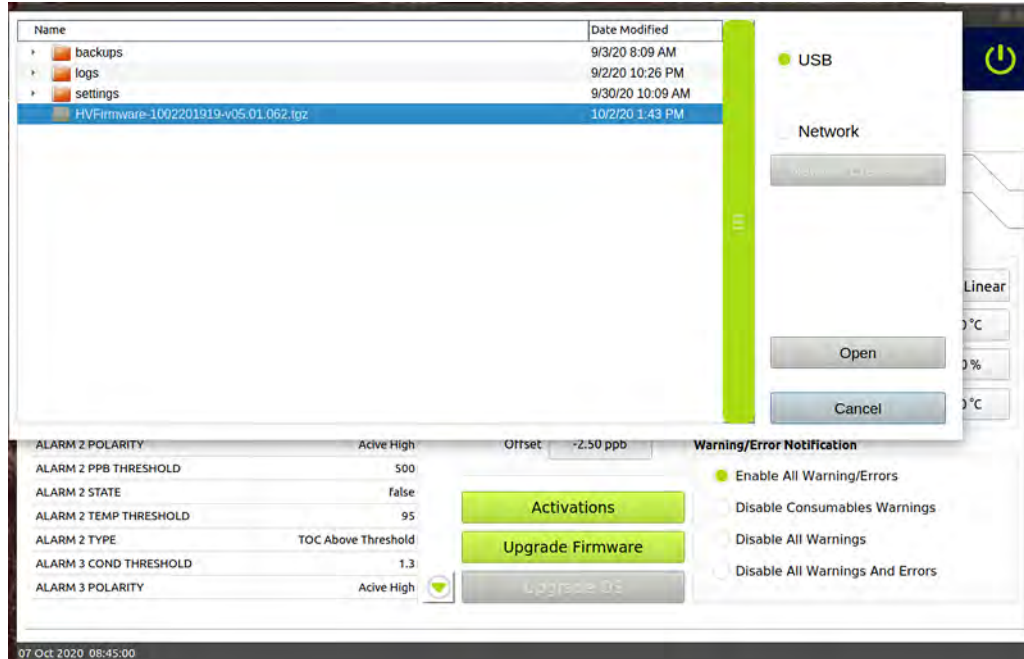

3. Select the *Network* option and press the **NETWORK CREDENTIALS** button. A dialog box for accessing the network folder appears.

Please specify the network path, as well as the username and password for accessing the network folder and click OK when ready.

Network Path

Username

Password

4. Enter the network path, user name, and password to access the network folder and press **OK**. A screen that lists files within the network folder appears.
5. Select the upgrade file and press the **OPEN** button. The Analyzer starts the upgrade. After the progress indicator reaches 100% complete, a **RESTART** button appears.
6. Press **RESTART** to complete the upgrade process. The *Home*  screen appears.

SETTINGS SCREEN — HARDWARE TAB

The *Hardware* tab includes a scrollable menu of various Analyzer functionality for Analyzer setup and other hardware features. Each menu selection either includes wizard screens to guide the user with step-by-step instructions and photos or a settings screen. For each settings screen, accompanying instructions are included in this section.

For each menu item, select the Hardware feature in the scrolling table and press **RUN**. The corresponding wizard or settings screen appears.

The menu includes the following:

- Accelerated Rinse (wizard) — Follow the screen instructions to perform an accelerated rinse of the Analyzer.
- Alarms Setup — Use the *Alarms Setup* screen to set alarm parameters. Refer to [“Configuring Alarm Outputs” on page 160](#) for step-by-step instructions.
- Analog Output Calibration (wizard) — Follow the screen instructions to calibrate each analog output.
- Analog Outputs Setup — Use the *Analog Out Setup* screen to set alarm parameters. Refer to [“Configuring Alarm Outputs” on page 160](#) for step-by-step instructions.
- Backflush (wizard) — Follow the screen instructions to backflush of the sample side of the DI side fluidics. This can clear any clogs in tubing when a lack of flow is indicated by Analyzer.
- Binary Inputs Setup — Use the *Binary Inputs Setup* screen to set alarm parameters. Refer to [“Configuring Binary Input \(Start/Stop\)” on page 163](#) for step-by-step instructions.
- Drain Instrument (wizard) — Follow the screen instructions to drain the sample side and/or DI loop.
- Ethernet Setup — Use the *Ethernet Setup* screen to enable an Ethernet connection. Refer to [“Configuring an Ethernet Connection” on page 165](#) for step-by-step instructions.
- Flow Sensor Setup — Use the *Flow Sensor Setup* screen to enable the flow sensor and the *No Flow* Alarm. Refer to [“Configuring the Flow Sensor” on page 166](#) for step-by-step instructions.
- Flush Super iOS (wizard) — Follow the screen instructions to drain the sample side and/or DI loop.
- Instrument Startup Wizard — (Follow these wizard screens **only** when first installing the Analyzer, as described in [“Step 7: Install the DI Water System” on page 77](#) in [Chapter 3. “Installation.”](#)) For instructions on filling the DI Water

Reservoir, priming the DI Loop, and rinsing down the measurement module **after the initial installation process**, refer to [Chapter 8, "Maintenance."](#)

- Level Sensor Setup — Use the *Level Setup* screen to enable the DI Reservoir Level Sensor. Refer to ["Configuring the Flow Sensor" on page 166](#) for step-by-step instructions.
- UV Lamp Setup — Use the *UV Lamp Setup* screen to temporarily turn off the UV lamp. See ["To enable the UV Lamp" on page 169](#) for step-by-step instructions.
- Printer Setup — Use the *Printer Setup* screen to enable a PDF printer connected to the Analyzer directly or over an Ethernet network. Refer to ["Enabling a PDF Printer" on page 170](#) for step-by-step instructions.
- WiFi Setup — Use the *WiFi Setup* screen to enable a WiFi connection. Refer to ["Configuring a WiFi Connection \(Optional\)" on page 172](#) for step-by-step instructions.

Configuring Alarm Outputs

The Sievers M500 TOC Analyzer has four customizable alarm outputs, configurable to trigger if the measured TOC, TC, or IC exceeds a set value — or if a warning or error occurs. Use this instruction for configuring the alarms wired earlier in ["Step 4: Install I/O Control Wiring \(Optional\)" on page 64](#). On configurations without conductivity measurement, some options are not available.

To set up alarm output



NOTE: You may need to consult with your remote operations center to determine some of the values.

1. On the *Settings*  screen, select the *Hardware* tab.

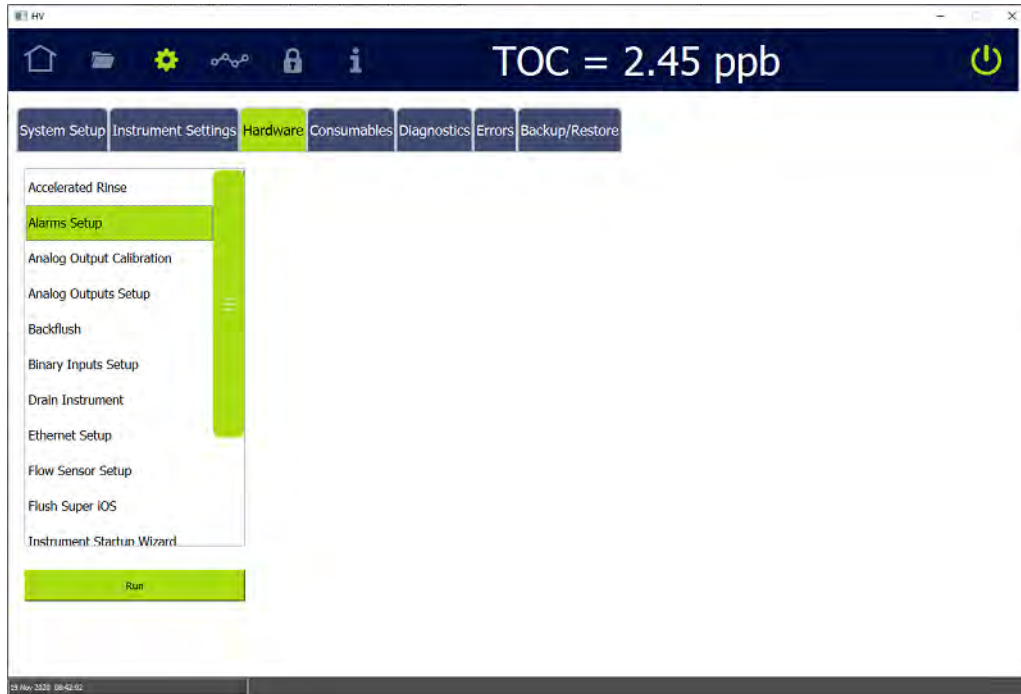

2. On the scrolling menu, select *Alarms Setup* and press **RUN**. The *Alarms Setup* screen appears.



3. In the *Select Alarm* area, select one of the following options to configure (*Alarm 1*, *Alarm 2*, *Alarm 3*, or *Alarm 4*).
4. Press the *Threshold* field and use the numeric keypad to set a value for the alarm threshold (1-3000 ppb) and press **OK**.
5. In the table area, select an assignment option for applying the alarm (such as *TOC>Threshold*, *Error or Warning*, or *Temperature > Threshold*).
6. Repeat steps 3 - 5 for each alarm to configure.
7. Press **SAVE**.

Configuring 4-20 mA Analog Outputs

To set up 4-20 mA analog outputs

If alarm outputs, 4-20 mA outputs, and/or binary inputs were installed, configure the connections with the appropriate values for those features now. The Sievers M500 TOC Analyzer has three 4-20 mA outputs. Select the output range for the 4-20 mA analog outputs by following these steps. Instructions for wiring the 4-20mA output can be found in Chapter 3: [Installation on page 61](#). On configurations without conductivity measurement, some options are not available.

1. On the *Settings*  screen, select the *Hardware* tab.

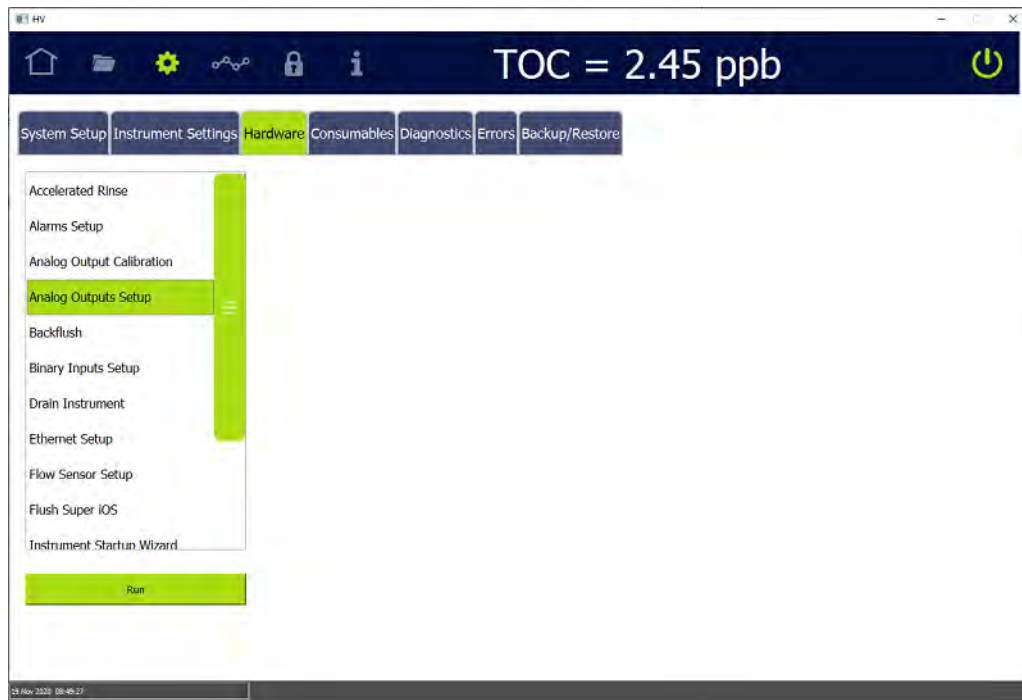

2. On the scrolling menu, select *Analog Outputs Setup* and press **RUN**. The *Analog Outputs Setup* screen appears.

Analog Outputs Setup

Analog Outputs - Standby, Error, Warning Values

Standby Error Warning

Analog Output 1	Analog Output 2	Analog Output 3
Value <input type="text" value="TOC"/>	Value <input type="text" value="TOC"/>	Value <input type="text" value="TOC"/>
Min Value <input type="text" value="0.00 ppb"/>	Min Value <input type="text" value="0.00 ppb"/>	Min Value <input type="text" value="0.00 ppb"/>
Max Value <input type="text" value="500 ppb"/>	Max Value <input type="text" value="500 ppb"/>	Max Value <input type="text" value="500 ppb"/>
System Protocols <input type="radio"/> Go To Standby	System Protocols <input type="radio"/> Go To Standby	System Protocols <input type="radio"/> Go To Standby
Output Values	Output Values	Output Values



3. In the *Analog Outputs - Standby, Error, Warning Values* area, select values for each of the following:
 - **Standby** — Select one of the following values to set when the Analyzer switches out of analysis mode into standby mode: *1 mA, 2.5 mA, 4 mA, 20 mA, 22 mA* or *Hold Last*.
 - **Error** — Select one of the following values to set when the Analyzer issues an error: *1 mA, 2.5 mA, 4 mA, 20 mA, 22 mA* or *Hold Last*.
 - **Warning** — Select one of the following values to set when the Analyzer issues a warning: *1 mA, 2.5 mA, 4 mA, 20 mA, 22 mA* or *Hold Last*.
4. In the area for the analog output to configure (1, 2, or 3), specify the calibration values:
 - **Value** — Select the analog output value (TOC, TC, or IC).
 - **Min Value** — Enter the lowest value (ppb) for output.
 - **Max Value** — Enter the highest value (ppb) for output.
 - **System Protocols** — Select one of the following for running system protocols: *Go To Standby* to output the Standby value entered in step 3 or *Output Values* to output actual values from protocol analyses.
5. Press **SAVE**.

Configuring Binary Input (Start/Stop)

To set the binary input

Enable the binary input connection for communicating remote start and stop commands to the Analyzer. The Analyzer's flow switch status overrides **Binary Input** settings. When the flow switch detects loss of sample flow to the Analyzer, analysis will not begin until sample flow resumes.

1. On the *Settings*  screen, select the *Hardware* tab.

Chapter 4 BASIC ANALYZER OPERATION

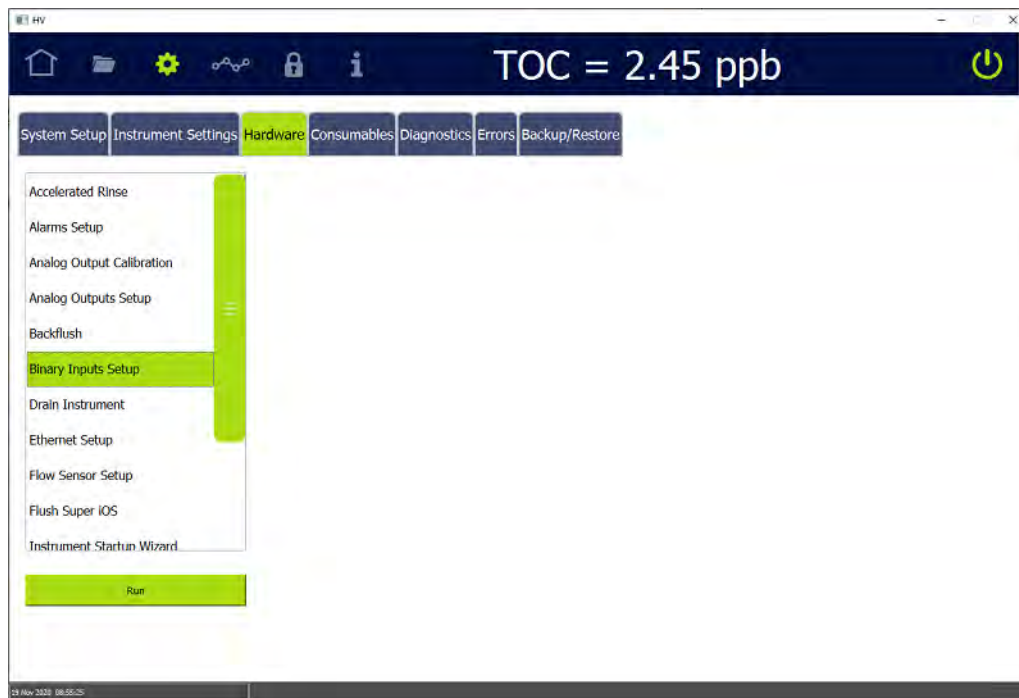

2. On the scrolling menu, select *Binary Inputs Setup* and press **RUN**. The *Binary Inputs Setup* screen appears.

The screenshot shows the 'Binary Inputs Setup' screen. It is divided into two columns for 'Binary Input 1' and 'Binary Input 2'.
For Binary Input 1:
- A text box contains 'Binary Input 1'.
- Below it, the text reads 'This input will remotely stop/start analysis'.
- There are two radio button options: 'Enable Binary Input 1' (which is selected) and 'Disable Binary Input 1'.
- Under 'Enable Binary Input 1', there are two radio button options: 'Run analysis when input is high' and 'Run analysis when input is low' (which is selected).
- At the bottom of the column, it says 'Binary Input 1 is high'.
For Binary Input 2:
- A text box contains 'Binary Input 2'.
- Below it, the text reads 'This input is disabled. Using IOS flow sensor.'.
- There are two radio button options: 'Enable Binary Input 2' and 'Disable Binary Input 2'.
- Under 'Enable Binary Input 2', there are two radio button options: 'Flow when input is high' and 'Flow when input is low' (which is selected).
- Below that, there is a radio button option 'Restart analysis when flow returns'.
- At the bottom of the column, it says 'Binary Input 2 is high'.
At the bottom of the screen, there are two buttons: a green 'Save' button and a grey 'Cancel' button.

3. In the area for the binary input to configure, select the *Enable Binary Input 1* (or *Enable the Binary Input 2*) option.
4. Select the *Run analysis when input is high* or the *Run analysis when input is low* option.
5. Repeat steps [3](#) through [4](#) for the other binary input connection.
6. Press **SAVE**.



Configuring an Ethernet Connection

To configure an Ethernet connection

Use this instruction to enable the Ethernet connection and set up a manual (fixed) IP address or an automatic (dynamic) IP address.

After configuring the Ethernet connection:

- To collect data, use a third-party data acquisition software or a SCADA system with Modbus TCP/IP to support the collection of real-time instrument data and status information. For more information, refer to [Appendix E: "Modbus with the Analyzer"](#) and ["Streaming Data" on page 433](#).
- To print to a PDF printer, configure the printer connection. For more information, refer to ["Enabling a PDF Printer" on page 170](#).

1. On the *Settings*  screen, press the *Hardware* tab.



2. On the scrolling menu, select *Ethernet Setup* and press **RUN**. The *Ethernet Setup* dialog box appears.

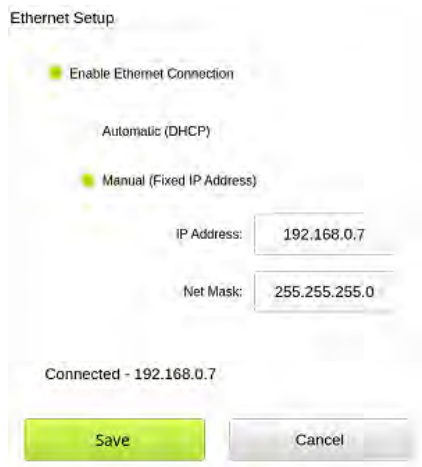

3. Select the *Enable Ethernet Connection* option.
4. Do one of the following:
 - Select the *Automatic* option for a dynamic IP address.
 - Select the *Manual* option for a fixed address and enter the IP Address and Net Mask numbers.
5. Press **Save**.

Configuring the Flow Sensor

When the water flow is interrupted during *Online* analysis, the Analyzer stops analysis after a pre-determined amount of time. A *No Flow* alarm can also be enabled to issue an error when the Analyzer detects no flow. The settings can also be configured to automatically restart analysis when the flow returns.

To enable the Flow Sensor

1. On the *Settings*  screen, press the *Hardware* tab.

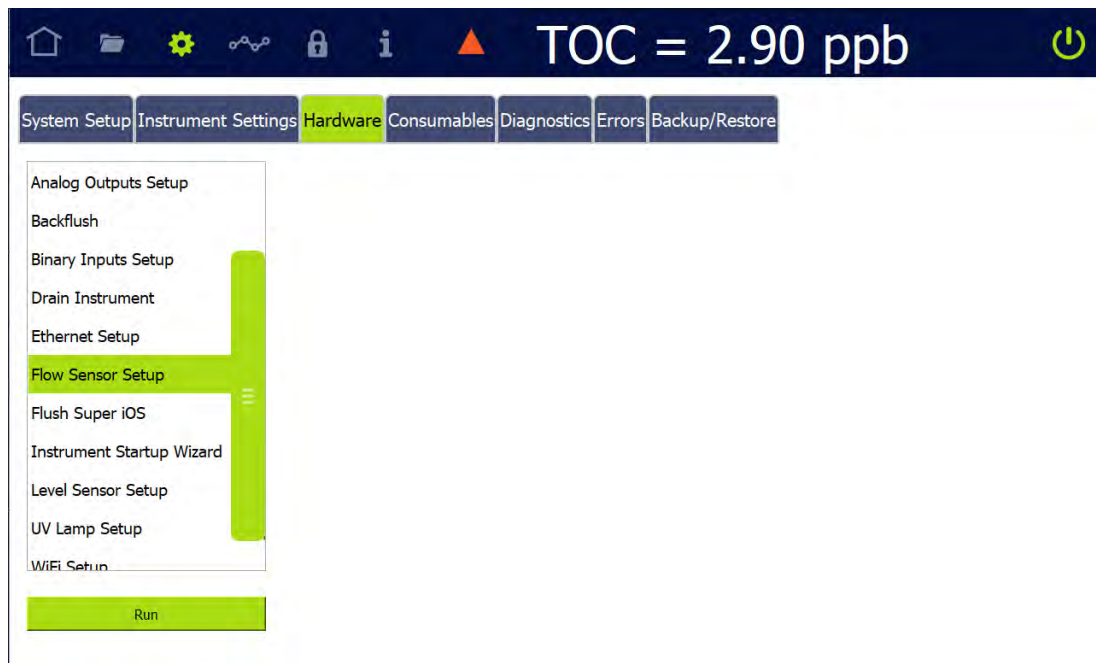

2. On the scrolling menu, select *Flow Sensor Setup* and press **RUN**. The *Flow Sensor Setup* dialog box appears.

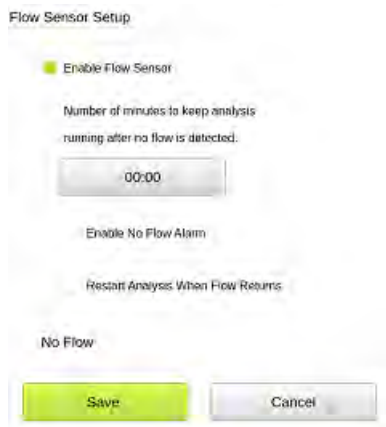

3. Select the *Enable Flow Sensor* option.
4. Press inside the minutes field and use the numeric keypad to enter the number of minutes (0-90) to keep the analysis running.
5. (Optional) Select the *Enable No Flow Alarm* option to instruct the Analyzer to record the warning when the flow is interrupted.
6. (Optional) Select the *Restart Analysis When Flow Returns* option.
7. Press **SAVE**.

Cautions

Operating the Analyzer in *Online* mode with no sample flow and with the Flow Sensor off can result in erroneous measurements.

Enabling the DI Reservoir Level Sensor

When enabled, the Level Sensor monitors the water level in the DI Reservoir and the Analyzer issues a warning message if the level of water falls below the *Add* line.

To enable the Level Sensor

1. On the *Settings*  screen, press the *Hardware* tab.

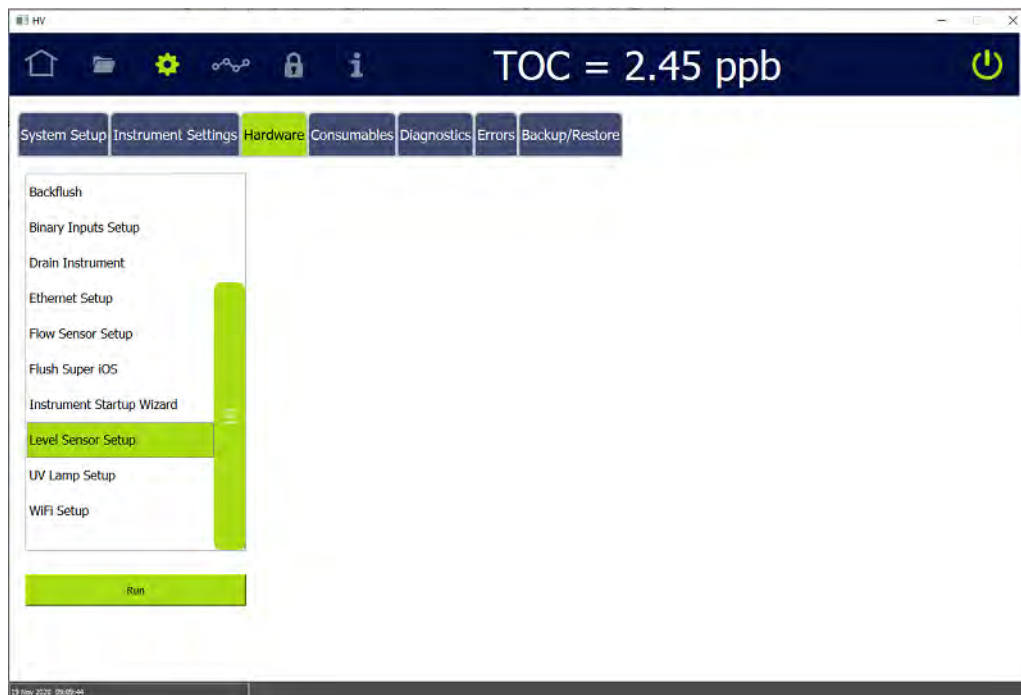

2. On the scrolling menu, select *Level Sensor Setup* and press **RUN**. The *Level Sensor Setup* dialog box appears.

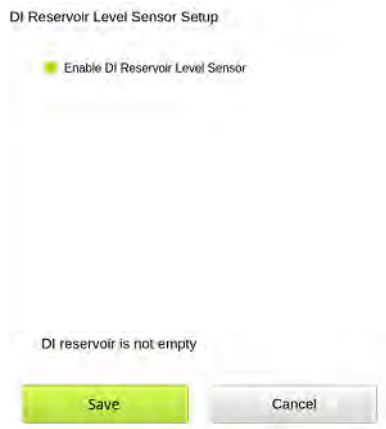

3. Select the *Enable DI Reservoir Level Sensor* option.
4. Press **SAVE**.

Enabling the UV Lamp

An option to disable the UV lamp is available for troubleshooting purposes, if needed.

To enable the UV Lamp

1. On the *Settings*  screen, press the *Hardware* tab.

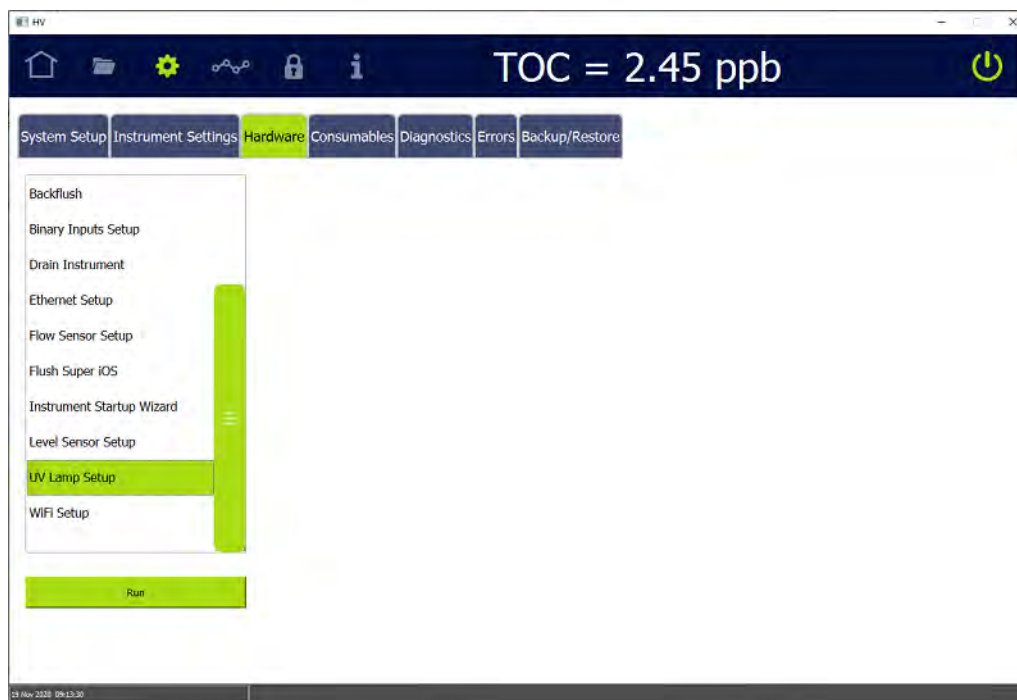

2. On the scrolling menu, select *UV Lamp Setup* and press **RUN**. The *UV Lamp Setup* dialog box appears.



3. Select the *Turn Off UV Lamp Temporarily During Analysis* option.
4. Press **SAVE**.
5. When troubleshooting is completed, return to this menu and deselect the option.

Enabling a PDF Printer

After a direct or network Ethernet connection to a PDF printer has been set up and configured (refer to [“Installing an Ethernet Connection \(Optional\)” on page 89](#) and [“Configuring an Ethernet Connection” on page 165](#)), the PDF printer must be enabled in the firmware.

To enable a PDF printer

1. Ensure the PDF printer is connected to the Analyzer directly or over an Ethernet network.
2. On the *Settings*  screen, press the *Hardware* tab.

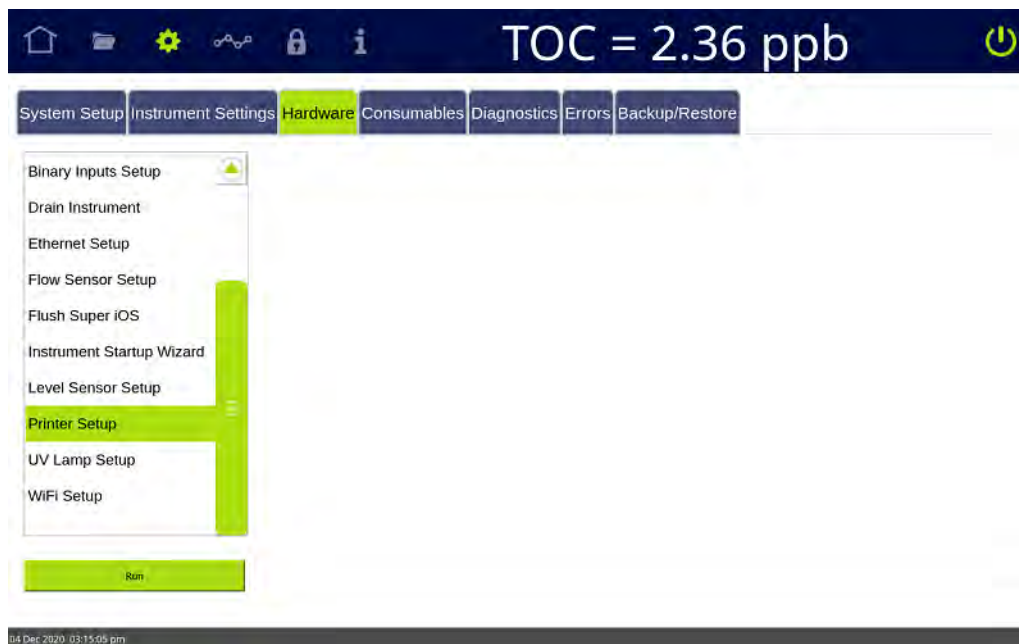

3. On the scrolling menu, select *Printer Setup* and press **RUN**. The *Printer Setup* dialog box appears. The Analyzer checks for all PDF printers that are available over the Ethernet connection and lists the printers in a dialog box.

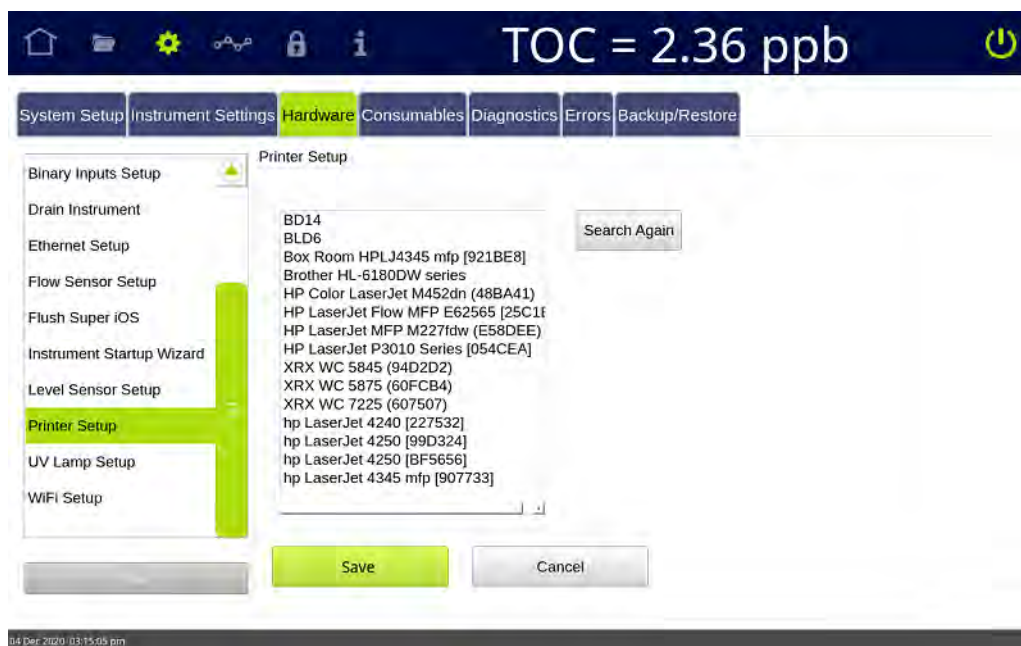

4. Select the printer to enable for use with the Analyzer.
5. Press **SAVE**.
6. To send a test page to the printer, navigate to the scrolling menu for *System Tests* (*Settings*  screen > *Diagnostics* tab).
7. Select *Printer* and press **RUN**. The Analyzer sends a test page to the printer.

Chapter 4 BASIC ANALYZER OPERATION

8. Check the printer to ensure that it printed the test page. Consult the printer manufacturer's instructions for additional help, as needed.

Configuring a WiFi Connection (Optional)

To configure a WiFi connection

Use this instruction to enable a wireless connection when the WiFi option has been purchased.



NOTE: This feature is only available in select countries.

1. On the *Settings*  screen, press the *Hardware* tab.

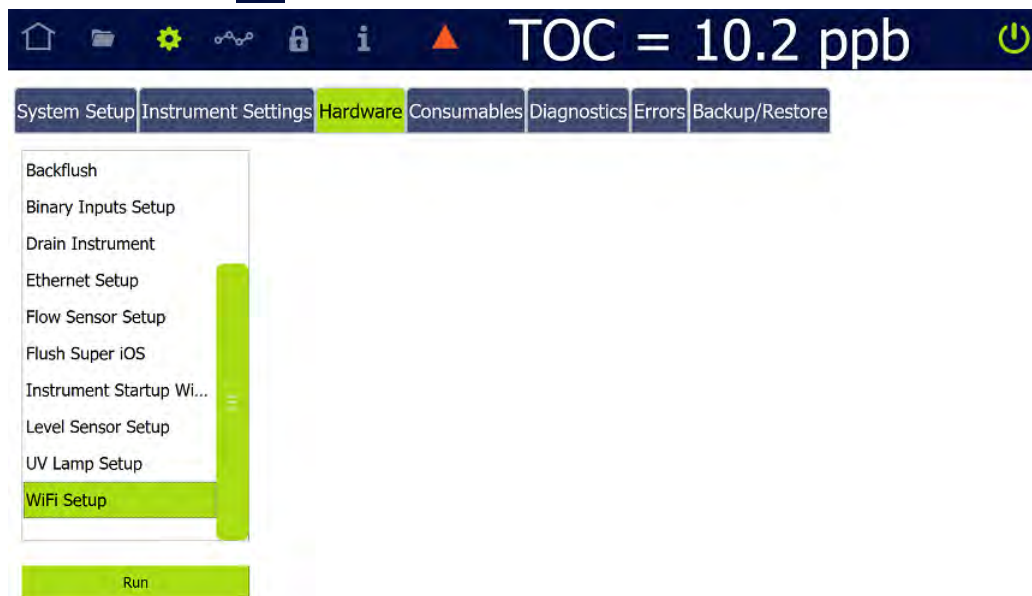

2. On the scrolling menu, select *WiFi Setup* and press **RUN**. The *WiFi Setup* dialog box appears.



WiFi Setup

Enable WiFi Connection

Automatic (DHCP) Access Point:

Manual (Fixed IP Address) Password:

IP Address:

Net Mask:

OS Version not supported

3. Select the *Enable WiFi Connection* option.
4. Do one of the following:
 - Select the *Automatic* option for a dynamic IP address.
 - Select the *Manual* option for a fixed address and enter the IP Address and Net Mask numbers.
5. Select the *Access Point* field. Select the access point.
6. If the WiFi network requires a password, select the *Password* field and enter the password.
7. Press **Save**.

SETTINGS SCREEN — CONSUMABLES TAB

Entering and Reviewing Consumables Status

The *Consumables* tab includes installation and expiration dates, as well as a real-time status for the days remaining of the Analyzer’s consumables: UV lamp, pump heads, and resin cartridge. This tab also includes buttons for indicating a new consumable has been installed. After entering a new date, the Analyzer automatically updates the installation date, expiration date, and remaining days status.

To indicate a new consumables installation

1. On the *Settings*  screen, press the *Consumables* tab.

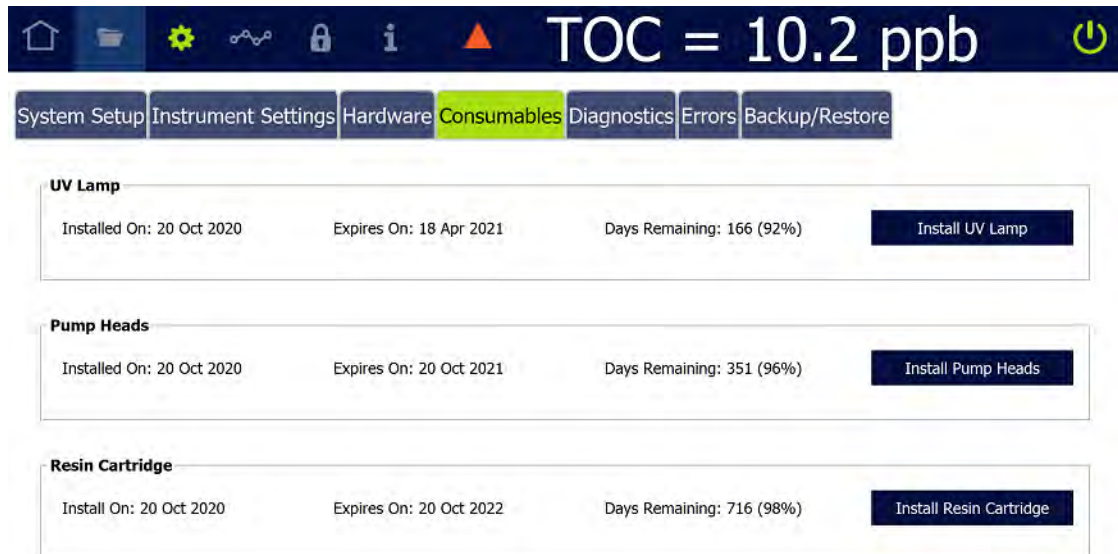

2. In the applicable area (*UV Lamp, Pump Heads, Resin Cartridge*), press one of the following buttons to use the calendar for entering the date the consumable was installed. The installation date, applicable expiration date, and number of days remaining for the life of the consumables automatically appear to the left of the button.
 - Install UV Lamp
 - Install Pump Heads
 - Install Resin Cartridge
3. Repeat the previous step for each consumable replaced.

SETTINGS SCREEN — ERRORS TAB

The *Errors* tab displays the Warning and Error History of the Analyzer. The Analyzer issues two levels of messages:

- **Warnings** — Warnings do not stop TOC measurements, but may indicate that corrective action is required to prevent eventual Analyzer shutdown or loss of data.
- **Errors** — Errors are serious alerts and all errors stop TOC measurements to prevent the collection of erroneous data or to protect the Analyzer from damage. Corrective action should be taken before the Analyzer can resume normal operation.

Step-by-step instructions for acknowledging Warning and Errors are included in [Chapter 7, "Troubleshooting."](#) Descriptions of the the warning and error codes are included in [Appendix C, "Warning and Error Descriptions."](#)

SETTINGS SCREEN — BACKUP/RESTORE TAB

On the *Backup/Restore* tab, you can:

- Manually back up the Analyzer’s database. See [“Backing Up the Database” on page 175](#).
- Configure the Analyzer to back up the database automatically at a specified frequency and time (such as every 7 days at 3:00 am). See [“Scheduling Automatic Database Backups” on page 177](#).
- Manually remove older data from the database after creating a backup file. See [“Archiving the Database” on page 179](#).
- Manually restore the Analyzer’s database. See [“Restoring a Backup” on page 183](#).
- Manually restore system constants. See [“Restoring System Constants” on page 184](#).
For information about backing up system constants, see [“Saving System Constants” on page 148](#).

Backing Up the Database

Use this instruction to make a copy of the database to a USB memory device or a network path for any future database restoration needs. The backup includes both historical data and system constants. All data in the database remains active in the Analyzer.

To back up the database

1. On the *Settings*  screen, press the *Backup/Restore* tab.

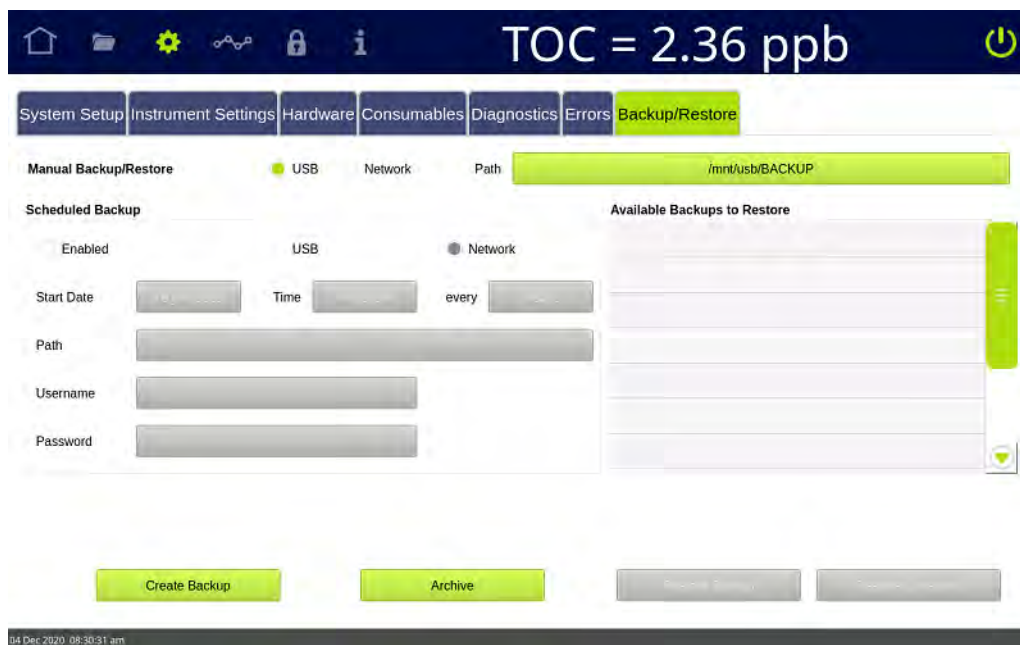

Chapter 4 BASIC ANALYZER OPERATION

2. In the *Manual Backup/Restore* section, select either *USB* or *Network* as the file destination.
3. For **USB**, insert a USB memory device into the USB port.
4. Use the default directory path (for example, */mnt/usb* or */mnt/net*) or click the **PATH** button to specify a different directory path.

If you click the **PATH** button:

- For **USB**, a dialog box for selecting a directory path or creating a folder appears.



Select a directory path or click the **CREATE FOLDER** button to create a sub-folder at the end of the selected directory path.

If you click the **CREATE FOLDER** button, an alphanumeric keypad appears. Type the name of the new folder and click **OK**. The folder appears as a sub-folder at the end of the selected directory path.

- For **Network**, a dialog box for specifying the network path, user name, and password appears.

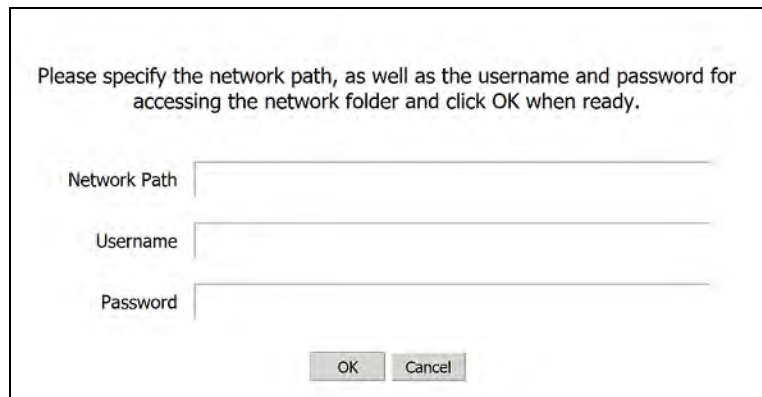
A dialog box with the text: "Please specify the network path, as well as the username and password for accessing the network folder and click OK when ready." Below the text are three input fields labeled "Network Path", "Username", and "Password". At the bottom are "OK" and "Cancel" buttons.

Press within the *Network Path*, *Username*, and *Password* fields, and use the alphanumeric keypad to specify those values. When you finish, press **OK**. A dialog box that includes the specified network path appears.

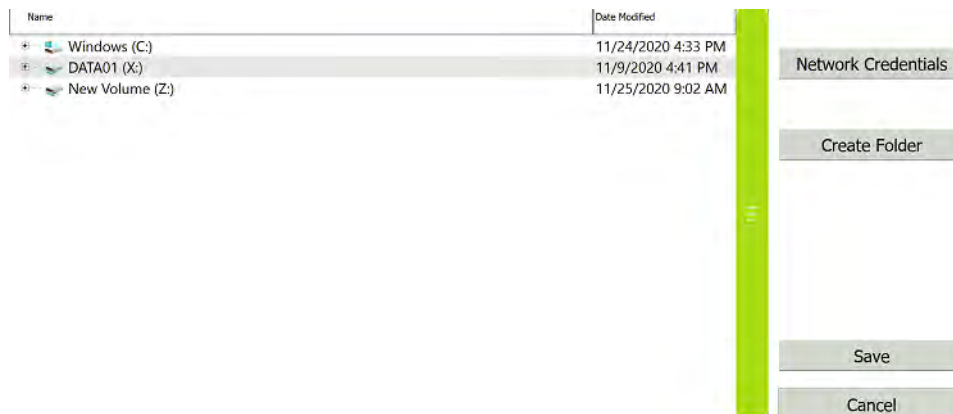

Select the network path.

5. Press **SAVE**.
6. Press **CREATE BACKUP**. A progress bar appears. When the backup is complete, the backup file appears in the *Available Backups to Restore* section and a message that the backup was successfully created appears.



7. Press **OK**.
8. If backing up to a USB memory device, remove it from the USB port.

Scheduling Automatic Database Backups

The Analyzer can automatically back up the database at a specified frequency and time, starting at a specified date. When running a system protocol during the time when a scheduled backup will be run, disable the backup temporarily to prevent any interruption to the system protocol.

To schedule automatic database backups

1. On the *Settings*  screen, press the *Backup/Restore* tab.

Chapter 4 BASIC ANALYZER OPERATION

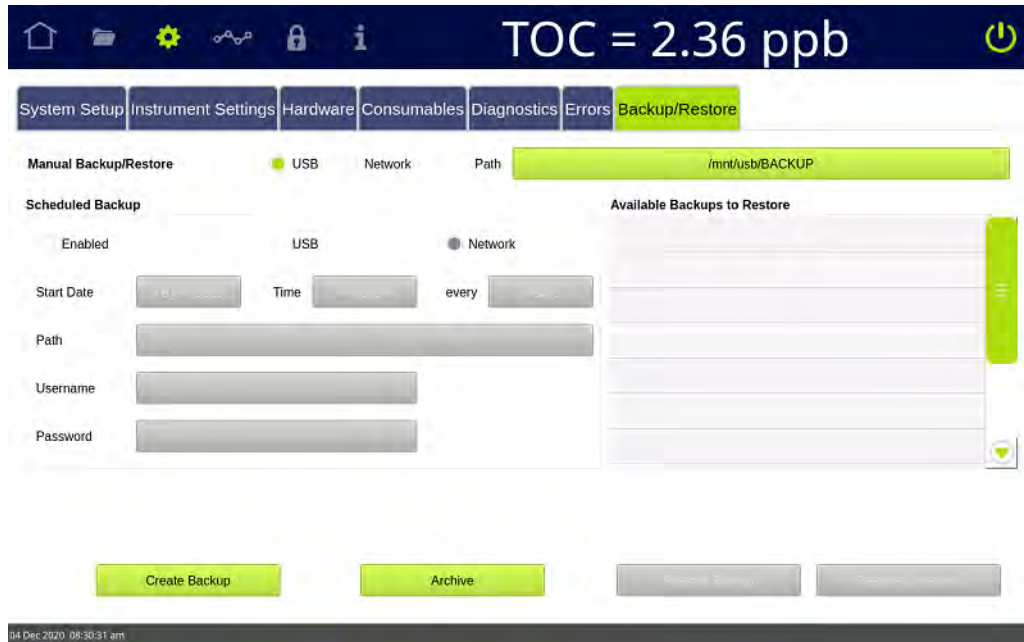

2. In the *Scheduled Backup* section, select the *Enabled* option.
3. In the *Scheduled Backup* section, select either *USB* or *Network* as the file destination.
4. For **USB**, insert a USB memory device into the USB port.
5. Use the default directory path (for example, **/mnt/usb** or **/mnt/net**), or click the **PATH** button to specify a different directory path. A dialog box for selecting a directory path or creating a folder appears.



6. Select a directory path or click the **CREATE FOLDER** button to create a sub-folder at the end of the selected directory path.
If you click the **CREATE FOLDER** button, an alphanumeric keypad appears. Type the name of the new folder and click **OK**. The folder appears as a sub-folder at the end of the selected directory path.



7. Press **SAVE**.
8. Press the *Start Date* field and use the calendar to enter the start date.
9. Press the *Time* field and use the numeric keypad to enter the time (24-hour format) for each automatic backup. For example, entering **2330** sets the time for all scheduled database backups at 11:30 pm.
10. Press the *every* field and use the numeric keypad to enter a value (minimum 1 day and maximum 365 days) for the frequency of the scheduled backups. For example, entering **30** schedules a database backup every 30 days.
11. For **Network**, press within the *Username* and *Password* fields to enter network credentials, and use the alphanumeric keypad to specify those values.

When scheduled backups are enabled, the Analyzer will start the first automatic backup on the start date. If the start date is in the past, the Analyzer will start the first automatic backup at the first scheduled period in the future. For example, on 10 December 2020, a user enables scheduled backups and enters these values in the *Start Date*, *Time*, and *every* fields: **4 Dec 2020**, **22:00**, and **7**. The first automatic backup will start on 11 December 2020 at 10:00 pm.

To disable automatic database backups

If a system protocol is performed during the time frame of an automatically scheduled backup, first temporarily disable the backup to prevent any interruption to the system protocol.

1. On the *Settings*  screen, press the *Backup/Restore* tab.
1. De-select *Enabled* in the *Scheduled Backup* section.
2. When the system protocol is complete, select *Enabled* in the *Scheduled Backup* section. If needed, run a manual backup.

Archiving the Database

Use this instruction to back up the Analyzer's database to a USB memory device or a network path and at the same time remove older data from the database.

For example, on 1 December 2020 a user archives the database and specifies that 3 months of historical data should be retained. Before the Archive is run, the database contains 12 months of historical data (1 December 2019 through 1 December 2020). When the Archive is run, the Analyzer creates a backup file containing all the data in the database (1 December 2019 through 1 December 2020) and removes historical data from 1 December 2019 through 31 August 2020 from the database. The Analyzer's database then contains data from 1 September 2020 through 1 December 2020.

Chapter 4 BASIC ANALYZER OPERATION



NOTE: When the Archive is complete, the Analyzer must be restarted. Before starting the Archive process, finish running any process that should not be interrupted, such as a system protocol.

To archive the database

1. On the **Settings**  screen, press the **Backup/Restore** tab.
2. In the **Manual Backup/Restore** section, select either **USB** or **Network** as the destination of the backup file created during the Archive process.
3. For **USB**, insert a USB memory device into the USB port.
4. Use the default directory path (for example, **/mnt/usb** or **/mnt/net**) or click the **PATH** button to specify a different directory path.

If you click the **PATH** button:

- For **USB**, a dialog box for selecting a directory path or creating a folder appears.



Select a directory path or click the **CREATE FOLDER** button to create a sub-folder at the end of the selected directory path.

If you click the **CREATE FOLDER** button, an alphanumeric keypad appears. Type the name of the new folder and click **OK**. The folder appears as a sub-folder at the end of the selected directory path.



- For **Network**, a dialog box for specifying the network path, user name, and password appears.

Please specify the network path, as well as the username and password for accessing the network folder and click OK when ready.

Network Path

Username

Password

OK Cancel

Press within the *Network Path*, *Username*, and *Password* fields, and use the alphanumeric keypad to specify those values. When you finish, press **OK**. A dialog box with the specified network path appears.



Select the network path.

5. Press **SAVE**.
6. Press **CREATE ARCHIVE**. A dialog box for specifying the months of history data to retain appears.

Months of History Data To Retain (2-60):

2

7 8 9

4 5 6

1 2 3

0 Backspace

OK Cancel

7. Specify the number of months of history data to retain in the Analyzer's database.

For example, on 15 December 2020, a user archives the database and retains **2** months of history data. The Analyzer retains all history data from 15 October 2020 through 15 December 2020. History data older than 15 October 2020 is removed from the Analyzer's database. All history data (including history data older than 15 October 2020) is included in the backup file.

8. Press **OK**. A progress bar appears. When the archive is complete, the backup file appears in the *Available Backups to Restore* section. A message appears stating that the database was successfully archived and the Analyzer's' firmware must be restarted.

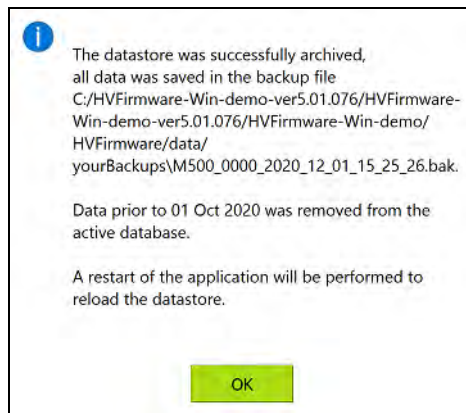

9. Press **OK** to restart the Analyzer's firmware. When the initialization process is complete, the *Home*  screen appears.

Restoring a Backup

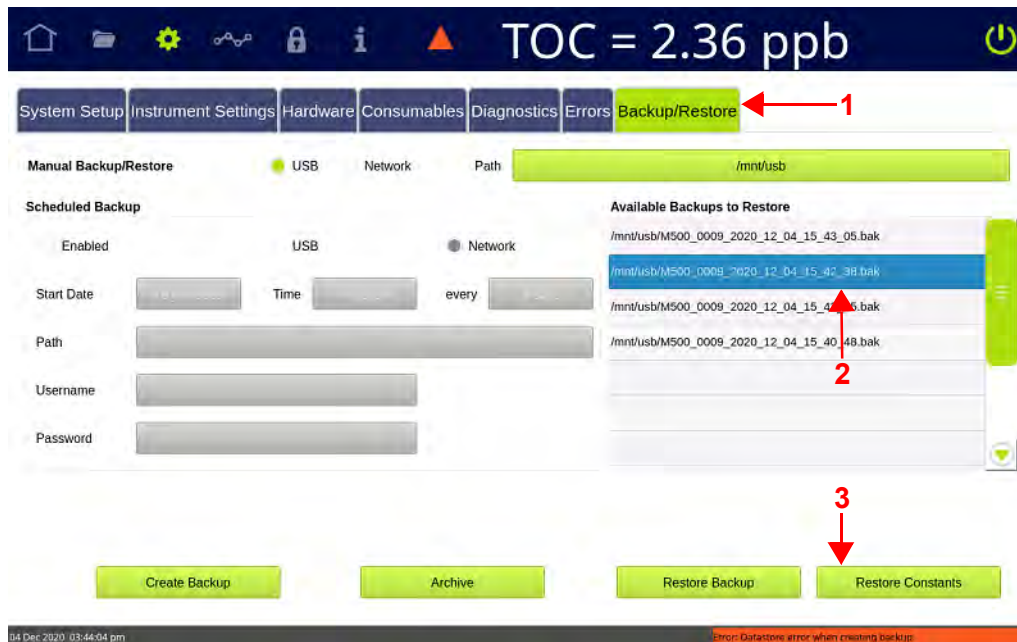

To restore a backup of the database

1. On the *Settings*  screen, press the *Backup/Restore* tab.

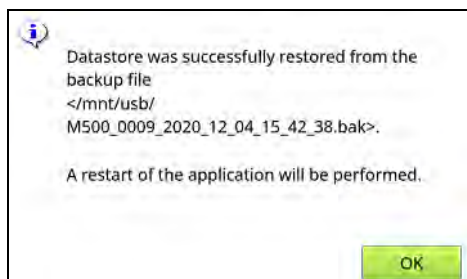

2. In the *Available Backups to Restore* section, select the backup to restore.
3. Press **RESTORE BACKUP**. A progress bar appears, and the current database is backed up prior to restoring the selected backup. When the process is complete, a message appears stating that the database was successfully restored and the Analyzer's firmware must be restarted.



4. Press **OK** to restart the Analyzer's firmware. When the initialization process is complete, the *Home*  screen appears. The *Available Backups to Restore* section of the *Backup/Restore* tab on the *Settings*  screen includes the new backup file.

Restoring System Constants

System constants are backed up along with the historical data in the Analyzer's database and stored in backup files. To restore the system constants in a backup file — but not the historical data in the file — use the *Restore Constants* option.

To restore system constants

1. On the *Settings*  screen, press the *Backup/Restore* tab.
2. In the *Available Backups to Restore* section, select the backup file containing the system constants to restore.
3. Press **RESTORE CONSTANTS**. A progress bar appears while the system constants are restored.

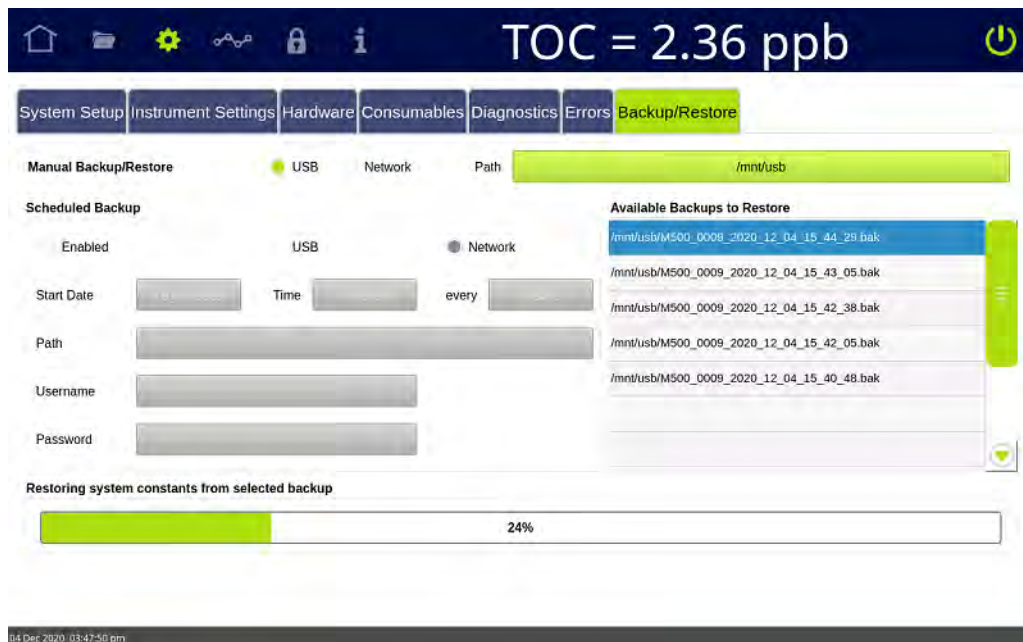

4. When the process is complete, a message appears stating that the system constants were successfully restored from the selected backup file, and the Analyzer's' firmware must be restarted.
5. Press **OK** to restart the Analyzer's firmware. When the initialization process is complete, the *Home*  screen appears.

THE DATA SCREEN



The Data screen includes the data history for online analysis and grab sampling.

Reviewing Data History

This section includes step-by-step instructions for filtering, viewing, printing, and exporting data history records:

- [“To review data history for Online Methods” on page 185](#)
- [“To review data history for System Protocols and Grab Methods” on page 188](#)

To review data history for Online Methods

1. On the *Data*  screen, select the *Online Data* tab. A trend graph for the specified data appears.



Chapter 4 BASIC ANALYZER OPERATION

- To change the color of the background and/or the size of the data points, see [“To change the display of data on the trend graph” on page 127](#). The example shows a trend graph with a black background and 7-pixel data points.



- To display the online data in table view, press the *Table View*  icon.

The screenshot shows the HV analyzer interface with the online data displayed in table view. The top bar displays 'TOC = 5.60 ppb'. Below the table, there are controls for Start Time (08 Dec 2020 12:00) and End Time (08 Dec 2020 13:00). The table has columns for Timestamp, TOC, IC, and TC. There are buttons for 'Export All', 'Print', and 'Export' at the bottom.

	Timestamp	TOC	IC	TC
Online	08 Dec 2020 12:01:32	3.80 ppb	4.95 ppb	8.75 ppb
Online	08 Dec 2020 12:04:32	2.45 ppb	4.30 ppb	6.75 ppb
Online	08 Dec 2020 12:07:32	4.10 ppb	5.65 ppb	9.75 ppb
Online	08 Dec 2020 12:10:32	2.75 ppb	5.00 ppb	7.75 ppb
Online	08 Dec 2020 12:13:32	4.40 ppb	6.25 ppb	10.7 ppb
Online	08 Dec 2020 12:16:32	3.05 ppb	5.70 ppb	8.75 ppb
Online	08 Dec 2020 12:19:32	4.70 ppb	7.05 ppb	11.7 ppb
Online	08 Dec 2020 12:22:32	3.35 ppb	6.40 ppb	9.75 ppb
Online	08 Dec 2020 12:25:32	5.00 ppb	7.75 ppb	12.7 ppb
Online	08 Dec 2020 12:28:32	3.65 ppb	7.10 ppb	10.7 ppb
Online	08 Dec 2020 12:31:32	5.30 ppb	8.45 ppb	13.7 ppb
Online	08 Dec 2020 12:34:32	3.95 ppb	7.80 ppb	11.7 ppb
Online	08 Dec 2020 12:37:32	5.60 ppb	9.15 ppb	14.7 ppb



To return to the view of the data as a trend graph, press the *Trend Graph*  icon.

4. Enter filter parameters for data to view:
 - Start Time (Date) — Press in the *Start Time* field on the left and use the calendar to enter the beginning date of data history to include.
 - Start Time (Time of Day) — Press in the *Start Time* field on the right and use the numeric keypad to enter the beginning time of data history to include.
 - End Time (Date) — Press in the *End Time* field on the left and use the calendar to enter the ending date of data history to include. The time range can be at most two months.
 - End Time (Time of Day) — Press in the *End Time* field on the right and use the numeric keypad to enter the ending time of data history to include.
5. Select one or more of the following data types to include (The conductivity fields **only** appear if the Analyzer is configured with the *Sample Conductivity* option.):
 - TOC
 - IC
 - TC
 - iCond
 - tCond
 - Temp
6. Press **APPLY**. The online data meeting the applied filter parameters appears on the graph or in the table.
7. To view details of the analysis, select a line in the table and press **DETAILS**.
8. To print or export data history for a record in the table, select a line and press the appropriate button (**PRINT** or **EXPORT**).



NOTE: For more information about printing and exporting from an Analyzer screen, refer to [“Printing and Exporting from the Analyzer Screens” on page 123](#)

9. To print or export all the system protocol and grab data history that meets the applied filter parameters, press **PRINT ALL** or **EXPORT ALL**.
10. To conduct a new search, press **RESET FILTER** to clear the current search parameters and data, and then repeat steps [4](#) through [6](#).

Chapter 4 BASIC ANALYZER OPERATION

To review data history for System Protocols and Grab Methods

1. On the *Data*  screen, select the *System Protocols and Grab Methods Data* tab.

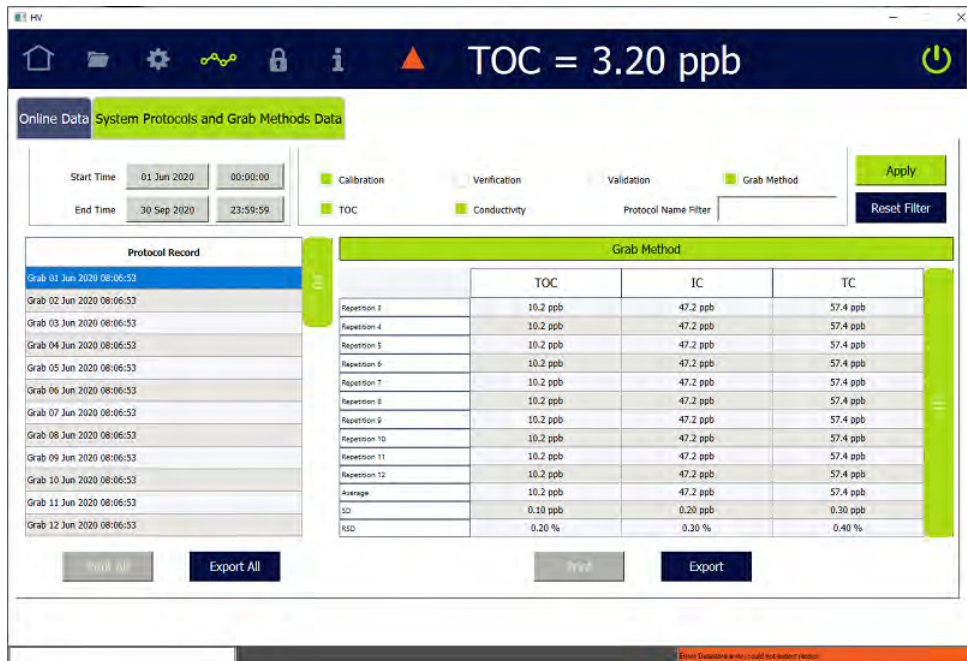

	TOC	IC	TC
Repetition 1	10.2 ppb	47.2 ppb	57.4 ppb
Repetition 2	10.2 ppb	47.2 ppb	57.4 ppb
Repetition 3	10.2 ppb	47.2 ppb	57.4 ppb
Repetition 4	10.2 ppb	47.2 ppb	57.4 ppb
Repetition 5	10.2 ppb	47.2 ppb	57.4 ppb
Repetition 6	10.2 ppb	47.2 ppb	57.4 ppb
Repetition 7	10.2 ppb	47.2 ppb	57.4 ppb
Repetition 8	10.2 ppb	47.2 ppb	57.4 ppb
Repetition 9	10.2 ppb	47.2 ppb	57.4 ppb
Repetition 10	10.2 ppb	47.2 ppb	57.4 ppb
Repetition 11	10.2 ppb	47.2 ppb	57.4 ppb
Repetition 12	10.2 ppb	47.2 ppb	57.4 ppb
Average	10.2 ppb	47.2 ppb	57.4 ppb
SD	0.10 ppb	0.20 ppb	0.30 ppb
STD	0.20 %	0.30 %	0.40 %

2. Enter filter parameters for data to view:
 - Start Time (Date) — Press in the *Start Time* field on the left and use the calendar to enter a beginning date of data history.
 - End Time (Date) — Press in the *End Time* field on the left and use the calendar to enter an ending date of data history.
 - Start Time (Time of Day) — Press in the *Start Time* field on the right and use the numeric keypad to enter a beginning time of data history.
 - End Time (Time of Day) — Press in the *End Time* field on the right and use the numeric keypad to enter an ending time of data history.
3. Do one or more of the following:
 - To search by protocol name, press inside the *Protocol Name Filter* field and use the alphanumeric keypad to enter all or part of a protocol record, which includes the name and time stamp.

- Select one or more the following data types to include:
 - Calibration
 - Verification
 - Validation
 - Grab Method
 - TOC
 - Conductivity
4. Press **APPLY**. The system protocol and grab method data meeting the applied filter parameters appears in the table.
 5. To view details of the analysis, select a line in the table. Details of the analysis appear to the right.
 6. To print or export data history for a record in the table, select a line and press the appropriate button (**PRINT** or **EXPORT**).



NOTE: For more information about printing and exporting from an Analyzer screen, refer to [“Printing and Exporting from the Analyzer Screens” on page 123](#)

7. To print or export all the system protocol and grab data history, press **PRINT ALL** or **EXPORT ALL**.
8. To conduct a new search, press **RESET FILTER** to clear the current search parameters and data, and then repeat steps [2](#) through [4](#).

THE DATAGUARD SCREEN



The Sievers M500 TOC Analyzer offers one of two levels of security, *Password Protection* and *DataGuard*. Enable **only one** of these security features, but not both.

The *Password Protection* feature is included with all Analyzers and provides a basic level of security. To enable *Password Protection*, refer to [Chapter 5. "Enabling Password Protection."](#)

The *DataGuard* feature is available as an option and provides support for signing records in compliance with regulation 21 CFR Part 11. To activate the DataGuard option, see [“Activating Options” on page 155](#). For more extensive *DataGuard* configuration instructions, and additional information about *Password Protection* and *DataGuard*, refer to [Chapter 5. "Password Protection and DataGuard."](#)

THE HELP SCREEN



The *Help* screen provides reference information about the Analyzer's system, including application and system board firmware versions, any IOS or Super IOS system, and operating system. The Analyzer's IP address and unique key are also included. This key number may be requested by Technical Support or your local service provider when providing technical assistance.

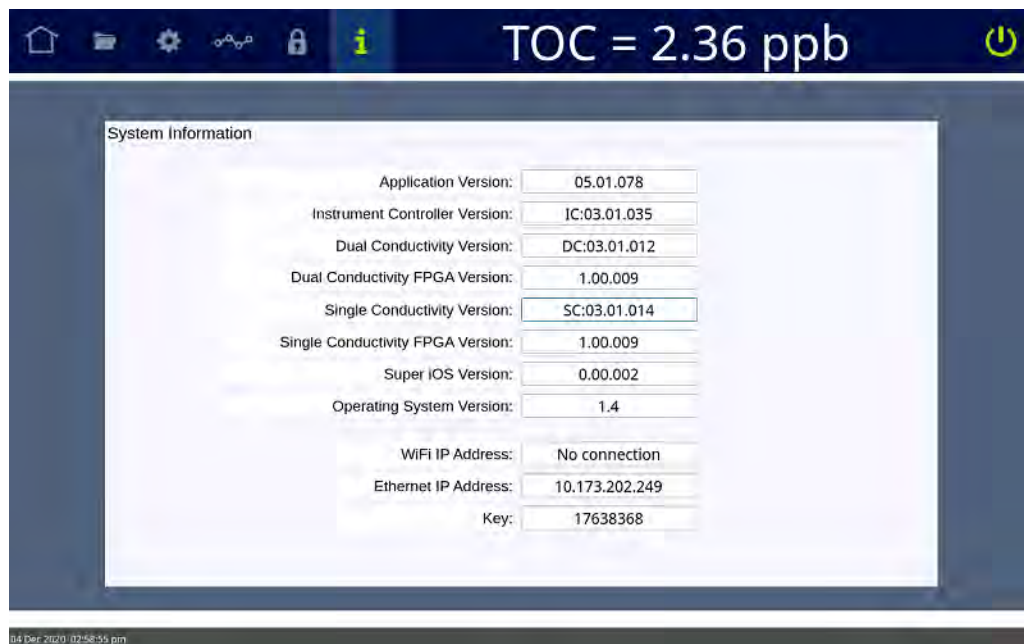

5

PASSWORD PROTECTION AND DATAGUARD

.....

OVERVIEW

The Sievers M500 TOC Analyzer offers two levels of security, *Password Protection* and *DataGuard*. Enable **only one** of these security features, but not both.

The *Password Protection* feature is included with all Analyzers and provides a basic level of security. To enable *Password Protection*, refer to [“Enabling Password Protection” on page 191](#).

The *DataGuard* feature is available as an option and provides support for signing records in compliance with regulation 21 CFR Part 11. To activate the DataGuard option, see [“Activating Options” on page 155](#). For more extensive *DataGuard* configuration instructions, and additional information about *Password Protection* and *DataGuard*, refer to this chapter.

PASSWORD PROTECTION

This section provides information about using and enabling Password Protection.

Using Password Protection

To ensure that only authorized personnel access the Analyzer, assign one password that all users must enter before starting and stopping analysis or gaining access to menu screens.

Enabling Password Protection

The same password will be required of all users. Any user using this password can change the password, as needed, to comply with internal security policies.



NOTE: *If you are planning to activate DataGuard, there is no need to additionally activate this Password Protection feature. Instead, go to the next section, [“Enabling DataGuard.”](#)*

This section provides these instructions:

- [“To enable Password Protection” on page 192](#)
- [“To log in using Password Protection” on page 193](#)
- [“To change the password” on page 193](#)
- [“To disable Password Protection” on page 193](#)

To enable Password Protection

1. Go to the *DataGuard*  screen.
2. Select the *Enable Security Password* option.

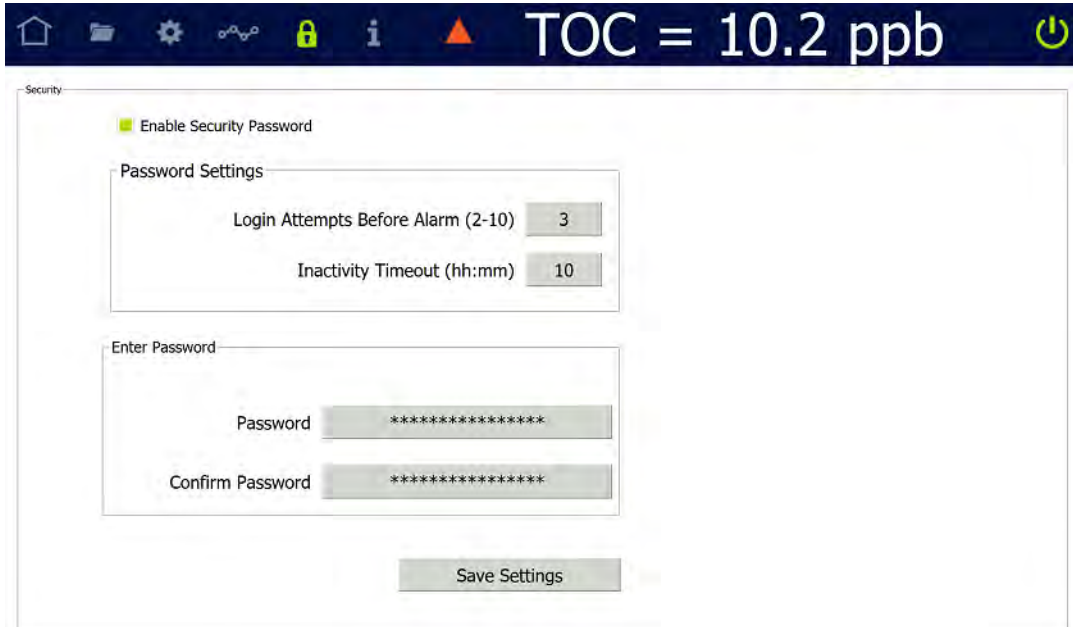

Security

Enable Security Password

Password Settings

Login Attempts Before Alarm (2-10) 3

Inactivity Timeout (hh:mm) 10

Enter Password

Password *****

Confirm Password *****

Save Settings

3. Complete the following:
 - Login Attempts Before Alarm (2-10)
 - Inactivity Timeout (hours and minutes) — The minimum timeout is one (1) minute.
4. Press the *Password* field and use the alphanumeric keypad to enter a password.
5. Confirm the Password.
6. Press **SAVE SETTINGS**.
7. Record the new password in a secure location. ALL users will be required to enter this log in information to access the Analyzer’s menus.



To log in using Password Protection

1. Power on the Analyzer. The touchscreen illuminates and displays the splash screen during the system initialization process. When initialization is complete, the *Home*  screen appears.
2. Press the **LOGIN** button near the bottom right of the screen. The *Login* dialog box appears.

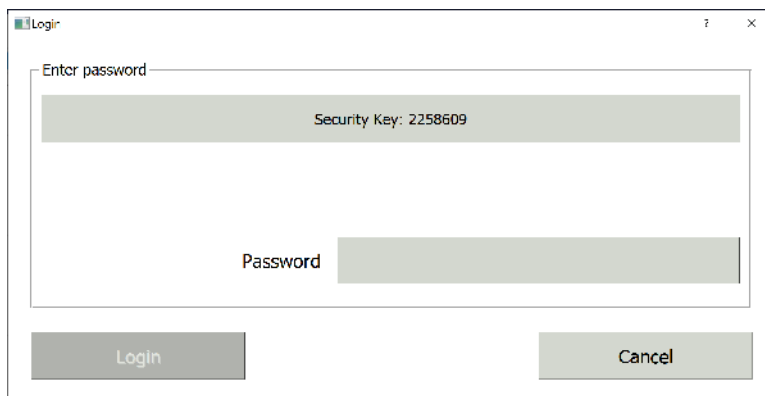

3. Press the *Password* field and use the alphanumeric keypad to enter a password.
4. Press **LOGIN**.

To change the password

1. Go to the *DataGuard*  screen.
2. Press the *Password* field and use the alphanumeric keypad to enter a new password.
3. Confirm the Password.
4. Press **SAVE SETTINGS**. The password you entered will overwrite the previous password.

To disable Password Protection

1. Go to the *DataGuard*  screen.
2. De-select the *Enable Security Password* option.
3. Press **SAVE SETTINGS**.

DATAGUARD

DataGuard offers support for regulation 21 CFR Part 11, providing multiple levels of user access to the Analyzer via up to 100 unique User IDs and maintaining an audit trail of all user operations. DataGuard must be purchased as an upgrade from SUEZ. After it is enabled, it cannot be disabled.

Enabling DataGuard

To use DataGuard, first activate DataGuard on the Analyzer, as explained in [Chapter 3, "Installation"](#) ("[Activating DataGuard \(Optional\)](#)" on page 91). SUEZ highly recommends that you create a new administrator account and make the default administrator account inactive, as explained in the following steps.

Logging into DataGuard

To log into DataGuard





NOTE: *If the unsuccessful number of login attempts exceeds the configured setting (2-10), the Analyzer will automatically deactivate the User ID. In this case, the Administrator (or another user with an Access Level that has been assigned the Edit User Role) can reset the Status to the User ID to active.*

1. If the Analyzer is off, power it on. The touchscreen illuminates and displays the splash screen during the system initialization process. When initialization is complete, the *Home*  screen appears with a **LOGIN** button.

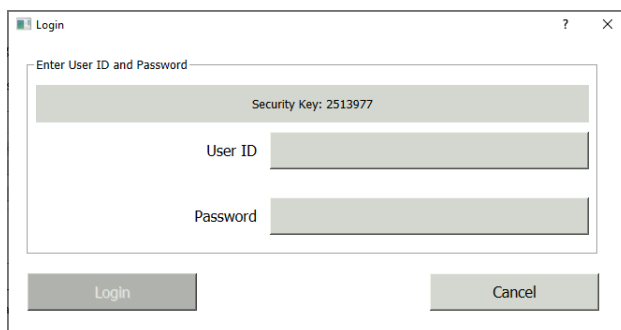

2. Press the **LOGIN** button. The *Login* dialog box appears.



3. Press inside the *User ID* field and use the alphanumeric keypad to enter your User ID.
4. Press inside the *Password* field and use the alphanumeric keypad to enter your password.
5. Press the **LOGIN** button on the *Login* dialog box. The Analyzer outlines the *Home*  screen icon in green and replaces the **LOGIN** button on the screen with a **LOG OUT** button.

Managing User Accounts

After DataGuard is enabled, the DataGuard Administrator (or another user with an Access Level that has been assigned the *Edit User Role*) gives each user access to the Analyzer. To grant access, the Administrator creates a User ID for the user and assigns the User ID a password. The administrator also assigns the User ID an Access Level and makes the status *active*.

- *Access Level* — Indicates the level of access a user has to various Analyzer functions. Three Access Levels are provided:
 - *Administrator* (default for all new User IDs), which has access to all Analyzer functions
 - *Supervisor*, which has access to fewer Analyzer functions than *Administrator*
 - *Operator*, which has access to fewer Analyzer functions than *Supervisor*

Administrators can create their own Access Levels by assigning Roles, such as *Run Calibration* and *Backup Data*, to them. Administrators can change the roles assigned to any Access Level, including the three provided when DataGuard is activated. For more information, refer to [“Creating and Revising Access Levels” on page 200](#).

- *User Status* — Indicates whether the User ID is *active* (default for all new User IDs), *password expired*, *inactive*, or *retired*. Users with User IDs that have a status of *password expired*, *inactive*, or *retired* cannot log in to the Analyzer.
 - If a user account is *inactive* or *retired*, the administrator must reset the User ID to *active* before that user can log in. Note that if a user exceeds the permitted number of unsuccessful login attempts, the account is automatically set to *inactive*. For more information, see [“To configure login settings” on page 205](#).
 - If a user account is *password expired* and the user’s assigned Access Level includes the *Change Password* role, the user can reset the expired password. Otherwise, the user must contact a System Administrator.

This section includes instructions for the following:

- [“To add a User ID” on page 196](#)
- [“To edit a User Account” on page 198](#)
- [“To export a list of users” on page 198](#)

To add a User ID

1. On the *DataGuard*  screen, select the *User List* tab.

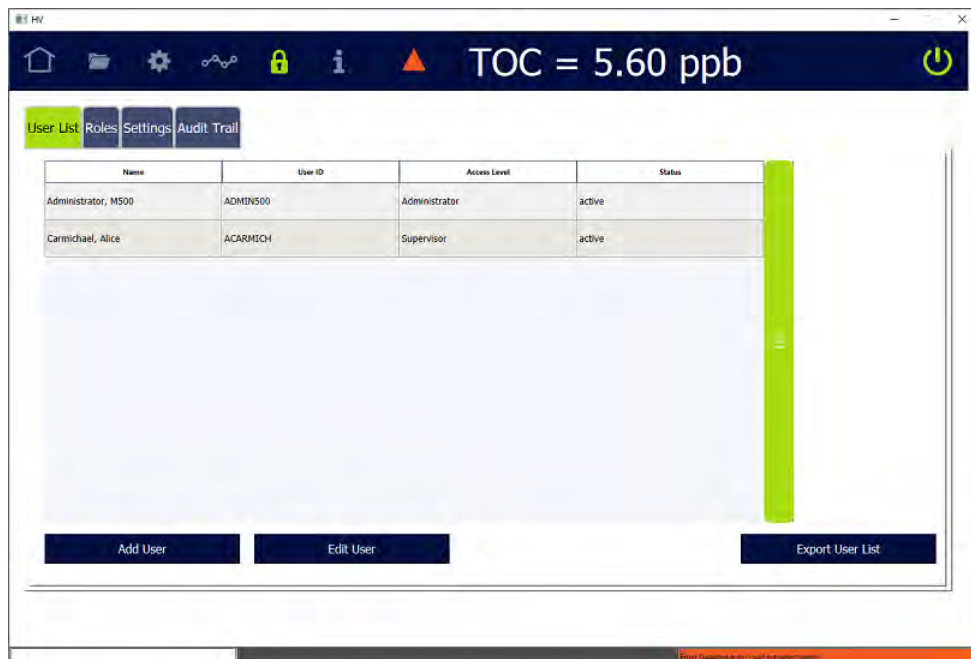

2. Press **ADD USER**. The *User Setup* dialog box appears.

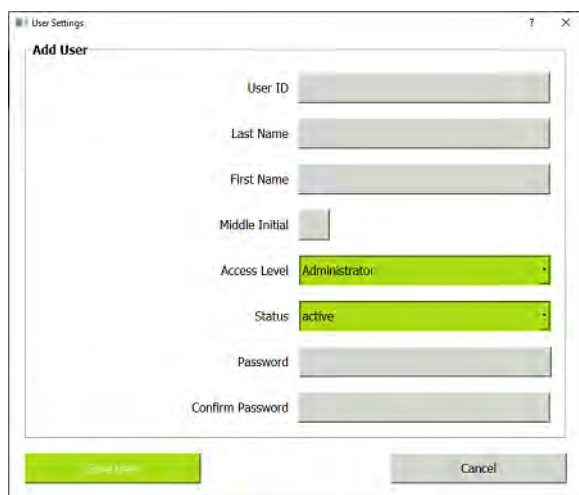

3. Complete the following by pressing inside each field and use the keypad to enter:

- User ID
- Last Name
- First Name
- Middle Initial (optional)



NOTE: After you save a User ID, the User ID and name cannot be modified.

4. Select an access level from the *Access Level* list.

5. Press inside the *Password* field and use the alphanumeric keypad to enter a password.
6. Press inside the *Confirm Password* field and use the keypad to re-enter the password.
7. Verify the *Status* list is set to **Active**.
8. Press **SAVE USER**.



NOTE: If this is the first user account created upon initial DataGuard Software activation, the default minimum requirements for the password are: one uppercase letter and one number. After the first user account is established, the minimum password requirement settings are configurable. For more information about DataGuard password settings, see [“To configure login settings” on page 205](#).



NOTE: To help a new user remember the password, and to ensure security, require a new user to change the Password upon login. For information about how users can change their passwords, see [“To change your DataGuard password if your Access Level has the Change Password role” on page 207](#).

To edit a User Account

1. On the *DataGuard*  screen, select the *User List* tab.
2. Select the line with the User ID to modify.
3. Press **EDIT USER**. The *User Settings* dialog box appears.
4. Enter a new password and/or select a new Access Level or Status, as needed.
5. Press **SAVE USER**.

To export a list of users

1. On the *DataGuard*  screen, select the *User List* tab.
2. Press **EXPORT USER LIST**.
3. Follow the instructions in [“To export from an Analyzer screen” on page 124](#).



Table 6: Record of User IDs

User ID	User's Name	Date Created	Date Archived

Creating and Revising Access Levels

The Analyzer is pre-configured with three Access Levels:

- Administrator (initially includes all roles)
- Supervisor
- Operator

This section includes the following instructions:

- [“To create a new Access Level with assigned Roles” on page 200](#)
- [“To edit assigned user roles” on page 201](#)

To reference the available roles and related abilities, see [“Roles and Role Abilities” on page 202](#).

To create a new Access Level with assigned Roles

Use this procedure to establish a new Access Level (such as for a Lab Manager) and assign Roles to it, defining areas of access and which tasks can be performed within the Analyzer. For more information on available roles, see [Table 7 “Roles and Role Abilities” on page 202](#).

1. On the *DataGuard*  screen, select the *Roles* tab.

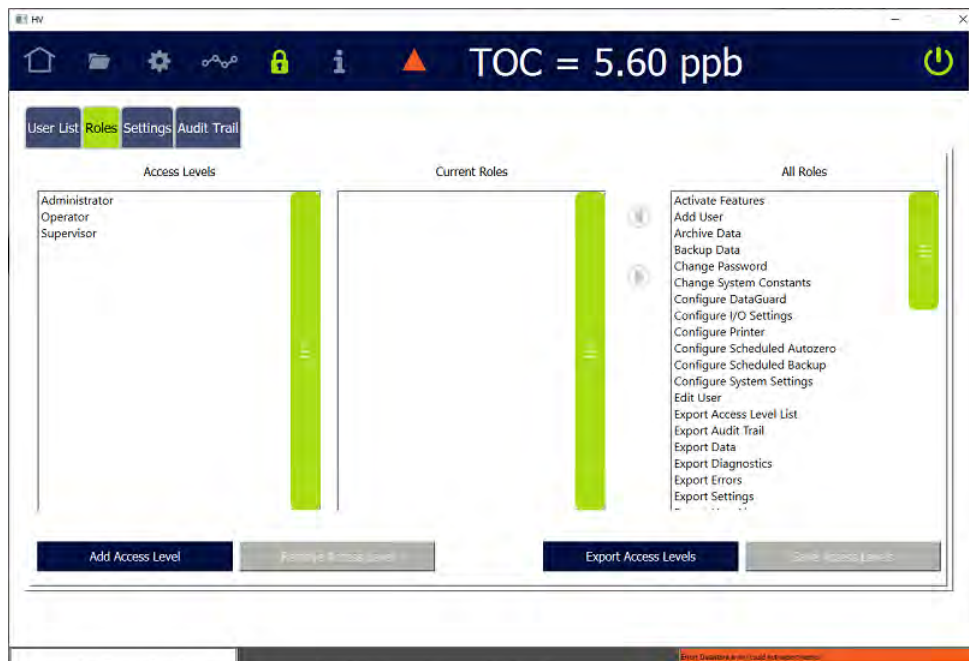

2. Press **ADD ACCESS LEVEL**, use the alphanumeric keypad to type the name of a new Access Level, and press **OK**.
3. To change the roles assigned to an Access Level, select the Access Level. The assigned appear in the Current Roles pane.

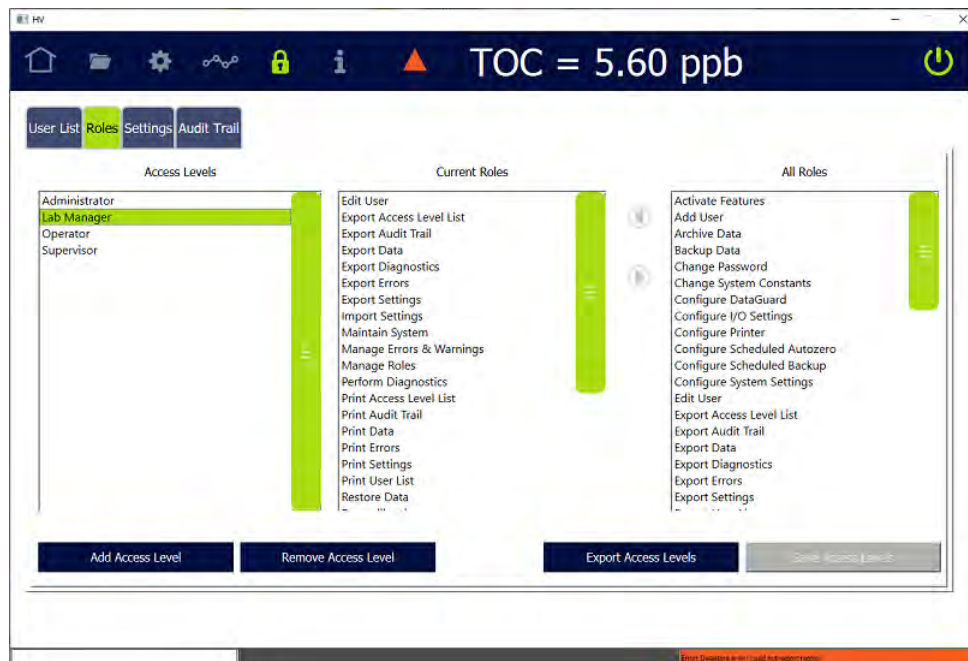

4. To assign a role to the Access Level, select a role in the *All Roles* pane and press the right arrow to copy it to the *Current Roles* pane.
5. To remove a role from the *Current Roles* pane, select it and click the left arrow.
6. Repeat the previous steps [4](#) and [5](#), as needed.
7. Click **SAVE ACCESS LEVELS** to save.

To edit assigned user roles

Use this procedure to revise roles assigned to an established Access Level, by adding a new role(s) or removing an existing role(s). For more information on available roles, see [Table 7 “Roles and Role Abilities” on page 202](#)

1. On the *DataGuard*  screen, select the *Roles* tab.
2. Select the Access Level to modify.
3. To assign a role to the Access Level, select a role in the *All Roles* pane and press the right arrow to copy it to the *Current Roles* pane.
4. To remove a role from the *Current Roles* pane, select it and click the left arrow.
5. Repeat the previous steps [3](#) and [4](#), as needed.
6. Click **SAVE ACCESS LEVELS** to save.

TABLE 7: ROLES AND ROLE ABILITIES

<i>Role Names</i>	<i>Role Abilities</i>
Activate Features	<ul style="list-style-type: none"> On <i>Settings > Instrument Settings</i> tab, activate one or more Analyzer options, such as DataGuard, Sample Conductivity, Performance Qualification (PQ) Protocols, and 3 Minute Analysis.
Add User	<ul style="list-style-type: none"> On <i>DataGuard > User List</i> tab, add users.
Archive Data	<ul style="list-style-type: none"> On <i>Settings > Backup/Restore</i> tab, manually back up and restore data.
Backup Data	<ul style="list-style-type: none"> On <i>Settings > Backup/Restore</i> tab, manually back up data.
Change Password	<ul style="list-style-type: none"> On <i>DataGuard > User List</i> tab, change your password.
Change System Constants	<ul style="list-style-type: none"> On <i>Settings > Instrument Settings</i> tab > <i>System Constants</i> area, change values of system constants.
Configure DataGuard	<ul style="list-style-type: none"> On <i>DataGuard > Settings</i> tab, specify password settings, User ID settings, inactivity timeout, login attempts before account is suspended.
Configure I/O Settings	<ul style="list-style-type: none"> On <i>Settings > Hardware</i> tab, configure values for <i>Alarms Setup, Analog Outputs Setup, Binary Inputs Setup, Ethernet Setup, Flow Sensor Setup, Level Sensor Setup, and UV Lamp Setup.</i>
Configure Printer	<ul style="list-style-type: none"> On <i>Settings > Hardware</i> tab, configure PDF printer connected to Analyzer directly or over Ethernet network.
Configure Scheduled Autozero	<ul style="list-style-type: none"> On <i>Protocols > System Protocols</i> tab > <i>Calibration</i> tab, set up schedule for running TC/IC Conductivity Autozero and TOC Autozero protocols.
Configure Scheduled Backup	<ul style="list-style-type: none"> On <i>Settings > Backup/Restore</i> tab, <i>Scheduled Backup</i> area, configure values. Also manually back up and restore data.
Configure System Settings	<ul style="list-style-type: none"> On <i>Settings > System Setup</i> tab > <i>Local Settings</i> area, configure values in <i>Environment, Display Formats, and Screen</i> areas (but not <i>Pharmacopoeia</i>).
Edit User	<ul style="list-style-type: none"> On <i>DataGuard > User List</i> tab, edit user's Access Level and/or Status.



Role Names	Role Abilities
Export Access Level List	<ul style="list-style-type: none"> On <i>DataGuard</i> > <i>Roles</i> tab, export list of Access Levels.
Export Audit Trail	<ul style="list-style-type: none"> On <i>DataGuard</i> > <i>Audit Trail</i> tab, export Audit Trail.
Export Data	<ul style="list-style-type: none"> On <i>Data</i> screen, export displayed data.
Export Diagnostics	<ul style="list-style-type: none"> On <i>Settings</i> > <i>Diagnostics</i> tab, export diagnostic data.
Export Errors	<ul style="list-style-type: none"> On <i>Settings</i> > <i>Errors</i> tab, export list of errors.
Export Settings	<ul style="list-style-type: none"> On <i>Settings</i> > <i>Instrument Settings</i> tab > <i>Analyzer Settings</i> area, export Analyzer settings.
Export User List	<ul style="list-style-type: none"> On <i>DataGuard</i> > <i>User List</i> tab, export list of users.
Import Settings	<ul style="list-style-type: none"> On <i>Settings</i> > <i>Instrument Settings</i> tab > <i>Analyzer Settings</i> area, import Analyzer settings.
Maintain Consumables	<ul style="list-style-type: none"> On <i>Settings</i> > <i>Consumables</i> tab, indicate that UV lamp, pump heads, and/or resin cartridge has been installed or replaced.
Maintain System	<ul style="list-style-type: none"> On <i>Settings</i> > <i>Hardware</i> tab, run <i>Instrument Startup Wizard</i>. Also configure values for <i>Accelerated Rinse</i>, <i>Analog Output Calibration</i>, <i>Backflush</i>, <i>Drain Instrument</i>, and <i>Flush Super iOS</i>.
Manage Errors and Warnings	<ul style="list-style-type: none"> On <i>Settings</i> > <i>Errors</i> tab, view and acknowledge errors.
Manage Roles	<ul style="list-style-type: none"> On <i>DataGuard</i> > <i>Roles</i> tab, add Access Levels, add roles to and remove them from Access Levels, remove Access Levels.
Perform Diagnostics	<ul style="list-style-type: none"> On <i>Settings</i> > <i>Diagnostics</i> tab, run diagnostic tests.
Print Access Level List	<ul style="list-style-type: none"> On <i>DataGuard</i> > <i>Roles</i> tab, print list of Access Levels.
Print Audit Trail	<ul style="list-style-type: none"> On <i>DataGuard</i> > <i>Audit Trail</i> tab, print Audit Trail.
Print Data	<ul style="list-style-type: none"> On <i>Data</i> screen, print displayed data.
Print Errors	<ul style="list-style-type: none"> On <i>Settings</i> > <i>Errors</i> tab, print list of displayed errors.
Print Settings	<ul style="list-style-type: none"> On <i>Settings</i> > <i>Instrument Settings</i> tab > <i>Analyzer Settings</i> area, print Analyzer settings.

Chapter 5 PASSWORD PROTECTION AND DATAGUARD

<i>Role Names</i>	<i>Role Abilities</i>
Print User List	<ul style="list-style-type: none"> On <i>DataGuard</i> > <i>User List</i> tab, print list of users.
Restore Data	<ul style="list-style-type: none"> On <i>Settings</i> > <i>Backup/Restore</i> tab, restore backup of data.
Run Calibration	<ul style="list-style-type: none"> On <i>Protocols</i> > <i>System Protocols</i> tab > <i>Calibration</i> tab, run all protocols
Run Grab Sample	<ul style="list-style-type: none"> On <i>Home</i> screen or <i>Protocols</i> > <i>User Defined Methods</i> tab, run user-defined grab methods.
Run Online	<ul style="list-style-type: none"> On <i>Home</i> screen or <i>Protocols</i> > <i>User Defined Methods</i> tab, run user-defined online, online averaged, and online timed methods.
Run System Suitability	<ul style="list-style-type: none"> On <i>Protocols</i> > <i>System Protocols</i> tab > <i>Validation</i> tab, run SDBS Suitability and SDBS Suitability with Conductivity protocols.
Run Validation	<ul style="list-style-type: none"> On <i>Protocols</i> > <i>System Protocols</i> tab > <i>Validation</i> tab, run all protocols except for SDBS Suitability and SDBS Suitability with Conductivity.
Run Verification	<ul style="list-style-type: none"> On <i>Protocols</i> > <i>System Protocols</i> tab > <i>Verification</i> tab, run all protocols.
Set System Clock	<ul style="list-style-type: none"> On <i>Settings</i> > <i>System Setup</i> tab > <i>Local Settings</i> area, set date, time, time zone, and <i>Internet Time Sync</i> option.
Setup Export Preferences	<ul style="list-style-type: none"> On <i>Settings</i> > <i>System Setup</i> tab, specify preferences for exporting data.
Setup Grab Sample	<ul style="list-style-type: none"> On <i>Protocols</i> > <i>User Defined Methods</i> tab, add, edit, and delete user-defined grab methods.
Setup Online Method	<ul style="list-style-type: none"> On <i>Protocols</i> > <i>User Defined Methods</i> tab, add, edit, and delete user-defined online, online averaged, and online timed methods.
Setup Pharmacopoeia	<ul style="list-style-type: none"> On <i>Settings</i> > <i>System Setup</i> tab > <i>Local Settings</i> area, configure values in <i>Pharmacopoeia</i> area.
Setup Result Preferences	<ul style="list-style-type: none"> On <i>Settings</i> > <i>System Setup</i> tab, specify preferences for displaying and printing results.
Upgrade Firmware	<ul style="list-style-type: none"> On <i>Settings</i> > <i>Instrument Settings</i> > <i>Analyzer Settings</i> tab, upgrade firmware.



Role Names	Role Abilities
View Audit Trail	<ul style="list-style-type: none"> View data on <i>DataGuard > Audit Trail</i> tab.
View Data	<ul style="list-style-type: none"> On <i>Data</i> screen, view data.
View Errors	<ul style="list-style-type: none"> View data on <i>Settings > Errors</i> tab.
View Favorites	<ul style="list-style-type: none"> On <i>Protocols</i> screen, view data on <i>System Protocols</i> and <i>User Defined Methods</i> tabs.
View System Information	<ul style="list-style-type: none"> On <i>Settings > System Setup</i> tab > <i>Local Settings</i> area > <i>Pharmacopoeia</i> area, display <i>Stage 1 Conductivity Table</i>.

Configuring Login Settings

Use the *Settings* tab to define requirements for DataGuard User IDs and passwords, including the length of time that users are inactive before DataGuard times them out and the number of times that users can login incorrectly before their accounts are suspended.

To configure login settings

Use the following step-by-step instructions to configure DataGuard User ID and password requirements.

1. On the *DataGuard*  screen, select the *Settings* tab.

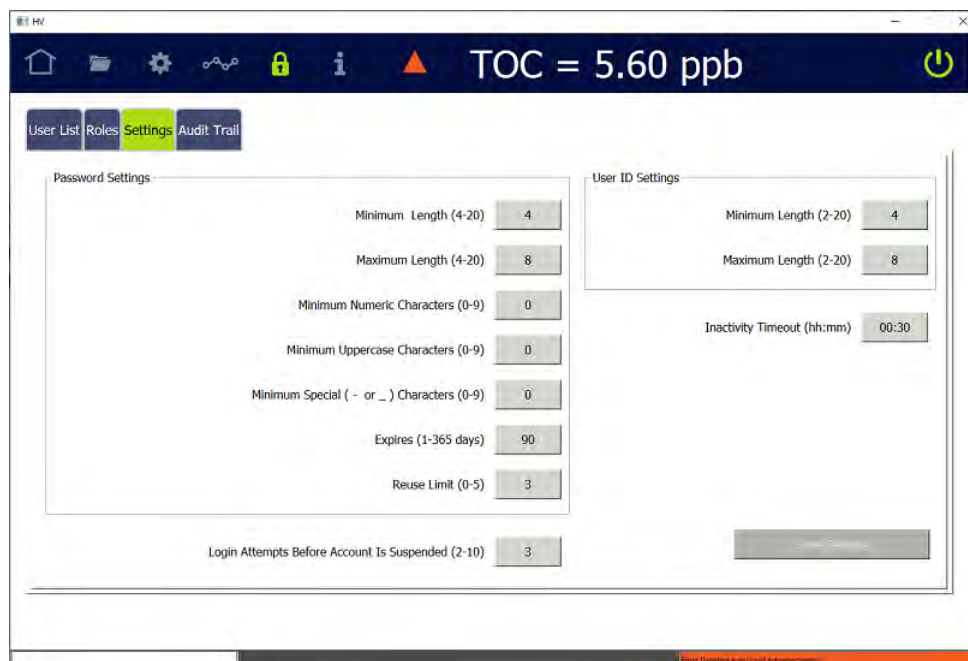

2. In the *User ID Settings* area, enter a value for the minimum and maximum length of a User ID (between 2 and 20 characters). The default values are 4 and 8.
3. In the *Password Settings* area, complete the following:
 - **Minimum Length (4-20)** — Press inside the field and use the numeric keypad to enter a value for the minimum length of a password (between 4 and 20 characters). The default value is 4.
 - **Maximum Length (4-20)** — Press inside the field and use the keypad to enter a value for the maximum length of a password (between 4 and 20 characters). The default value is 8.
 - **Minimum Numeric Characters (0-9)** — Press inside the field and use the keypad to enter a value for the minimum number of numeric characters in a password (between 0 and 9). The default value is 0.
 - **Minimum Uppercase Characters (0-9)** — Press inside the field and use the keypad to enter a value for the minimum number of upper case characters in a password (between 0 and 9). The default value is 0.
 - **Minimum Special (- or _) Characters (0-9)** — Press inside the field and use the keypad to enter a value for the minimum number of special characters in a password (between 0 and 9). The default value is 0. The keypad for entering passwords includes 24 special characters.
 - **Expires (1-365 days)** — Press inside the field and use the keypad to enter a value for the number of days (between 1 and 365) until a changed password expires. The default value is 90.
 - **Reuse Limit (0-5)** — Press inside the field and use the keypad to enter a value to specify the number of recent passwords that cannot be reused (between 0 and 5). The default value is 3. If a user creates password A, and this value is set to three, then the user cannot make password A their current password again until they have changed it three times.
4. Complete the value fields for each of the following:
 - **Inactivity Timeout (hh:mm)** — Press inside the field and use the numeric keypad to enter a value in minutes (between 1 and 600, that is, 10 hours) to specify how long users can remain inactive before DataPro2 automatically signs them out of the system. The value is displayed as hours and minutes. The default value is 00:30, that is, 30 minutes. For example, to set the Inactivity Timeout to one hour and 30 minutes, enter 90 minutes.
 - **Login Attempts Before Account Is Suspended (2-10)** — Press inside the field and use the numeric keypad to enter the number of incorrect password entries allowed (between 2 and 10) before DataPro2 automatically sets the User ID status to *Inactive*. The default value is 3.



- Click **SAVE SETTINGS** to save the settings.

Changing User Passwords

This section contains information for changing your DataGuard password:

- [“To change your DataGuard password if your Access Level has the *Change Password* role” on page 207](#)
- [“To change your DataGuard password if your Access Level has the *Edit User* role” on page 208](#)

To change your DataGuard password if your Access Level has the *Change Password* role

Follow these steps to change your current and active password if your Access Level has the *Change Password* role but does not have the *Edit User* role. If your Access Level has the *Edit User* role, see [“To change your DataGuard password if your Access Level has the *Edit User* role” on page 208](#).

- On the *DataGuard*  screen, select the *User List* tab.

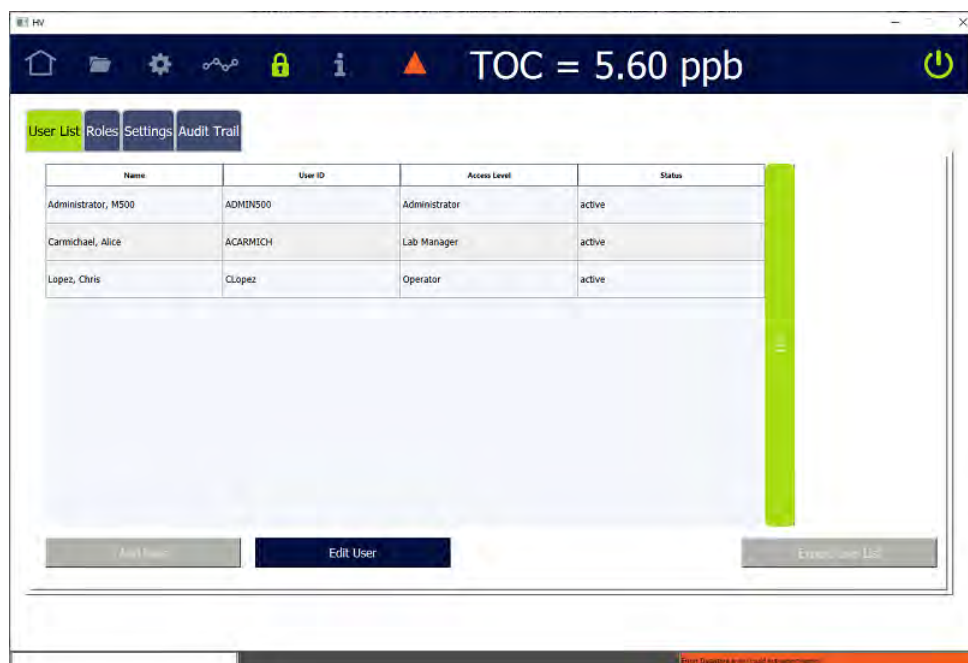

- Select the line with your User ID and press **EDIT USER**. The *Change Password* dialog box appears.

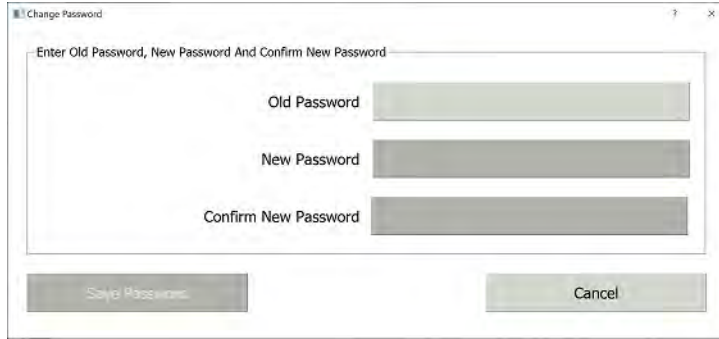

3. Press inside the field and use the numeric keypad to enter your current password for the *Old Password*.
4. In the next two fields, press inside each field and use the keypad to enter your new password.
5. Press **SAVE PASSWORD**.

To change your DataGuard password if your Access Level has the *Edit User* role

Follow these steps to change your current and active password if your Access Level (for example, *Administrator*) has the the *Edit User* role.

1. On the *DataGuard*  screen, select the *User List* tab.
2. Select the line with your User ID and press **EDIT USER**. The *User Settings* dialog box appears.



The screenshot shows a 'User Settings' window with an 'Add User' form. The form includes the following fields and values:

Field	Value
User ID	ACARMICH
Last Name	Carmichael
First Name	Alice
Middle Initial	
Access Level	Operator
Status	active
Password	*****
Confirm Password	*****

At the bottom of the form, there are two buttons: 'Save User' (highlighted in green) and 'Cancel' (greyed out).

3. Press inside the field and use the numeric keypad to enter your new password in both the *Password* and *Confirm Password* fields.
4. Press **SAVE USER**.

Replacing a Forgotten Password

This section contains information for retrieving forgotten or deactivated passwords.

To obtain a new password

If you exceed the number of unsuccessful sign-in attempts allowed by the system (as set by the Administrator; see [“To configure login settings” on page 205](#)) or you forget your password, contact Technical Support or your local service provider.

1. Locate the Security Key number (shown on the *Enter User ID and Password* dialog box), and provide it to Technical Support or your local service provider, who will supply a “Password of the Day.”
2. Sign into DataGuard using this temporary password. DataGuard will then require you to change your password. If needed, refer to [“To change your DataGuard password if your Access Level has the Change Password role” on page 207](#).

Working with Audit Trails

The DataGuard feature maintains an audit trail showing the history of activities performed on the Analyzer by each User ID. Each audit trail entry details what action was performed, when the action was performed, and the name of the user who performed the action. When appropriate, the old and new values of the action also are stored.

The audit trail output format is shown in Table 8:

Table 8: Audit Trail Output Format

Field #	Field Contents	Format/Notes	Example
1	Date and Time	dd MMM yyyy hh:mm:ss	23 SEP 2020 12:03:01
2	Action		Change user settings
3	User Name		M500 Administrator
4	Old Value		Access Level Change: Administrator
5	New Value		CLopez: Operator

To view and filter audit trail records

Use this procedure to view all audit trail data and to narrow down the data to a date range, a specific user, or specific action, or a combination of the three.

1. On the *DataGuard*  screen, select the *Audit Trail* tab.

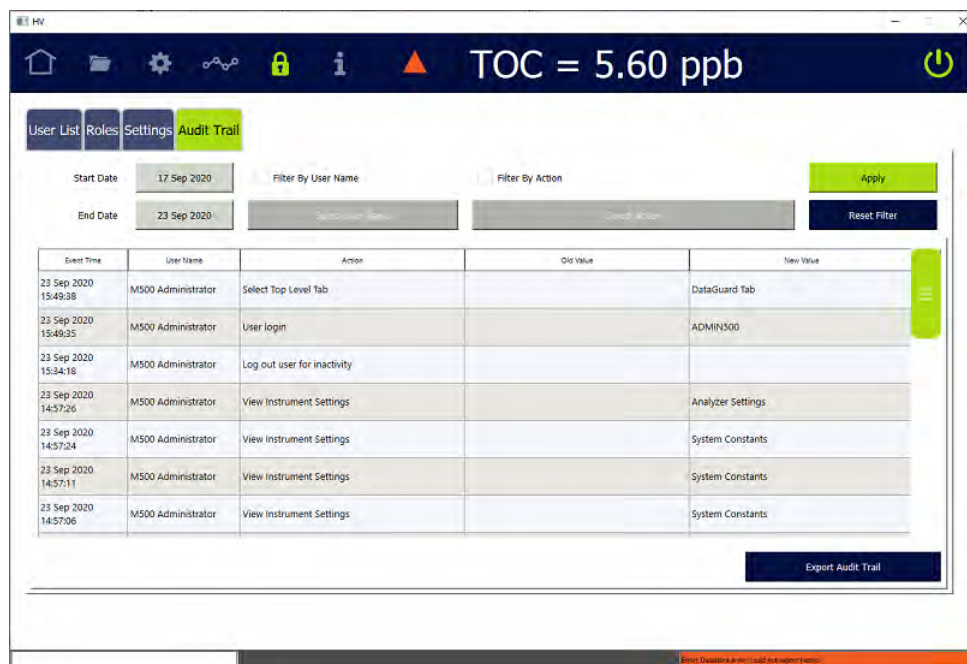



2. To filter the data shown on the Audit Trail tab, select a *Start Date* and *End Date* for the records displayed.
3. If you want to see records for only one user, select the *Filter By User Name* check box and press **SELECT USER NAME**. The *Select User* dialog box appears.



4. Select the line with the name of the user and press **SELECT USER**.
5. If you want to see records for only one action, select the *Filter By Action* check box and press **SELECT ACTION**. The *Select Audit Trail Action* dialog box appears.

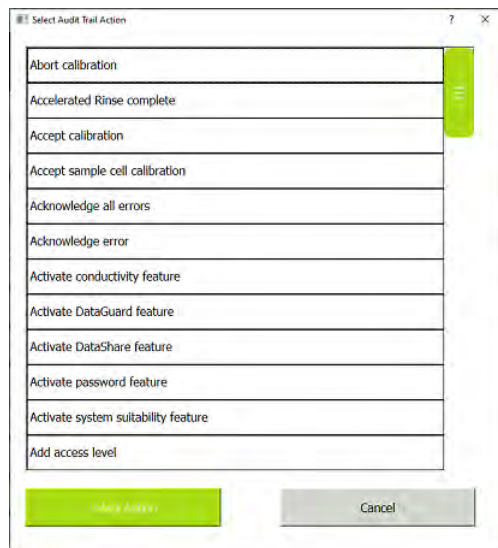

6. Select the line with the action and press **SELECT ACTION**.
7. Press **APPLY**.

- To reset the display to show all actions for all users for all dates, press **RESET FILTER**.

Logging Out of DataGuard

When users have finished their activities on the Analyzer, logging out prevents a second user from accessing the system under the first user's account. This practice helps preserve the integrity of the audit trail. Logging out also minimizes the risk of unauthorized access by other personnel.

To log out of DataGuard

- Go to the *Home*  screen.

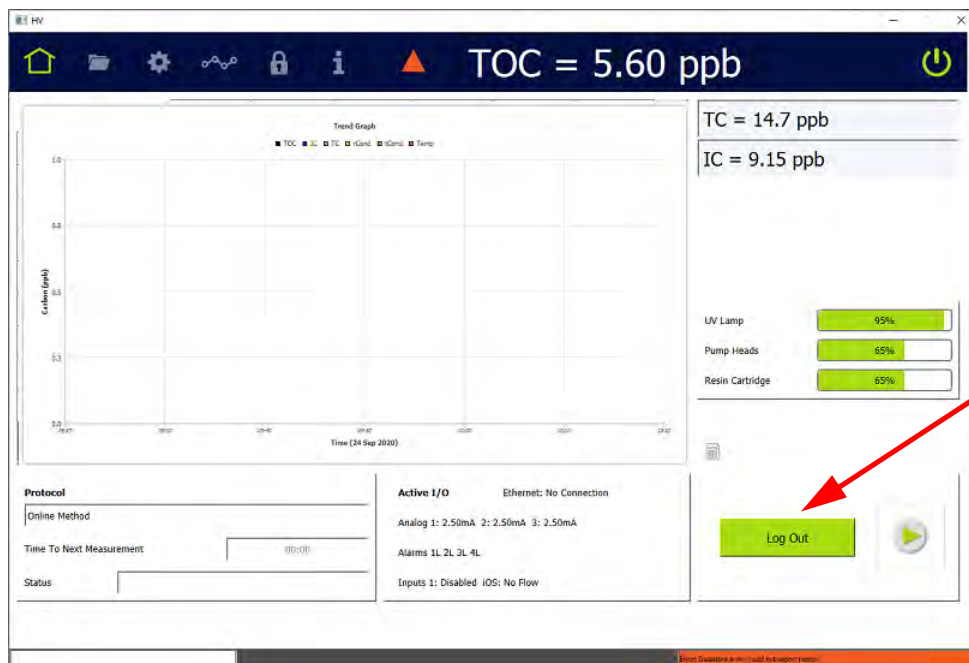

- Press the **LOG OUT** button. The Analyzer outlines the *Home*  screen icon in light blue and replaces the **LOG OUT** button with a **LOGIN** button.

6

CALIBRATION AND SYSTEM PROTOCOLS

.....

OVERVIEW

The Sievers M500 TOC Analyzer is calibrated at the factory and should require recalibration only once per year. When replacing items that affect analysis, such as the UV lamp or pump heads, perform a verification of the calibration. Only re-calibrate if verification indicates that a new calibration is necessary.

Calibration and other system protocols use Sievers Standards in vials sampled via the Analyzer's Integrated Online Sampling (iOS) System. The Analyzer facilitates the calibration and verification process by handling the necessary calculations internally. The user will have the opportunity to accept or reject the calibration during the procedure.

Calibrate the Sievers M500 TOC Analyzer using one of two methods: single-point calibration at 1.5 ppm; or multi-point calibration at 500 ppb, 1.0 ppm, and 1.5 ppm. SUEZ recommends single-point calibration for most applications. Multi-point calibration is available as an alternative procedure for customers. A Single-Point Calibration requires approximately one hour to complete and the Multi-Point Calibration requires approximately two hours.

If the Analyzer has a standard iOS System (one vial port), insert the appropriate standard into the iOS with each Analyzer prompt. If Analyzer is configured with a Super iOS System (four vial ports), insert all standards required for most system protocols into the iOS at one time (However, when running a Multi-Point calibration, it will be necessary to switch vials once during the procedure.



NOTE: Only a single-point calibration or a multi-point calibration needs to be performed. Do not perform both types of calibration—only the most recent calibration will be stored.

If the Analyzer is equipped with a sample inlet block, install an iOS to calibrate and verify the Analyzer.

PERFORMING PHARMACOPOEIA TESTS



The Sievers M500 TOC Analyzer is designed to comply with various Pharmacopeia testing. Additional Method Specificity and Method Robustness protocols, compliant with ICH Q2(R1), are also available as optional protocols from SUEZ Customer Care or your local service provider.

The Analyzer firmware performs all functions necessary to meet the following international Pharmacopeia specifications: China Pharmacopeia, European Pharmacopeia, Indian Pharmacopeia, Japanese Pharmacopeia, and the United States Pharmacopeia. The response efficiency and response limit are automatically calculated. For more detailed information regarding compliance with these pharmacopoeias, please refer to ["Working with Pharmacopoeia Monographs" on page 143](#).

PROGRAMMING THE TOC AUTOZERO

The TOC Autozero protocol determines the TOC offset, which is the difference between the IC and TC measurements with the UV lamp off. It also determines the background conductivity curves for each channel.

The Analyzer can be set to automatically perform a TOC Autozero at a specific interval. The TOC Autozero is recommended only if the TOC concentration in the sample stream is 50 ppb or less.

1. If the Analyzer is taking measurements, press **STOP ANALYSIS** .
2. On the *System Protocols*  screen, select the *Calibration* tab.
3. Select *TOC Autozero*, then press **SETUP**.

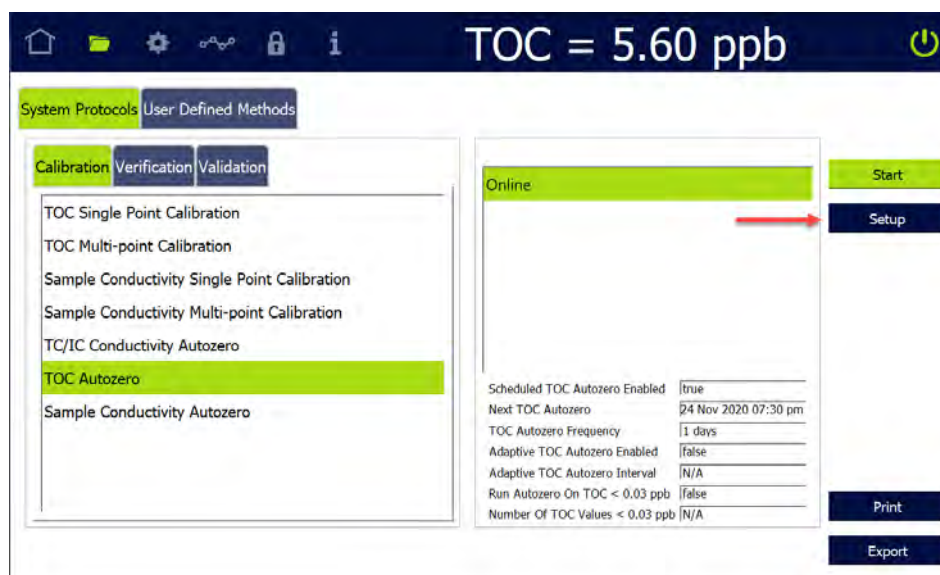



4. The *Setup TOC Autozero* dialog box appears.

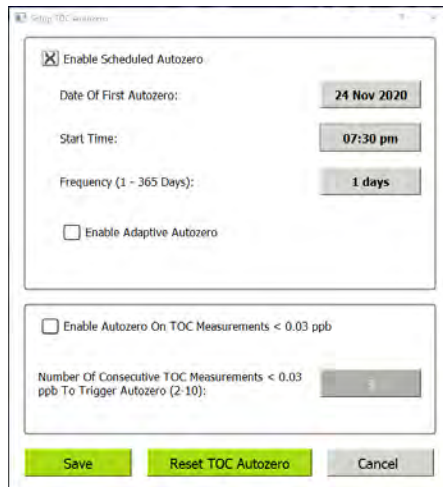



5. If it is not already enabled, select the *Enable Scheduled Autozero* check box.
6. Use the buttons next to *Date of First Autozero*, *Start Time*, and *Frequency* to specify the timing of the automatic TOC Autozero.
7. To enable autozero on TOC measurements < 0.03 ppb, select the appropriate check box. Doing so will allow you to select the number of consecutive TOC measurements < 0.03 ppb that will trigger the autozero process.
8. Press **SAVE** to apply the changes. There is also an option to *Reset TOC Autozero*.

The *Enable Adaptive Autozero* check box enables the Analyzer to change the frequency of the scheduled TOC autozero based on the magnitude of the change of the TOC offset. As the Analyzer rinses down and the TOC offset stabilizes, the autozero frequency increases or decreases automatically, without user intervention.

PROGRAMMING THE TC/IC CONDUCTIVITY AUTOZERO

The TC/IC Conductivity Autozero protocol determines the IC and TC cell offsets. The Analyzer can be set to automatically perform a TC/IC Conductivity Autozero at a specific interval, or the user can run the protocol manually.

1. If the Analyzer is taking measurements, press **STOP ANALYSIS** .
2. On the *System Protocols*  screen, select the *Calibration* tab.
3. Select *TC/IC Conductivity Autozero*, then press **SETUP**.

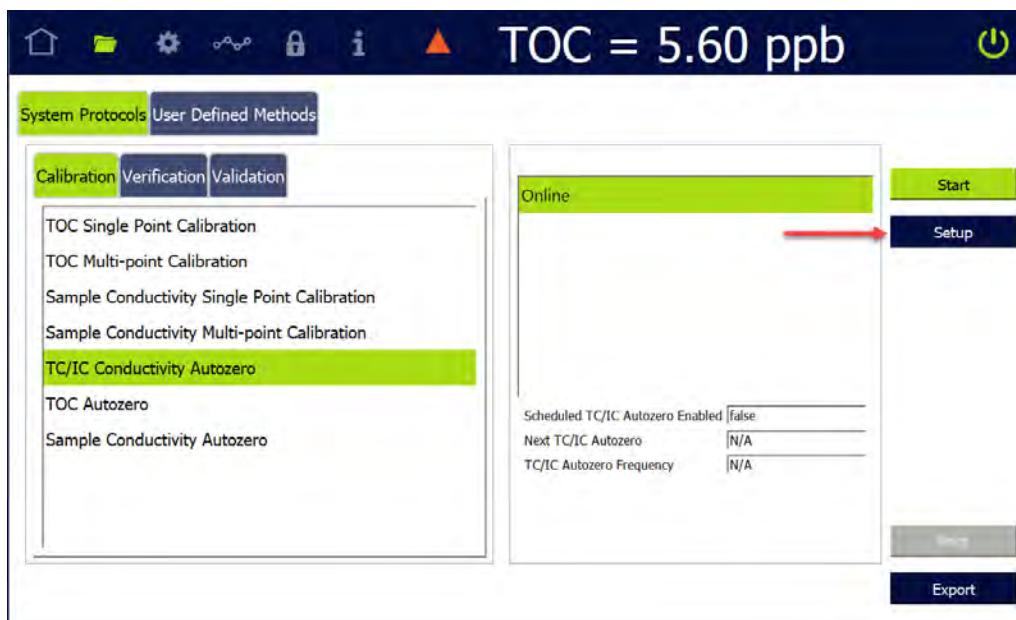

4. The *Setup TC/IC Conductivity Autozero* dialog box appears.

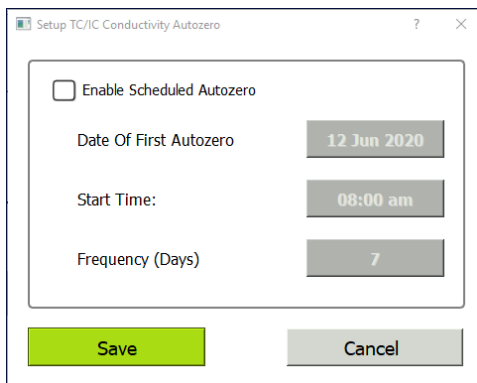

5. If it is not already enabled, select the *Enable Scheduled Autozero* check box.



6. Use the buttons next to *Date of First Autozero*, *Start Time*, and *Frequency* to specify the timing of the automatic TC/IC Conductivity Autozero.
7. Press **SAVE** to apply the changes.

REQUIRED CALIBRATION SUPPLIES

The number of standards required for the calibration procedure depends on whether running a single-point or multi-point calibration. Standards vials are inserted into the iOS System as prompted by the Analyzer's on-screen instructions.

A single-point calibration should require approximately one hour to complete, and multi-point calibration should require approximately two hours to complete.



NOTE: For all calibration and verification procedures use only Sievers standards purchased from SUEZ.

To purchase standards, contact Customer Care or your local service provider.

Standards sets for calibration and verification can be purchased individually, or as vial sets for use with a Super iOS System. All standards are provided in 40-mL and 30-mL vials. Standards sets for validation can be purchased individually, or as a combined Validation Set.

Standards used in each of the system protocols are shown in Table 9 through Table 21. Standards concentrations are shown in ppm and ppb. Note that 1 ppm = 1 mg C/L, and 1 ppb = 1 µg C/L. For configurations without conductivity measurement, standards sets without conductivity standards are available.



NOTE: Conductivity protocols and standards are for Analyzers that have the conductivity option activated.

An optional Flush Set of four blank standards is also available from SUEZ. This Flush Set is optional, but recommended for running before, after, or before and after protocols using the Super iOS.

TABLE 9: STANDARDS REQUIRED FOR TOC SINGLE-POINT CALIBRATION

Calibration Blank
Reagent Water Blank - Rw
1.5 ppm TOC (as KHP)

Note: 1 ppm = 1 mg C/L, 1 ppb = 1 µg C/L

TABLE 10: STANDARDS REQUIRED FOR TOC MULTI-POINT CALIBRATION

Calibration Blank
Reagent Water Blank - Rw (2 vials)
1.5 ppm TOC (as KHP)
1 ppm TOC (as KHP)
500 ppb TOC (as KHP)

Note: 1 ppm = 1 mg C/L, 1 ppb = 1 µg C/L

TABLE 11: STANDARDS REQUIRED FOR SAMPLE CONDUCTIVITY SINGLE-POINT CALIBRATION

100 µS/cm Cond (as KCl)
Empty 40 mL Vial (used for alignment only)

Note: 1 ppm = 1 mg C/L, 1 ppb = 1 µg C/L

TABLE 12: STANDARDS REQUIRED FOR SAMPLE CONDUCTIVITY MULTI-POINT CALIBRATION

Calibration Blank
Reagent Water Blank - Rw (2 vials)
1.5 ppm TOC (as KHP)
1 ppm TOC (as KHP)
500 ppb TOC (as KHP)

Note: 1 ppm = 1 mg C/L, 1 ppb = 1 µg C/L



TABLE 13: STANDARDS REQUIRED FOR SYSTEM SUITABILITY VERIFICATION

Reagent Water Blank - Rw
500 ppb TOC (as sucrose) - Rs
500 ppb TOC (as benzoquinone) - Rss

Note: 1 ppm = 1 mg C/L, 1 ppb = 1 µg C/L

TABLE 14: STANDARDS REQUIRED FOR ACCURACY & PRECISION VERIFICATION

Reagent Water Blank - Rw
500 ppb TOC

Note: 1 ppm = 1 mg C/L, 1 ppb = 1 µg C/L

TABLE 15: STANDARDS REQUIRED FOR CELL CALIBRATION VERIFICATION

Rinse - Reagent Water
25 µS/cm Cond (as KCl)

Note: 1 ppm = 1 mg C/L, 1 ppb = 1 µg C/L

TABLE 16: STANDARDS REQUIRED FOR SAMPLE CONDUCTIVITY VERIFICATION

Rinse - Reagent Water
25 µS/cm Cond (as KCl)

Note: 1 ppm = 1 mg C/L, 1 ppb = 1 µg C/L

TABLE 17: STANDARDS REQUIRED FOR TOC LINEARITY VERIFICATION

Reagent Water Blank - Rw
250 ppb TOC (as KHP)
500 ppb TOC (as KHP)
750 ppb TOC (as KHP)
1 ppm TOC (as KHP) (if 5-point option selected)
1.25 ppm TOC (as KHP)(if 5-point option selected)

Note: 1 ppm = 1 mg C/L, 1 ppb = 1 µg C/L

TABLE 18: STANDARDS REQUIRED FOR ROBUSTNESS VALIDATION

Reagent Water Blank - Rw
500 ppb Rs (as USP Sucrose)
500 ppb Rss (as Benzoquinone)

Note: 1 ppm = 1 mg C/L, 1 ppb = 1 µg C/L

TABLE 19: STANDARDS REQUIRED FOR SPECIFICITY VALIDATION

Reagent Water Blank - Rw
500 ppb MeOH
500 ppb Nic
500 ppb TOC (as KHP)

Note: 1 ppm = 1 mg C/L, 1 ppb = 1 µg C/L



TABLE 20: STANDARDS REQUIRED FOR SDBS SUITABILITY

Reagent Water Blank - Rw
500 ppb TOC (as Sodium Dodecylbenzenesulfonate) - SDBS
Empty Glass Vial (for alignment)
<i>Note: To perform the JP Conductivity Protocol, also prepare a conductivity standard onsite of 1 vial of 29.4 $\mu\text{S/cm}$ (0.2 mM) Potassium Chloride (KCl). This standard is NOT available from SUEZ.</i>

Note: 1 ppm = 1 mg C/L, 1 ppb = 1 μg C/L

TABLE 21: STANDARDS REQUIRED FOR SAMPLE CONDUCTIVITY LINEARITY VALIDATION

5 $\mu\text{S/cm}$ Cond (as KCl)
10 $\mu\text{S/cm}$ Cond (as KCl)
25 $\mu\text{S/cm}$ Cond (as KCl)
50 $\mu\text{S/cm}$ Cond (as KCl)
100 $\mu\text{S/cm}$ Cond (as KCl)

Note: 1 ppm = 1 mg C/L, 1 ppb = 1 μg C/L

Warning	
	Consult the MSDS that accompanies each standards set to identify proper disposal techniques.

Caution	
Standards for the Sievers M500 TOC Analyzer are acidified. If preparing your own standards and using glass vials, ensure to acidify the standards to a pH of 3, or the system protocols will yield poor results.	

CALIBRATION PREPARATIONS

Saving System Settings

Prior to performing any calibration procedure or system protocol, save the current system settings, in the event they need to be re-loaded. (Consider also printing the settings for future reference.)

To save the system settings

1. On the *Instrument Settings*  screen > *Instrument Settings* tab, select *Analyzer Settings*.
2. Press **EXPORT SETTINGS**.

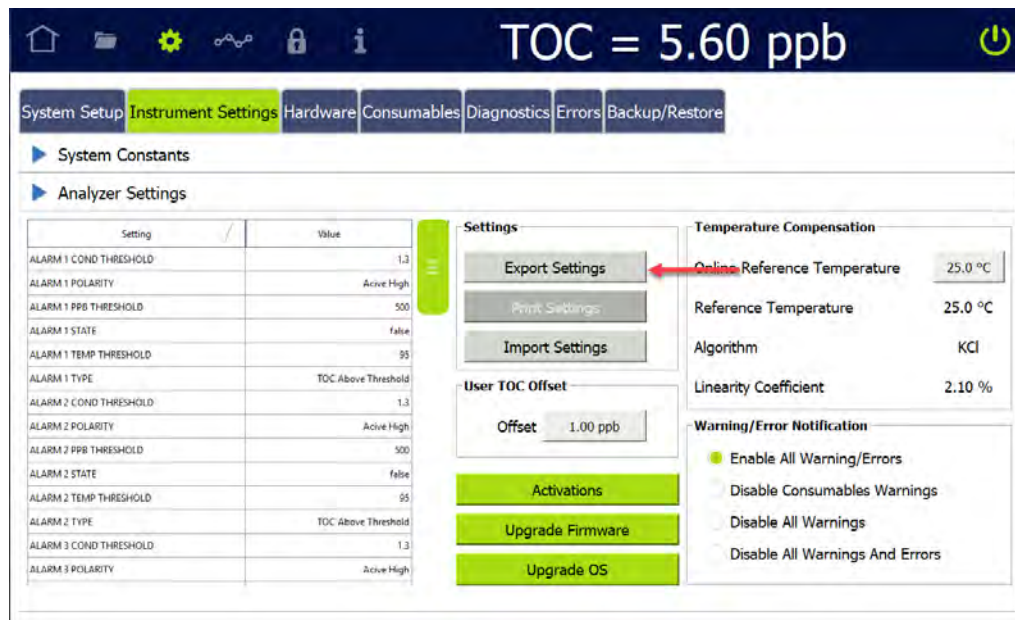

3. The next screen shows file type, file name, and path options for the system settings export file.
4. Select the Export File Type from the list of options on the right side of the screen.
5. The export file path chosen during system setup is automatically selected.



NOTE: To change this path, go to the *Settings*  screen > *System Setup* tab, and select *Export Preferences*.

- The filename appears as the date/time stamp of the export. You can change this filename by selecting the File Name field and using the on-screen keyboard to type a file name.
- Press **SAVE** to export the system settings.



To back up the database and settings

- On the *Instrument Settings* screen > *Backup/Restore* tab, in the *Manual Backup/Restore* section, select either *USB* or *Network* as the file destination, then click the *Path* button.

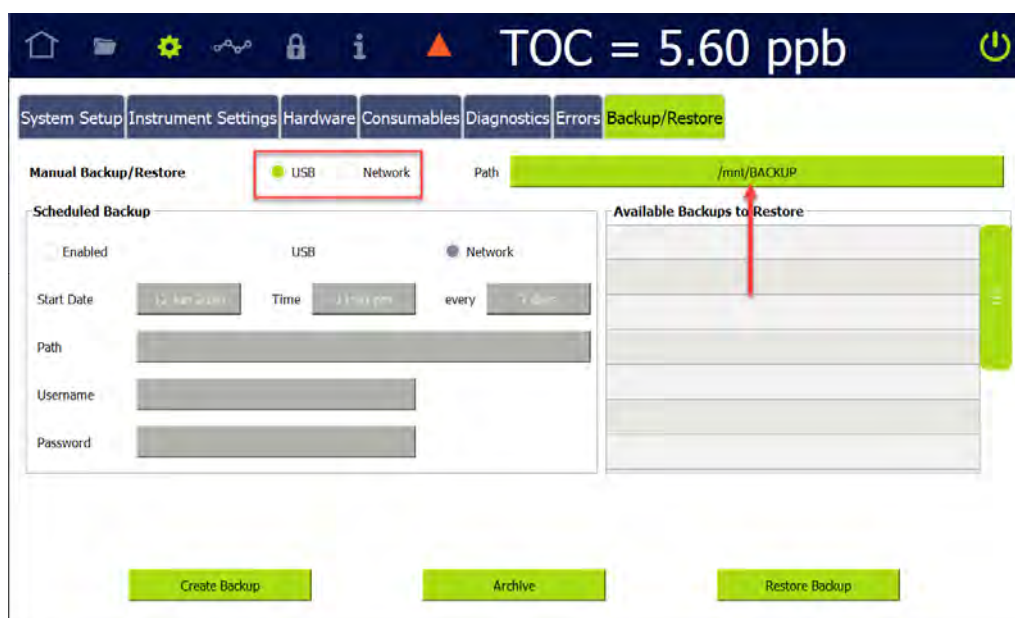

Chapter 6 CALIBRATION AND SYSTEM PROTOCOLS

- For USB—Insert a USB memory device into the USB port, select a path or create a new folder, and press **SAVE**.

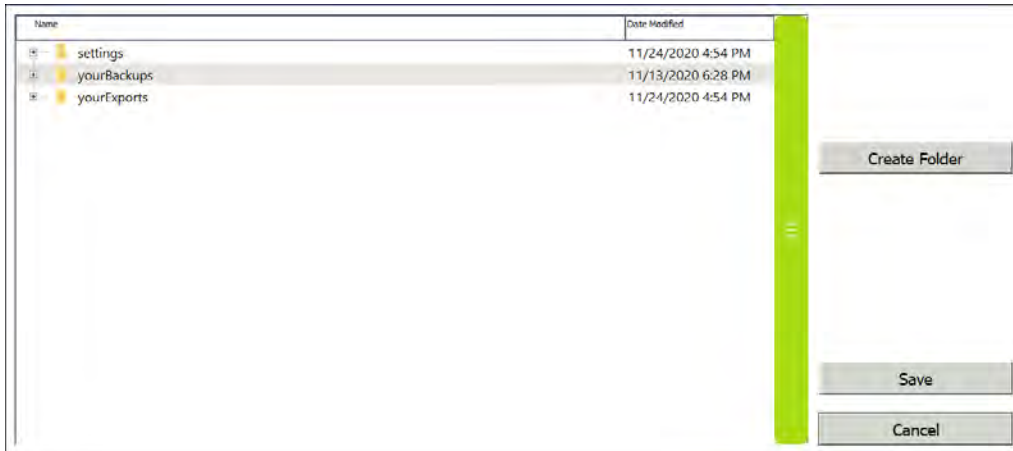

- For Network—Press **NETWORK CREDENTIALS** to specify the network path, username and password, then press **OK**.

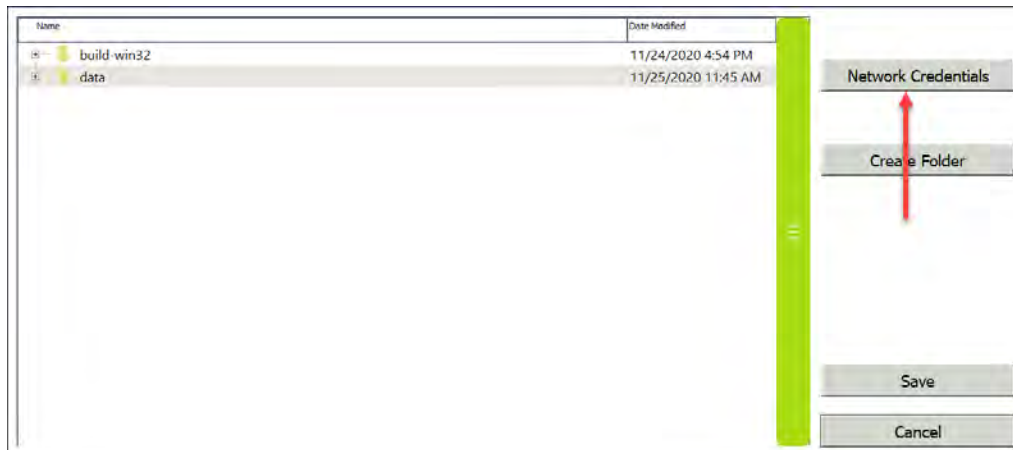

Please specify the network path, as well as the username and password for accessing the network folder and click OK when ready.

Network Path

Username

Password

- Select a path or create a new folder, and press **SAVE**.



2. Press **CREATE BACKUP**.

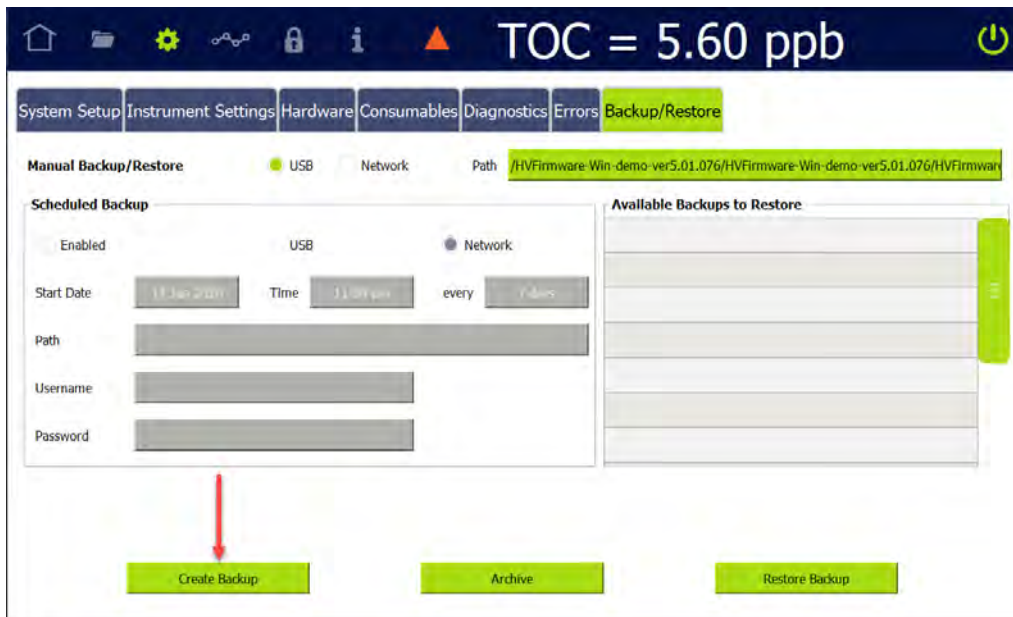

Chapter 6 CALIBRATION AND SYSTEM PROTOCOLS

The backup file appears in the *Available Backups to Restore* section. To restore the backup file, select it from the list and press **RESTORE BACKUP**.

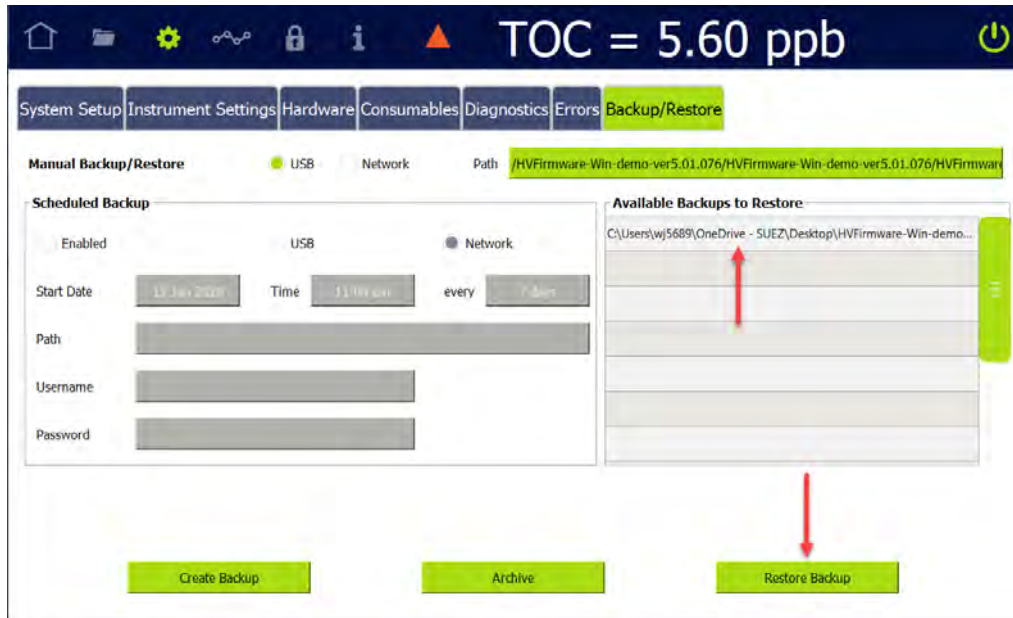

Performing Annual Maintenance Tasks

Before calibrating the Analyzer, perform annual maintenance tasks as appropriate, such as replacing the sample pump heads, UV lamp, and resin cartridge. In particular, if the calibration coincides with the Analyzer's annual maintenance, first replace the resin cartridge before proceeding; for more information, see ["Replacing the Resin Cartridge" on page 415](#).

Handling Standards

Because of the prevalence of both conductivity contaminants and organic carbon contaminants, sample preparation and control is extremely delicate. Special handling of the standard solutions is required.

Store standards at approximately 5 °C (±4 °), away from light, in a box or solid-door refrigerator. Warm standards to ambient temperature prior to starting analysis. Avoid touching the top of the vials to protect against introducing foreign particles, TOC, and conductivity.

Super iOS Drain/Rinse

If running protocols on a Sievers M500 TOC Analyzer with the Super iOS System, the user is prompted to drain the Super iOS and select a rinse option at the start of each protocol:

1. If using a Super iOS System:
 - 1.1 A *Drain Super iOS* dialog box appears.

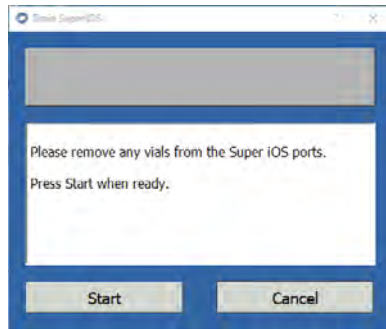

- 1.2 Remove any vials from the Super iOS ports and press **START**.

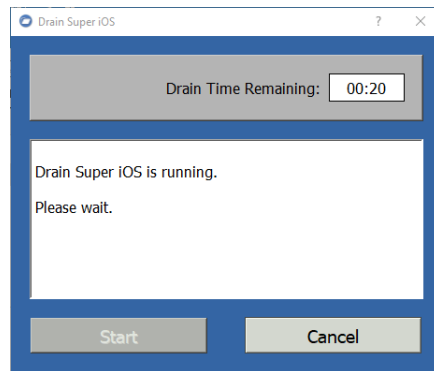

- 1.3 When the drain process is complete, press **CLOSE** to continue. A *Rinse Super iOS* dialog box appears.

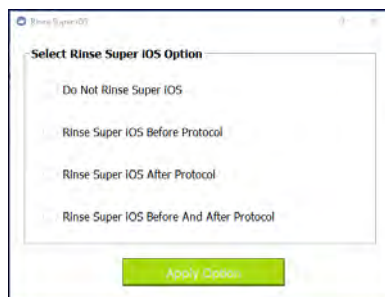



- 1.4 Choose one of the rinse options:
 - Do Not Rinse Super iOS
 - Rinse Super iOS Before Protocol
 - Rinse Super iOS After Protocol
 - Rinse Super iOS Before And After Protocol
- 1.5 Press **APPLY OPTION**. Depending on the option selected, the following dialog box will appear at the chosen time(s):



- 1.5.1 Insert a rinse vial into each of the four Super iOS ports and press **START**.
- 1.5.2 When the rinse process is complete, press **CLOSE**.

Using Individual Vials in the Super iOS

Super iOS cartridge sets are available for all calibrations and system protocols. For Analyzers equipped with the Super iOS, cartridges enable automatic temperature compensation and conductivity adjustments for those protocols that require them, and eliminate the need to manually change vials.

If you choose to use individual vials rather than cartridges for the Super iOS, follow the steps shown in the example below:

1. When prompted to insert a vial set (cartridge)...

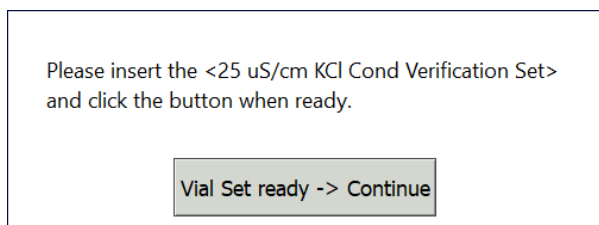

...do not insert a vial yet. Press **VIAL SET READY-> CONTINUE**. On the dialog box that appears, press **CONTINUE** to confirm that you want to continue the protocol with individual vials.

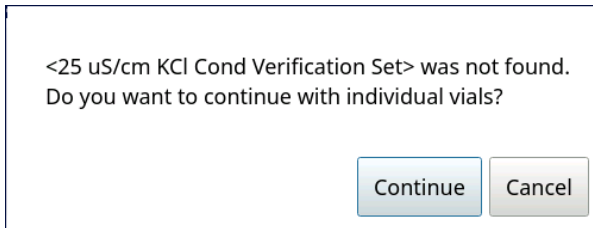

2. For protocols that require it, you will be prompted to specify conductivity standard values or temperature compensation (Super iOS cartridges are pre-programmed with this information).
3. A dialog box appears with instructions for loading individual vials into the Super iOS ports. Be sure to load the vials into the ports specified:

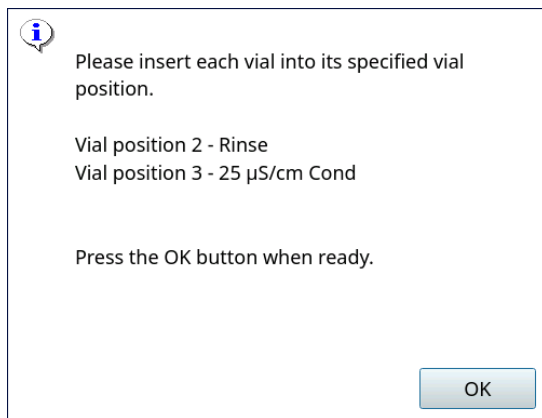

4. Press **OK** to continue, then follow the rest of the steps as listed in each protocol.

TOC Single Point Calibration

1.0 INTRODUCTION

Perform the following TOC Single Point Calibration Protocol to calibrate a Sievers M500 TOC Analyzer for TOC.

2.0 SCOPE

This procedure applies to the Sievers M500 TOC Analyzer.



NOTE: Choose **either** a single-point or multi-point calibration for validation purposes (not both). For multi-point instructions, See "TOC Multi-point Calibration Protocol" on page 236.

3.0 MATERIALS



NOTE: Use **only** Sievers standards purchased from SUEZ.

- 3.1 Sievers M500 TOC Analyzer
- 3.2 TOC Single Point Calibration Worksheet
- 3.3 Calibration Set A (TOC Only)
 - 3.3.1 One vial — Cal Blank 1
 - 3.3.2 One vial — Rw Blank
 - 3.3.3 One vial — 1.5 ppm TOC
- 3.4 (**OPTIONAL WHEN USING THE SUPER IOS**) SUEZ recommends the Flush Set for rinsing before, after, **or** before and after running the protocol.

4.0 DEFINITIONS

- 4.1 NONE

5.0 PROCEDURE

- 5.1 (**OPTIONAL**) If DataGuard is enabled, log in to the Analyzer with a User ID and the appropriate password.
- 5.2 If the Analyzer is taking measurements, press **STOP ANALYSIS** .
- 5.3 Export the current system settings for future reference or reloading by following the steps in ["To save the system settings" on page 222](#).

Chapter 6 CALIBRATION AND SYSTEM PROTOCOLS

- 5.4 Back up the database and settings by following the steps in ["To back up the database and settings" on page 223](#).
- 5.5 On the *System Protocols*  screen, select the *Calibration* tab.

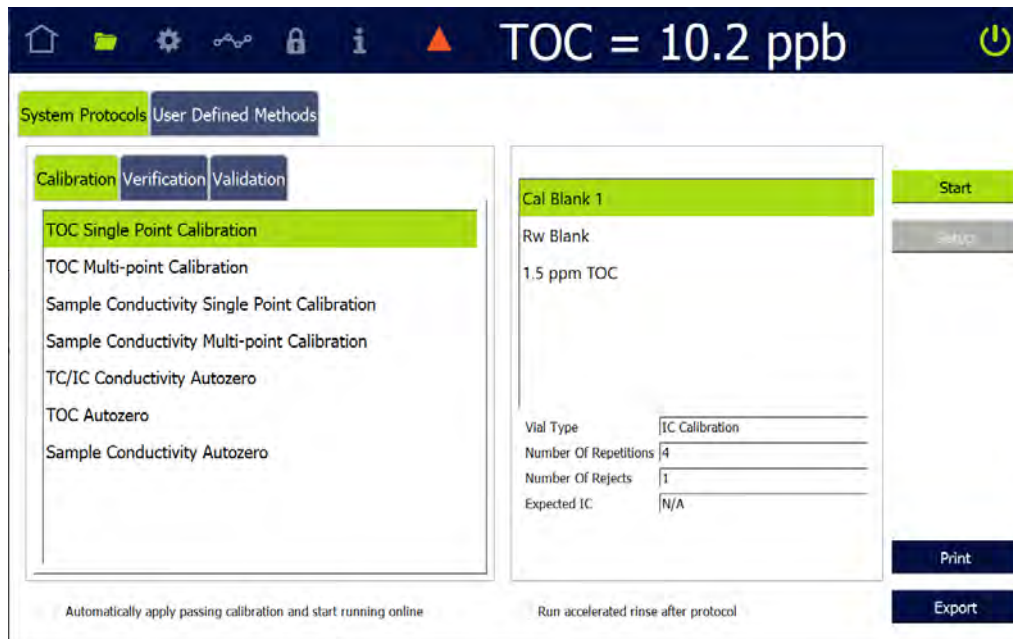

- 5.6 Select **TOC Single Point Calibration**, then press **START**.
- 5.7 If using a standard iOS System, go to step [5.9](#).
- 5.8 If using a Super iOS System, follow the prompts for the drain and rinse options (described in ["Super iOS Drain/Rinse" on page 228](#)).
- 5.8.1 A *Please insert...* dialog box appears.

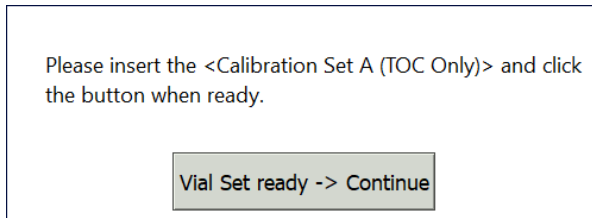



5.8.2 Insert **Calibration Set A (TOC Only)** and press **VIAL SET READY-> CONTINUE**. The Analyzer begins analysis of the vial set.

If using individual vials, **do not** insert them. Press **VIAL SET READY-> CONTINUE**. See ["Using Individual Vials in the Super iOS" on page 229](#) for more information.

- Port 1 = **Cal Blank 1**
- Port 2 = **Rw Blank**
- Port 3 = **1.5 ppm TOC**

5.8.3 When analysis of the vial set is complete, remove it from the Super iOS. If a *Rinse After...* option was selected, follow the on-screen prompts for rinsing

5.8.4 Go to step [5.10](#).

5.9 If using a standard iOS System:

5.9.1 A *Please insert Cal Blank 1...* dialog box appears.

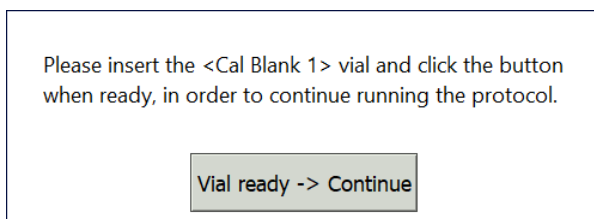

5.9.2 Open the door to the iOS System and wait 30 seconds for water to drain.

5.9.3 Insert the **Cal Blank 1** vial into the iOS System and press **VIAL READY-> CONTINUE**. The Analyzer begins analysis of the vial.

5.9.4 When analysis of the **Cal Blank 1** vial is complete, a *Please insert Rw Blank...* dialog box appears.

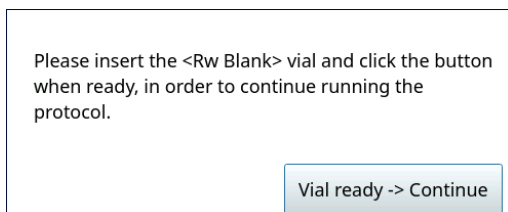

5.9.5 Remove the **Cal Blank 1** vial, then insert the **Rw Blank** vial into the iOS System and press **VIAL READY-> CONTINUE**. The Analyzer begins analysis of the vial.

- 5.9.6 When analysis of the **Rw Blank** vial is complete, a *Please insert the 1.5 ppm TOC...* dialog box appears.

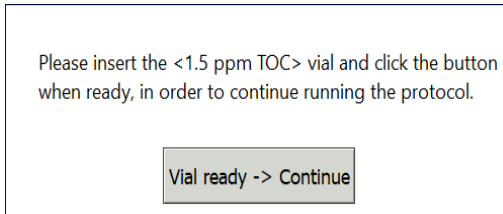

- 5.9.7 Remove the **Rw Blank** vial, then insert the **1.5 ppm TOC** vial into the iOS System and press **VIAL READY-> CONTINUE**. The Analyzer begins analysis of the vial.
- 5.9.8 When analysis of the vial is complete, remove it from the iOS and press **VIAL REMOVED -> CONTINUE**.



- 5.10 The *TOC Single Point Calibration: Protocol Complete* screen appears with the *Summary* tab active and multiple tabs available for reviewing, as follows:



	Value	Limit	Result
Cal Blank1 IC RSD	0.22 %	≤ 3.00 %	Passed
Cal Blank1 TC RSD	0.00 %	≤ 3.00 %	Passed
1.500 ppm TOC RSD	2.50 %	≤ 3.00 %	Passed
Change in IC Slope	-20.0 %	± 20.0 %	Passed
Change in TC Slope	-20.0 %	± 20.0 %	Passed

- Vial 1–3 — Select these tabs to view analysis details for each standard, as needed.
- Summary — Select this tab to view the summary of analysis, including *passed* or *failed* results. It also contains the **APPLY**, **REJECT**, **PRINT**, and **EXPORT** buttons.

5.11 Referencing the *Summary* tab, record the results data on the *TOC Single Point Calibration Worksheet*.

5.12 Do one of the following:

5.12.1 If the calibration *passed*, press **APPLY** to accept the calibration. A confirmation message appears. Press **APPLY CALIBRATION**, then **CLOSE**.

Are you sure you want to apply this calibration to your analyzer ?

Go back to Summary Apply calibration

5.12.2 If the calibration *failed*, leave the screen as is and contact Technical Support or your local service provider. Before calling, e-mail the backup and system settings files (created in advance of running calibration protocols). After analysis of the data, you may be advised to accept the results or to pursue additional troubleshooting steps.

5.13 To print or export the results, press the corresponding button.

TOC Multi-point Calibration Protocol

1.0 INTRODUCTION

Perform the following TOC Multi-point Calibration Protocol to calibrate a Sievers M500 TOC Analyzer for TOC.

2.0 SCOPE

This procedure applies to the Sievers M500 TOC Analyzer.



NOTE: Choose *either* a single-point or multi-point calibration for validation purposes (not both). For single-point instructions, See “TOC Single Point Calibration” on page 231.

3.0 MATERIALS



NOTE: Use *only* Sievers standards purchased from SUEZ.

- 3.1 Sievers M500 TOC Analyzer
- 3.2 *TOC Multi-point Calibration Worksheet*
- 3.3 **Calibration Set A (TOC Only)**
 - 3.3.1 One vial — **Cal Blank 1**
 - 3.3.2 Two vials — **Rw Blank**
 - 3.3.3 One vial — **1.5 ppm TOC**
- 3.4 **Calibration Set B**
 - 3.4.1 One vial — **Rw Blank**
 - 3.4.2 One vial — **1 ppm TOC**
 - 3.4.3 One vial — **500 ppb TOC**
- 3.5 **(OPTIONAL WHEN USING THE SUPER IOS)** SUEZ recommends the **Flush Set** for rinsing before, after, **or** before and after running the protocol.



4.0 DEFINITIONS

4.1 NONE

5.0 PROCEDURE

5.1 (**OPTIONAL**) If DataGuard is enabled, log in to the Analyzer with a User ID and the appropriate password.

5.2 If the Analyzer is taking measurements, press **STOP ANALYSIS** .

5.3 Export the current system settings for future reference or reloading by following the steps in ["To save the system settings" on page 222](#).

5.4 Back up the database and settings by following the steps in ["To back up the database and settings" on page 223](#).

5.5 On the *System Protocols*  screen, select the *Calibration* tab.

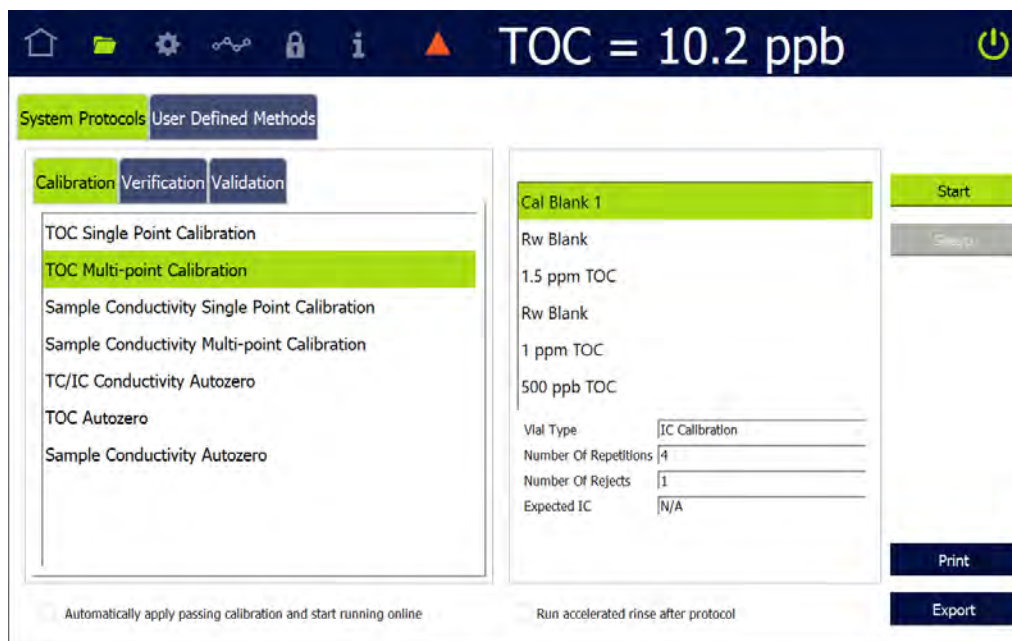

5.6 Select **TOC Multi-point Calibration**, then press **START**.

5.7 If using a standard iOS System, go to step [5.9](#).

5.8 If using a Super iOS System, follow the prompts for the drain and rinse options (described in ["Super iOS Drain/Rinse" on page 228](#)).

5.8.1 A *Please insert...* dialog box appears.

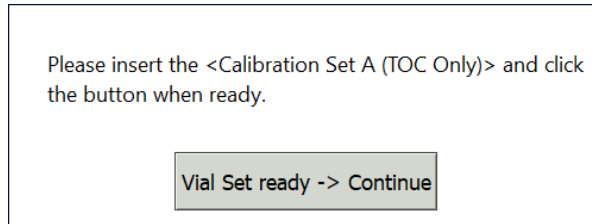

5.8.2 Insert **Calibration Set A (TOC Only)** and press **VIAL SET READY-> CONTINUE**. The Analyzer begins analysis of the vial set.

If using individual vials, **do not** insert them. Press **VIAL SET READY-> CONTINUE**. See ["Using Individual Vials in the Super iOS" on page 229](#) for more information.

- Port 1 = **Cal Blank 1**
- Port 2 = **Rw Blank**
- Port 3 = **1.5 ppm TOC**

5.8.3 When analysis of **Calibration Set A (TOC Only)** is complete, a *Please insert Calibration Set B...* dialog box appears.

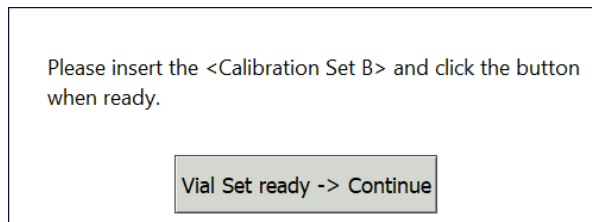

5.8.4 Remove **Calibration Set A (TOC Only)**, then insert **Calibration Set B** and press **VIAL SET READY-> CONTINUE**. The Analyzer begins analysis of the vial set.

- Port 2 = **Rw Blank**
- Port 3 = **1 ppm TOC**
- Port 4 = **500 ppb TOC**

5.8.5 When analysis of the vial set is complete, remove it from the Super iOS. If a *Rinse After...* option was selected, follow the on-screen prompts for rinsing.

5.8.6 Go to step [5.10](#).

5.9 If using a standard iOS System:



5.9.1 A *Please insert...* dialog box appears.

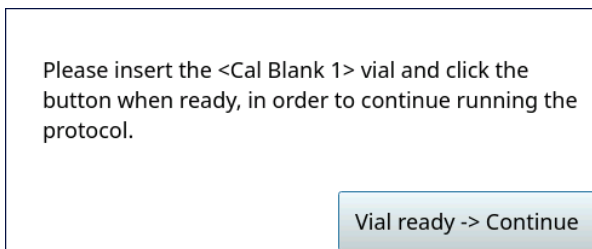

5.9.2 Open the door to the iOS System and wait 30 seconds for water to drain.

5.9.3 Insert the **Cal Blank 1** vial into the iOS System and press **VIAL READY-> CONTINUE**. The Analyzer begins analysis of the vial.

5.9.4 When analysis of the **Cal Blank 1** vial is complete, a *Please insert Rw Blank...* dialog box appears.

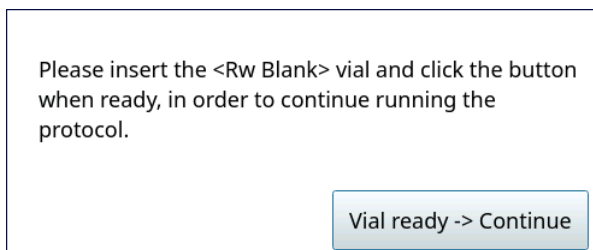

5.9.5 Remove the **Cal Blank 1** vial, then insert the **Rw Blank** vial into the iOS System and press **VIAL READY-> CONTINUE**. The Analyzer begins analysis of the vial.

5.9.6 When analysis of the **Rw Blank** vial is complete, a *Please insert the 1.5 ppm TOC...* dialog box appears.

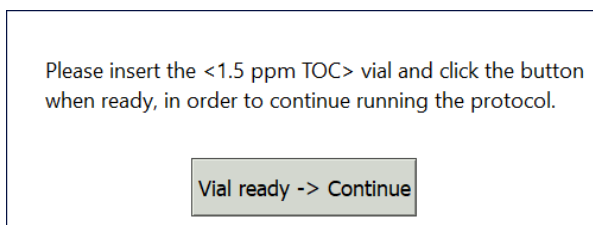

5.9.7 Remove the **Rw Blank** vial, then insert the **1.5 ppm TOC** vial into the iOS System and press **VIAL READY-> CONTINUE**. The Analyzer begins analysis of the vial.

- 5.9.8 When analysis of the 1.5 ppm TOC vial is complete, a *Please insert the Rw Blank...* dialog box appears.

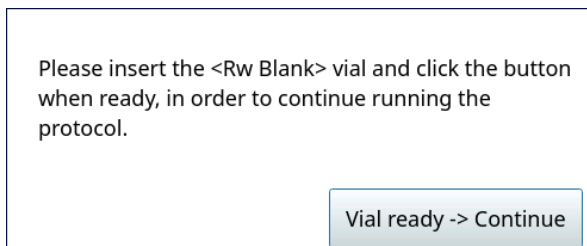

- 5.9.9 Remove the 1.5 ppm TOC vial, then insert the Rw Blank vial into the iOS System and press **VIAL READY-> CONTINUE**. The Analyzer begins analysis of the vial.

- 5.9.10 When analysis of the Rw Blank vial is complete, a *Please insert the 1 ppm TOC...* dialog box appears.

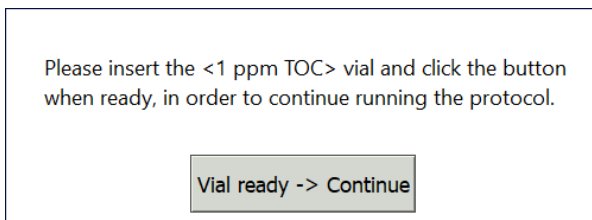

- 5.9.11 Remove the Rw Blank vial, then insert the 1 ppm TOC vial into the iOS System and press **VIAL READY-> CONTINUE**. The Analyzer begins analysis of the vial.

- 5.9.12 When analysis of the 1 ppm TOC vial is complete, a *Please insert the 500 ppb TOC...* dialog box appears.

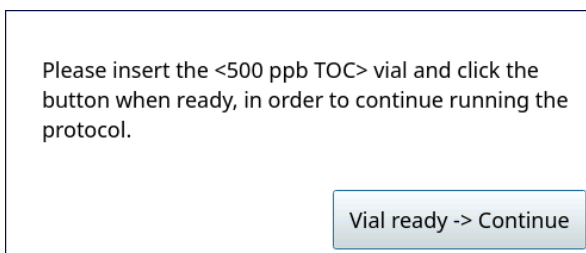

- 5.9.13 Remove the 1 ppm TOC vial, then insert the 500 ppb TOC vial into the iOS System and press **VIAL READY-> CONTINUE**. The Analyzer begins analysis of the vial.



5.9.14 When analysis of the vial is complete, remove it from the iOS and press **VIAL REMOVED -> CONTINUE**.

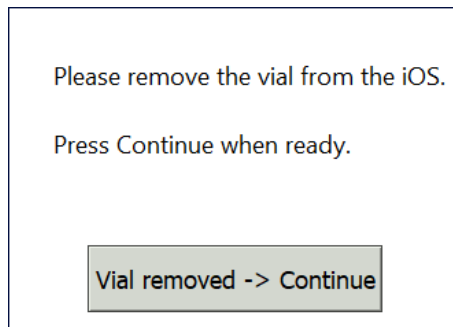

5.10 The *TOC Multi-point Calibration: Protocol Complete* screen appears with the *Summary* tab active and multiple tabs available for reviewing, as follows:

	Value	Limit	Result
Cal Blank 1 IC RSD	0.77 %	≤ 3.00 %	Passed
Cal Blank 1 TC RSD	0.58 %	≤ 3.00 %	Passed
1.5 ppm TOC RSD	0.25 %	≤ 3.00 %	Passed
1 ppm TOC RSD	0.46 %	≤ 3.00 %	Passed
500 ppb TOC RSD	0.28 %	≤ 3.00 %	Passed
Change in IC Slope	9.43 %	± 20.0 %	Passed
Change in TC Slope	11.8 %	± 20.0 %	Passed
TOC Regression Slope	1.002	N/A	N/A
R-squared	0.9998	≥ 0.988	Passed

- Vial 1–6 — Select these tabs to view analysis details for each standard, as needed.
- Summary — Select this tab to view the summary of analysis, including *passed* or *failed* results. It also contains the **APPLY**, **REJECT**, **PRINT**, and **EXPORT** buttons.

5.11 Referencing the *Summary* tab, record the results data on the *TOC Multi-point Calibration Worksheet*.

5.12 Do one of the following:

5.12.1 If the calibration *passed*, press **APPLY** to accept the calibration. A confirmation message appears. Press **APPLY CALIBRATION**, then **CLOSE**.

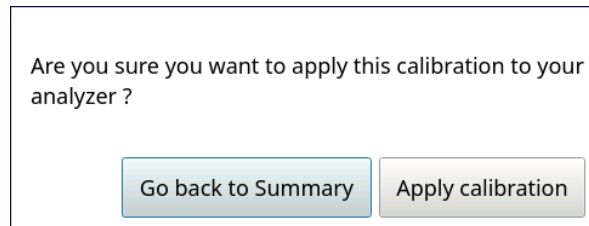

5.12.2 If the calibration *failed*, leave the screen as is and contact Technical Support or your local service provider. Before calling, e-mail the backup and system settings files (created in advance of running calibration protocols). After analysis of the data, you may be advised to accept the results or to pursue additional troubleshooting steps.

5.13 To print or export the results, press the corresponding button.



Sample Conductivity Single Point Calibration Protocol

1.0 INTRODUCTION

Perform the following Sample Conductivity Single Point Calibration Protocol to calibrate the Sievers M500 TOC Analyzer for conductivity.

2.0 SCOPE

This procedure applies to the Sievers M500 TOC Analyzer.

3.0 MATERIALS



NOTE: Use *only* Sievers standards purchased from SUEZ.

- 3.1 Sievers M500 TOC Analyzer
- 3.2 *Sample Conductivity Single Point Calibration Worksheet*
- 3.3 100 $\mu\text{S}/\text{cm}$ KCl Conductivity Calibration
 - 3.3.1 One vial — 100 $\mu\text{S}/\text{cm}$ Cond
- 3.4 (**OPTIONAL WHEN USING THE SUPER IOS**) SUEZ recommends the **Flush Set** for rinsing before, after, **or** before and after running the protocol.

4.0 DEFINITIONS

- 4.1 NONE

5.0 PROCEDURE

- 5.1 (**OPTIONAL**) If DataGuard is enabled, log in to the Analyzer with a User ID and the appropriate password.
- 5.2 If the Analyzer is taking measurements, press **STOP ANALYSIS** .
- 5.3 Export the current system settings for future reference or reloading by following the steps in ["To save the system settings" on page 222](#).
- 5.4 Back up the database and settings by following the steps in ["To back up the database and settings" on page 223](#).

5.5 On the *System Protocols* screen, select the *Calibration* tab.

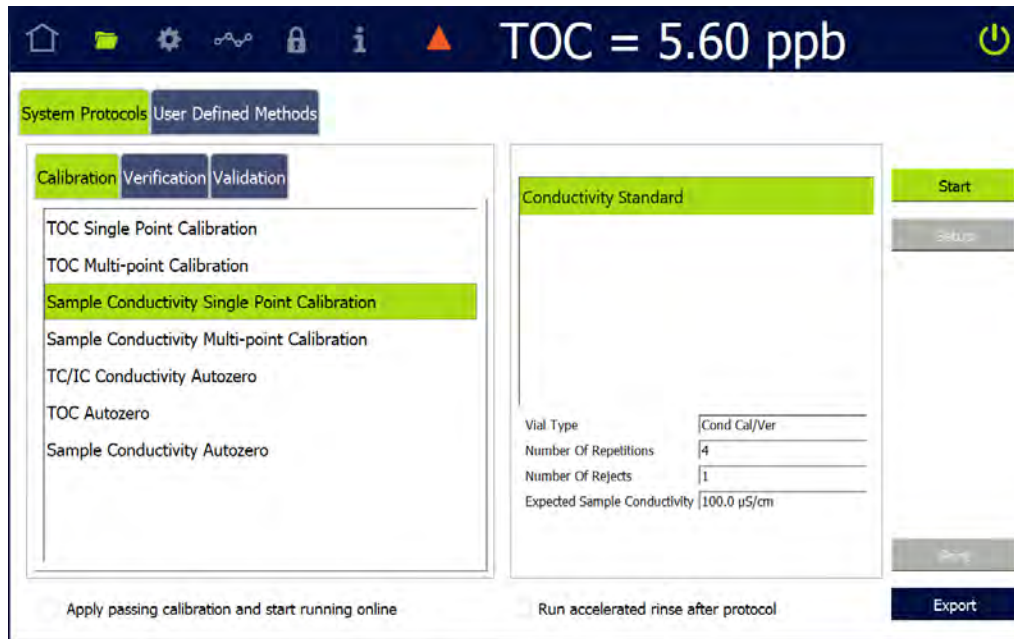

5.6 Select **Sample Conductivity Single Point Calibration**, then press **START**.

5.7 If using a standard iOS System, go to step [5.9](#).

5.8 If using a Super iOS System, follow the prompts for the drain and rinse options (described in ["Super iOS Drain/Rinse" on page 228](#)).

5.8.1 A *Please insert...* dialog box appears.

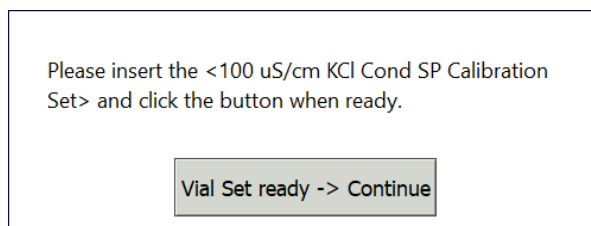

5.8.2 Insert the **100 µS/cm KCl Conductivity Calibration** and press **VIAL SET READY-> CONTINUE**, then go to step [5.8.7](#).

If using an individual vial, **do not** insert it. Press **VIAL SET READY-> CONTINUE**. See ["Using Individual Vials in the Super iOS" on page 229](#) for more information.

- Port 2 = **100 µS/cm Cond**



5.8.3 **(Individual vials only)** A *Conductivity Temperature Compensation* dialog box appears.

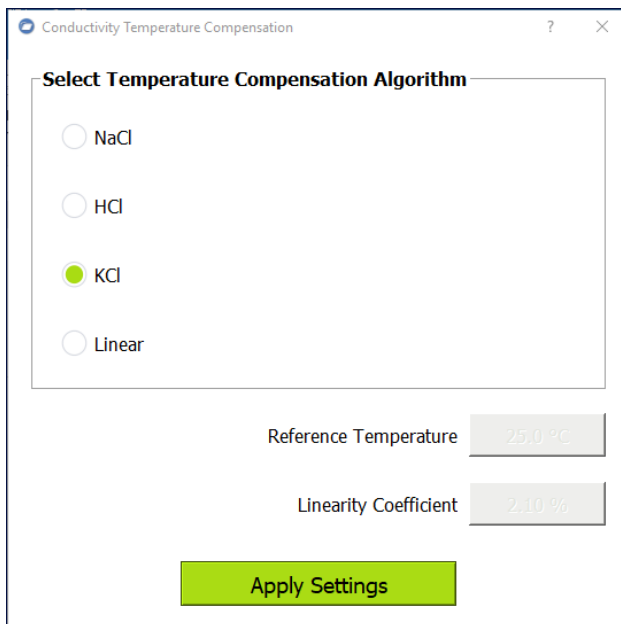

5.8.4 Select the temperature compensation algorithm from the list of options and press **APPLY SETTINGS** to continue.

5.8.5 A *Please specify the Conductivity Standard value...* dialog box appears.



NOTE: The conductivity standard value is user-definable within the specified range.

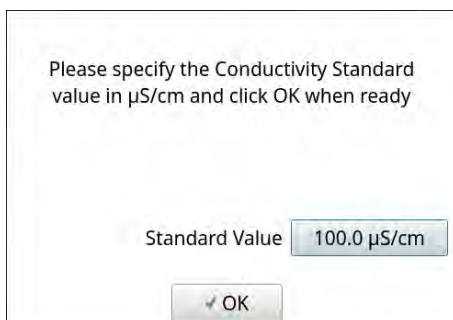

5.8.6 Leave the default value in the *Standard Value* field or press inside the field to use the numeric keypad to enter a new value and press **OK**.

5.8.7 When analysis of the vial set is complete, remove it from the Super iOS. If a *Rinse After...* option was selected, follow the on-screen prompts for rinsing.

5.8.8 Go to step [5.10](#).

5.9 If using a standard iOS System:

5.9.1 A Conductivity Temperature Compensation dialog box appears.

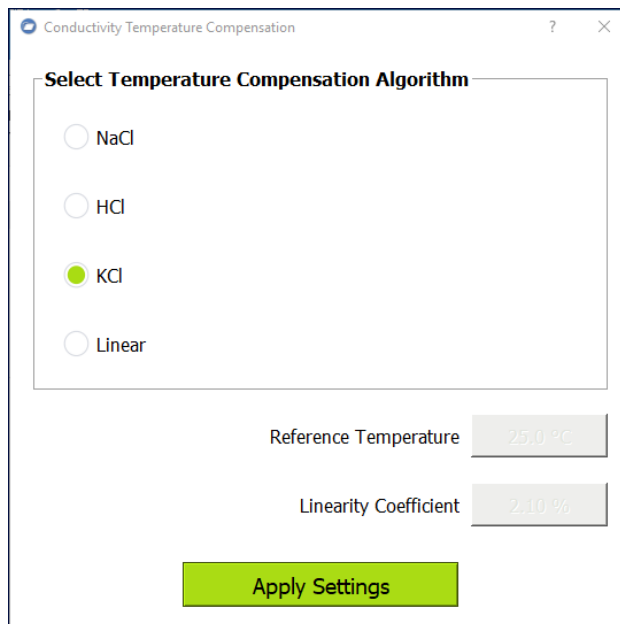

5.9.2 Select the temperature compensation algorithm from the list of options and press **APPLY SETTINGS** to continue.

5.9.3 A *Please specify the Conductivity Standard value...* dialog box appears.



NOTE: The conductivity standard value is user-definable within the specified range.

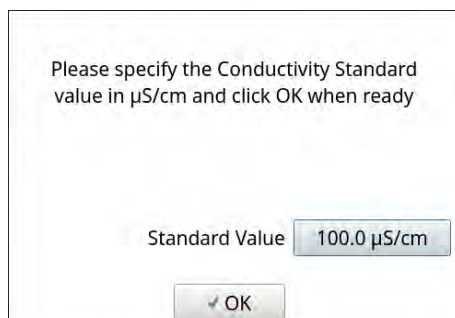

5.9.4 Leave the default value in the *Standard Value* field or press inside the field to use the numeric keypad to enter a new value and press **OK**.

5.9.5 A *Please insert the 100 μS/cm vial...* dialog box appears.

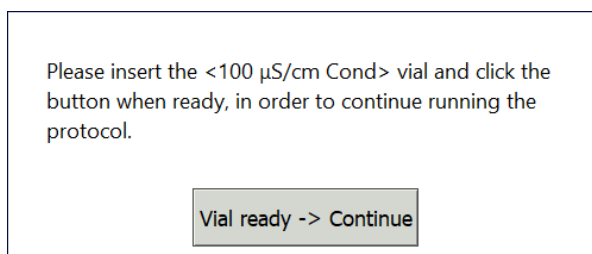



- 5.9.6 Open the door to the iOS System and wait 30 seconds for water to drain.
- 5.9.7 Insert the **100 μ S/cm Cond** (or other selected standard) vial into the iOS System and press **VIAL READY-> CONTINUE**. The Analyzer begins analysis of the vial.
- 5.9.8 When analysis of the vial is complete, remove it from the iOS and press **VIAL REMOVED -> CONTINUE**.

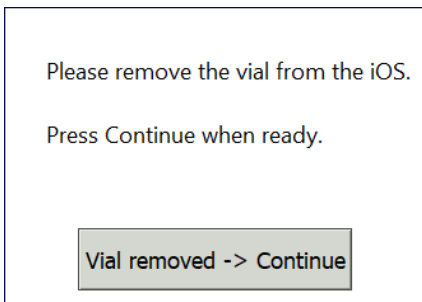

5.10 The *Sample Conductivity Single Point Calibration: Protocol Complete* screen appears with the *Summary* tab active and another tab available for reviewing:

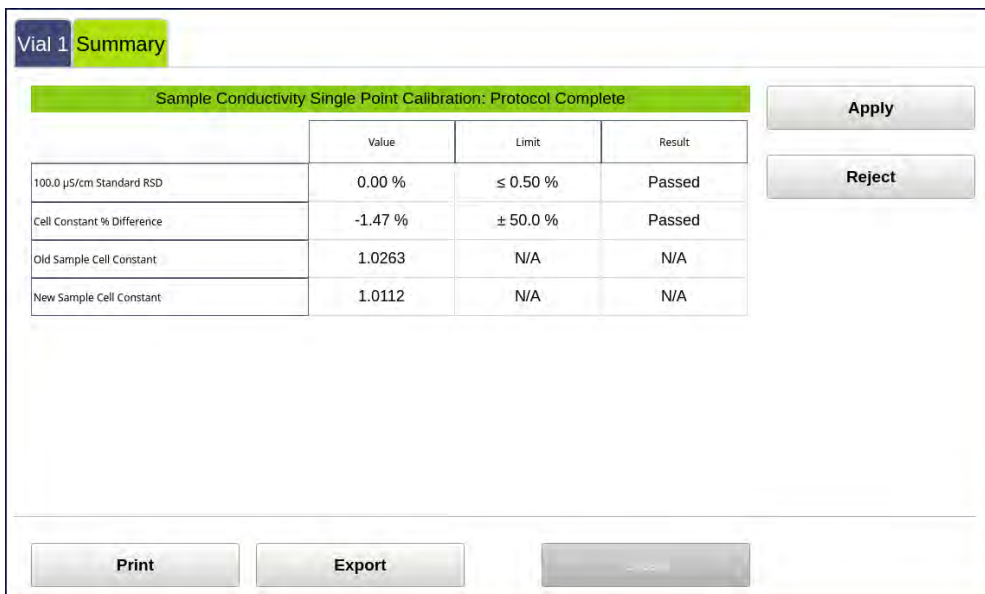

- Vial 1 — Select this tab to view analysis details for the **100 μ S/cm Cond** standard, as needed.
- Summary — Select this tab to view the summary of analysis, including *passed* or *failed* results. It also contains **APPLY**, **REJECT**, **PRINT**, **EXPORT**, and **CLOSE** buttons.

5.11 Referencing the *Summary* tab, record the results data on the *Sample Conductivity Single Point Calibration Worksheet*.

5.12 Do one of the following:

- 5.12.1 If the calibration *passed*, press **APPLY** to accept the calibration. A confirmation message appears. Press **APPLY CALIBRATION**, then **CLOSE**.

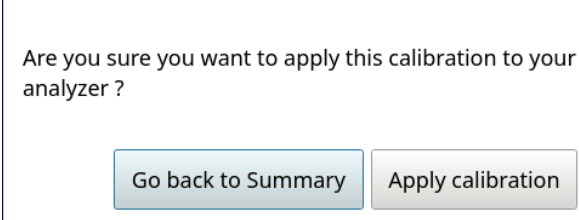

Are you sure you want to apply this calibration to your analyzer?

Go back to Summary Apply calibration

- 5.12.2 If the calibration *failed*, leave the screen as is and contact Technical Support or your local service provider. Before calling, e-mail the backup and system settings files (created in advance of running calibration protocols). After analysis of the data, you may be advised to accept the results or to pursue additional troubleshooting steps.
- 5.13 To print or export the results, press the corresponding button.



Sample Conductivity Multi-point Calibration Protocol

1.0 INTRODUCTION

Perform the following Sample Conductivity Multi-point Calibration Protocol to calibrate the Sievers M500 TOC Analyzer for conductivity.

2.0 SCOPE

This procedure applies to the Sievers M500 TOC Analyzer.

3.0 MATERIALS





NOTE: Use **only** Sievers standards purchased from SUEZ.

- 3.1 Sievers M500 TOC Analyzer
- 3.2 *Sample Conductivity Multi-point Calibration Worksheet*
- 3.3 **Conductivity Multi-point Calibration Set:**
 - 3.3.1 One vial — 100 $\mu\text{S/cm}$ Cond
 - 3.3.2 One vial — 146.9 $\mu\text{S/cm}$ Cond
 - 3.3.3 One vial — 718 $\mu\text{S/cm}$ Cond
 - 3.3.4 (**OPTIONAL WHEN USING THE SUPER IOS**) SUEZ recommends the **Flush Set** for rinsing before, after, **or** before and after running the protocol.

4.0 DEFINITIONS

- 4.1 NONE

5.0 PROCEDURE

- 5.1 (**OPTIONAL**) If DataGuard is enabled, log in to the Analyzer with a User ID and the appropriate password.
- 5.2 If the Analyzer is taking measurements, press **STOP ANALYSIS** .
- 5.3 Export the current system settings for future reference or reloading by following the steps in ["To save the system settings" on page 222](#).
- 5.4 Back up the database and settings by following the steps in ["To back up the database and settings" on page 223](#).
- 5.5 On the *System Protocols*  screen, select the *Calibration* tab.

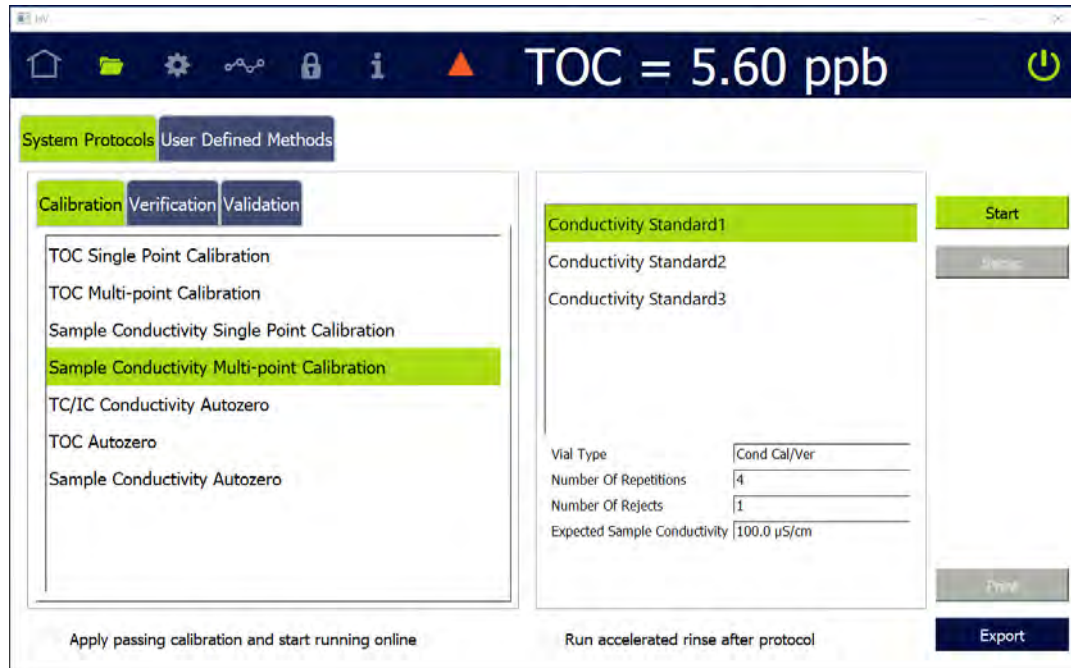

- 5.6 Select **Sample Conductivity Multi-point Calibration**, then press **START**.
- 5.7 If using a standard iOS System, go to step [5.9](#).
- 5.8 If using a Super iOS System, follow the prompts for the drain and rinse options (described in ["Super iOS Drain/Rinse" on page 228](#)).
- 5.8.1 A *Please insert...* dialog box appears.

Please insert the <Conductivity Multi-Point Calibration Set> and click the button when ready.

Vial Set ready -> Continue

- 5.8.2 Insert the **Conductivity Multi-Point Calibration Set** and press **VIAL SET READY-> CONTINUE**, then go to step [5.8.9](#).

If using individual vials, **do not** insert them. Press **VIAL SET READY-> CONTINUE**. See ["Using Individual Vials in the Super iOS" on page 229](#) for more information.

- Port 1 = 100 µS/cm Cond
- Port 2 = 146.9 µS/cm Cond
- Port 3 = 718 µS/cm Cond



5.8.3 **(Individual vials only)** A *Conductivity Temperature Compensation* dialog box appears.

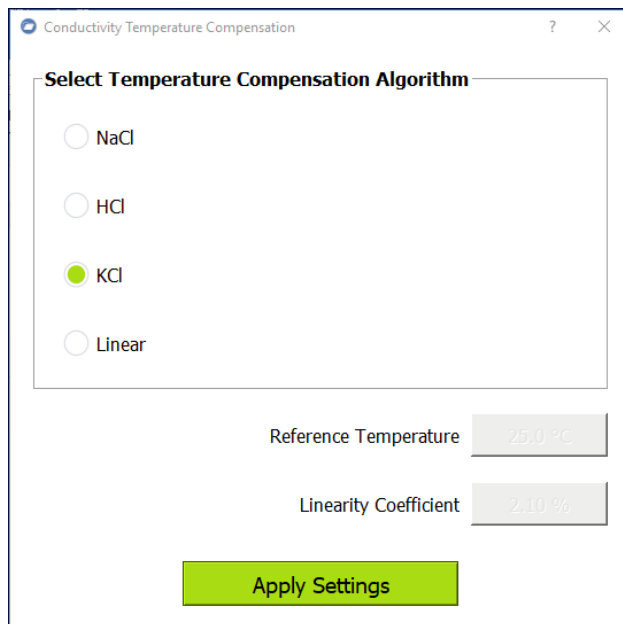

5.8.4 Select the temperature compensation algorithm from the list of options and press **APPLY SETTINGS** to continue.

5.8.5 A *Please specify the Conductivity Standard...* dialog box appears.



NOTE: The conductivity standard value is user-definable within the specified range.

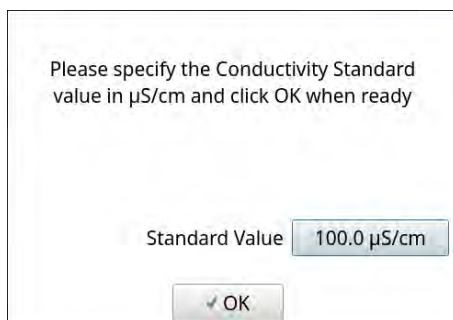

- 5.8.6 Leave the default value in the *Standard Value* field or press inside the field to use the numeric keypad to enter a new value and press **OK**.
A second *Please specify the Conductivity Standard...* dialog box appears.

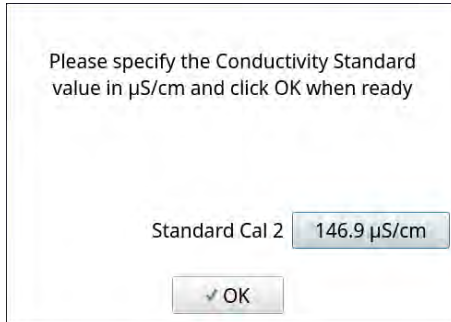

Please specify the Conductivity Standard value in $\mu\text{S}/\text{cm}$ and click OK when ready

Standard Cal 2 146.9 $\mu\text{S}/\text{cm}$

✓ OK

- 5.8.7 Leave the default value in the *Standard Value* field or press inside the field to use the numeric keypad to enter a new value and press **OK**.
A third *Please specify the Conductivity Standard...* dialog box appears.

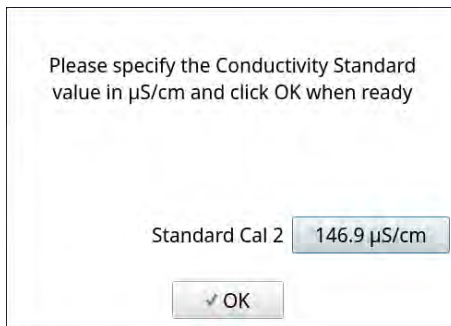

Please specify the Conductivity Standard value in $\mu\text{S}/\text{cm}$ and click OK when ready

Standard Cal 2 146.9 $\mu\text{S}/\text{cm}$

✓ OK

- 5.8.8 Leave the default value in the *Standard Value* field or press inside the field to use the numeric keypad to enter a new value and press **OK**. The Analyzer begins analysis of the vial set.



NOTE: If using individual vials, follow the on-screen prompts for each vial as shown in the standard iOS instructions at step [5.9](#).

- 5.8.9 When analysis of the vial set is complete, remove it from the Super iOS. If a *Rinse After...* option was selected, follow the on-screen prompts for rinsing.
- 5.8.10 Go to step [5.10](#).

5.9 If using a standard iOS System:



5.9.1 A Conductivity Temperature Compensation dialog box appears.

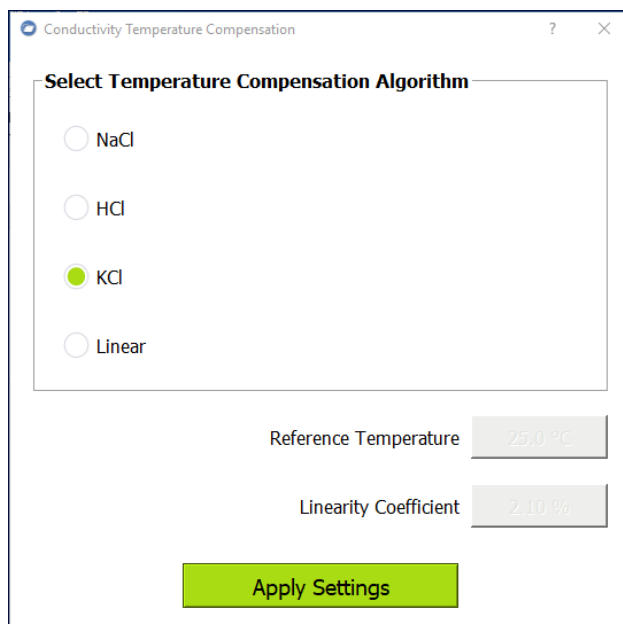

5.9.2 Select the temperature compensation algorithm from the list of options and press **APPLY SETTINGS** to continue.

5.9.3 A *Please specify the Conductivity Standard...* dialog box appears.



NOTE: The conductivity standard value is user-definable within the specified range.

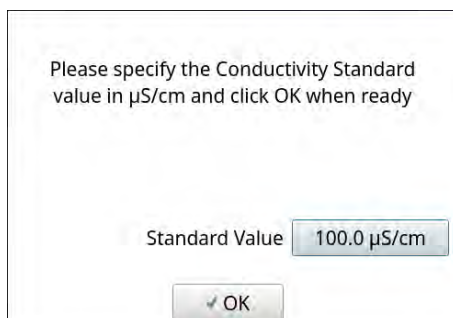

- 5.9.4 Leave the default value in the *Standard Value* field or press inside the field to use the numeric keypad to enter a new value and press **OK**.

A second *Please specify the Conductivity Standard...* dialog box appears.

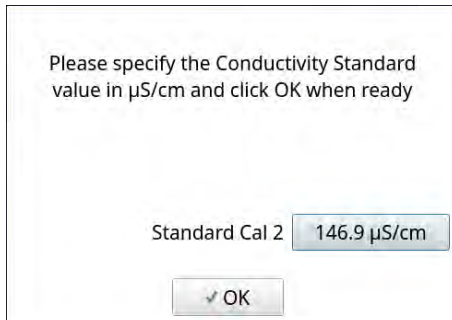

Please specify the Conductivity Standard value in $\mu\text{S}/\text{cm}$ and click OK when ready

Standard Cal 2 146.9 $\mu\text{S}/\text{cm}$

✓ OK

- 5.9.5 Leave the default value in the *Standard Value* field or press inside the field to use the numeric keypad to enter a new value and press **OK**.

A third *Please specify the Conductivity Standard...* dialog box appears.

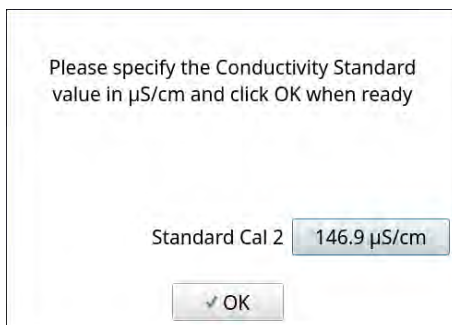

Please specify the Conductivity Standard value in $\mu\text{S}/\text{cm}$ and click OK when ready

Standard Cal 2 146.9 $\mu\text{S}/\text{cm}$

✓ OK

- 5.9.6 Leave the default value in the *Standard Value* field or press inside the field to use the numeric keypad to enter a new value and press **OK**. A *Please insert the 100 $\mu\text{S}/\text{cm}$ vial...* dialog box appears.



Please insert the <100 $\mu\text{S}/\text{cm}$ Cond> vial and click the button when ready, in order to continue running the protocol.

Vial ready -> Continue

- 5.9.7 Open the door to the iOS System and wait 30 seconds for water to drain.
- 5.9.8 Insert the **100 $\mu\text{S}/\text{cm}$ Cond** vial into the iOS System and press **VIAL READY-> CONTINUE**. The Analyzer begins analysis of the vial.



- 5.9.9 When analysis of the 100 $\mu\text{S}/\text{cm}$ Cond vial is complete, a *Please insert the 146.9 $\mu\text{S}/\text{cm}$ (or other selected standard) vial...* dialog box appears.

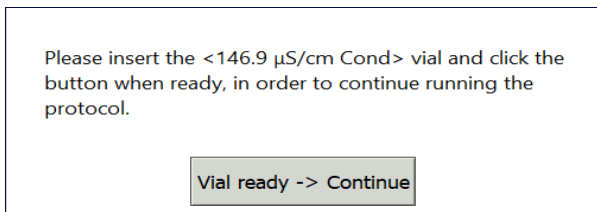

- 5.9.10 Remove the 100 $\mu\text{S}/\text{cm}$ Cond vial, then insert the 146.9 $\mu\text{S}/\text{cm}$ Cond vial into the iOS System and press **VIAL READY-> CONTINUE**. The Analyzer begins analysis of the vial.

- 5.9.11 When analysis of the 146.9 $\mu\text{S}/\text{cm}$ Cond vial is complete, a *Please insert the 718 $\mu\text{S}/\text{cm}$ (or other selected standard) vial...* dialog box appears.

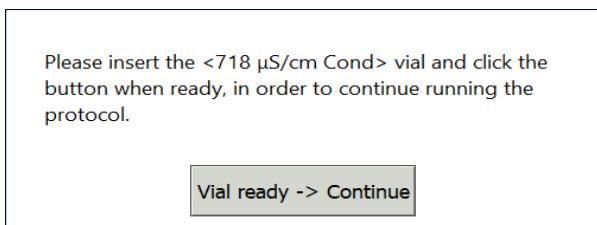

- 5.9.12 Remove the 146.9 $\mu\text{S}/\text{cm}$ Cond vial, then insert the 718 $\mu\text{S}/\text{cm}$ Cond vial into the iOS System and press **VIAL READY-> CONTINUE**. The Analyzer begins analysis of the vial.

- 5.9.13 When analysis of the vial is complete, remove it from the iOS and press **VIAL REMOVED -> CONTINUE**.

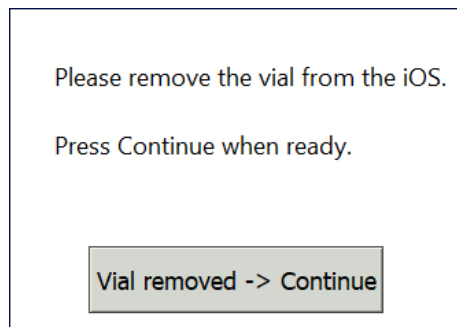

5.10 The *Sample Conductivity Multi-point Calibration: Protocol Complete* screen appears with the *Summary* tab active and multiple tabs available for reviewing, as follows:

	Value	Limit	Result
100.0 µS/cm Standard RSD	0.00 %	≤ 0.50 %	Passed
147.0 µS/cm Standard RSD	0.00 %	≤ 0.50 %	Passed
718.0 µS/cm Standard RSD	0.01 %	≤ 0.50 %	Passed
Cell Constant % Difference	1.50 %	± 50.0 %	Passed
Regression Slope	1.001	N/A	N/A
Square of Correlation Coefficient (R ²)	1.000	≥ 0.990	Passed
Old Sample Cell Constant	1.0112	N/A	N/A
New Sample Cell Constant	1.0264	N/A	N/A

- Vial 1–3 — Select a tab to view analysis details for each standard, as needed.
- Summary — Select this tab to view the summary of analysis, including a *passed* or *failed* result. It also contains **APPLY**, **REJECT**, **PRINT**, **EXPORT**, and **CLOSE** buttons.

5.11 Referencing the *Summary* tab, record the results data on the *Sample Conductivity Multi-point Calibration Worksheet*.

5.12 Do one of the following:

- 5.12.1 If the calibration *passed*, press **APPLY** to accept the calibration. A confirmation message appears. Press **APPLY CALIBRATION**, then **CLOSE**.

Are you sure you want to apply this calibration to your analyzer ?

Go back to Summary Apply calibration

- 5.12.2 If the calibration *failed*, leave the screen as is and contact Technical Support or your local service provider. Before calling, e-mail the backup and system settings files (created in advance of running calibration protocols). After analysis of the data, you may be advised to accept the results or to pursue additional troubleshooting steps.

5.13 To print or export the results, press the corresponding button.

TC/IC Conductivity Autozero Protocol

1.0 INTRODUCTION

Perform the following TC/IC Conductivity Autozero Protocol to calibrate the TC and IC conductivity offsets of a Sievers M500 TOC Analyzer.

2.0 SCOPE

This procedure applies to the Sievers M500 TOC Analyzer.

3.0 MATERIALS

- 3.1 Sievers M500 TOC Analyzer
- 3.2 *TC/IC Conductivity Autozero Worksheet*

4.0 DEFINITIONS

- 4.1 NONE

5.0 PROCEDURE

- 5.1 (*OPTIONAL*) If DataGuard is enabled, log in to the Analyzer with a User ID and the appropriate password.
- 5.2 If the Analyzer is taking measurements, press **STOP ANALYSIS** .
- 5.3 Export the current system settings for future reference or reloading by following the steps in ["To save the system settings" on page 222](#).
- 5.4 Back up the database and settings by following the steps in ["To back up the database and settings" on page 223](#).

Chapter 6 CALIBRATION AND SYSTEM PROTOCOLS

5.5 On the *System Protocols* screen, select the *Calibration* tab.

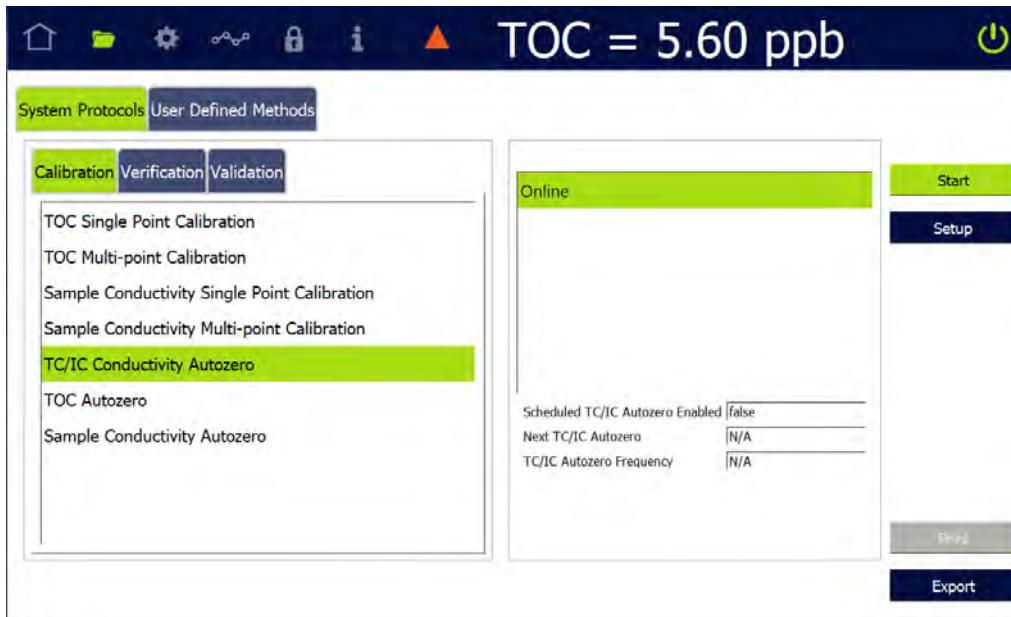

5.6 Select **TC/IC Conductivity Autozero** and press **START**.

5.7 The *TC/IC Conductivity Results* screen appears as follows:

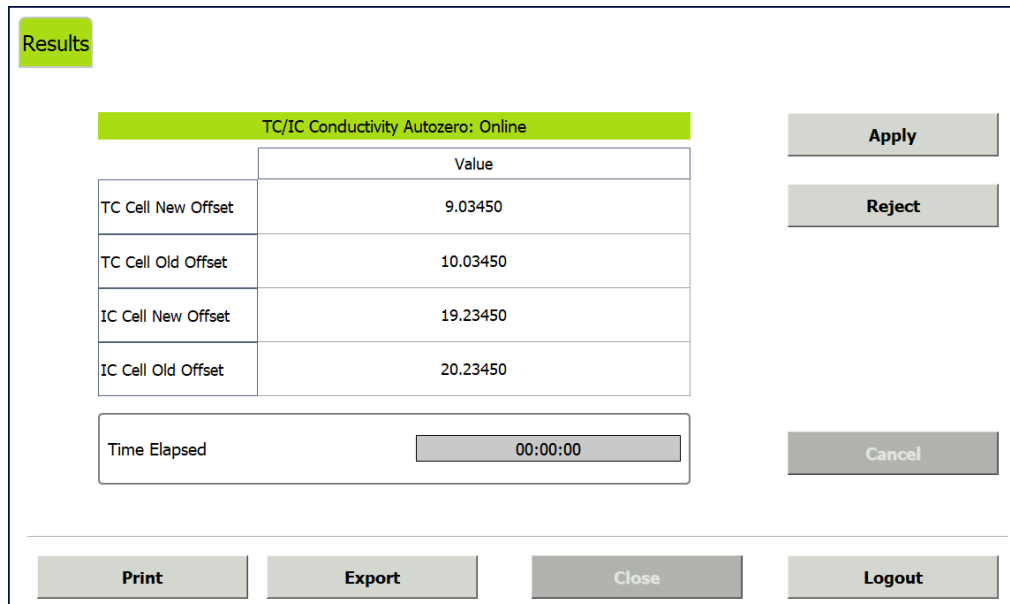

- Summary — The summary of calibration, including the old and new offset values. It also contains the **APPLY** and **REJECT** buttons, as well as the **PRINT** and **EXPORT** buttons.

5.8 Referencing the *Summary* tab, record the results data on the *TC/IC Conductivity Autozero Worksheet*.



5.9 Do one of the following:

5.9.1 Press **APPLY** to accept the new offset. A confirmation message appears. Press **APPLY CALIBRATION**, then **CLOSE**.

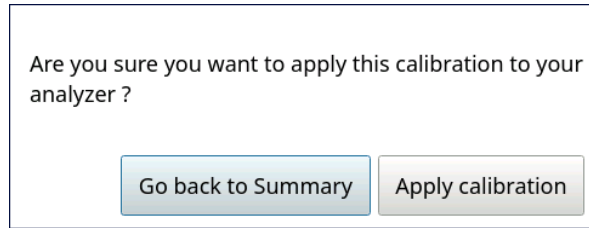

5.9.2 Press **REJECT** to reject the new offset. A confirmation message appears. Press **REJECT CALIBRATION**, then **CLOSE**.

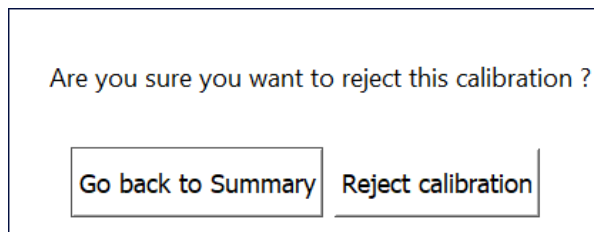

5.10 To print or export the results, press the corresponding button.

TOC Autozero Calibration Protocol

1.0 INTRODUCTION

Perform the following TOC Autozero Calibration Protocol to calibrate the TOC offset of a Sievers M500 TOC Analyzer.

2.0 SCOPE

This procedure applies to the Sievers M500 TOC Analyzer.

3.0 MATERIALS



NOTE: Use *only* Sievers standards purchased from SUEZ.

- 3.1 Sievers M500 TOC Analyzer
- 3.2 *TOC Autozero Calibration Worksheet*

4.0 DEFINITIONS

- 4.1 NONE

5.0 PROCEDURE

- 5.1 (**OPTIONAL**) If DataGuard is enabled, log in to the Analyzer with a User ID and the appropriate password.
- 5.2 If the Analyzer is taking measurements, press **STOP ANALYSIS** .
- 5.3 Export the current system settings for future reference or reloading by following the steps in ["To save the system settings" on page 222](#).
- 5.4 Back up the database and settings by following the steps in ["To back up the database and settings" on page 223](#).

5.5 On the *System Protocols* screen, select the *Calibration* tab.

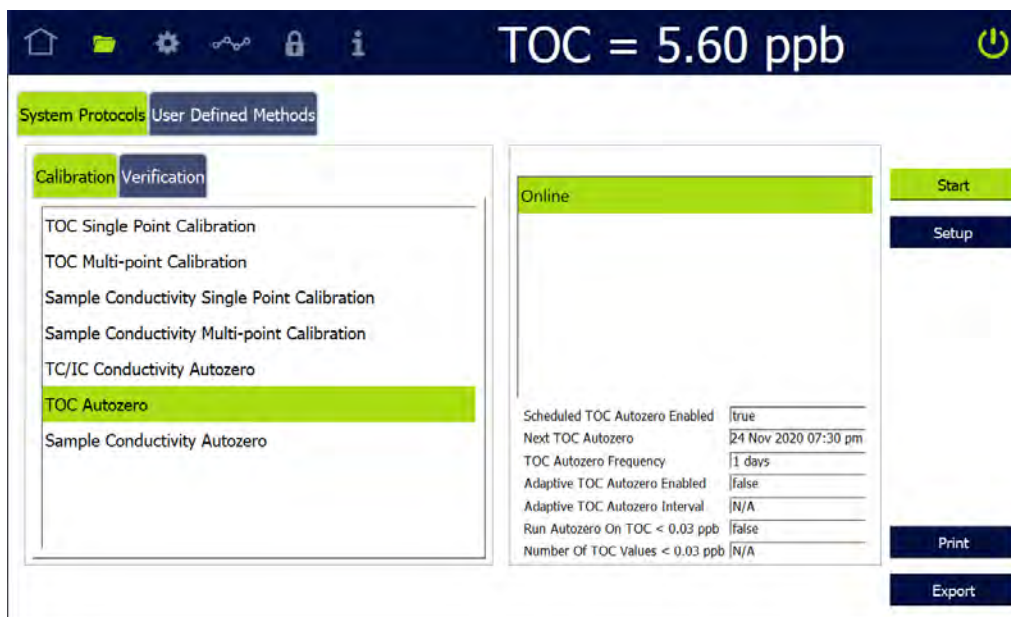

5.6 Select **TOC Autozero** and press **START**.

5.7 After analysis is complete, the *Calibration Summary* screen appears with the summary of analysis, including a *passed* or *failed* result. It also contains the **APPLY** and **REJECT** buttons, as well as the **PRINT** and **EXPORT** buttons.

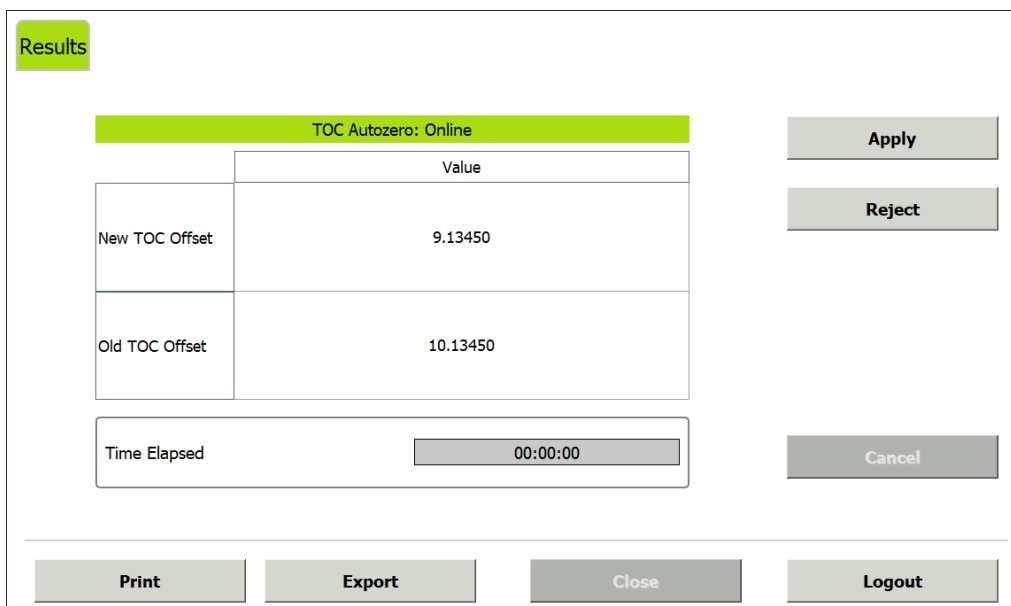

5.8 Referencing the *Summary* screen, record the results data on the *TOC Autozero Calibration Worksheet*.

5.9 Do one of the following:

5.9.1 Press **APPLY** to accept the new offset. A confirmation message appears. Press **APPLY CALIBRATION**, then **CLOSE**.

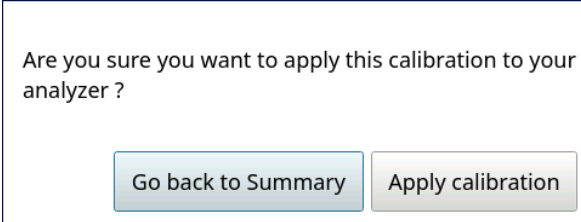

Are you sure you want to apply this calibration to your analyzer ?

Go back to Summary Apply calibration

5.9.2 Press **REJECT** to reject the new offset. A confirmation message appears. Press **REJECT CALIBRATION**, then **CLOSE**.

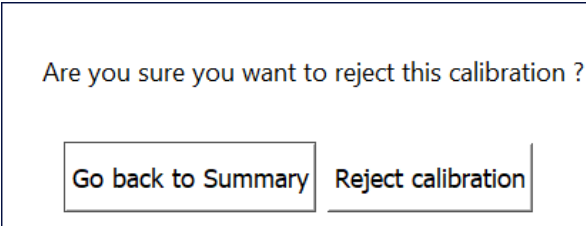

Are you sure you want to reject this calibration ?

Go back to Summary Reject calibration

5.10 To print or export the results, press the corresponding button.

Sample Conductivity Autozero Protocol

1.0 INTRODUCTION

Perform the following Sample Conductivity Autozero Protocol to calibrate the sample conductivity cell offset of a Sievers M500 TOC Analyzer.

2.0 SCOPE

This procedure applies to the Sievers M500 TOC Analyzer.

3.0 MATERIALS



NOTE: Use *only* Sievers standards purchased from SUEZ.

- 3.1 Sievers M500 TOC Analyzer
- 3.2 *Sample Conductivity Autozero Worksheet*

4.0 DEFINITIONS

- 4.1 NONE

5.0 PROCEDURE

- 5.1 (**OPTIONAL**) If DataGuard is enabled, log in to the Analyzer with a User ID and the appropriate password.
- 5.2 If the Analyzer is taking measurements, press **STOP ANALYSIS** .
- 5.3 Export the current system settings for future reference or reloading by following the steps in ["To save the system settings" on page 222](#).
- 5.4 Back up the database and settings by following the steps in ["To back up the database and settings" on page 223](#).

Chapter 6 CALIBRATION AND SYSTEM PROTOCOLS

5.5 On the *System Protocols* screen, select the *Calibration* tab.

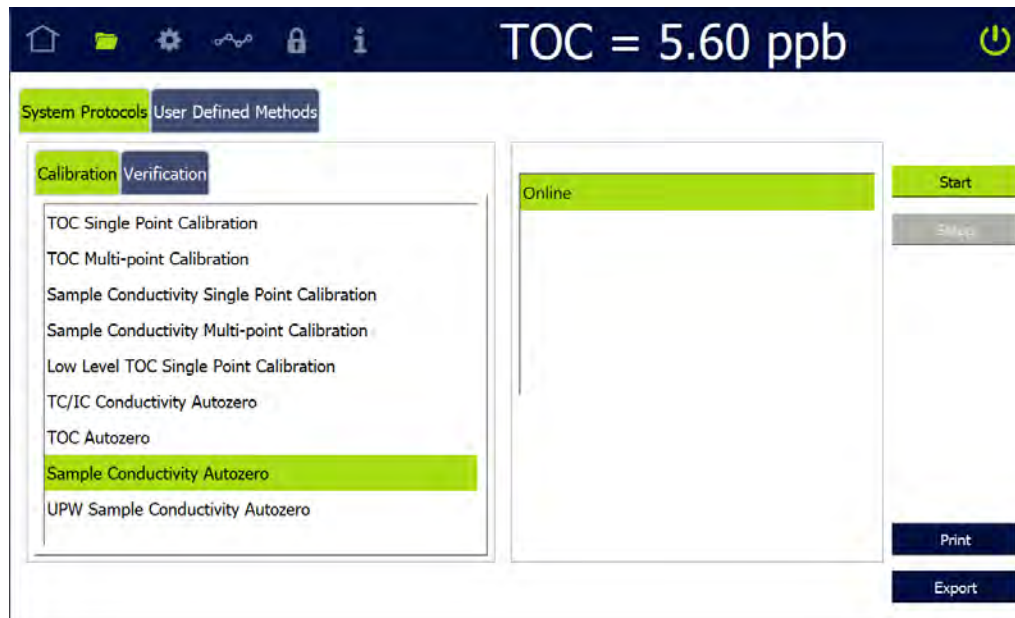

5.6 Select **Sample Conductivity Autozero** and press **START**. A *Please specify the Conductivity Standard value...* dialog box appears:

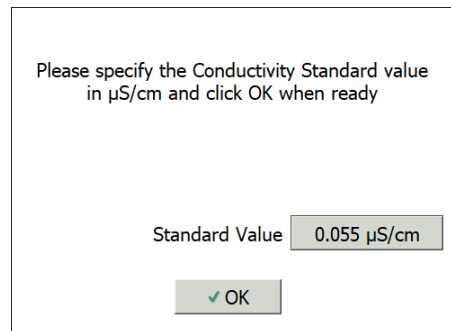

5.7 Leave the default value in the *Standard Value* field or press inside the field to use the numeric keypad to enter a new value and press **OK**.



- 5.8 After analysis is complete, the *Sample Conductivity Autozero: 0.055* (or selected value) $\mu\text{S}/\text{cm}$ Reference screen appears with the summary of analysis, including a *passed* or *failed* result. It also contains the **APPLY** and **REJECT** buttons, as well as the **PRINT** and **EXPORT** buttons.

The screenshot shows a 'Results' screen with a green header bar containing the text 'Sample Conductivity Autozero: 0.055 $\mu\text{S}/\text{cm}$ Reference'. Below this is a table with two columns: 'New Sample Cell Offset' and 'Old Sample Cell Offset', and a 'Value' column. A 'Time Elapsed' field shows '00:00:14'. On the right side, there are three buttons: 'Apply', 'Reject', and 'Cancel'. At the bottom, there are four buttons: 'Print', 'Export', 'Close', and 'Logout'.

- 5.9 Referencing the *Summary* screen, record the results data on the *Sample Conductivity Autozero Worksheet*.

5.10 Do one of the following:

- 5.10.1 Press **APPLY** to accept the new offset. A confirmation message appears. Press **APPLY CALIBRATION**, then **CLOSE**.

The dialog box contains the text 'Are you sure you want to apply this calibration to your analyzer?' and two buttons: 'Go back to Summary' and 'Apply calibration'.

- 5.10.2 Press **REJECT** to reject the new offset. A confirmation message appears. Press **REJECT CALIBRATION**, then **CLOSE**.

The dialog box contains the text 'Are you sure you want to reject this calibration?' and two buttons: 'Go back to Summary' and 'Reject calibration'.

5.11 To print or export the results, press the corresponding button.

System Suitability Protocol

1.0 INTRODUCTION

Perform the following System Suitability Protocol to verify suitability (response efficiency) of the Sievers M500 TOC Analyzer for its intended use.

2.0 SCOPE

This procedure applies to the Sievers M500 TOC Analyzer.

3.0 MATERIALS



NOTE: Use *only* Sievers standards purchased from SUEZ.

- 3.1 Sievers M500 TOC Analyzer
- 3.2 *System Suitability Worksheet*
- 3.3 **System Suitability Standard Set:**
 - 3.3.1 One vial — **Rw Blank**
 - 3.3.2 One vial — **500 ppb Rs**
 - 3.3.3 One vial — **500 ppb Rss**
 - 3.3.4 (**OPTIONAL WHEN USING THE SUPER IOS**) SUEZ recommends the **Flush Set** for rinsing before, after, **or** before and after running the protocol.

4.0 DEFINITIONS

- 4.1 NONE

5.0 PROCEDURE

- 5.1 (**OPTIONAL**) If DataGuard is enabled, log in to the Analyzer with a User ID and the appropriate password.
- 5.2 If the Analyzer is taking measurements, press **STOP ANALYSIS** .

5.3 On the *System Protocols* screen, select the *Verification* tab.

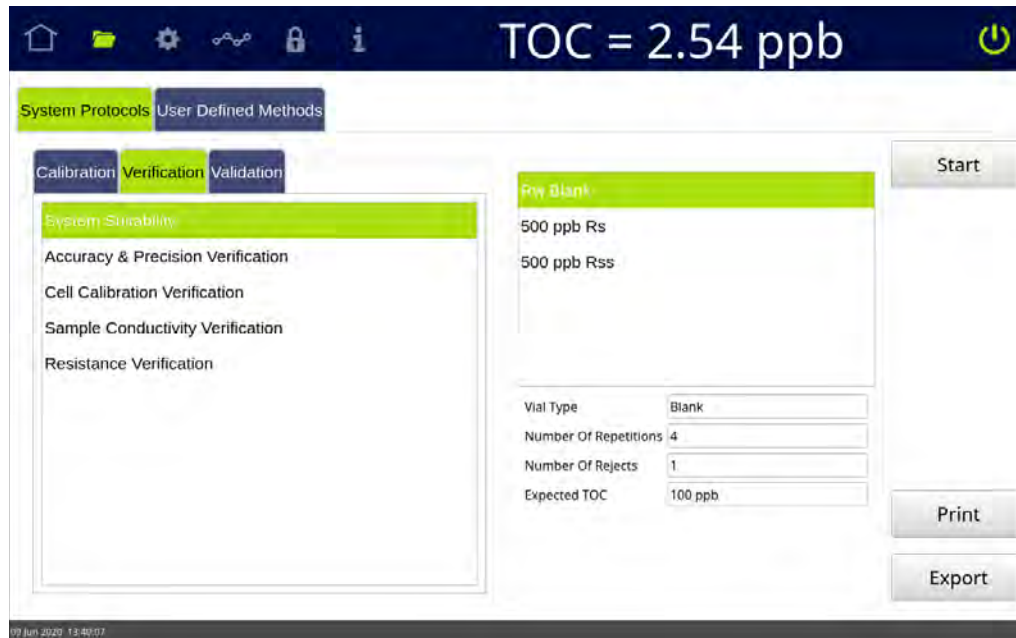

5.4 Select **System Suitability** and press **START**.

5.5 If using a standard iOS system, go to step [5.7](#).

5.6 If using a Super iOS System, follow the prompts for the drain and rinse options (described in "[Super iOS Drain/Rinse](#)" on page 228).

5.6.1 A *Please insert...* dialog box appears.

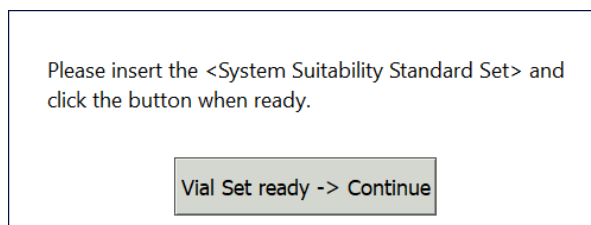

5.6.2 Insert the **System Suitability Standard Set** and press **VIAL SET READY-> CONTINUE**.

If using individual vials, **do not** insert them. Press **VIAL SET READY-> CONTINUE**. See "[Using Individual Vials in the Super iOS](#)" on page 229 for more information.

- Port 1 = **Rw Blank**
- Port 2 = **500 ppb Rs**
- Port 3 = **500 ppb Rss**

- 5.6.3 When analysis of the vial set is complete, remove it from the Super iOS. If a *Rinse After...* option was selected, follow the on-screen prompts for rinsing.
- 5.6.4 Go to step [5.8](#).
- 5.7 If using a standard iOS System:
- 5.7.1 A *Please insert the Rw Blank vial...* dialog box appears.

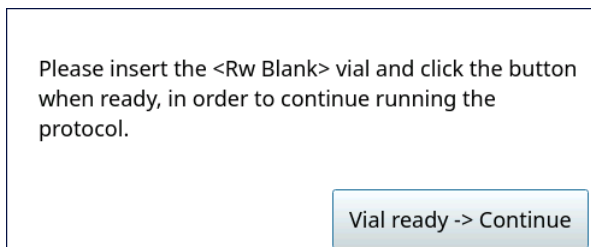

- 5.7.2 Open the door to the iOS System and wait 30 seconds for water to drain.
- 5.7.3 Insert the **Rw Blank** vial into the iOS System and press **VIAL READY-> CONTINUE**. The Analyzer begins analysis of the vial.
- 5.7.4 When analysis of the **Rw Blank** vial is complete, a *Please insert the 500 ppb Rs vial...* dialog box appears.

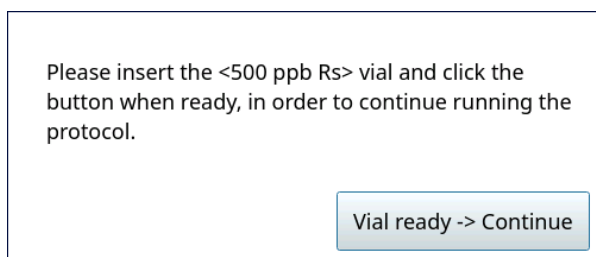

- 5.7.5 Remove the **Rw Blank** vial, then insert the **500 ppb Rs** vial into the iOS System and press **VIAL READY-> CONTINUE**. The Analyzer begins analysis of the vial.
- 5.7.6 When analysis of the **500 ppb Rs** vial is complete, a *Please insert the 500 ppb Rss vial...* dialog box appears.

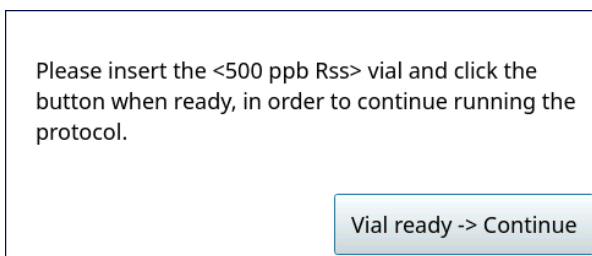

- 5.7.7 Remove the **500 ppb Rs** vial, then insert the **500 ppb Rss** vial into the iOS System and press **VIAL READY-> CONTINUE**. The Analyzer begins analysis of the vial.



5.7.8 When analysis of the vial is complete, remove it from the iOS and press **VIAL REMOVED -> CONTINUE**.

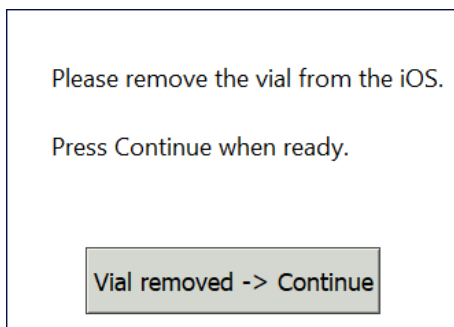

5.8 The *System Suitability: Protocol Complete* screen appears with the *Summary* tab active and multiple tabs available for reviewing, as follows:

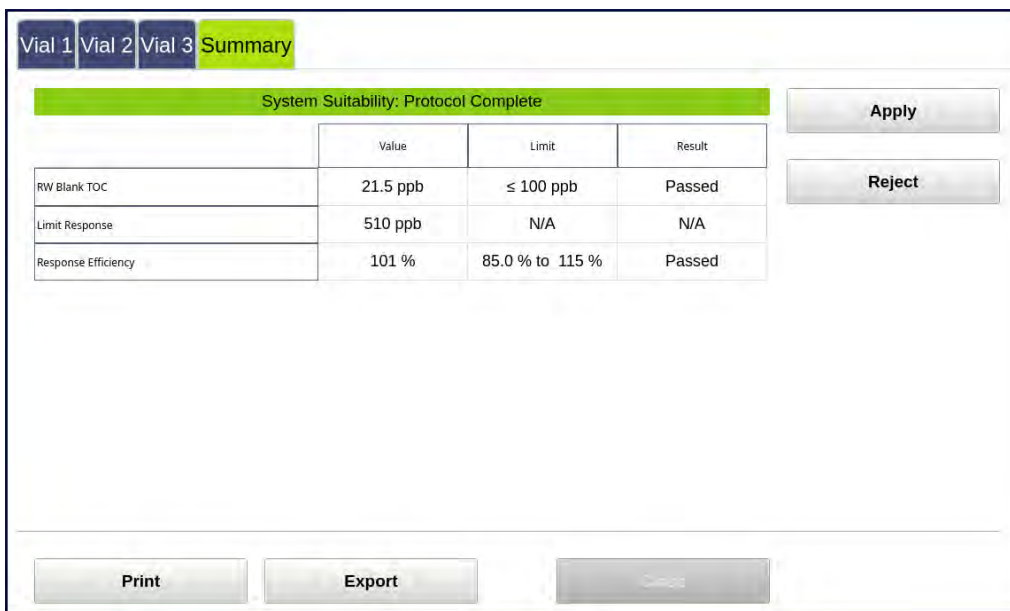

- Vial 1–3 — Select a tab to view analysis details for each standard, as needed.
- Summary — Select this tab to view the summary of analysis, including a *passed* or *failed* result. It also contains the **APPLY**, **REJECT**, **PRINT**, and **EXPORT** buttons.

5.9 Referencing the *Summary* tab, record the results data on the *System Suitability Worksheet*.

5.10 If the verification *failed*, leave the screen as is and contact Technical Support or your local service provider. Before calling, e-mail the backup and system settings files (created in advance of running calibration protocols). After analysis of the data, you may be advised to accept the results or to pursue additional troubleshooting steps.

5.11 To print or export the results, press the corresponding button.

Accuracy & Precision Verification Protocol

1.0 INTRODUCTION

Perform the following Accuracy & Precision Protocol to verify the TOC accuracy and precision of a Sievers M500 TOC Analyzer.

2.0 SCOPE

This procedure applies to the Sievers M500 TOC Analyzer.

3.0 MATERIALS



NOTE: Use *only* Sievers standards purchased from SUEZ.

- 3.1 Sievers M500 TOC Analyzer
- 3.2 *Accuracy & Precision Verification Worksheet*
- 3.3 **Accuracy/Precision Verification Standard Set:**
 - 3.3.1 One vial — **Rw Blank**
 - 3.3.2 One vial — **500 ppb TOC**
- 3.4 (**OPTIONAL WHEN USING THE SUPER IOS**) SUEZ recommends the **Flush Set** for rinsing before, after, **or** before and after running the protocol.

4.0 DEFINITIONS

- 4.1 NONE

5.0 PROCEDURE

- 5.1 (**OPTIONAL**) If DataGuard is enabled, log in to the Analyzer with a User ID and the appropriate password.
- 5.2 If the Analyzer is taking measurements, press **STOP ANALYSIS** .



5.3 On the *System Protocols*  screen, select the *Verification* tab.

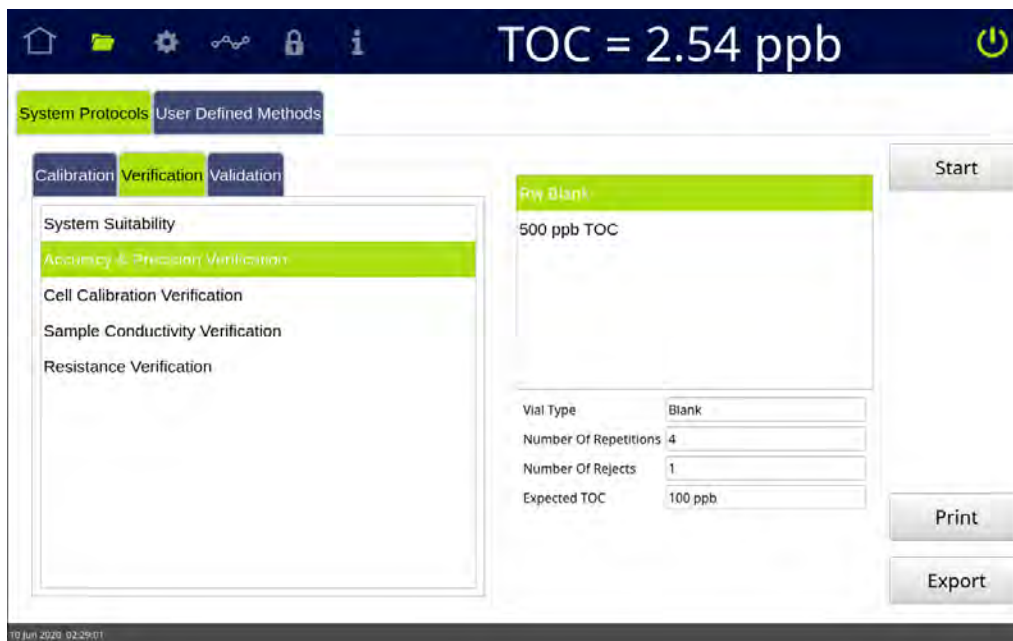

5.4 Select **Accuracy & Precision Verification**, then press **START**.

5.5 If using a standard iOS System, go to step [5.7](#).

5.6 If using a Super iOS System, follow the prompts for the drain and rinse options (described in ["Super iOS Drain/Rinse" on page 228](#)).

5.6.1 A *Please insert...* dialog box appears.

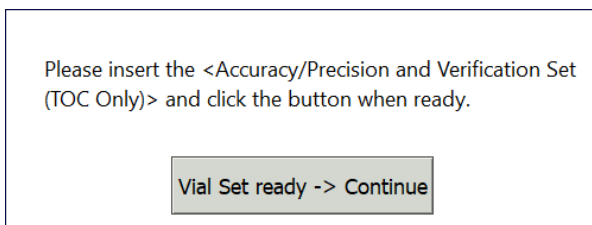

5.6.2 Insert the **Accuracy/Precision Verification Standard Set** and press **VIAL SET READY-> CONTINUE**.

If using individual vials, **do not** insert them. Press **VIAL SET READY-> CONTINUE**. See ["Using Individual Vials in the Super iOS" on page 229](#) for more information.

- Port 2 = **Rw Blank**
- Port 3 = **500 ppb TOC**

- 5.6.3 When analysis of the vial set is complete, remove it from the Super iOS. If a *Rinse After...* option was selected, follow the on-screen prompts for rinsing.
- 5.6.4 Go to step [5.8](#).
- 5.7 If using a standard iOS System:
- 5.7.1 A *Please insert the Rw Blank...* dialog box appears.

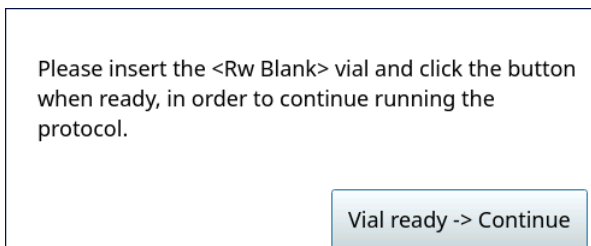

- 5.7.2 Open the door to the iOS System and wait 30 seconds for water to drain.
- 5.7.3 Insert the **Rw Blank** vial into the iOS System and press **VIAL READY-> CONTINUE**. The Analyzer begins analysis of the vial.
- 5.7.4 When analysis of the **Rw Blank** vial is complete, a *Please insert the 500 ppb...* dialog box appears.

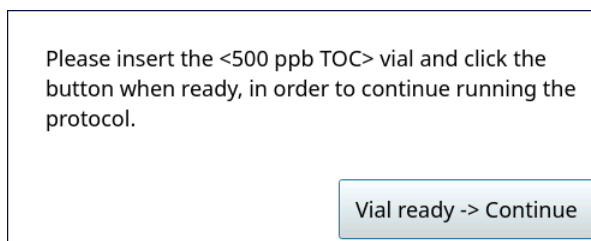

- 5.7.5 Remove the **Rw Blank** vial, then insert the **500 ppb TOC** vial into the iOS System and press **VIAL READY-> CONTINUE**. The Analyzer begins analysis of the vial.
- 5.7.6 When analysis of the vial is complete, remove it from the iOS and press **VIAL REMOVED -> CONTINUE**.

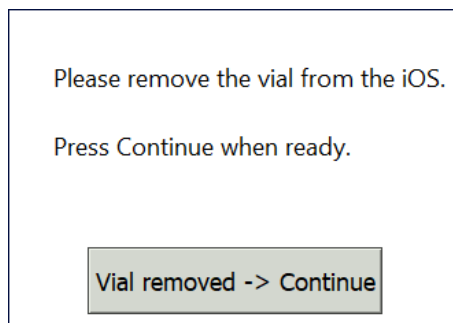



5.8 The *Accuracy & Precision Verification: Protocol Complete* screen appears with the *Summary* tab active and multiple tabs available for reviewing, as follows:

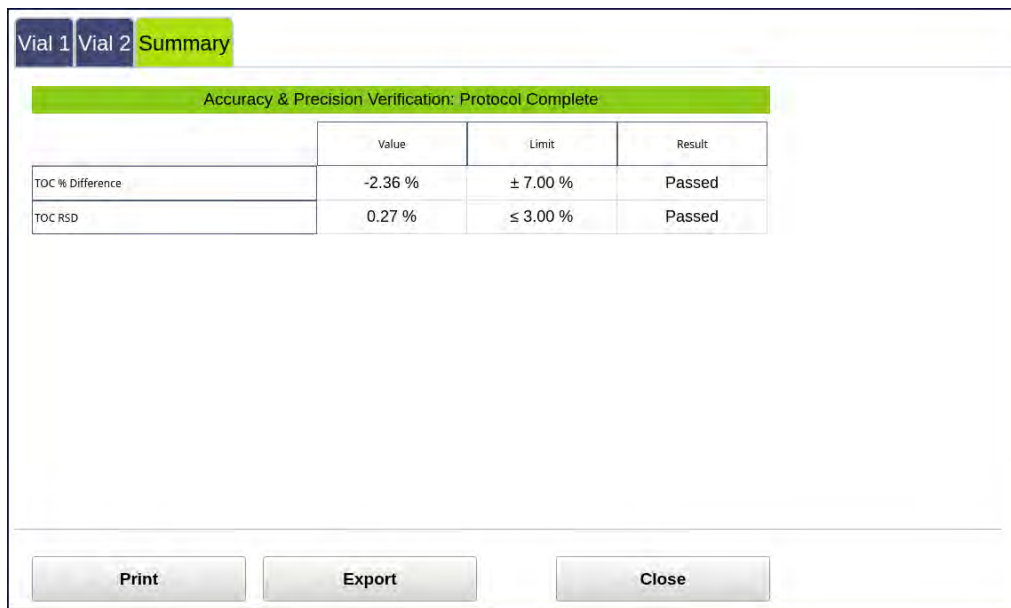

- Vial 1–2 — Select a tab to view analysis details for each standard, as needed.
- Summary — Select this tab to view the summary of analysis, including a *passed* or *failed* result. It also contains the **PRINT**, **EXPORT**, and **CLOSE** buttons.

5.9 Referencing the *Summary* tab, record the results data on the *Accuracy & Precision Verification Worksheet*.

5.10 If the verification failed, leave the screen as is and contact Technical Support or your local service provider. Before calling, e-mail the backup and system settings files (created in advance of running calibration protocol). After analysis of the data, you may be advised to pursue troubleshooting steps.

5.11 To print or export the results, press the corresponding button.

Cell Calibration Verification Protocol

1.0 INTRODUCTION

Perform the following Cell Calibration Verification Protocol to verify the cell calibration of a Sievers M500 TOC Analyzer.

2.0 SCOPE

This procedure applies to the Sievers M500 TOC Analyzer. The instrument should be calibrated and the analyst performing this protocol should be familiar with the terminology and operation of the Analyzer.

3.0 MATERIALS



NOTE: Use *only* Sievers standards purchased from SUEZ.

- 3.1 Sievers M500 TOC Analyzer
- 3.2 *Cell Calibration Verification Protocol Worksheet*
- 3.3 **25 µS/cm Conductivity Verification Set**
 - 3.3.1 One vial — **Rinse**
 - 3.3.2 One vial — **25 µS/cm Cond**
- 3.4 **(OPTIONAL WHEN USING THE SUPER IOS)** SUEZ recommends the **Flush Set** for rinsing before, after, **or** before and after running the protocol.

4.0 DEFINITIONS

- 4.1 NONE

5.0 PROCEDURE

- 5.1 **(OPTIONAL)** If DataGuard is enabled, log in to the Analyzer with a User ID and the appropriate password.
- 5.2 If the Analyzer is taking measurements, press **STOP ANALYSIS** .



5.3 On the *System Protocols*  screen, select the *Verification* tab.

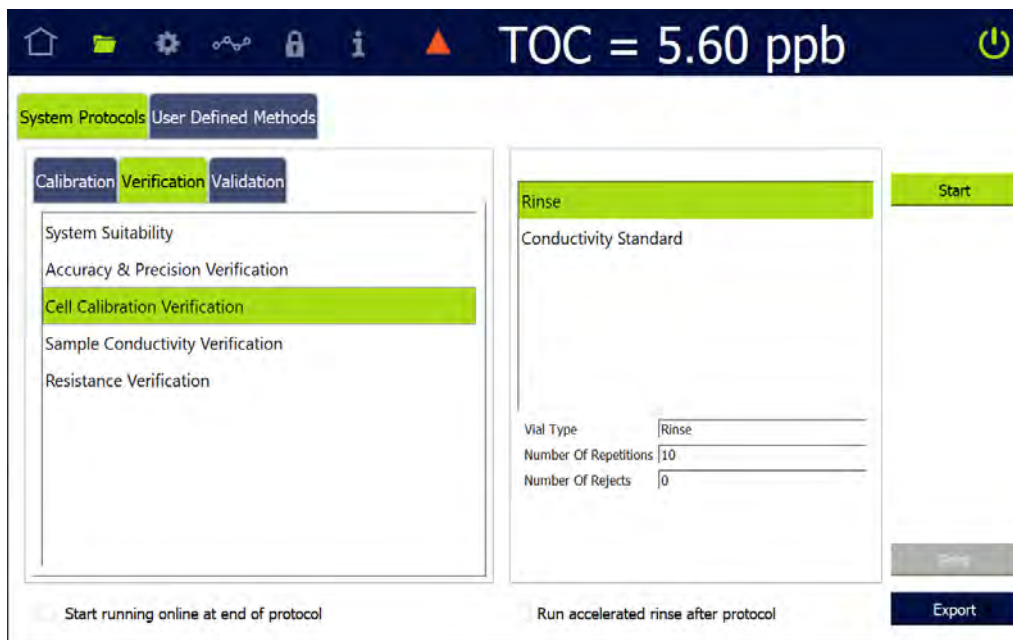

5.4 Select **Cell Calibration Verification**, then press **START**.

5.5 If using a standard iOS System, go to step [5.7](#).

5.6 If using a Super iOS System, follow the prompts for the drain and rinse options (described in ["Super iOS Drain/Rinse" on page 228](#)).

5.6.1 A *Please insert...* dialog box appears.

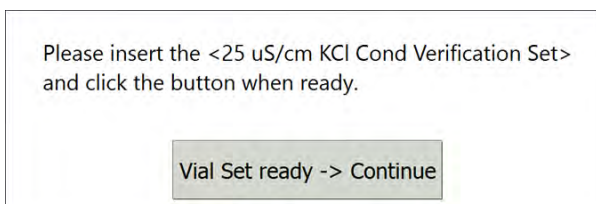

5.6.2 Insert the **25 μ S/cm Conductivity Verification Set** and press **VIAL SET READY-> CONTINUE**, then go to step [5.6.7](#).

If using individual vials, **do not** insert them. Press **VIAL SET READY-> CONTINUE**. See ["Using Individual Vials in the Super iOS" on page 229](#) for more information.

- Port 2 = Rinse
- Port 3 = 25 μ S/cm Cond

- 5.6.3 **(Individual vials only)** A Conductivity Temperature Compensation dialog box appears.

- 5.6.4 Select the temperature compensation algorithm from the list of options and press **APPLY SETTINGS** to continue.
- 5.6.5 A *Please specify the Conductivity Standard value...* dialog box appears.



NOTE: The conductivity standard value is user-definable, but for the purposes of calibration, use the default value.

- 5.6.6 Leave the default value in the *Standard Value* field or press inside the field to use the numeric keypad to enter a new value and press **OK**.
- 5.6.7 When analysis of the vial set is complete, remove it from the Super iOS. If a *Rinse After...* option was selected, follow the on-screen prompts for rinsing.
- 5.6.8 Go to step [5.8](#).

5.7 If using a standard iOS System:



5.7.1 A Conductivity Temperature Compensation dialog box appears.

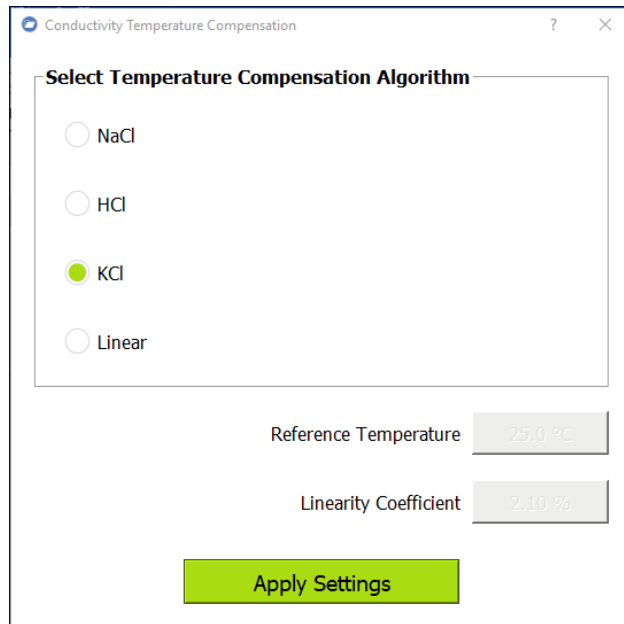

5.7.2 Select the temperature compensation algorithm from the list of options and press **APPLY SETTINGS** to continue.

5.7.3 A *Please specify the Conductivity Standard value...* dialog box appears.



NOTE: The conductivity standard value is user-definable within the specified range.

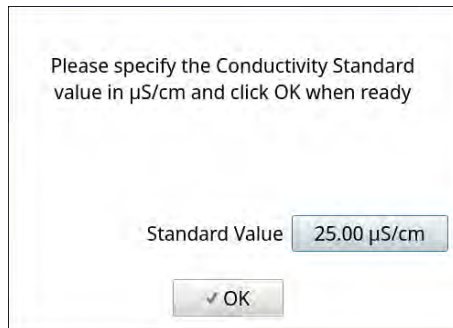

5.7.4 Leave the default value in the *Standard Value* field or press inside the field to use the numeric keypad to enter a new value and press **OK**.

5.7.5 A *Please insert the Rinse vial...* dialog box appears.

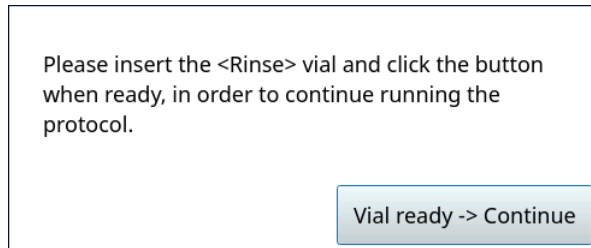

5.7.6 Open the door to the iOS System and wait 30 seconds for water to drain.

5.7.7 Insert the **Rinse** vial into the iOS System and press **VIAL READY-> CONTINUE**.

5.7.8 When analysis of the **Rinse** vial is complete, a *Please insert the 25 µS/cm vial...* dialog box appears.

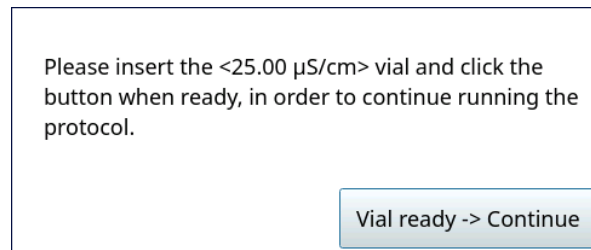

5.7.9 Remove the **Rinse** vial, then insert the **25 µS/cm Cond** vial into the iOS System and press **VIAL READY-> CONTINUE**. The Analyzer begins analysis of the vial.

5.7.10 When analysis of the vial is complete, remove it from the iOS and press **VIAL REMOVED -> CONTINUE**.

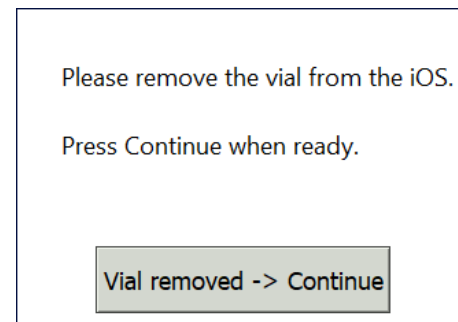



5.8 The *Cell Calibration Verification: Protocol Complete* screen appears with the *Summary* tab active and two tabs available for reviewing, as follows:

	Value	Limit	Result
Conductivity % Difference	-0.48 %	± 2.00 %	Passed
Conductivity RSD	0.02 %	≤ 1.00 %	Passed

- Vial 1–2 — Select these tabs to view analysis details for each vial, as needed.
- Summary — Select this tab to view the summary of analysis, including *passed* or *failed* results. It also contains the **CLOSE**, **PRINT**, and **EXPORT** buttons.

5.9 Referencing the *Summary* tab, record the results data on the *Cell Calibration Verification Protocol Worksheet*.

5.10 If the verification failed, leave the screen as is and contact Technical Support or your local service provider. Before calling, e-mail the backup and system settings files (created in advance of running calibration protocol). After analysis of the data, you may be advised to pursue troubleshooting steps.

5.11 To print or export the results, press the corresponding button.

Sample Conductivity Verification Protocol

1.0 INTRODUCTION

Perform the following Sample Conductivity Verification Protocol to verify the sample conductivity response of a Sievers M500 TOC Analyzer. Sample conductivity verification utilizes a single conductivity standard to verify the sample conductivity response. This protocol is similar to cell calibration verification but in this protocol the user can set the accuracy pass/fail criteria.

2.0 SCOPE

This procedure applies to the Sievers M500 TOC Analyzer.

3.0 MATERIALS



NOTE: Use *only* Sievers standards purchased from SUEZ.

- 3.1 Sievers M500 TOC Analyzer
- 3.2 *Sample Conductivity Verification Worksheet*
- 3.3 **25 μ S/cm KCl Conductivity Verification Set:**
 - 3.3.1 One vial — **Rinse**
 - 3.3.2 One vial — **25 μ S/cm Cond**
 - 3.3.3 (**OPTIONAL WHEN USING THE SUPER IOS**) SUEZ recommends the **Flush Set** for rinsing before, after, **or** before and after running the protocol.

4.0 DEFINITIONS

- 4.1 NONE

5.0 PROCEDURE

- 5.1 (**OPTIONAL**) If DataGuard is enabled, log in to the Analyzer with a User ID and the appropriate password.
- 5.2 If the Analyzer is taking measurements, press **STOP ANALYSIS** .
- 5.3 Export the current system settings for future reference or reloading by following the steps in ["To save the system settings" on page 222](#).
- 5.4 Back up the database and settings by following the steps in ["To back up the database and settings" on page 223](#).

5.5 On the *System Protocols* screen, select the *Verification* tab.

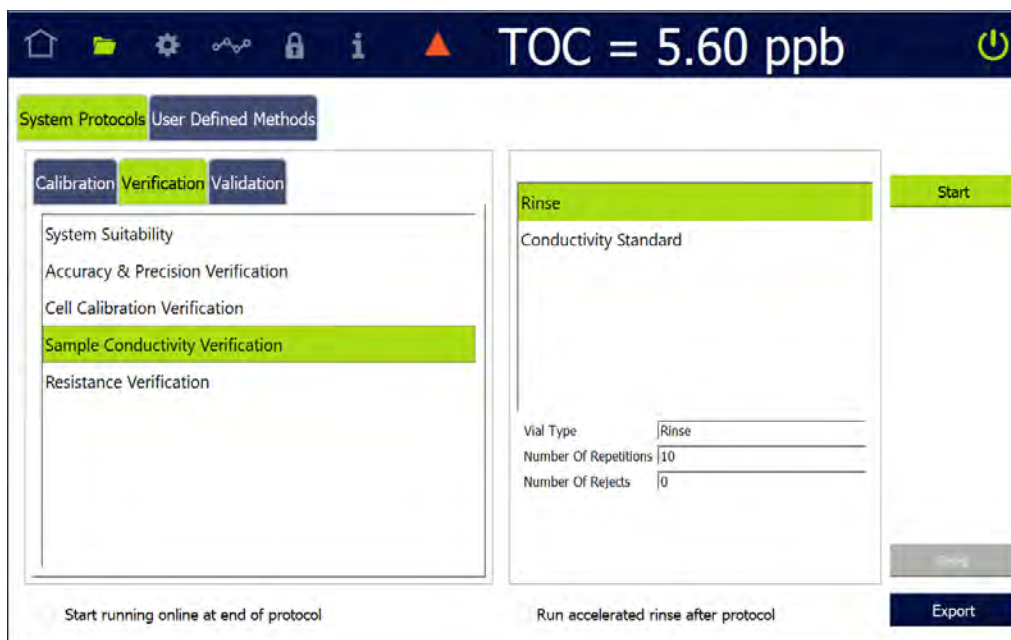

5.6 Select **Sample Conductivity Verification** and press **START**. A *Please specify the pass/fail limit...* dialog box appears.



NOTE: Each *pass/fail* and *conductivity standard* value is user-definable within the specified range.

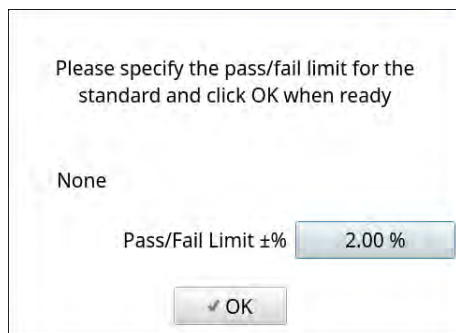

- 5.6.1 Leave the default value in the *Pass/Fail Limit ±%* field or press inside the field to use the numeric keypad to enter a new value and press **OK**. To run the protocol with no pass/fail limit, select the check box for *None*.
A *Please specify the Conductivity Standard value...* dialog box appears.

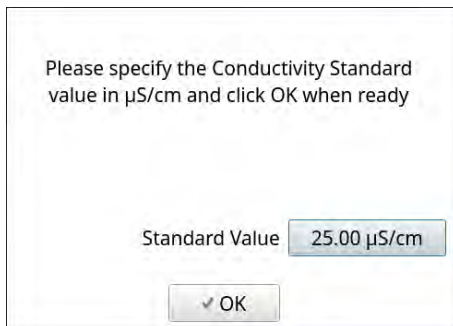

- 5.6.2 Leave the default value in the *Standard Value* field or press inside the field to use the numeric keypad to enter a new value and press **OK**.
- 5.7 If using a standard iOS System, go to step [5.9](#).
- 5.8 If using a Super iOS System, follow the prompts for the drain and rinse options (described in ["Super iOS Drain/Rinse" on page 228](#)).
- 5.8.1 A *Please insert...* dialog box appears.

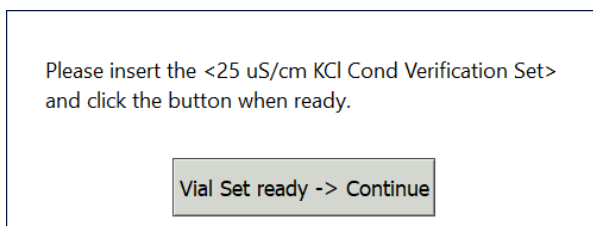

- 5.8.2 Insert the **25 μS/cm KCl Conductivity Verification Set** and press **VIAL SET READY-> CONTINUE**.
If using individual vials, **do not** insert them. Press **VIAL SET READY-> CONTINUE**. See ["Using Individual Vials in the Super iOS" on page 229](#) for more information.
- Port 2 = **Rinse**
 - Port 3 = **25 μS/cm Cond**
- 5.8.3 When analysis of the vial set is complete, remove it from the Super iOS. If a *Rinse After...* option was selected, follow the on-screen prompts for rinsing.
- 5.8.4 Go to step [5.10](#).



5.9 If using a standard iOS System:

5.9.1 A *Please insert the Rinse vial...* dialog box appears.

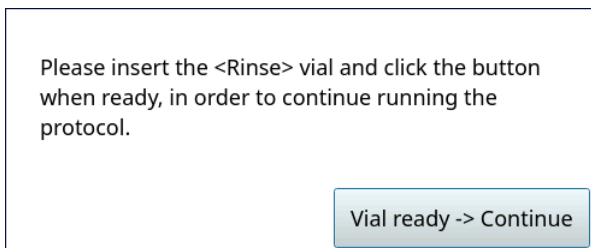

5.9.2 Open the door to the iOS System and wait 30 seconds for water to drain.

5.9.3 Insert the **Rinse** vial into the iOS System and press **VIAL READY-> CONTINUE**.

5.9.4 When processing of the **Rinse** vial is complete, a *Please insert the 25 µS/cm (or other selected standard) vial...* dialog box appears.

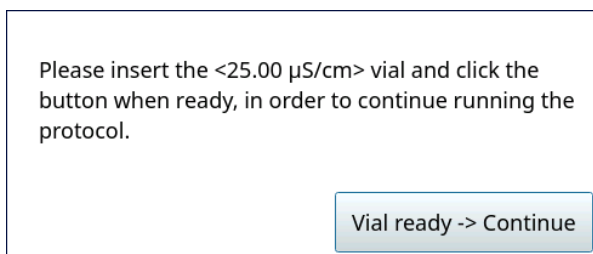

5.9.5 Remove the **Rinse** vial, then insert the **25 µS/cm (or other selected standard)** vial into the iOS System and press **VIAL READY-> CONTINUE**. The Analyzer begins analysis of the vial.

5.9.6 When analysis of the vial is complete, remove it from the iOS and press **VIAL REMOVED -> CONTINUE**.

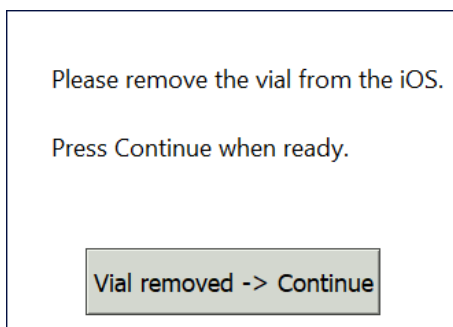

5.10 The *Sample Conductivity Verification: Protocol Complete* screen appears with the *Summary* tab active and multiple tabs available for reviewing, as follows:

	Value	Limit	Result
Conductivity % Difference	-94.2 %	± 2.00 %	Failed
Conductivity RSD	0.00 %	≤ 1.00 %	Passed

- Vial 1 — Select this tab to view analysis details for the *Rw Blank* standard, as needed.
- Vial 2 — Select this tab to view analysis details for the *500 ppb* standard, as needed
- Summary — Select this tab to view the summary of analysis, including a *passed* or *failed* result. It also contains the **APPLY** and **REJECT** buttons, as well as the **PRINT** and **EXPORT** buttons.

5.11 Referencing the *Summary* tab, record the results data on the *Sample Conductivity Verification Worksheet*.

5.12 If the verification *failed*, leave the screen as is and contact Technical Support or your local service provider. Before calling, e-mail the backup and system settings files (created in advance of running calibration protocols). After analysis of the data, you may be advised to accept the results or to pursue additional troubleshooting steps.

5.13 To print or export the results, press the corresponding button.

Resistance Verification Protocol

1.0 INTRODUCTION

Perform the following Resistance Verification Protocol to verify the resistance measurement capability of a Sievers M500 TOC Analyzer.

2.0 SCOPE

This procedure applies to the Sievers M500 TOC Analyzer.

3.0 MATERIALS

- 3.1 Sievers M500 TOC Analyzer
- 3.2 *Resistance Verification Worksheet*
- 3.3 10 MΩ Verification Resistor (supplied with Analyzer)

4.0 DEFINITIONS

- 4.1 NONE

5.0 PROCEDURE

- 5.1 *(OPTIONAL)* If DataGuard is enabled, log in to the Analyzer with a User ID and the appropriate password.
- 5.2 If the Analyzer is taking measurements, press **STOP ANALYSIS** .

Chapter 6 CALIBRATION AND SYSTEM PROTOCOLS

5.3 On the *System Protocols* screen, select the *Verification* tab.

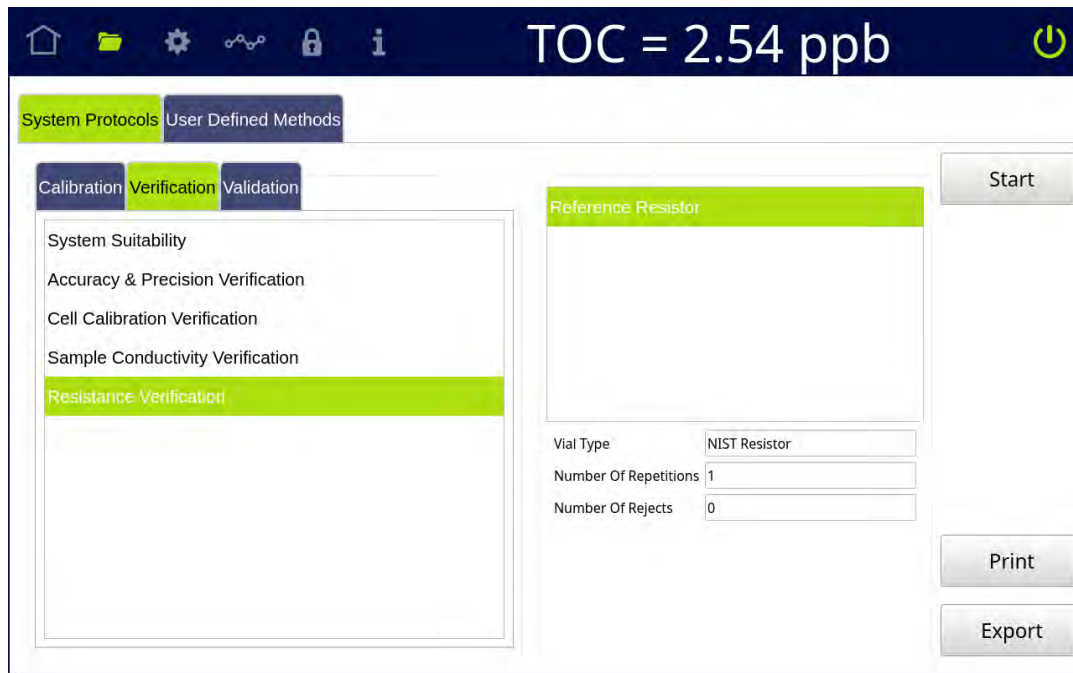

5.4 Select **Resistance** and press **START**. A *Please specify the Resistor value...* screen appears.

 **NOTE:** The Resistor value is user-definable within the specified range.

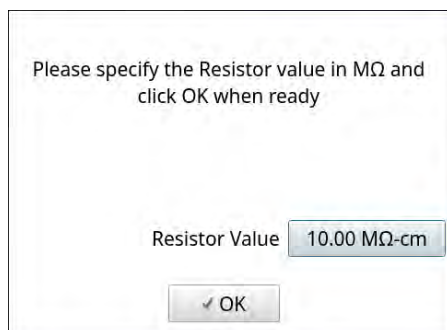

5.5 Leave the default value in the *Resistor Value* field or press inside the field to use the numeric keypad to enter a new value and press **OK**.

- 5.6 After measurement of the resistor is complete, the *Resistance Verification: Protocol Complete* screen appears with the *Summary* tab active.

Vial 1 Summary

Resistance Verification: Protocol Complete

	Value	Limit	Result
Cell Constant	1.0110	N/A	N/A
Theoretical Response	0.101 μ S/cm	N/A	N/A
Measured Response	0.101 μ S/cm	N/A	N/A
Resistance Error	0.000 μ S/cm	\pm 0.100 μ S/cm	Passed

Print Export Close

- Vial 1 — Because no vial is used in the Resistance Verification protocol, this tab is blank.
 - Summary — Select this tab to view the summary of analysis, including a *passed* or *failed* result. It also contains the **PRINT**, **EXPORT**, and **CLOSE** buttons.
- 5.7 Referencing the *Summary* tab, record the results data on the *Resistance Verification Worksheet*.
- 5.8 If the verification *failed*, leave the screen as is and contact Technical Support or your local service provider. Before calling, e-mail the backup and system settings files (created in advance of running calibration protocols). After analysis of the data, you may be advised to accept the results or to pursue additional troubleshooting steps.
- 5.9 To print or export the results, press the corresponding button.

TOC Linearity Protocol

1.0 INTRODUCTION

Perform this protocol to verify the linearity of a Sievers M500 TOC Analyzer. This protocol also determines the Analyzer's Limit of Detection (LOD) and Limit of Quantitation (LOQ).

2.0 SCOPE

This procedure applies to the Sievers M500 TOC Analyzer. The instrument should be calibrated and the analyst performing this protocol should be familiar with the terminology and operation of the Analyzer.

In addition to Linearity, this protocol determines the LOD and the LOQ for the Sievers M500 TOC Analyzer. SUEZ has predetermined the LOD of 0.03 ppb using highly stable, low-TOC water under controlled conditions. This procedure is not intended to verify this value; for additional information on this LOD evaluation, contact SUEZ or your local service provider.

Two LOD/LOQ METHODOLOGIES

SUEZ provides two methods for estimating the LOD/LOQ as part of the TOC Linearity Protocol: Extrapolation and Repetitive Measurements. You can also choose to determine LOD/LOQ using the Online TOC LOD/LOQ protocol found on page 326.

- *Extrapolation Methodology* — This method involves measuring a set of standards and projecting the standard deviation of those measurements through the y-intercept to allow an estimation of the standard deviation at zero analyte concentration.
- *Repetitive Measurements Methodology* — This method involves taking repeated measurements of the Rw Blank and calculating the standard deviation of the measurements. the LOD is estimated as three times the standard deviation of this result.



3.0 MATERIALS



NOTE: Use *only* Sievers standards purchased from SUEZ.

- 3.1 Sievers M500 TOC Analyzer
- 3.2 TOC Linearity Protocol Worksheet

For 3-point protocols:

- 3.3 3-point Linearity Standard Set:
 - 3.3.1 One vial — Rw Blank
 - 3.3.2 One vial — 250 ppb TOC
 - 3.3.3 One vial — 500 ppb TOC
 - 3.3.4 One vial — 750 ppb TOC



For 5-point protocols, add:

- 3.4 5-Point Linearity Set:
 - 3.4.1 One vial — Rw Blank
 - 3.4.2 One vial — 250 ppb TOC
 - 3.4.3 One vial — 500 ppb TOC
 - 3.4.4 One vial — 750 ppb TOC
 - 3.4.5 One vial — 1 ppm TOC
 - 3.4.6 One vial — 1.25 ppm TOC
- 3.5 (**OPTIONAL WHEN USING THE SUPER IOS**) SUEZ recommends the Flush Set for rinsing before, after, **or** before and after running the protocol.

4.0 DEFINITIONS

- 4.1 NONE

5.0 PROCEDURE

- 5.1 **(OPTIONAL)** If DataGuard is enabled, log in to the Analyzer with a User ID and the appropriate password.
- 5.2 If the Analyzer is taking measurements, press **STOP ANALYSIS** .
- 5.3 On the *System Protocols*  screen, select the *Validation* tab.

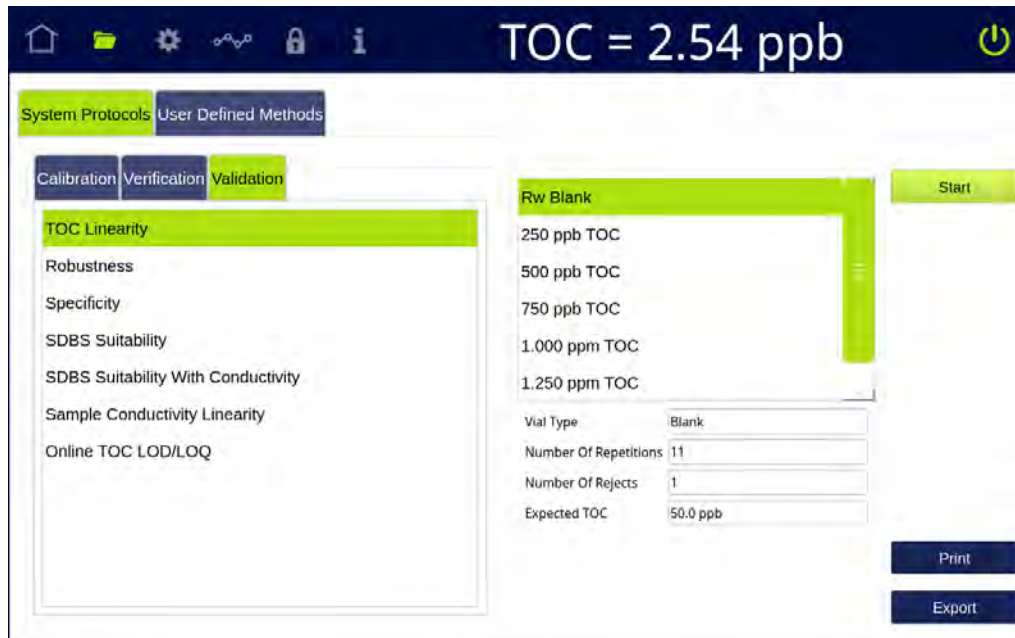

- 5.4 Select **TOC Linearity**, then press **START**.
 - 5.4.1 A *Number of Standards / LOD/LOQ Selection* dialog box appears.

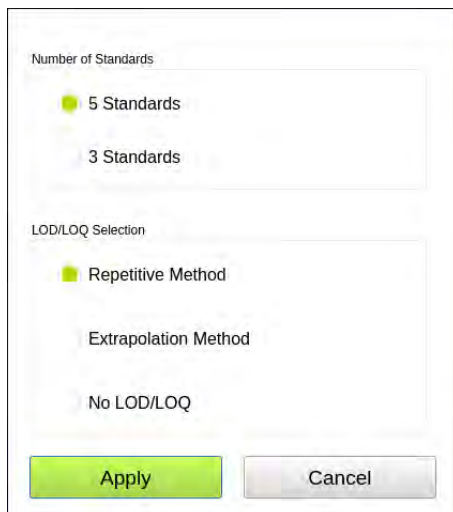



- 5.4.2 Select the appropriate number of standards to run for the validation (either 5 or 3) and the LOD/LOQ Method (repetitive, extrapolation, or No LOD/LOQ).
- 5.4.3 Press **APPLY** to continue.
- 5.5 If using a Super iOS System, follow the prompts for the drain and rinse options (described in ["Super iOS Drain/Rinse" on page 228](#)).
- 5.5.1 **If running a 5-point protocol**, go to step [5.5.5](#).
- 5.5.2 **If running a 3-point protocol**, A *Please insert...* dialog box appears.

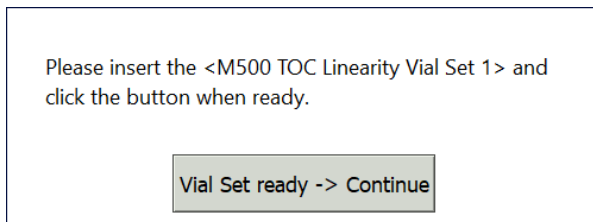

- 5.5.3 Insert **3-point Linearity Standard Set** and press **VIAL SET READY -> CONTINUE**. The Analyzer begins analysis of the vial set.
If using individual vials, **do not** insert them. Press **VIAL SET READY-> CONTINUE**. See ["Using Individual Vials in the Super iOS" on page 229](#) for more information.

- Port 1 = **Rw Blank**
- Port 2 = **250 ppb TOC**
- Port 3 = **500 ppb TOC**
- Port 4 = **750 ppb TOC**

- 5.5.4 When analysis of the vial set is complete, remove it from the iOS and go to step [5.7](#).
- 5.5.5 **(If performing a 5-point TOC Linearity protocol)** A *Please insert the 5-Point Linearity Set (Cartridge 1 of 2)...* dialog box appears.



- 5.5.6 Insert **5-point Linearity Standard Set (Cartridge 1 of 2)** and press **VIAL SET READY -> CONTINUE**. The Analyzer begins analysis of the vial set.
If using individual vials, **do not** insert them. Press **VIAL SET READY-> CONTINUE**. See ["Using Individual Vials in the Super iOS" on page 229](#) for more information.

- Port 1 = **Rw Blank**
- Port 2 = **250 ppb TOC**
- Port 3 = **500 ppb TOC**
- Port 4 = **750 ppb TOC**

5.5.7 When analysis of the vial set is complete, a *Please insert the 5-Point Linearity Set (Cartridge 2 of 2)...* dialog box appears.

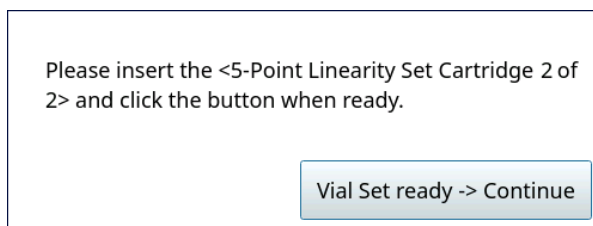

5.5.8 Remove **5-point Linearity Standard Set (Cartridge 1 of 2)**, then insert **5-point Linearity Standard Set (Cartridge 2 of 2)** and press **VIAL SET READY -> CONTINUE**. The Analyzer begins analysis of the vial set.

- Port 2 = **1 ppm TOC**
- Port 3 = **1.25 ppm TOC**

5.5.9 When analysis of the vial set is complete, remove it from the Super iOS. If a *Rinse After...* option was selected, follow the on-screen prompts for rinsing.

5.5.10 Go to step [5.7](#).

5.6 If using a standard iOS System:

5.6.1 A *Please insert...* dialog box appears.

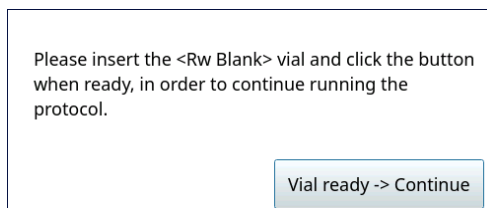

5.6.2 Open the door to the iOS System and wait 30 seconds for water to drain.

5.6.3 Insert the **Rw Blank** vial into the iOS System and press **VIAL READY-> CONTINUE**. The Analyzer begins analysis of the vial.



- 5.6.4 When analysis of the **Rw Blank** vial is complete, a *Please insert the 250 ppb TOC vial...* dialog box appears.

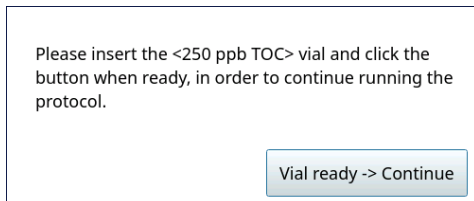

- 5.6.5 Remove the **Rw Blank** vial, then insert the **250 ppb TOC** vial into the iOS System and press **VIAL READY-> CONTINUE**. The Analyzer begins analysis of the vial.
- 5.6.6 When analysis of the **250 ppb TOC** vial is complete, a *Please insert the 500 ppb TOC vial...* dialog box appears.

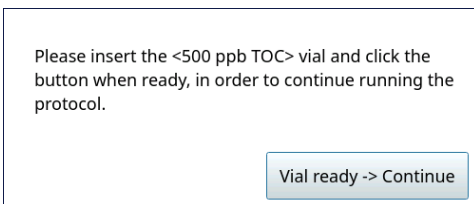

- 5.6.7 Remove the **250 ppb TOC** vial, then insert the **500 ppb TOC** vial into the iOS System and press **VIAL READY-> CONTINUE**. The Analyzer begins analysis of the vial.
- 5.6.8 When analysis of the **500 ppb TOC** vial is complete, a *Please insert the 750 ppb TOC vial...* dialog box appears.

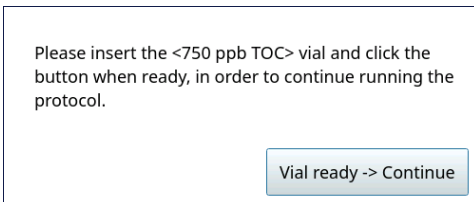

- 5.6.9 Remove the **500 ppb TOC** vial, then insert the **750 ppb TOC** vial into the iOS System and press **VIAL READY-> CONTINUE**. The Analyzer begins analysis of the vial.

5.6.10 When analysis of the 750 ppb TOC vial is complete:

5.6.10.1 *(If performing a 3-point TOC Linearity protocol)* Go to step [5.8](#).

5.6.10.2 *(If performing a 5-point TOC Linearity protocol)* A *Please insert the 1 ppm TOC vial...* dialog box appears.

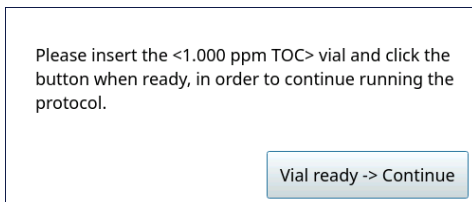

5.6.11 Remove the 750 ppb TOC vial, then insert the 1 ppm TOC vial into the iOS System and press **VIAL READY-> CONTINUE**. The Analyzer begins analysis of the vial.

5.6.12 When analysis of the 1 ppm TOC vial is complete, a *Please insert the 1.25 ppm TOC vial...* dialog box appears.

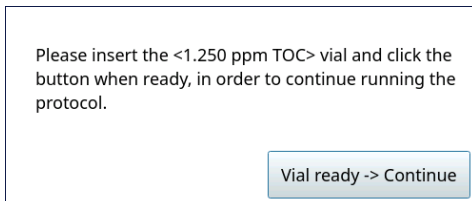

5.6.13 Remove the 1 ppm TOC vial, then insert the 1.25 ppm TOC vial into the iOS System and press **VIAL READY-> CONTINUE**. The Analyzer begins analysis of the vial.

5.6.14 When analysis of the vial is complete, remove it from the iOS and press **VIAL REMOVED -> CONTINUE**.

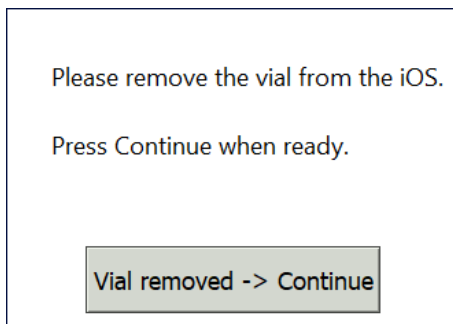

5.7 The *TOC Linearity: Protocol Complete* screen appears with the *Summary* tab active and multiple tabs available for review, as follows:

	Value	Limit	Result
Correlation Coefficient (R)	1.000	N/A	N/A
Square of Correlation Coefficient (R ²)	1.000	≥ 0.970	Passed
Regression Slope	1.002	N/A	N/A
Regression y-intercept	1.94 ppb	N/A	N/A
Residual Sum of Squares	178 ppb ²	N/A	N/A
Rw Blank Standard Deviation	0.78 ppb	N/A	N/A
LOD	2.57 ppb	N/A	N/A
LOQ	7.80 ppb	N/A	N/A

- Vial 1–4 (3-point protocol) or Vial 1–6 (5-point protocol) — Select these tabs to view analysis details for each standard, as needed.
- Summary — Select this tab to view the summary of analysis, including a *passed* or *failed* result. It also contains **PRINT**, **EXPORT**, and **CLOSE** buttons.
- The **LINEARITY PLOT** button shows a graph of TOC linear regression.

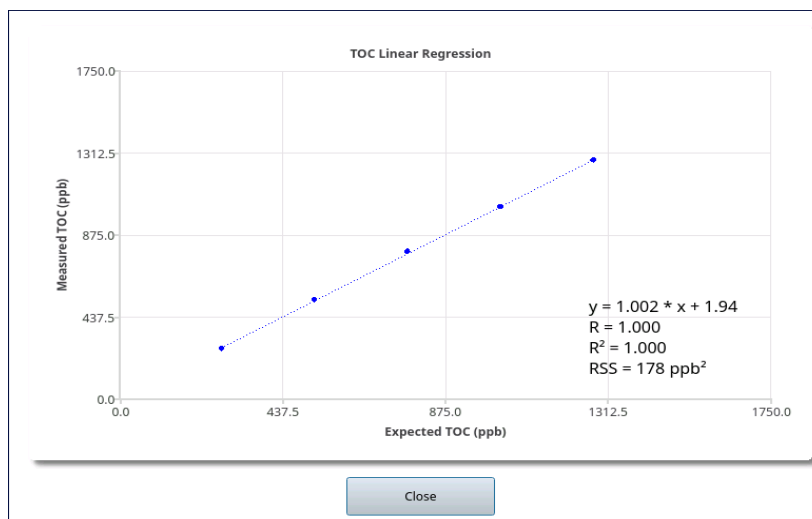

5.8 Referencing the *Summary* tab, record the results data on the *Linearity Protocol Worksheet*.

5.9 To print or export the results, press the corresponding button.

Robustness Verification Protocol

1.0 INTRODUCTION

Perform this protocol to verify the robustness of a Sievers M500 TOC Analyzer.

2.0 SCOPE

This procedure applies to the Sievers M500 TOC Analyzer. The instrument should be calibrated and the analyst performing this protocol should be familiar with the terminology and operation of the Analyzer.

3.0 MATERIALS





NOTE: Use *only* Sievers standards purchased from SUEZ.

- 3.1 Sievers M500 TOC Analyzer
- 3.2 *Robustness Verification Protocol Worksheet*
- 3.3 **Robustness Set:**
 - 3.3.1 One vial — **Rw Blank**
 - 3.3.2 One vial — **500 ppb Rs**
 - 3.3.3 One vial — **500 ppb Rss**
- 3.4 (**OPTIONAL WHEN USING THE SUPER IOS**) SUEZ recommends the **Flush Set** for rinsing before, after, **or** before and after running the protocol.

4.0 DEFINITIONS

- 4.1 NONE

5.0 PROCEDURE

- 5.1 (**OPTIONAL**) If DataGuard is enabled, log in to the Analyzer with a User ID and the appropriate password.
- 5.2 If the Analyzer is taking measurements, press **STOP ANALYSIS** .
- 5.3 On the *System Protocols*  screen, select the *Validation* tab.

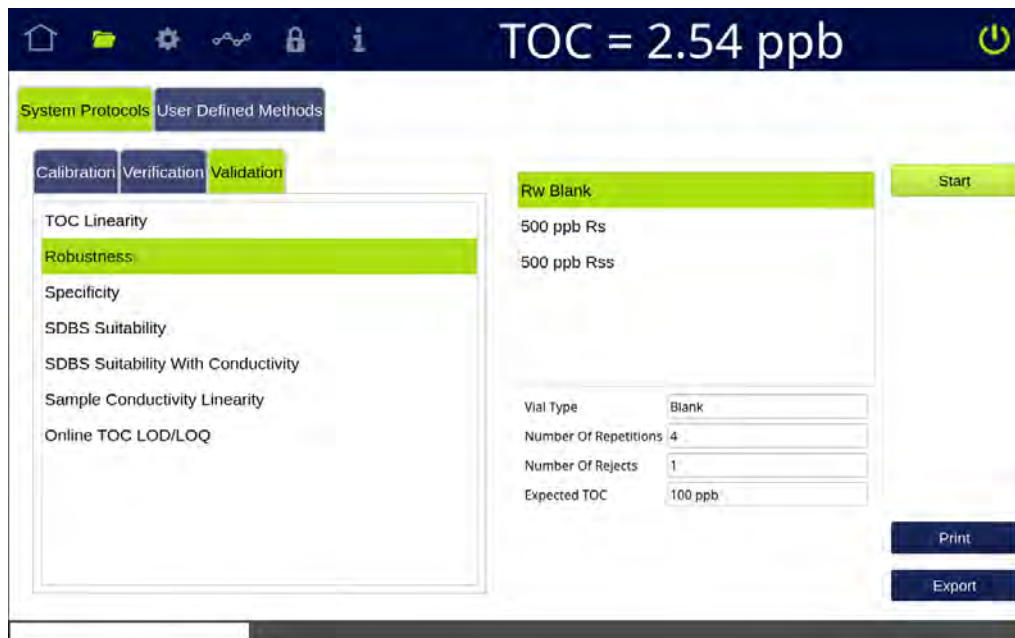

5.4 Select **Robustness**, then press **START**.

5.5 If using a standard iOS System, go to step [5.7](#).

5.6 If using a Super iOS System, follow the prompts for the drain and rinse options (described in ["Super iOS Drain/Rinse" on page 228](#)).

5.6.1 A *Please insert...* dialog box appears.

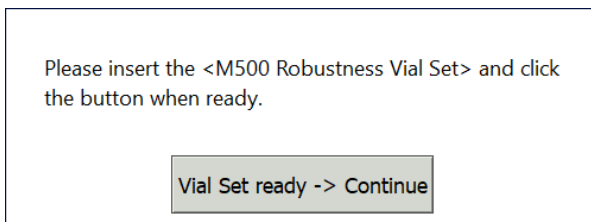

5.6.2 Insert the **Robustness Set** and press **VIAL SET READY -> CONTINUE**.

If using individual vials, **do not** insert them. Press **VIAL SET READY-> CONTINUE**. See ["Using Individual Vials in the Super iOS" on page 229](#) for more information.

- Port 1 = **Rw Blank**
- Port 2 = **500 ppb Rs**
- Port 3 = **500 ppb Rss**

5.6.3 When analysis of the vial set is complete, remove it from the Super iOS. If a *Rinse After...* option was selected, follow the on-screen prompts for rinsing.

5.6.4 Go to step [5.8](#).

5.7 If using a standard iOS System:

5.7.1 A *Please insert...* dialog box appears.

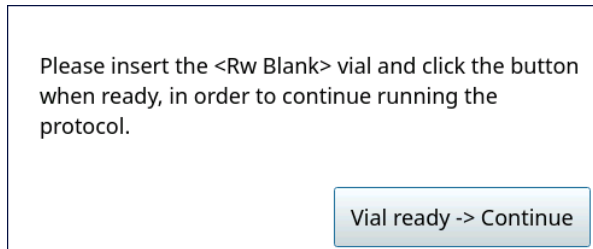

5.7.2 Open the door to the iOS System and wait 30 seconds for water to drain.

5.7.3 Insert the **Rw Blank** vial into the iOS System and press **VIAL READY-> CONTINUE**. The Analyzer begins analysis of the vial.

5.7.4 When analysis of the **Rw Blank** vial is complete, a *Please insert the 500 ppb Rs vial...* dialog box appears.

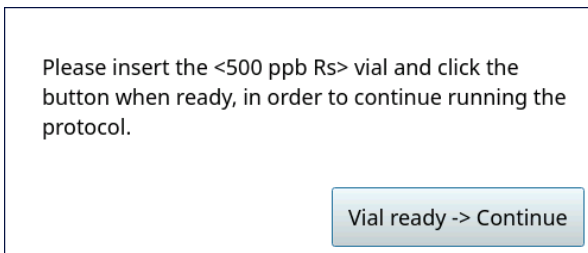

5.7.5 Remove the **Rw Blank** vial, then insert the **500 ppb Rs** vial into the iOS System and press **VIAL READY-> CONTINUE**. The Analyzer begins analysis of the vial.

5.7.6 When analysis of the **500 ppb Rs** vial is complete, a *Please insert the 500 ppb Rss vial...* dialog box appears.

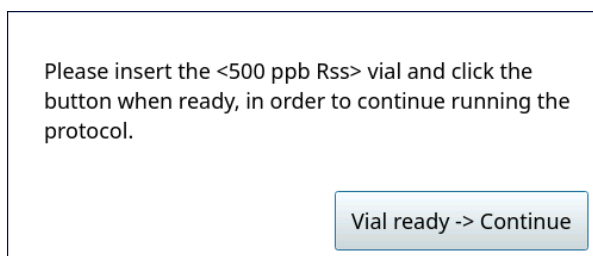

5.7.7 Remove the **500 ppb Rs** vial, then insert the **500 ppb Rss** vial into the iOS System and press **VIAL READY-> CONTINUE**. The Analyzer begins analysis of the vial.



5.7.8 When analysis of the vial is complete, remove it from the iOS and press **VIAL REMOVED -> CONTINUE**.

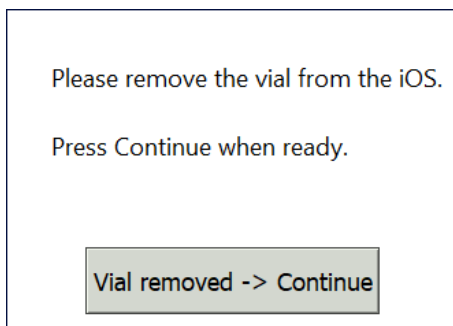

5.8 The *Robustness: Protocol Complete* screen appears with the *Summary* tab active and multiple tabs available for review, as follows:

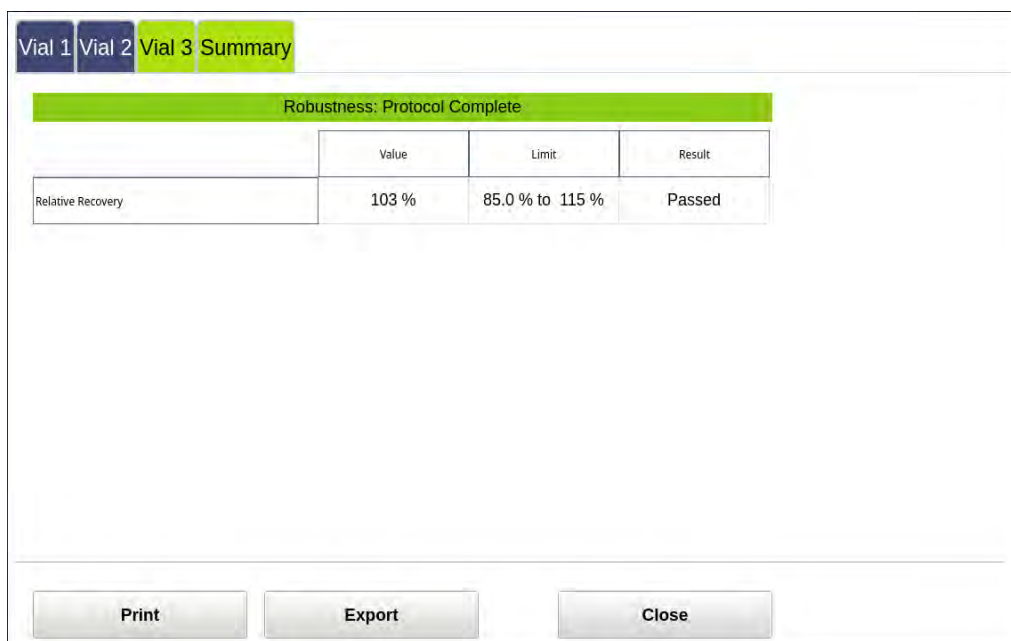

- Vial 1–3 — Select these tabs to view analysis details for each standard, as needed.
- Summary — Select this tab to view the summary of analysis, including a *passed* or *failed* result. It also contains **PRINT**, **EXPORT**, and **CLOSE** buttons.

5.9 Referencing the *Summary* tab, record the results data on the *Robustness Protocol Worksheet*.

5.10 To print or export the results, press the corresponding button.

Specificity Verification Protocol

1.0 INTRODUCTION

Perform this protocol to verify the specificity of a Sievers M500 TOC Analyzer.

2.0 SCOPE

This procedure applies to the Sievers M500 TOC Analyzer. The instrument should be calibrated and the analyst performing this protocol should be familiar with the terminology and operation of the Analyzer.

3.0 MATERIALS



NOTE: Use *only* Sievers standards purchased from SUEZ.

- 3.1 Sievers M500 TOC Analyzer
- 3.2 *Specificity Verification Protocol Worksheet*
- 3.3 **Specificity Set:**
 - 3.3.1 One vial — **Rw Blank**
 - 3.3.2 One vial — **500 ppb MeOH**
 - 3.3.3 One vial — **500 ppb Nic**
 - 3.3.4 One vial — **500 ppb TOC**
- 3.4 (**OPTIONAL WHEN USING THE SUPER IOS**) SUEZ recommends the **Flush Set** for rinsing before, after, **or** before and after running the protocol.

4.0 DEFINITIONS

- 4.1 NONE

5.0 PROCEDURE

- 5.1 (**OPTIONAL**) If DataGuard is enabled, log in to the Analyzer with a User ID and the appropriate password.
- 5.2 If the Analyzer is taking measurements, press **STOP ANALYSIS** .

5.3 On the *System Protocols* screen, select the *Validation* tab.

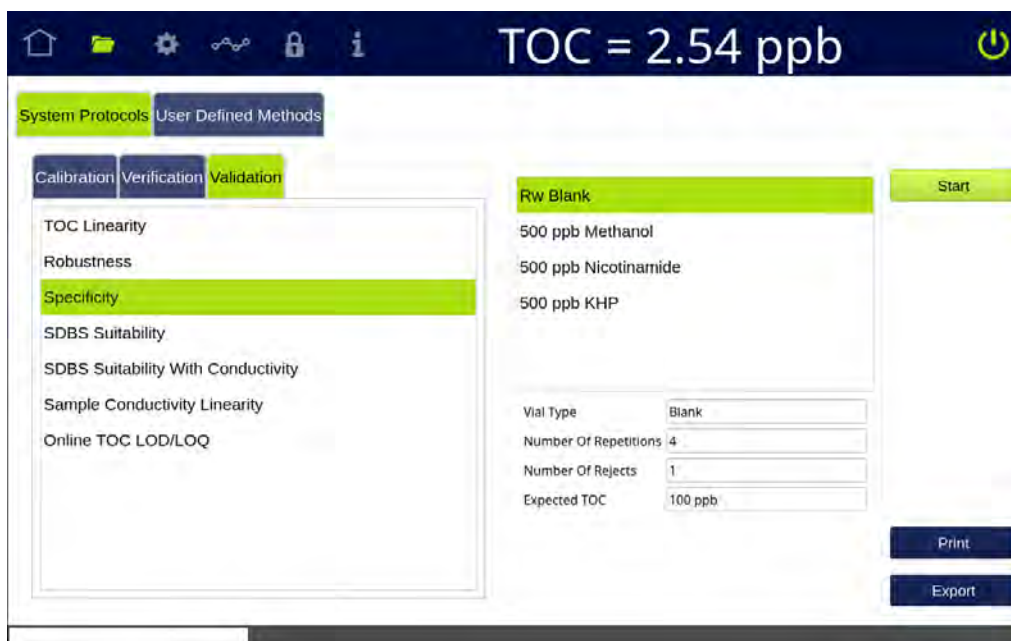

5.4 Select **Specificity**, then press **START**.

5.5 If using a standard iOS System, go to step [5.7](#).

5.6 If using a Super iOS System, follow the prompts for the drain and rinse options (described in ["Super iOS Drain/Rinse" on page 228](#)).

5.6.1 A *Please insert...* dialog box appears.

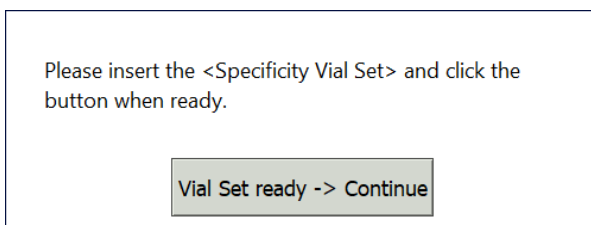

5.6.2 Insert the **Specificity Set** and press **VIAL SET READY -> CONTINUE**. The Analyzer begins analysis of the vial set.

If using individual vials, **do not** insert them. Press **VIAL SET READY-> CONTINUE**. See ["Using Individual Vials in the Super iOS" on page 229](#) for more information.

- Port 1 = **Rw Blank**
- Port 2 = **500 ppb MeOH**
- Port 3 = **500 ppb Nic**
- Port 4 = **500 ppb TOC**

- 5.6.3 When analysis of the vial set is complete, remove it from the Super iOS. If a *Rinse After...* option was selected, follow the on-screen prompts for rinsing.
- 5.6.4 Go to step [5.8](#).
- 5.7 If using a standard iOS System:
- 5.7.1 A *Please insert...* dialog box appears.

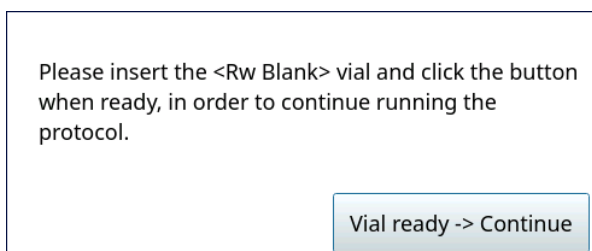

- 5.7.2 Open the door to the iOS System and wait 30 seconds for water to drain.
- 5.7.3 Insert the **Rw Blank** vial into the iOS System and press **VIAL READY-> CONTINUE**. The Analyzer begins analysis of the vial.
- 5.7.4 When analysis of the **Rw Blank** vial is complete, a *Please insert the 500 ppb MeOH vial...* dialog box appears.

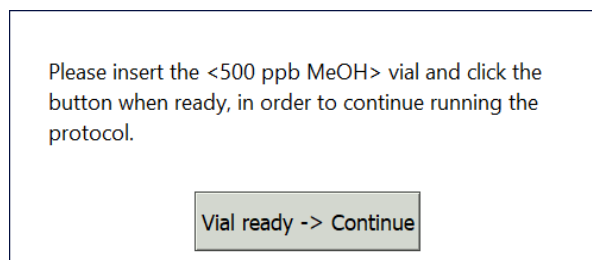

- 5.7.5 Remove the **Rw Blank** vial, then insert the **500 ppb MeOH** vial into the iOS System and press **VIAL READY-> CONTINUE**. The Analyzer begins analysis of the vial.
- 5.7.6 When analysis of the **500 ppb MeOH** vial is complete, a *Please insert the 500 ppb Nic vial...* dialog box appears.

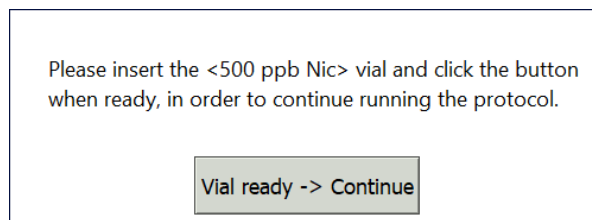

- 5.7.7 Remove the **500 ppb MeOH** vial, then insert the **500 ppb Nic** vial into the iOS System and press **VIAL READY-> CONTINUE**. The Analyzer begins analysis of the vial.



5.7.8 When analysis of the 500 ppb Nic vial is complete, a *Please insert the 500 ppb TOC vial...* dialog box appears.

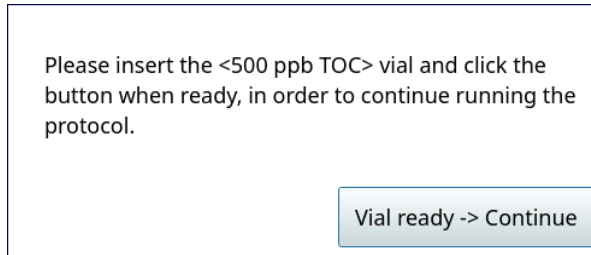

5.7.9 Remove the 500 ppb Nic vial, then insert the 500 ppb TOC vial into the iOS System and press **VIAL READY-> CONTINUE**. The Analyzer begins analysis of the vial.

5.7.10 When analysis of the vial is complete, remove it from the iOS and press **VIAL REMOVED -> CONTINUE**.

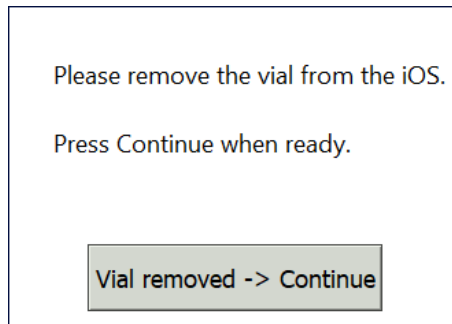

5.8 The *Specificity: Protocol Complete* screen appears with the *Summary* tab active and multiple tabs available for review, as follows:

The screenshot shows a software interface with five tabs at the top: 'Vial 1', 'Vial 2', 'Vial 3', 'Vial 4', and 'Summary'. The 'Summary' tab is selected and highlighted in green. Below the tabs is a header bar with the text 'Specificity: Protocol Complete'. Underneath is a table with three columns: 'Value', 'Limit', and 'Result'. The table contains three rows of data. At the bottom of the screen are three buttons: 'Print', 'Export', and 'Close'.

	Value	Limit	Result
Methanol Recovery	101 %	85.0 % to 115 %	Passed
Nicotinamide Recovery	99.0 %	85.0 % to 115 %	Passed
KHP Recovery	101 %	85.0 % to 115 %	Passed

- Vial 1–4 — Select these tabs to view analysis details for each standard, as needed.
- Summary — Select this tab to view the summary of analysis, including a *passed* or *failed* result. It also contains **PRINT**, **EXPORT**, and **CLOSE** buttons.

5.9 Referencing the *Summary* tab, record the results data on the *Specificity Protocol Worksheet*.

5.10 To print or export the results, press the corresponding button.

SDBS Suitability Protocol

1.0 INTRODUCTION

Perform this protocol to verify that the Sievers M500 TOC Analyzer can recover SDBS. This protocol also verifies that the Analyzer meets the testing requirements outlined by the Japanese Pharmacopeia (JP) monographs; JP <2.59> Total Organic Carbon (TOC) for Water Injection and Purified Water.

2.0 SCOPE

This procedure applies to the Sievers M500 TOC Analyzer. The instrument should be calibrated and the analyst performing this protocol should be familiar with the terminology and operation of the Analyzer.

3.0 MATERIALS



NOTE: Use **only** Sievers standards purchased from SUEZ.

- 3.1 Sievers M500 TOC Analyzer
- 3.2 SDBS Suitability Protocol Worksheet
- 3.3 SDBS Suitability Standard Set (TOC Only):
 - 3.3.1 One vial — **Rw Blank**
 - 3.3.2 One vial — **500 ppb TOC**
 - 3.3.3 (**OPTIONAL WHEN USING THE SUPER IOS**) SUEZ recommends the **Flush Set** for rinsing before, after, **or** before and after running the protocol.

4.0 DEFINITIONS

- 4.1 JP — JAPANESE PHARMACOPEIA
- 4.2 SDBS — SODIUM DODECYLBENZENESULFONATE

5.0 PROCEDURE

- 5.1 (**OPTIONAL**) If DataGuard is enabled, log in to the Analyzer with a User ID and the appropriate password.
- 5.2 If the Analyzer is taking measurements, press **STOP ANALYSIS** .

5.3 On the *System Protocols* screen, select the *Validation* tab.

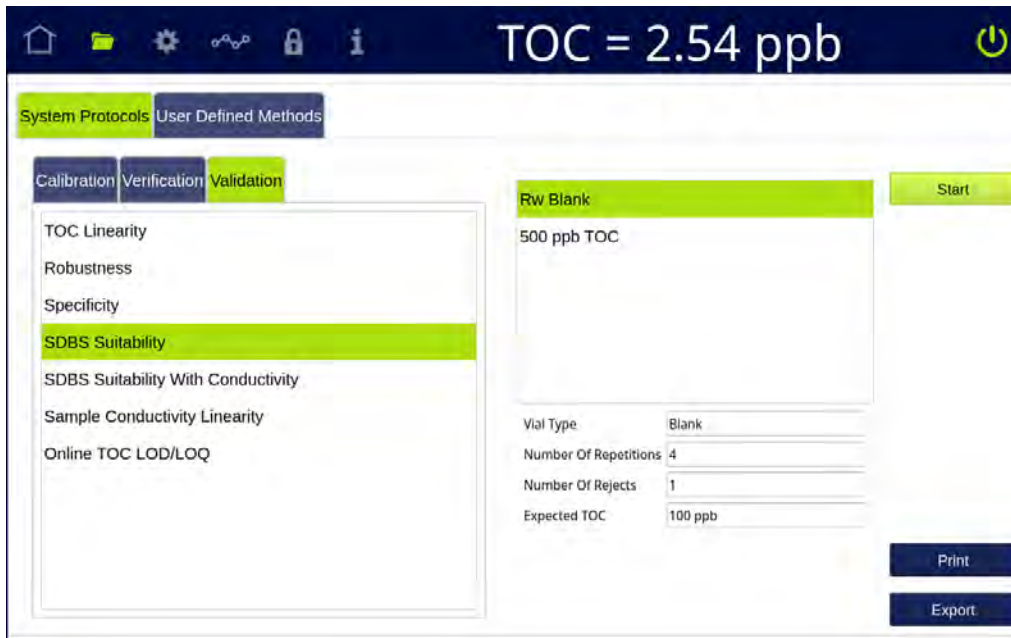

5.4 Select **SDBS Suitability**, then press **START**.

5.5 If using a standard iOS System, go to step [5.7](#).

5.6 If using a Super iOS System, follow the prompts for the drain and rinse options (described in ["Super iOS Drain/Rinse" on page 228](#)).

5.6.1 A *Please insert the SDBS Suitability Standard Set (TOC Only)...* dialog box appears.

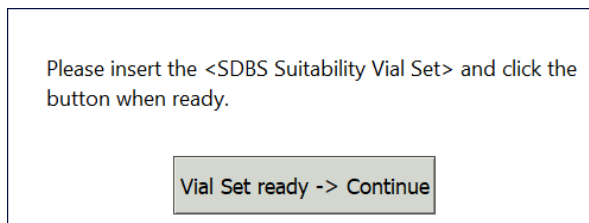

5.6.2 Insert the **SDBS Suitability Standard Set (TOC Only)** and press **VIAL SET READY -> CONTINUE**.

If using individual vials, **do not** insert them. Press **VIAL SET READY-> CONTINUE**. See ["Using Individual Vials in the Super iOS" on page 229](#) for more information.

- Port 2 = **Rw Blank**
- Port 3 = **500 ppb TOC**



- 5.6.3 When analysis of the vial set is complete, remove it from the Super iOS. If a *Rinse After...* option was selected, follow the on-screen prompts for rinsing.
- 5.6.4 Go to step [5.8](#).
- 5.7 If using a standard iOS System:
- 5.7.1 A *Please insert the Rw Blank vial...* dialog box appears.

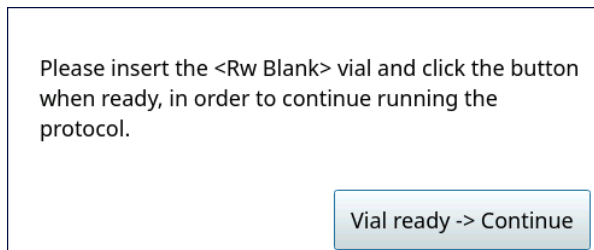

- 5.7.2 Open the door to the iOS System and wait 30 seconds for water to drain.
- 5.7.3 Insert the **Rw Blank** vial into the iOS System and press **VIAL READY-> CONTINUE**. The Analyzer begins analysis of the vial.
- 5.7.4 When analysis of the **Rw Blank** vial is complete, a *Please insert the 500 ppb TOC vial...* dialog box appears.

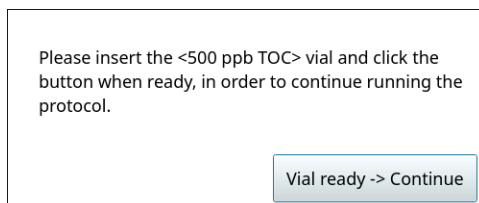

- 5.7.5 Remove the **Rw Blank** vial, then insert the **500 ppb TOC** vial into the iOS System and press **VIAL READY-> CONTINUE**. The Analyzer begins analysis of the vial.
- 5.7.6 When analysis of the vial is complete, remove it from the iOS and press **VIAL REMOVED -> CONTINUE**.

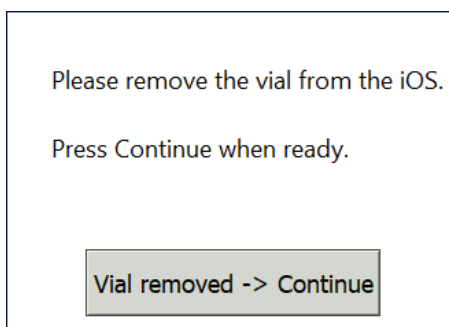

5.8 The *SDBS Suitability: Protocol Complete* screen appears with the *Summary* tab active and multiple tabs available for review, as follows:

	Value	Limit	Result
Rw Blank TOC	22.5 ppb	≤ 250 ppb	Passed
500 ppb TOC Blank Corrected	516 ppb	≥ 450 ppb	Passed

- Vial 1–2 — Select these tabs to view analysis details for each standard, as needed.
- Summary — Select this tab to view the summary of analysis, including a *passed* or *failed* result. It also contains **PRINT**, **EXPORT**, and **CLOSE** buttons.

5.9 Referencing the *Summary* tab, record the results data on the *SDBS Suitability Protocol Worksheet*.

5.10 To print or export the results, press the corresponding button.



SDBS Suitability With Conductivity Protocol

1.0 INTRODUCTION

Perform this protocol to verify that the Sievers M500 TOC Analyzer can recover SDBS and KCl. This protocol also verifies that the Analyzer meets the testing requirements outlined by the Japanese Pharmacopeia (JP) monographs; JP <2.59> Total Organic Carbon (TOC) for Water Injection and Purified Water and JP <2.51> Conductivity (COND).

2.0 SCOPE

This procedure applies to the Sievers M500 TOC Analyzer. The instrument should be calibrated and the analyst performing this protocol should be familiar with the terminology and operation of the Analyzer.

3.0 MATERIALS



NOTE: Use *only* Sievers standards purchased from SUEZ. However, for this protocol the KCl standard must be prepared by the customer according to the Japanese Pharmacopeia.

- 3.1 Sievers M500 TOC Analyzer
- 3.2 SDBS Suitability with Conductivity Protocol Worksheet
- 3.3 SDBS Suitability Standard Set:
 - 3.3.1 One vial — Rw Blank
 - 3.3.2 One vial — 500 ppb TOC
 - 3.3.3 One vial — 133 μ S/cm Cond
 - 3.3.4 (**OPTIONAL WHEN USING THE SUPER IOS**) SUEZ recommends the Flush Set for rinsing before, after, **or** before and after running the protocol.

4.0 DEFINITIONS

- 4.1 JP — JAPANESE PHARMACOPEIA
- 4.2 SDBS — SODIUM DODECYLBENZENESULFONATE

5.0 PROCEDURE

- 5.1 (**OPTIONAL**) If DataGuard is enabled, log in to the Analyzer with a User ID and the appropriate password.
- 5.2 If the Analyzer is taking measurements, press **STOP ANALYSIS** .

Chapter 6 CALIBRATION AND SYSTEM PROTOCOLS

5.3 On the *System Protocols* screen, select the *Validation* tab.

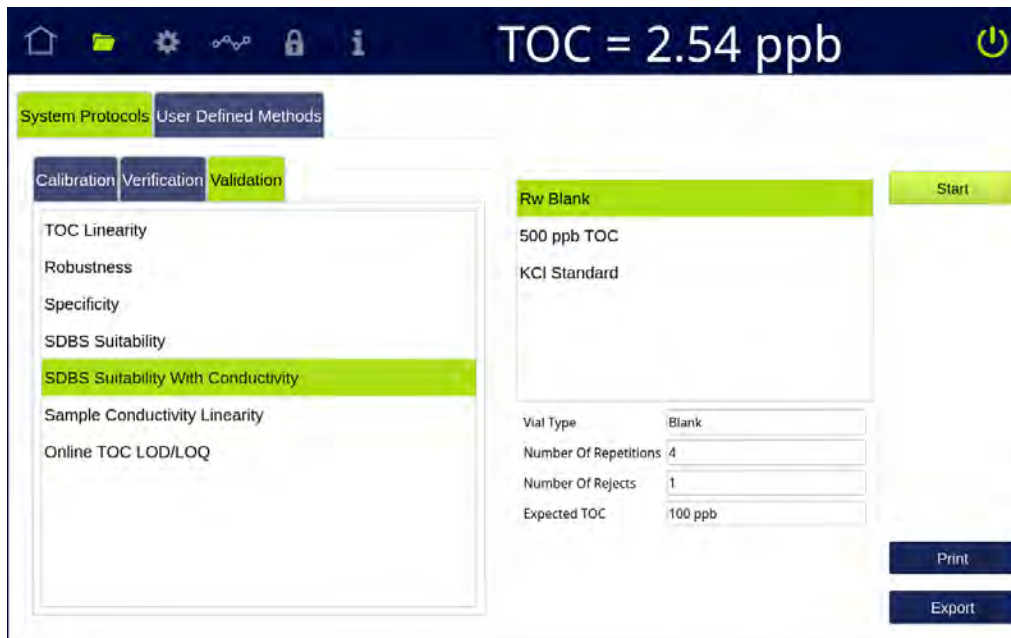

5.4 Select **SDBS Suitability With Conductivity**, then press **Start**.

5.4.1 The Analyzer reads the sample cell temperature.

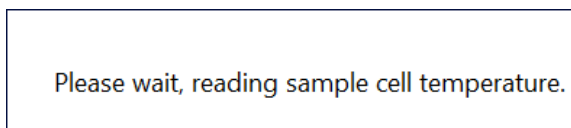

5.4.2 If the sample cell temperature is out of range, press **YES** to continue the protocol, or **NO** to cancel.

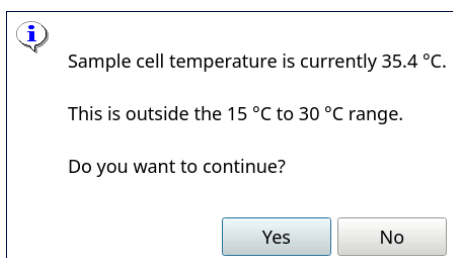

5.5 If using a standard iOS System, go to step [5.7](#).

5.6 If using a Super iOS System, follow the prompts for the drain and rinse options (described in ["Super iOS Drain/Rinse" on page 228](#)).



5.6.1 A *Please insert...* dialog box appears.

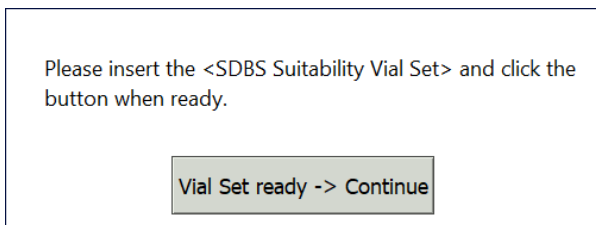

5.6.2 Insert the **SDBS Suitability Standard Set** (TOC Only) and press **VIAL SET READY -> CONTINUE**, then go to step [5.6.6](#).

If using individual vials, **do not** insert them. Press **VIAL SET READY-> CONTINUE**. See ["Using Individual Vials in the Super iOS" on page 229](#) for more information.

- Port 2 = **Rw Blank**
- Port 3 = **500 ppb TOC**

5.6.3 **(Individual vials only)** A *Please select the conductivity...* dialog box appears.



NOTE: The conductivity standard value is user-definable within the specified range.

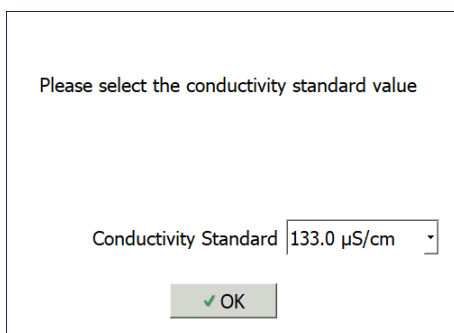

5.6.4 Leave the default value in the *Conductivity Standard* field or press inside the field to choose from two conductivity standards.

5.6.5 Select a conductivity standard value from the menu:

- 133 µS/cm (default)
- 26.60 µS/cm

If using the default value, press **OK** to proceed.

If changing from the default, select the standard value, press **OK** to confirm the choice, then press **OK** again to proceed.

5.6.6 When analysis of the vial set is complete, a *Please remove...* dialog box appears.

Please remove the <SDBS Suitability Vial Set> and insert your conductivity standard vial in position 4.

Click the button when ready.

Vial Ready -> Continue

5.6.7 Remove the **SDBS Suitability Standard Set**, then insert the conductivity standard and press **VIAL SET READY -> CONTINUE**.

- Port 4 = **133 μ S/cm Cond** (or **26 μ S/cm Cond**)

5.6.8 When analysis of the vial set is complete, remove it from the Super iOS. If a *Rinse After...* option was selected, follow the on-screen prompts for rinsing.

5.6.9 Go to step [5.8](#).

5.7 If using a standard iOS System:

5.7.1 A *Please select the conductivity...* dialog box appears.



NOTE: The conductivity standard value is user-definable within the specified range.

Please select the conductivity standard value

Conductivity Standard 133.0 μ S/cm

OK

5.7.2 Leave the default value in the *Conductivity Standard* field or press inside the field to choose from two conductivity standards.

5.7.3 Select a conductivity standard value from the menu:

- 133 μ S/cm (default)
- 26.60 μ S/cm

If using the default value, press **OK** to proceed.

If changing from the default, select the standard value, press **OK** to confirm the choice, then press **OK** again to proceed.



5.7.4 A *Please insert the Rw Blank vial...* dialog box appears.

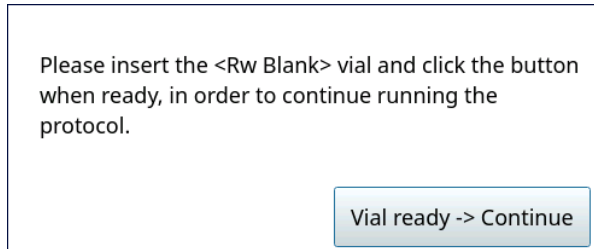

5.7.5 Open the door to the iOS System and wait 30 seconds for water to drain.

5.7.6 Insert the **Rw Blank** vial into the iOS System and press **VIAL READY-> CONTINUE**. The Analyzer begins analysis of the vial.

5.7.7 When analysis of the **Rw Blank** vial is complete, a *Please insert the 500 ppb TOC vial...* dialog box appears.

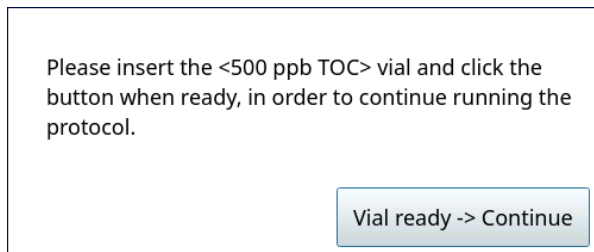

5.7.8 Remove the **Rw Blank** vial, then insert the **500 ppb TOC** vial into the iOS System and press **VIAL READY-> CONTINUE**. The Analyzer begins analysis of the vial.

5.7.9 When analysis of the **500 ppb TOC** vial is complete, a *Please insert the 133.0 µS/cm Standard vial...* dialog box appears.

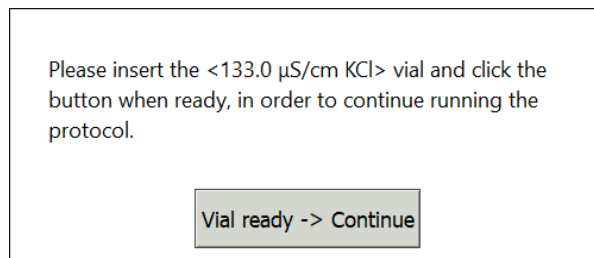

5.7.10 Remove the **500 ppb TOC** vial, then insert the **133.0 µS/cm Cond** (or **26.0µS/cm Cond**) vial into the iOS System and press **VIAL READY-> CONTINUE**. The Analyzer begins analysis of the vial.

5.7.11 When analysis of the vial is complete, remove it from the iOS and press **VIAL REMOVED -> CONTINUE**.

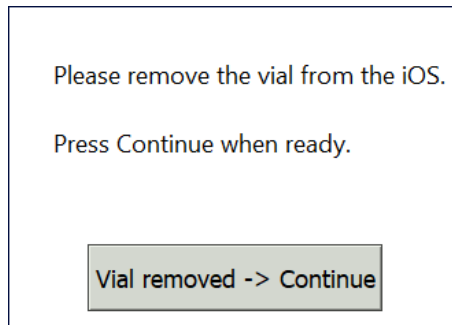

5.8 The *SDBS Suitability With Conductivity: Protocol Complete* screen appears with the *Summary* tab active and multiple tabs available for review, as follows:

SDBS Suitability With Conductivity: Protocol Complete			
	Value	Limit	Result
Rw Blank TOC	25.7 ppb	≤ 250 ppb	Passed
500 ppb TOC Blank Corrected	542 ppb	≥ 450 ppb	Passed
Sample Temperature	29.6 °C	15.0 °C to 30.0 °C	Passed
Conductivity % Difference	-1.45 %	± 5.00 %	Passed
Conductivity RSD	0.06 %	< 2.00 %	Passed

Print Export Close

- Vial 1–3 — Select these tabs to view analysis details for each standard, as needed.
- Summary — Select this tab to view the summary of analysis, including a *passed* or *failed* result. It also contains the **CLOSE** button, as well as the **PRINT** and **EXPORT** buttons.

5.9 Referencing the *Summary* tab, record the results data on the *SDBS Suitability With Conductivity Protocol Worksheet*.

5.10 To print or export the results, press the corresponding button.



Sample Conductivity Linearity Protocol

1.0 INTRODUCTION

Perform this protocol to verify the linearity of sample conductivity measurements from a Sievers M500 TOC Analyzer.

2.0 SCOPE

This procedure applies to the Sievers M500 TOC Analyzer. The instrument should be calibrated and the analyst performing this protocol should be familiar with the terminology and operation of the Analyzer.

3.0 MATERIALS



NOTE: Use *only* Sievers standards purchased from SUEZ.

- 3.1 Sievers M500 TOC Analyzer
- 3.2 *Sample Conductivity Linearity Protocol Worksheet*
- 3.3 **Conductivity Linearity Set:**
 - 3.3.1 One vial — 5 $\mu\text{S/cm}$ Cond
 - 3.3.2 One vial — 10 $\mu\text{S/cm}$ Cond
 - 3.3.3 One vial — 25 $\mu\text{S/cm}$ Cond
 - 3.3.4 One vial — 50 $\mu\text{S/cm}$ Cond
 - 3.3.5 One vial — 100 $\mu\text{S/cm}$ Cond
- 3.4 (**OPTIONAL WHEN USING THE SUPER IOS**) SUEZ recommends the **Flush Set** for rinsing before, after, **or** before and after running the protocol.

4.0 DEFINITIONS

- 4.1 NONE

5.0 PROCEDURE

- 5.1 (**OPTIONAL**) If DataGuard is enabled, log in to the Analyzer with a User ID and the appropriate password.
- 5.2 If the Analyzer is taking measurements, press **STOP ANALYSIS** .

5.3 On the *System Protocols* screen, select the *Validation* tab.

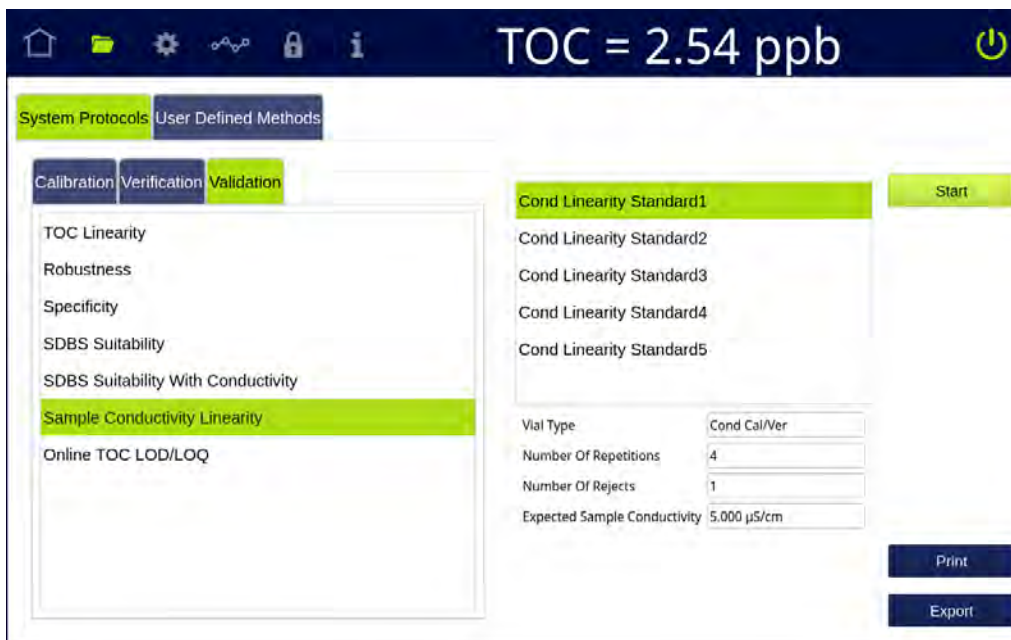

5.4 Select **Sample Conductivity Linearity** and press **START**.

5.5 If using a standard iOS System, go to step [5.7](#).

5.6 If using a Super iOS System, follow the prompts for the drain and rinse options (described in ["Super iOS Drain/Rinse" on page 228](#)).

5.6.1 A *Please insert...* dialog box appears.

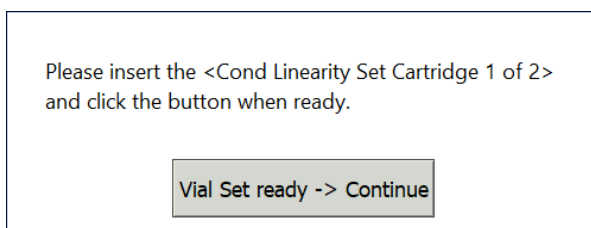

5.6.2 Insert **Conductivity Linearity Set (Cartridge 1 of 2)** and press **VIAL SET READY -> CONTINUE**., then go to step [5.6.11](#).

If using individual vials, **do not** insert them. Press **VIAL SET READY-> CONTINUE**. See ["Using Individual Vials in the Super iOS" on page 229](#) for more information.

- Port 1 = 5 µS/cm Cond
- Port 2 = 10 µS/cm Cond
- Port 3 = 25 µS/cm Cond



5.6.3 **(Individual vials only)** A Conductivity Temperature Compensation dialog box appears.

5.6.4 Select the temperature compensation algorithm from the list of options and press **APPLY SETTINGS** to continue.

5.6.5 A *Please specify the Conductivity Standard value...* dialog box appears.



NOTE: Each conductivity linearity standard value is user-definable within the specified range.

- 5.6.6 Leave the default value in the Standard Cond 1 field or press inside the field to use the numeric keypad to enter a new value and press **OK**. A *Please specify the Conductivity Standard value...* dialog box appears.

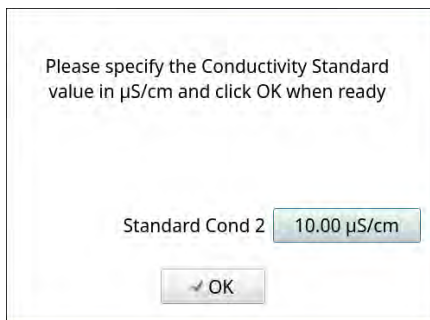

Please specify the Conductivity Standard value in $\mu\text{S}/\text{cm}$ and click OK when ready

Standard Cond 2 10.00 $\mu\text{S}/\text{cm}$

✓ OK

- 5.6.7 Leave the default value in the Standard Cond 2 field or press inside the field to use the numeric keypad to enter a new value and press **OK**. A *Please specify the Conductivity Standard value...* dialog box appears.

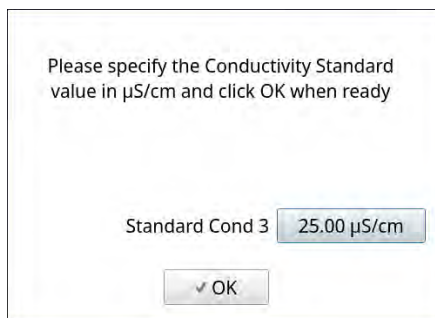

Please specify the Conductivity Standard value in $\mu\text{S}/\text{cm}$ and click OK when ready

Standard Cond 3 25.00 $\mu\text{S}/\text{cm}$

✓ OK

- 5.6.8 Leave the default value in the Standard Cond 3 field or press inside the field to use the numeric keypad to enter a new value and press **OK**. A *Please specify the Conductivity Standard value...* dialog box appears.

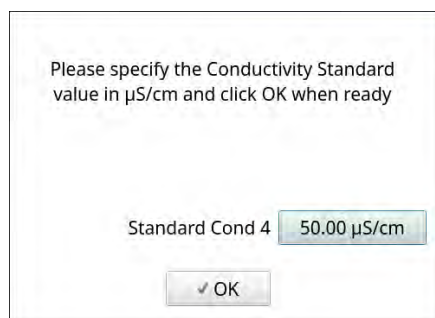

Please specify the Conductivity Standard value in $\mu\text{S}/\text{cm}$ and click OK when ready

Standard Cond 4 50.00 $\mu\text{S}/\text{cm}$

✓ OK



5.6.9 Leave the default value in the Standard Cond 4 field or press inside the field to use the numeric keypad to enter a new value and press **OK**. A *Please specify the Conductivity Standard value...* dialog box appears.

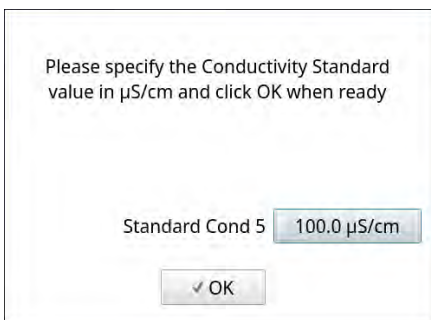

5.6.10 Leave the default value in the Standard Cond 5 field or press inside the field to use the numeric keypad to enter a new value and press **OK**.

5.6.11 When analysis of the vial set is complete, a *Please insert the Conductivity Linearity Set...* dialog box appears.

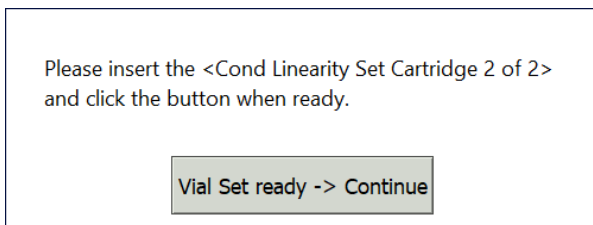

5.6.12 Remove **Conductivity Linearity Set (Cartridge 1 of 2)**, then insert **Conductivity Linearity Set (Cartridge 2 of 2)** (or insert individual vials in the following ports) and press **VIAL SET READY -> CONTINUE**. The Analyzer begins analysis of the vial set.

- Port 2 = **50 μS/cm Cond**
- Port 3 = **100 μS/cm Cond**

5.6.13 When analysis of the vial set is complete, remove it from the Super iOS. If a *Rinse After...* option was selected, follow the on-screen prompts for rinsing.

5.6.14 Go to step [5.8](#).

5.7 If using a standard iOS System:

5.7.1 A Conductivity Temperature Compensation dialog box appears.

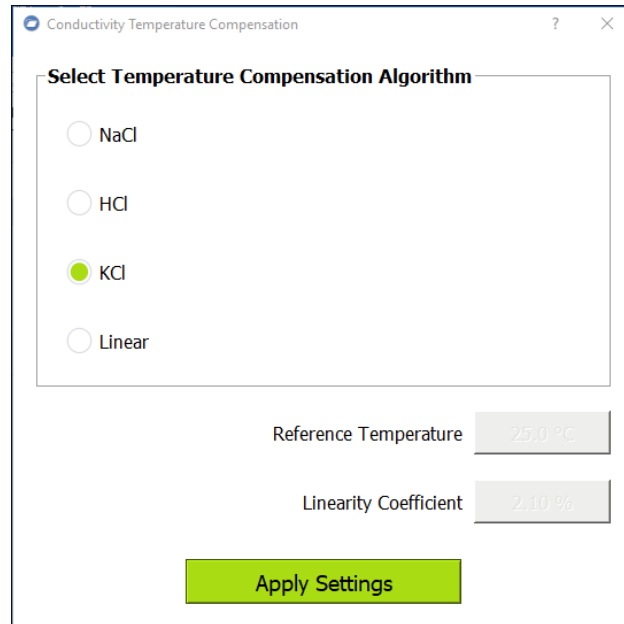

Conductivity Temperature Compensation

Select Temperature Compensation Algorithm

NaCl

HCl

KCl

Linear

Reference Temperature 25.0 °C

Linearity Coefficient 2.10 %

Apply Settings

5.7.2 Select the temperature compensation algorithm from the list of options and press **APPLY SETTINGS** to continue.

5.7.3 A *Please specify the Conductivity Standard value...* dialog box appears.



NOTE: Each conductivity linearity standard value is user-definable within the specified range.

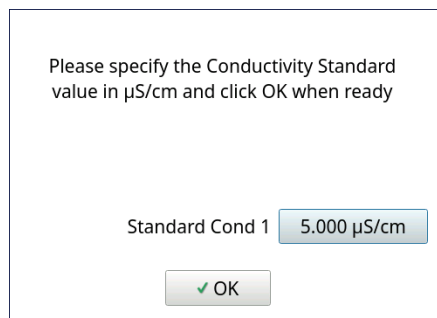

Please specify the Conductivity Standard value in $\mu\text{S}/\text{cm}$ and click OK when ready

Standard Cond 1 5.000 $\mu\text{S}/\text{cm}$

✓ OK



- 5.7.4 Leave the default value in the Standard Cond 1 field or press inside the field to use the numeric keypad to enter a new value and press **OK**. A *Please specify the Conductivity Standard value...* dialog box appears.

- 5.7.5 Leave the default value in the Standard Cond 2 field or press inside the field to use the numeric keypad to enter a new value and press **OK**. A *Please specify the Conductivity Standard value...* dialog box appears.

- 5.7.6 Leave the default value in the Standard Cond 3 field or press inside the field to use the numeric keypad to enter a new value and press **OK**. A *Please specify the Conductivity Standard value...* dialog box appears.

- 5.7.7 Leave the default value in the Standard Cond 4 field or press inside the field to use the numeric keypad to enter a new value and press **OK**. A *Please specify the Conductivity Standard value...* dialog box appears.

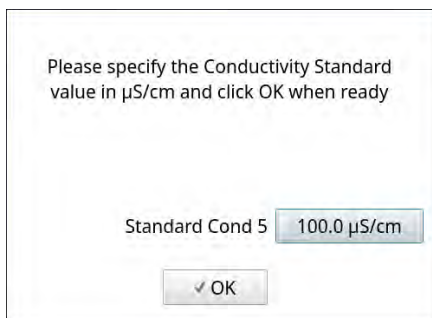

- 5.7.8 Leave the default value in the Standard Cond 5 field or press inside the field to use the numeric keypad to enter a new value and press **OK**.

- 5.7.9 A *Please insert the 5 μS/cm Standard vial...* dialog box appears.

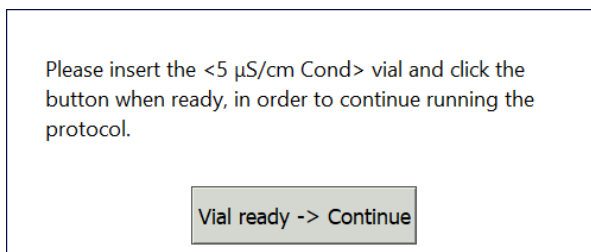

- 5.7.10 Open the door to the iOS System and wait 30 seconds for water to drain.

- 5.7.11 Insert the **5 μS/cm Standard** vial into the iOS System and press **VIAL READY-> CONTINUE**. The Analyzer begins analysis of the vial.

- 5.7.12 When analysis of the **5 μS/cm Standard** vial is complete, a *Please insert the 10 μS/cm Standard vial...* dialog box appears.

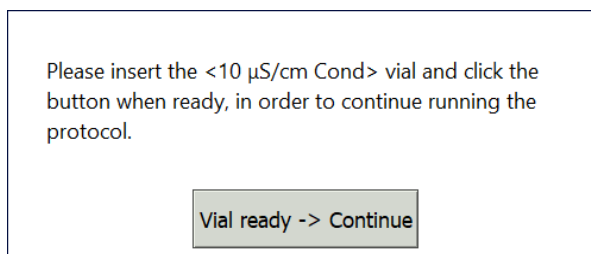

- 5.7.13 Remove the **5 μS/cm Standard** vial, then insert the **10 μS/cm** vial into the iOS System and press **VIAL READY-> CONTINUE**. The Analyzer begins analysis of the vial.



5.7.14 When analysis of the 10 $\mu\text{S}/\text{cm}$ Standard vial is complete, a *Please insert the 25 $\mu\text{S}/\text{cm}$ Standard vial...* dialog box appears.

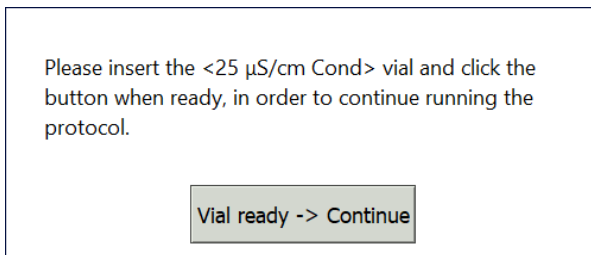

5.7.15 Remove the 10 $\mu\text{S}/\text{cm}$ Standard vial, then insert the 25 $\mu\text{S}/\text{cm}$ vial into the iOS System and press **VIAL READY-> CONTINUE**. The Analyzer begins analysis of the vial.

5.7.16 When analysis of the 25 $\mu\text{S}/\text{cm}$ Standard vial is complete, a *Please insert the 50 $\mu\text{S}/\text{cm}$ Standard vial...* dialog box appears.

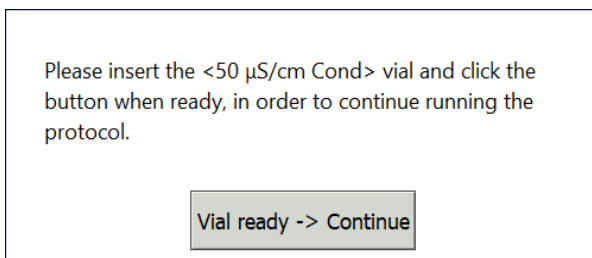

5.7.17 Remove the 25 $\mu\text{S}/\text{cm}$ Standard vial, then insert the 50 $\mu\text{S}/\text{cm}$ vial into the iOS System and press **VIAL READY-> CONTINUE**. The Analyzer begins analysis of the vial.

5.7.18 When analysis of the 50 $\mu\text{S}/\text{cm}$ Standard vial is complete, a *Please insert the 100 $\mu\text{S}/\text{cm}$ Standard vial...* dialog box appears.

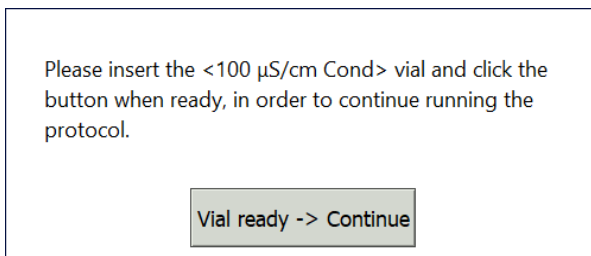

5.7.19 Remove the 50 $\mu\text{S}/\text{cm}$ Standard vial, then insert the 100 $\mu\text{S}/\text{cm}$ vial into the iOS System and press **VIAL READY-> CONTINUE**. The Analyzer begins analysis of the vial.

Chapter 6 CALIBRATION AND SYSTEM PROTOCOLS

5.7.20 When analysis of the vial is complete, remove it from the iOS and press **VIAL REMOVED -> CONTINUE**.

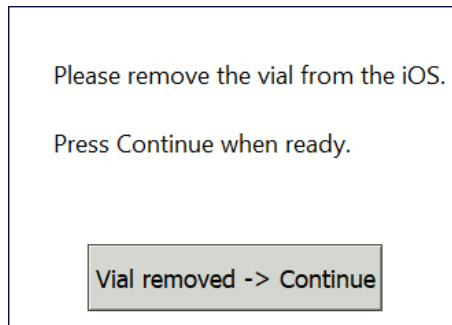

5.8 The *Sample Conductivity Linearity: Protocol Complete* screen appears with the *Summary* tab active and multiple tabs available for review, as follows:

Vial 1 Vial 2 Vial 3 Vial 4 Vial 5 Summary

Sample Conductivity Linearity: Protocol Complete

	Value	Limit	Result
Correlation Coefficient (R)	1.0000	N/A	N/A
Square of Correlation Coefficient (R ²)	1.0000	≥ 0.999	Passed
Regression Slope	0.994	N/A	N/A
Regression y-intercept	0.446 μS/cm	N/A	N/A
Residual Sum of Squares	0.036 μS/cm ²	N/A	N/A

Linearity Plot

Print Export Close



- Vial 1–5 — Select these tabs to view analysis details for each standard.
- Summary — Select to view the summary of analysis, including a *passed* or *failed* result. It also contains the **CLOSE**, **PRINT**, and **EXPORT** buttons.
- The **LINEARITY PLOT** button shows a graph of sample conductivity linear regression.

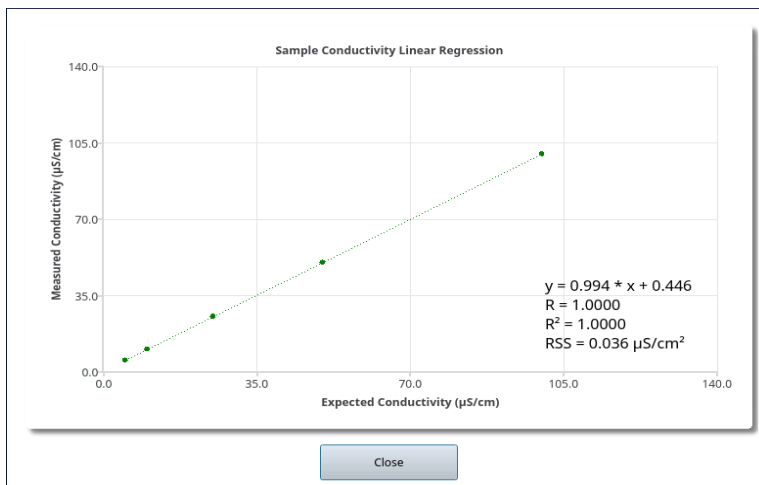

5.9 Referencing the *Summary* tab, record the results data on the *Sample Conductivity Protocol Worksheet*.

5.10 To print or export the results, press the corresponding button.

Online TOC LOD/LOQ Protocol (Optional)

1.0 INTRODUCTION

Perform this protocol to determine the Limit of Detection (LOD) and Limit of Quantitation (LOQ) for a Sievers M500 TOC Analyzer operating in Online mode.

2.0 SCOPE

This procedure applies to the Sievers M500 TOC Analyzers. The instrument should be calibrated and the analyst performing this protocol should be familiar with the terminology and operation of the Analyzer.

This protocol determines the LOD and the LOQ for Sievers M500 TOC Analyzers operating in Online mode. SUEZ has predetermined the LOD of 0.03 ppb using highly stable, low-TOC water under controlled conditions. For additional information on this LOD evaluation, contact Technical Support or your local service provider.

LOD is used to evaluate when a signal is a result of instrument noise or analyte response. This can be validated when using a highly stable, low-TOC water system. LOQ is the value established to provide guidance on meaningful versus non-meaningful data. This incorporates all conditions at the operation site. While Sievers M500 TOC Analyzers measure carbon concentration at very low levels, it is important to document the level above which the TOC result is meaningful.

Data above the user-determined LOQ are considered valid. Data obtained above the LOD but below the LOQ indicate the presence of TOC, but the accuracy of the measurements cannot be quantified. Values in this range are considered suspect. Data above the user-determined LOQ are considered valid.

3.0 MATERIALS

- 3.1 Sievers M500 TOC Analyzer, connected to a water system with stable TOC level.



NOTE: *A water system with a stable TOC level yields precise measurements, which will therefore produce lower values for LOD and LOQ.*

- 3.2 *Online TOC LOD/LOQ Protocol Worksheet*



4.0 DEFINITIONS

4.1 NONE

5.0 PROCEDURE

5.1 (OPTIONAL) If DataGuard is enabled, log in to the Analyzer with a User ID and the appropriate password.

5.2 Connect the Analyzer to a continuous supply from a high-quality water system.

5.3 Allow the Analyzer to rinse until the TOC measurements stabilize.

5.4 Press **STOP ANALYSIS** .

5.5 On the *System Protocols*  screen, select the *Validation* tab.

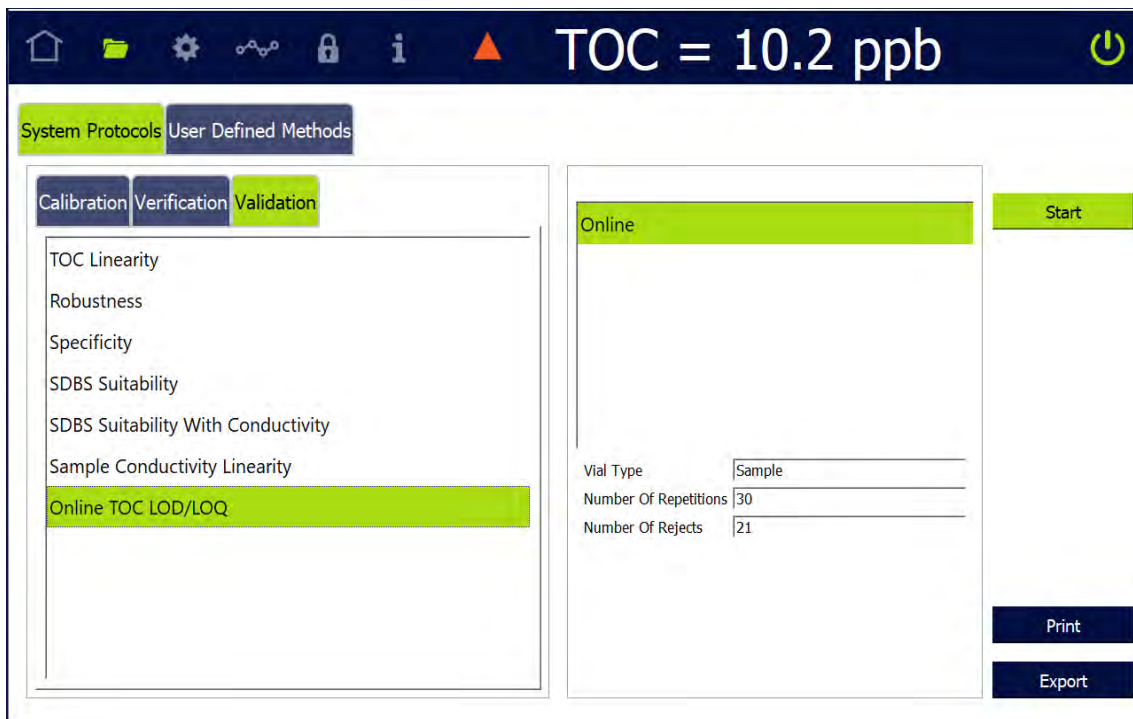

5.6 Select **Online TOC LOD/LOQ**, then press **START**.

- 5.7 When the protocol completes, the *Online TOC LOD/LOQ: Protocol Complete* screen appears with the *Summary* tab active.

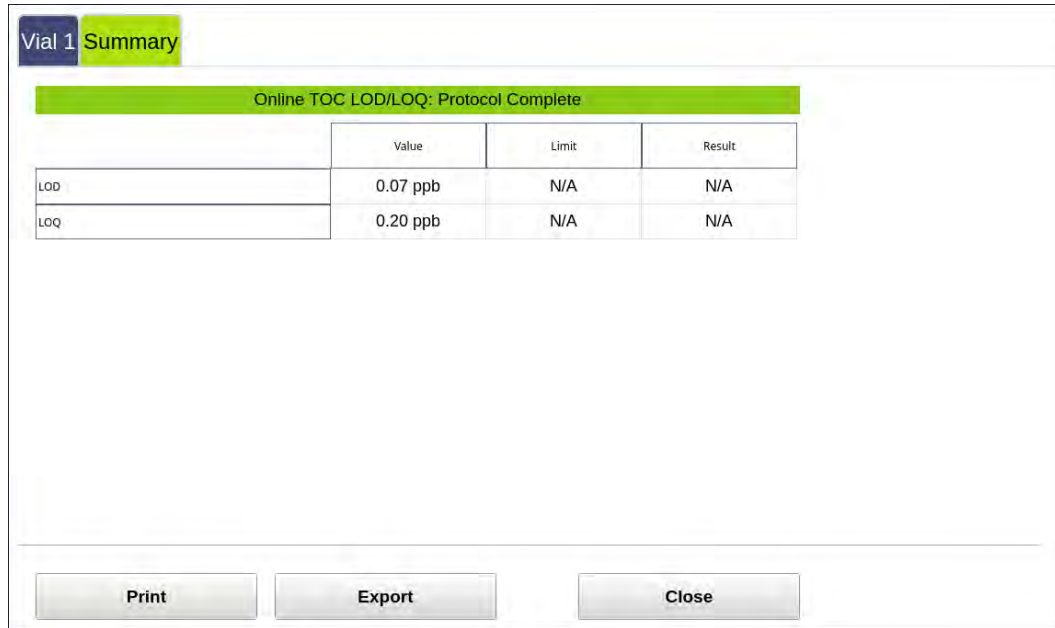

Vial 1 Summary

Online TOC LOD/LOQ: Protocol Complete

	Value	Limit	Result
LOD	0.07 ppb	N/A	N/A
LOQ	0.20 ppb	N/A	N/A

Print Export Close

- 5.8 Referencing the *Summary* tab, record the results data on the *Online TOC LOD/LOQ Protocol Worksheet*.
- 5.9 To print or export the results, press the corresponding button.



REVIEWING CALIBRATION AND VERIFICATION HISTORY

To review the results summaries of past calibrations, follow these steps:

1. On the *Data*  screen, select the *System Protocols and Grab Methods Data* tab.

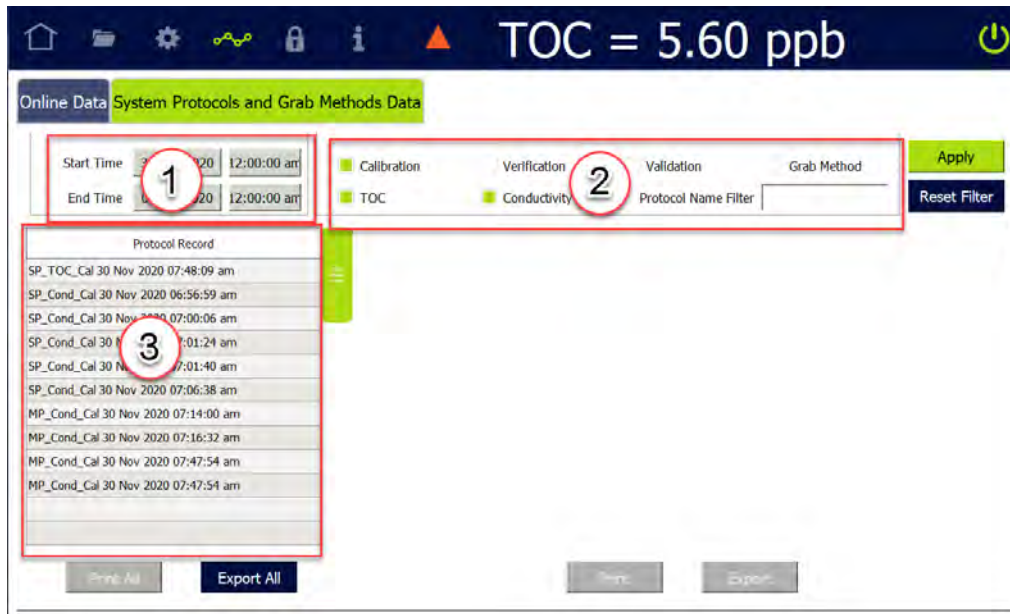

2. (at 1) Select the date and time range in which to search for results.
3. (at 2) Select and de-select the check boxes to filter the results to be displayed and press **APPLY** (or press **RESET FILTER** to return to the default):
 - Calibration
 - Verification
 - Validation
 - Grab Method
 - TOC
 - Conductivity

Select the Protocol Name Filter field to enter all or part of a protocol record name to search for.

Chapter 6 CALIBRATION AND SYSTEM PROTOCOLS

4. (at 3) Select a Protocol Record from the list. The selected record appears with the *Summary* tab active and other tabs available for review:

The screenshot displays the software interface for the Sievers M500 TOC Analyzer. At the top, a dark blue header shows 'TOC = 5.60 ppb' and a power icon. Below this, a navigation bar includes 'Online Data' and 'System Protocols and Grab Methods Data'. The main area is divided into several sections:

- Filtering Section:** Includes 'Start Time' (30 Nov 2020 12:00:00 am) and 'End Time' (01 Dec 2020 12:00:00 am) fields. There are checkboxes for 'Calibration', 'Verification', 'Validation', 'Grab Method', 'TOC', and 'Conductivity'. A 'Protocol Name Filter' field is also present, along with 'Apply' and 'Reset Filter' buttons.
- Protocol Record List:** A table listing several records. The selected record is 'MP_Cond_Cal 30 Nov 2020 04:03:06 pm'.
- Summary Tab:** Active for the selected record, showing a title bar with 'Vial 1 | Vial 2 | Vial 3 | Summary'. The main content area displays the record details: '30 Nov 2020 04:03 pm Sample Conductivity Multi-point Calibration: Rejected'.
- Summary Table:** A table with columns 'Value', 'Limit', and 'Result'.

	Value	Limit	Result
100.0 µS/cm Standard RSD	N/A	≤ 0.00 %	Passed
146.9 µS/cm Standard RSD	2.00 %	≤ 0.99 %	Failed
718.0 µS/cm Standard RSD	0.00 %	≤ 0.87 %	Failed
Cell Constant % Difference	2.00 %	± 0.00 %	Failed
Regression Slope	99999.000	N/A	N/A
Square of Correlation Coefficient (R ²)	2.000	≥ 0.994	Failed
Old Sample Cell Constant	0.0000	N/A	N/A
New Sample Cell Constant	2.0001	N/A	N/A
- Action Buttons:** 'Print All', 'Export All', 'Print', and 'Export' buttons are located at the bottom of the interface.

5. Press **PRINT** to print the selected Protocol Record. Press **PRINT ALL** to print all Protocol Records.
6. Press **EXPORT** to output the selected Protocol Record to a USB storage device or a network location. Press **EXPORT ALL** to output all Protocol Records.
 - 6.1 The next screen shows file type, file name, and path options for the system settings export file.
 - 6.2 Select the Export File Type from the list of options on the right side of the screen.
 - 6.3 The filename appears as the date/time stamp of the export. You can change this filename by selecting the File Name field and using the on-screen keyboard to type a file name.
 - 6.4 Press **SAVE** to export the protocol data.



TOC Single Point Calibration Worksheet

Company Name	
Analyzer Serial Number	Firmware Version
Analyzer Type	Analyzer Location

<p>PASS/FAIL CRITERIA:</p> <p>Cal Blank 1 IC RSD \leq 3.00%</p> <p>Cal Blank 1 TC RSD \leq 3.0%</p> <p>1.5 ppm TOC RSD \leq 3.0%</p> <p>Change in IC Slope \pm 20.0%</p> <p>Change in TC Slope \pm 20.0%</p> <p>The attached data will indicate a <i>Passed</i> or <i>Failed</i> condition.</p>
<p>Results: <input type="checkbox"/> <i>Passed</i> <input type="checkbox"/> <i>Failed</i></p>

Performed by:	Date:
Reviewed by:	Date:
Verified by:	Date:

THIS PAGE IS INTENTIONALLY LEFT BLANK.



TOC Multi-Point Calibration Worksheet

Company Name	
Analyzer Serial Number	Firmware Version
Analyzer Type	Analyzer Location

<p>PASS/FAIL CRITERIA:</p> <p>Cal Blank 1 IC RSD \leq 3.00%</p> <p>Cal Blank 1 TC RSD \leq 3.00%</p> <p>1.5 ppm TOC RSD \leq 3.00%</p> <p>1 ppm TOC RSD \leq 3.00%</p> <p>500 ppb TOC RSD \leq 3.00%</p> <p>Change in IC Slope \pm 20.0%</p> <p>Change in TC Slope \pm 20.0%</p> <p>R-squared \geq 0.988</p> <p>The attached data will indicate a <i>Passed</i> or <i>Failed</i> condition.</p>
<p>Results: <input type="checkbox"/> <i>Passed</i> <input type="checkbox"/> <i>Failed</i></p>

Performed by:	Date:
Reviewed by:	Date:
Verified by:	Date:

THIS PAGE IS INTENTIONALLY LEFT BLANK.



Sample Conductivity Single Point Calibration Worksheet

Company Name	
Analyzer Serial Number	Firmware Version
Analyzer Type	Analyzer Location

Pass/Fail Criteria: Cal Standard RSD \leq 0.50% Cell Constant % Difference \pm 50.0% The attached data will indicate a <i>Passed</i> or <i>Failed</i> condition.
Results: <input type="checkbox"/> <i>Passed</i> <input type="checkbox"/> <i>Failed</i>

Performed by:	Date:
Reviewed by:	Date:
Verified by:	Date:

THIS PAGE IS INTENTIONALLY LEFT BLANK.



Sample Conductivity Multi-point Calibration Worksheet

Company Name	
Analyzer Serial Number	Firmware Version
Analyzer Type	Analyzer Location

<p>PASS/FAIL CRITERIA:</p> <p>Cal Standard 1 RSD \leq 0.50%</p> <p>Cal Standard 2 RSD \leq 0.50%</p> <p>Cal Standard 3 RSD \leq 0.50%</p> <p>Cell Constant % Difference \pm 50%</p> <p>R-squared \geq 0.990</p> <p>The attached data will indicate a <i>Passed</i> or <i>Failed</i> condition.</p>
<p>Results: <input type="checkbox"/> <i>Passed</i> <input type="checkbox"/> <i>Failed</i></p>

Performed by:	Date:
Reviewed by:	Date:
Verified by:	Date:

THIS PAGE IS INTENTIONALLY LEFT BLANK.



TC/IC Conductivity Autozero Worksheet

Company Name	
Analyzer Serial Number	Firmware Version
Analyzer Type	Analyzer Location

<p>TC Cell New Offset: _____</p> <p>TC Cell Old Offset: _____</p> <p>IC Cell New Offset: _____</p> <p>IC Cell Old Offset: _____</p>
<p>Results: <input type="checkbox"/> <i>Applied</i> <input type="checkbox"/> <i>Rejected</i></p>

Performed by:	Date:
Reviewed by:	Date:
Verified by:	Date:

THIS PAGE IS INTENTIONALLY LEFT BLANK.



TOC Autozero Worksheet

Company Name	
Analyzer Serial Number	Firmware Version
Analyzer Type	Analyzer Location

<p>New TOC Offset: _____</p> <p>Old TOC Offset: _____</p>
<p>Results: <input type="checkbox"/> <i>Applied</i> <input type="checkbox"/> <i>Rejected</i></p>

Performed by:	Date:
Reviewed by:	Date:
Verified by:	Date:

THIS PAGE IS INTENTIONALLY LEFT BLANK.



Sample Conductivity Autozero Worksheet

Company Name	
Analyzer Serial Number	Firmware Version
Analyzer Type	Analyzer Location

<p>New Sample Cell Offset: _____</p> <p>Old Sample Cell Offset: _____</p>
<p>Results: <input type="checkbox"/> <i>Applied</i> <input type="checkbox"/> <i>Rejected</i></p>

Performed by:	Date:
Reviewed by:	Date:
Verified by:	Date:

THIS PAGE IS INTENTIONALLY LEFT BLANK.



Accuracy & Precision Verification Worksheet

Company Name	
Analyzer Serial Number	Firmware Version
Analyzer Type	Analyzer Location

Pass/Fail Criteria: TOC % Difference \pm 7% TOC RSD \leq 3.00% The attached data will indicate a <i>Passed</i> or <i>Failed</i> condition.
Results: <input type="checkbox"/> <i>Passed</i> <input type="checkbox"/> <i>Failed</i>

Performed by:	Date:
Reviewed by:	Date:
Verified by:	Date:

THIS PAGE IS INTENTIONALLY LEFT BLANK.



Cell Calibration Verification Worksheet

Company Name	
Analyzer Serial Number	Firmware Version
Analyzer Type	Analyzer Location

Pass/Fail Criteria: Conductivity % Difference \pm 2.00% Conductivity RSD \leq 1.00% The attached data will indicate a <i>Passed</i> or <i>Failed</i> condition.
Results: <input type="checkbox"/> <i>Passed</i> <input type="checkbox"/> <i>Failed</i>

Performed by:	Date:
Reviewed by:	Date:
Verified by:	Date:

THIS PAGE IS INTENTIONALLY LEFT BLANK.



Resistance Verification Worksheet

Company Name	
Analyzer Serial Number	Firmware Version
Analyzer Type	Analyzer Location

Pass/Fail Criteria: Conductivity Error \pm 0.100 μS/cm The attached data will indicate a <i>Passed</i> or <i>Failed</i> condition.
Results: <input type="checkbox"/> <i>Passed</i> <input type="checkbox"/> <i>Failed</i>

Performed by:	Date:
Reviewed by:	Date:
Verified by:	Date:

THIS PAGE IS INTENTIONALLY LEFT BLANK.



System Suitability Worksheet

Company Name	
Analyzer Serial Number	Firmware Version
Analyzer Type	Analyzer Location

Pass/Fail Criteria: Rw Blank TOC (ppb) ≤ 100 ppb Response Efficiency 85% to 115% The attached data will indicate a <i>Passed</i> or <i>Failed</i> condition.
Results: <input type="checkbox"/> <i>Passed</i> <input type="checkbox"/> <i>Failed</i>

Performed by:	Date:
Reviewed by:	Date:
Verified by:	Date:

THIS PAGE IS INTENTIONALLY LEFT BLANK.



TOC Linearity Worksheet

Company Name	
Analyzer Serial Number	Firmware Version
Analyzer Type	Analyzer Location

<p>LINEARITY PASS/FAIL CRITERIA:</p> <p>Square of Correlation Coefficient (R^2) \geq 0.970</p> <p>The attached data will indicate a <i>Passed</i> or <i>Failed</i> condition.</p>

<p>Results: <input type="checkbox"/> <i>Passed</i> <input type="checkbox"/> <i>Failed</i></p>
--

LOD/LOQ REPETITIVE MEASUREMENTS METHOD USED
--

Limit of Detection (LOD):	
Limit of Quantitation (LOQ):	

LOD/LOQ EXTRAPOLATION MEASUREMENTS METHOD USED

Limit of Detection (LOD):	
Limit of Quantitation (LOQ):	

Performed by:	Date:
Reviewed by:	Date:
Verified by:	Date:

THIS PAGE IS INTENTIONALLY LEFT BLANK.



Specificity Protocol Worksheet

Company Name	
Analyzer Serial Number	Firmware Version
Analyzer Type	Analyzer Location

Pass/Fail Criteria: Relative Percent Recovery $\geq 85\%$ and $\leq 115\%$ The attached data will indicate a <i>Passed</i> or <i>Failed</i> condition.
Results: <input type="checkbox"/> <i>Passed</i> <input type="checkbox"/> <i>Failed</i>

Performed by:	Date:
Reviewed by:	Date:
Verified by:	Date:

THIS PAGE IS INTENTIONALLY LEFT BLANK.



Robustness Protocol Worksheet

Company Name	
Analyzer Serial Number	Firmware Version
Analyzer Type	Analyzer Location

Pass/Fail Criteria: Response Efficiency $\geq 85\%$ and $\leq 115\%$ The attached data will indicate a <i>Passed</i> or <i>Failed</i> condition.
Results: <input type="checkbox"/> <i>Passed</i> <input type="checkbox"/> <i>Failed</i>

Performed by:	Date:
Reviewed by:	Date:
Verified by:	Date:

THIS PAGE IS INTENTIONALLY LEFT BLANK.



SDBS Suitability Worksheet

Company Name	
Analyzer Serial Number	Firmware Version
Analyzer Type	Analyzer Location

	Value	Limit	Result
Rw Blank TOC		≤ 250 ppb	
500 ppb TOC Blank Corrected		≥ 450 ppb	
Results: <input type="checkbox"/> <i>Passed</i> <input type="checkbox"/> <i>Failed</i>			

Performed by:	Date:
Reviewed by:	Date:
Verified by:	Date:

THIS PAGE IS INTENTIONALLY LEFT BLANK.



SDBS Suitability with Conductivity Worksheet

Company Name	
Analyzer Serial Number	Firmware Version
Analyzer Type	Analyzer Location

	Value	Limit	Result
Rw Blank TOC		≤ 250 ppb	
500 ppb TOC Blank Corrected		≥ 450 ppb	
Sample Temperature		15.0 – 30.0 °C	
Conductivity % Difference		± 5.00%	
Conductivity RSD		< 2.00%	

Results: *Passed* *Failed*

Performed by:	Date:
Reviewed by:	Date:
Verified by:	Date:

THIS PAGE IS INTENTIONALLY LEFT BLANK.



Sample Conductivity Linearity Worksheet

Company Name	
Analyzer Serial Number	Firmware Version
Analyzer Type	Analyzer Location

<p>LINEARITY PASS/FAIL CRITERIA:</p> <p>Square of Correlation Coefficient (R^2) \geq 0.999</p> <p>The attached data will indicate a <i>Passed</i> or <i>Failed</i> condition.</p>
<p>Results: <input type="checkbox"/> <i>Passed</i> <input type="checkbox"/> <i>Failed</i></p>

Performed by:	Date:
Reviewed by:	Date:
Verified by:	Date:

THIS PAGE IS INTENTIONALLY LEFT BLANK.



Online TOC LOD/LOQ Protocol Worksheet (OPTIONAL)

Company Name	
Analyzer Serial Number	Firmware Version
Analyzer Type	Analyzer Location

Limit of Detection (LOD):	
Limit of Quantitation (LOQ):	

Performed by:	Date:
Reviewed by:	Date:
Verified by:	Date:

THIS PAGE IS INTENTIONALLY LEFT BLANK.

7

TROUBLESHOOTING

OVERVIEW

This chapter provides the starting point for troubleshooting basic issues with the Analyzer. For additional assistance, contact Technical Support or your local service provider. Installation and training by a qualified service technician is available.

STEP 1: VISUAL INSPECTION

After confirming that no warning or error messages are indicating a specific problem, proceed to a visual inspection of the Analyzer to identify any obvious physical problems or symptoms. Begin with an external visual inspection, and proceed to an internal visual inspection. If possible, perform the inspection with the Analyzer in analysis mode to verify that relevant modules are performing as intended.



NOTE: Be sure to fully inspect the Analyzer visually before proceeding with more in-depth troubleshooting. Many issues can be resolved with simple fixes.

Inspecting Externally

- Confirm that there are no leaks present at the sample inlet or the waste connections.
- Confirm that all cables are securely attached to the Analyzer.
- If sampling from vials, confirm that the needle in the iOS System is not obstructed.

Inspecting Internally

Open the Analyzer front panel and do the following:

- Check for leaks throughout the Analyzer; there should not be moisture on the inside floor of the Analyzer case.
- Confirm that the sample pump is turning.

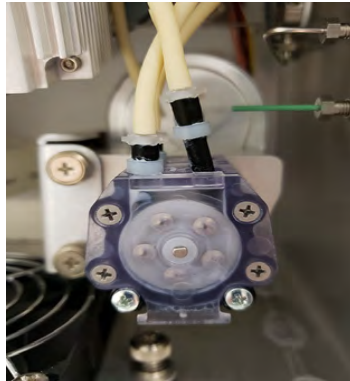

- Check to make sure there are no leaks from tubing in the DI water system.

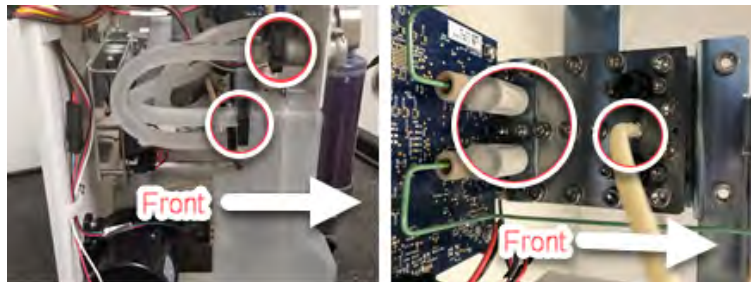

- Confirm that the DI water reservoir is full. If necessary, add water up to the *Full* line.



- Confirm that the resin cartridge is secured to the RUN position fitting.



- If maintenance work has recently been performed on the Analyzer, confirm that all electronics cables are securely attached.
- Make sure there are no air bubbles present in any of the DI Loop tubing.
- Make sure tubing is not kinked or obstructed.
- Make sure the UV lamp is working. During analysis, the window on the UV reactor will illuminate when the lamp is functioning properly.



NOTE: If tubing has become bent, kinked, or otherwise damaged, a tubing replacement kit is available from Technical Support or your local service provider.

STEP 2: REVIEW WARNINGS AND ERRORS

The next step in troubleshooting is to review the Warnings and Errors list. For an explanation of warning and errors, refer to [Appendix C, "Warning and Error Descriptions."](#)

When an error or warning occurs, a dialog box will appear that contains a yellow warning triangle and warning text.

Reviewing Errors and Warnings

To review errors and warnings

Use the *Error* tab to search and view the list of errors and warnings. After filtering the list, return to the full list of errors and warnings by pressing **RESET**.

1. On the *Settings*  screen, select the *Errors* tab.

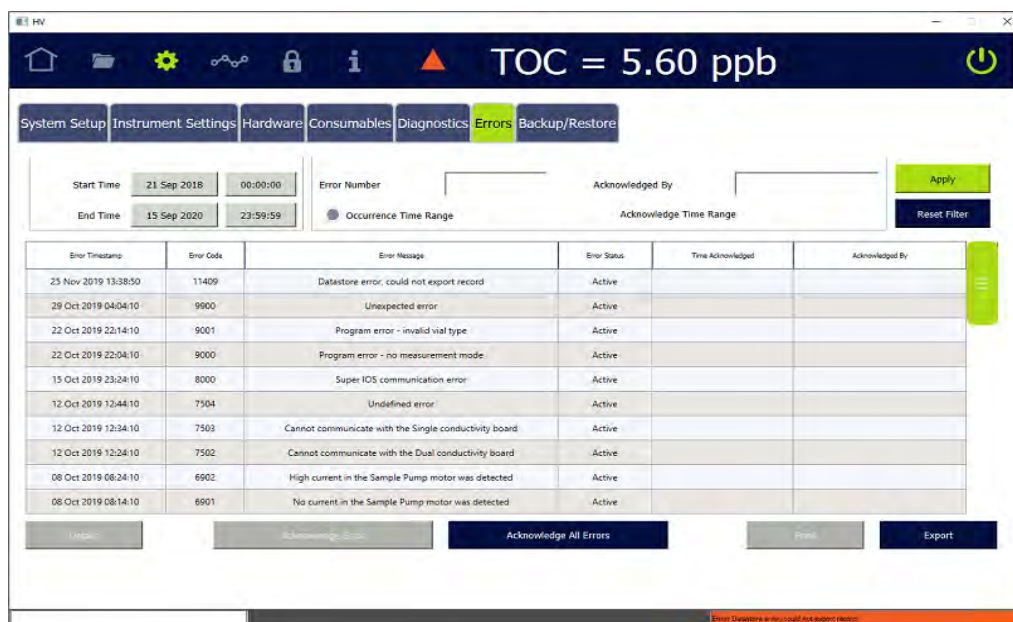

Error Timestamp	Error Code	Error Message	Error Status	Time Acknowledged	Acknowledged By
25 Nov 2019 13:38:50	11409	Datatore error; could not export record	Active		
29 Oct 2019 04:04:10	9900	Unexpected error	Active		
22 Oct 2019 22:14:10	9001	Program error - invalid vial type	Active		
22 Oct 2019 22:04:10	9000	Program error - no measurement mode	Active		
15 Oct 2019 23:24:10	8000	Super IOS communication error	Active		
12 Oct 2019 12:44:10	7904	Undefined error	Active		
12 Oct 2019 12:34:10	7503	Cannot communicate with the Single conductivity board	Active		
12 Oct 2019 12:24:10	7502	Cannot communicate with the Dual conductivity board	Active		
08 Oct 2019 08:24:10	6902	High current in the Sample Pump motor was detected	Active		
08 Oct 2019 08:14:10	6901	No current in the Sample Pump motor was detected	Active		

2. Review the list of messages (listed most recent to earliest). Use the scroll bar on the right to view any additional lines and pages of messages.
3. To sort messages by time range type, press one of the following options:
 - Occurrence Time Range
 - Acknowledge Time Range
4. To search for messages of a specific date range, press **START TIME** (date) to display and select from an interactive calendar to set the beginning date. Press the **END TIME** (date) to display and select from an interactive calendar set the ending date.



Leave the default time or press **START TIME** (time) to display a keypad. Enter the numbers for **hh:mm:ss** and press **OK**. Press **END TIME** (time) to display a keypad. Enter the numbers for **hh:mm:ss** and press **OK**. Press **APPLY** to display the search results.

5. To search for a message by warning or error number, press the **Error Number** field to display a keypad. Enter the number of the warning or error and press **OK**. Press **APPLY** to display the message.
6. To search for an acknowledged message by User ID, press the *Acknowledged By* field to display the User Filter dialog box. Enter the User ID and press **OK**. Press **APPLY** to display the search results.
7. Press **RESET FILTER** to clear the filters and display the full error list.
8. To view additional details of a message, select the message line and press **DETAILS**. The *Details* dialog box appears. This dialog box displays the time the error occurred, a description of the error, and the Error Status (whether or not the error has been acknowledged by the user).

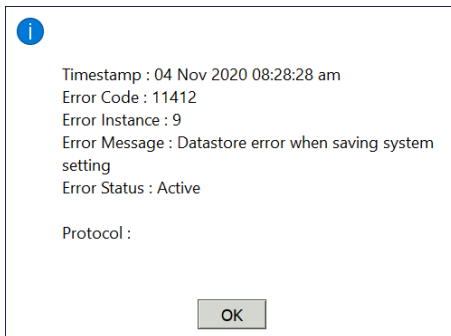

9. To acknowledge a warning or error appearing in the list, select a message line and press **ACKNOWLEDGE ERROR**.
10. To acknowledge **all** the warning and errors appearing in the list, press **ACKNOWLEDGE ALL ERRORS**.
11. To print the list of warnings and errors, press **PRINT**. A confirmation message appears.
12. Press **OK** to return to the *Error* tab.



NOTE: *The Analyzer prints only non-acknowledged warnings and errors.*

13. To export the history of **all** warnings and errors), press **EXPORT**.
14. The next screen shows file type, file name, and path options for the system settings export file. You can export to a USB storage device or a network location.



15. Select one of the following export file types from the list of options on the right side of the screen:

- .csv
- .xlsx
- .pdf
- .pdf (encrypted)
- .enc encrypted

16. The filename appears as the date/time stamp of the export. You can change this filename by selecting the File Name field and using the on-screen keyboard to type a file name.

17. Press **SAVE** to export the Error History.

WARNINGS AND ERROR MESSAGES

This section details some of the warnings and error messages that have troubleshooting steps that can be performed by the user. See Appendix C of this manual for a full list of warnings and error messages.

800—THE SAMPLE CONDUCTIVITY ANALOG READING IS OUT OF RANGE

This warning can occur if there is a sample flow problem. To troubleshoot:

Check the flow:

1. Navigate to the *Settings*  screen > *Hardware* tab. Select *Flow Sensor Setup*.

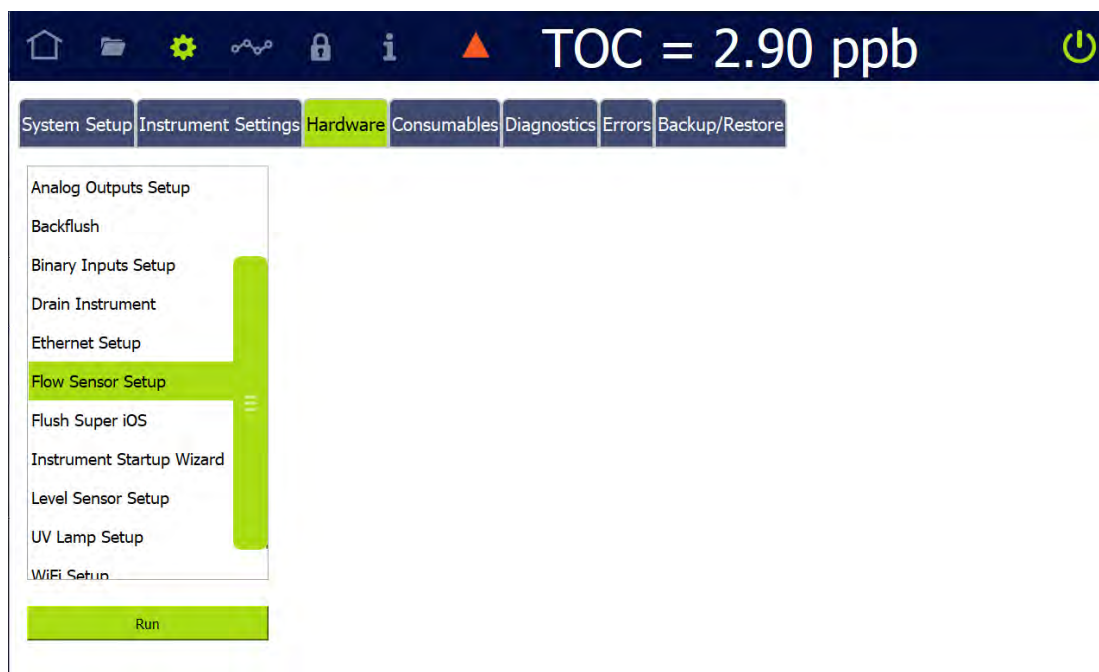

Chapter 7 TROUBLESHOOTING

2. Press **RUN**. The *Flow Sensor Setup* dialog box appears.

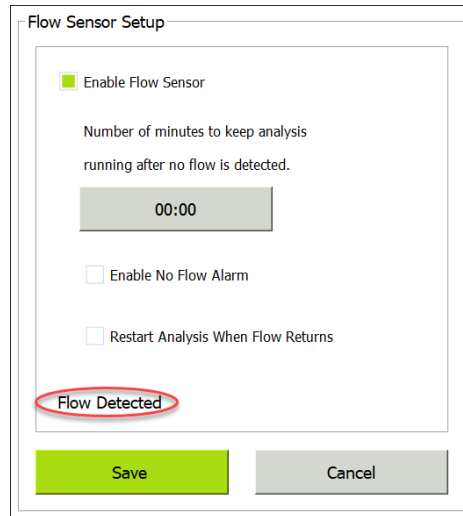

The image shows a dialog box titled "Flow Sensor Setup". It contains the following elements:

- A checked checkbox labeled "Enable Flow Sensor".
- A text label: "Number of minutes to keep analysis running after no flow is detected." followed by a text box containing "00:00".
- An unchecked checkbox labeled "Enable No Flow Alarm".
- An unchecked checkbox labeled "Restart Analysis When Flow Returns".
- A red oval highlighting the text "Flow Detected" at the bottom of the dialog.
- Two buttons at the bottom: a green "Save" button and a grey "Cancel" button.

3. Select *Enable Flow Sensor*. *Enable No Flow Alarm* and *Restart Analysis When Flow Returns* options are also available.
4. Press **SAVE** to enable the flow sensor.
5. If sample flow is detected, a *Flow Detected* message appears.
6. If the error persists, follow the steps in ["No Sample Flow Through the Analyzer" on page 377](#).

3100—UNEXPECTED DI LOOP LEVEL

This warning can occur if the water level in the DI Reservoir is low. To troubleshoot:

1. Check the water level in the DI reservoir. The water level should touch the FULL mark on the outside of the reservoir:



2. If the water level is low, add water by following the instructions in Basic Analyzer Operation on page 113.
3. If the DI reservoir is full when this error occurs, power cycle the Analyzer. Stop any analysis and press the Power Off  button in the Analyzer's firmware, then turn off the power switch. Wait 30 seconds, then turn on the power switch.
4. If the error persists, contact your local service provider or Technical Support for further assistance.

3102—DI FLOW ON IC/TC CHANNEL NOT DETECTED

This warning can occur if the flow in the IC/TC channel is low. To troubleshoot, check the flow through the restrictor tube by following the steps in ["No Sample Flow Through the Analyzer" on page 377](#).

STEP 3: REVIEW SOLUTIONS FOR BASIC PROBLEMS



If a visual inspection of the Analyzer does not help identify the source of the problem, consult the specific problems discussed in this section.

THE ANALYZER WILL NOT POWER ON

The Analyzer does not contain a user-replaceable fuse. If the Analyzer will not power on, confirm that the external circuit breaker has not been switched off. Also confirm that the electrical power lines that lead in to the Analyzer are attached securely to the terminal block, and that the grounding wire is connected.

CHECKING THE SAMPLE PUMP

While the Analyzer is operating, open the Analyzer front panel and make sure the sample pump is turning. If the pump is not turning and the Analyzer is operating (the display screen indicates that analysis is taking place), contact Technical Support or your local service provider for instructions.

Warning	
	To avoid potentially dangerous shock, Before opening the Analyzer, stop any analysis and power off the operating system. Press the Power Off  button in the Analyzer's firmware, then turn <i>off</i> the power switch and disconnect from the power supply. Any operation requiring access to the inside of the Analyzer without turning off power, including installation of maintenance items, could result in injury.
	To avoid potentially dangerous shock, do not touch anything inside the Analyzer while observing the sample pump during a visual inspection.

NO SAMPLE FLOW THROUGH THE ANALYZER

To troubleshoot a lack of flow through the Analyzer, follow these steps:

1. Perform a backflush procedure.
 - 1.1 Navigate to the **Settings**  screen > **Hardware** tab. Select **Backflush**.

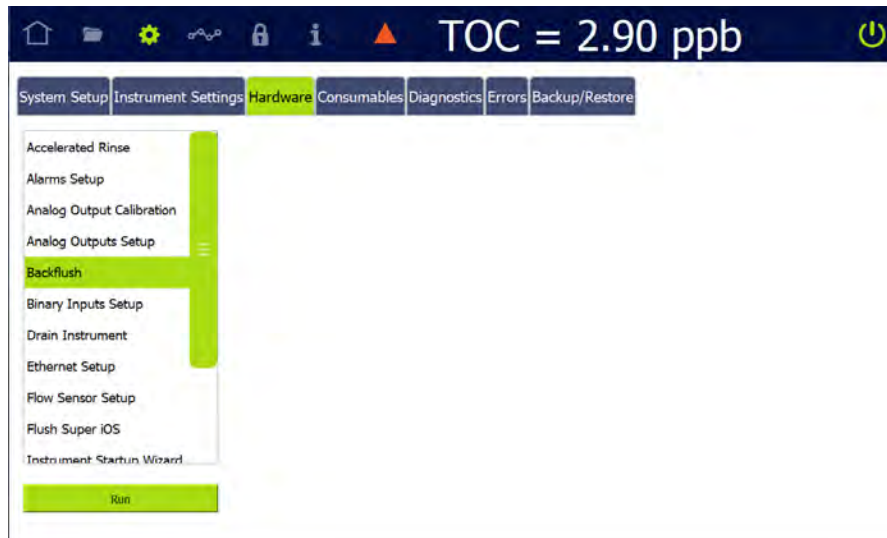

- 1.2 Press **RUN** and follow the on-screen instructions to complete the backflush procedure.

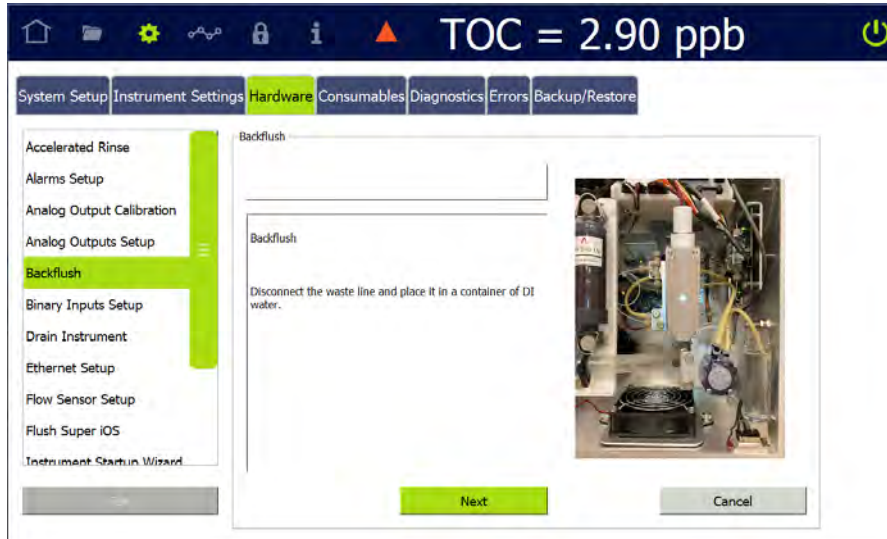

CONFIRM FLOW OF WATER THROUGH THE MEASUREMENT MODULE, DI SIDE

Make sure the Analyzer is powered on at all times, except when maintenance is being performed, to ensure that water flows through the Analyzer's fluidics module. Place the Analyzer in *Standby* mode to open valves. To check flow of water through the conductivity cells:

1. Locate the restrictor tube on the DI side of the fluidics module. It is a narrow, looped plastic tube.
2. Disconnect the PEEK fittings on each end of the restrictor tube.



3. Flush the tube with water, then reconnect it.
4. If the restrictor tube is clear, check the flow through the T-fitting that the restrictor tube is attached to. Disconnect the PEEK fittings from the T-fitting and verify flow by flushing the fitting with water.





5. If the T-fitting is clear, confirm that the DI pump is working.



6. If the sample flow error persists, contact your local service provider or Technical Support to replace the component that is causing the error, or for further assistance.

Negative, High, or Erratic Measurements

Many of the previous steps in this chapter will help troubleshoot negative or erratic measurements. If the previous steps did not remedy the situation, perform one of the following procedures.

TC/IC CONDUCTIVITY AUTOZERO

The TC/IC Conductivity Autozero protocol adjusts the IC and TC cell offsets. If the Analyzer is returning unusually high IC or TC values, or returning negative IC, TC, or conductivity values, a TC/IC Conductivity Autozero might be necessary. See ["TC/IC Conductivity Autozero Protocol" on page 257](#) for instructions.

SAMPLE CONDUCTIVITY CELL CALIBRATION

If for any reason the sample conductivity cell has been replaced, or if poor cell performance is suspected, perform a sample conductivity cell calibration. See ["Sample Conductivity Single Point Calibration Protocol" on page 243](#) and ["Sample Conductivity Multi-point Calibration Protocol" on page 249](#) for instructions.

SAMPLE CONDUCTIVITY AUTOZERO

If for any reason the sample conductivity cell has been replaced, or if poor cell performance is suspected, this protocol can correct conductivity measurements by determining the proper sample cell offset. See ["Sample Conductivity Autozero Protocol" on page 263](#) for instructions.

TOC AUTOZERO

The TOC Autozero corrects for minor differences in the response of the two CO₂ sensors. This adjustment may help when the Analyzer is reading very high or negative values. After running a system protocol, let the Analyzer run in Online mode for 30 minutes before performing a TOC Autozero. See ["TOC Autozero Calibration Protocol" on page 260](#) for instructions.

TOC OFFSET

At extremely low TOC concentrations, very small changes in water system conditions may make it difficult to use the TOC autozero procedure for the purposes of achieving instrument-to-instrument agreement consistent with the stated Analyzer specifications. If the TOC autozero procedure does not yield acceptable agreement between multiple instruments, utilize the manual TOC zero offset adjustment to adjust the TOC reading to match a known accurate reference value.



NOTE: *Adjusting the TOC offset value manually will affect all TOC readings by an amount equal to the amount of adjustment. This procedure should only be used when all other recommended methods of calibration and autozero have failed to allow multiple instruments to match within the stated accuracy specifications of the Analyzer.*

To set the TOC Offset, see ["Setting a User TOC Offset" on page 153](#) for instructions.

PROBLEMS CHANGING THE PROGRAM LANGUAGE

If the program language is changed by mistake and/or for help navigating back to your preferred language, follow these steps. These steps are designed to help find the correct buttons by their position rather than by the button label (which appears in the currently selected language).

1. Navigate to the **Settings**  screen, and select the leftmost tab (System Setup). Confirm that the top section (**Local Settings**) is displayed.

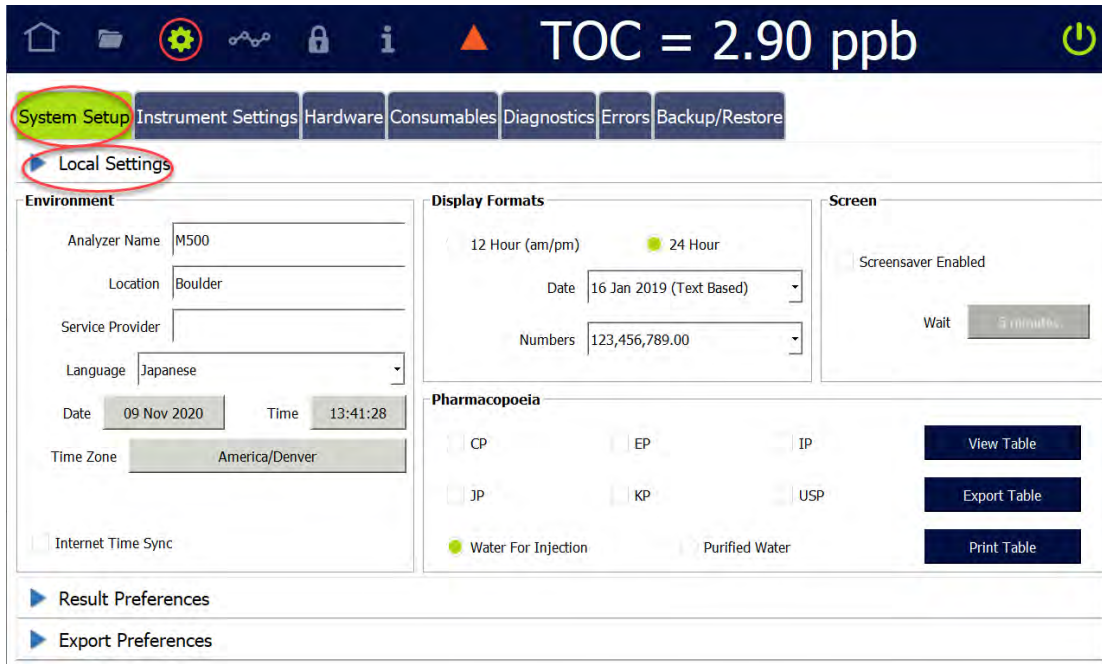

2. Count down four fields to the Language field, and press the arrow to display the drop-down menu.

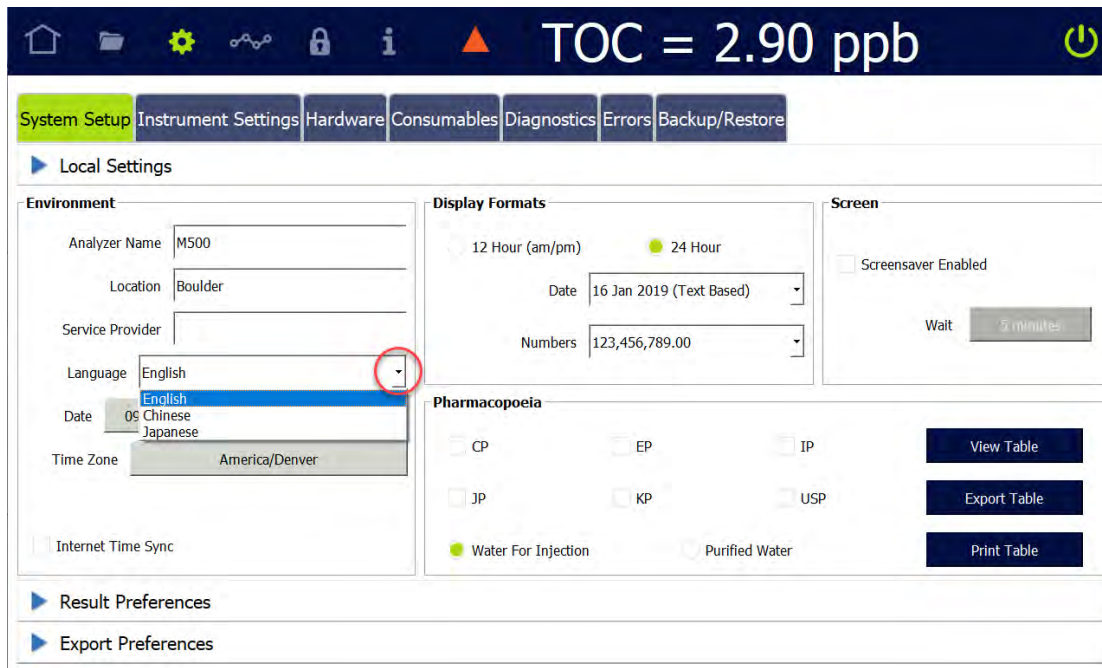

3. Select your language by pressing one of the following buttons. The program language changes immediately.
 - English (U.S.)
 - Chinese (Simplified).
 - Japanese

PROBLEMS WITH VIAL SET CARTRIDGES

If using a Super iOS and are having problems using vial sets in cartridges, do the following.

- Make sure the cartridge is properly seated in the Super iOS System. Remove the cartridge and re-insert it into the Super iOS System firmly.
- Make sure the cartridge is oriented properly. The label should face to the right, away from the Analyzer, so the contacts on the cartridge are close to Vial Port 1.
- Confirm the use involves the appropriate cartridge for the system protocol selected. For example, the Analyzer automatically checks to make sure a system suitability cartridge is not used to run calibration.

PROBLEMS WITH THE DI WATER PUMP

If there are air bubbles blocking the flow of water through the DI water pump, the pump may “squeal” or emit a continuous noise. This problem is more likely to happen when the DI water reservoir has not been filled properly. If the pump begins emitting a noise, try the following:

1. Turn off power to the Analyzer and wait 15 seconds.
2. Restore power to the Analyzer. Cycling power causes the DI pump to stop and start, potentially freeing a trapped air bubble. If the noise persists, turn off power to the Analyzer again.
3. Open the Analyzer front panel.
4. Check for large air bubbles in all the tubing that connects to the DI water reservoir. If large air bubbles are present, tap or manipulate the tubing to work the air bubbles out.
5. If simple manipulation of the tubing does not free the air bubbles, disconnect the fitting that connects to the DI water reservoir. Raise the tubing so that it is higher than the cartridge and remove the rubber vent cover. Move the tubing lower than the DI water reservoir, to force any air bubbles out of the tubing. Be prepared to raise the tubing quickly; as soon as all air is forced out of the tubing, water will begin to flow out of the tubing.

6. Check the level of the DI water reservoir. If the water level has dropped below the *Full* line, remove the rubber inlet cover from the top of the cartridge, add more water, and replace the inlet cover.
7. Restore power to the Analyzer. If the problem persists, repeat [Step 1](#) through [Step 6](#).

Using the Diagnostics Menu

The Analyzer provides a series of screens to test individual hardware features to ensure normal operation. This variety of individual modular analysis can help identify troubleshooting issues and/or eliminate possible causes to help further isolate the troubleshooting issue.

Navigate to the *Settings*  screen and select the *Diagnostics* tab. Three modules are available: System Tests, Service Diagnostics, and Level 1 Diagnostics.

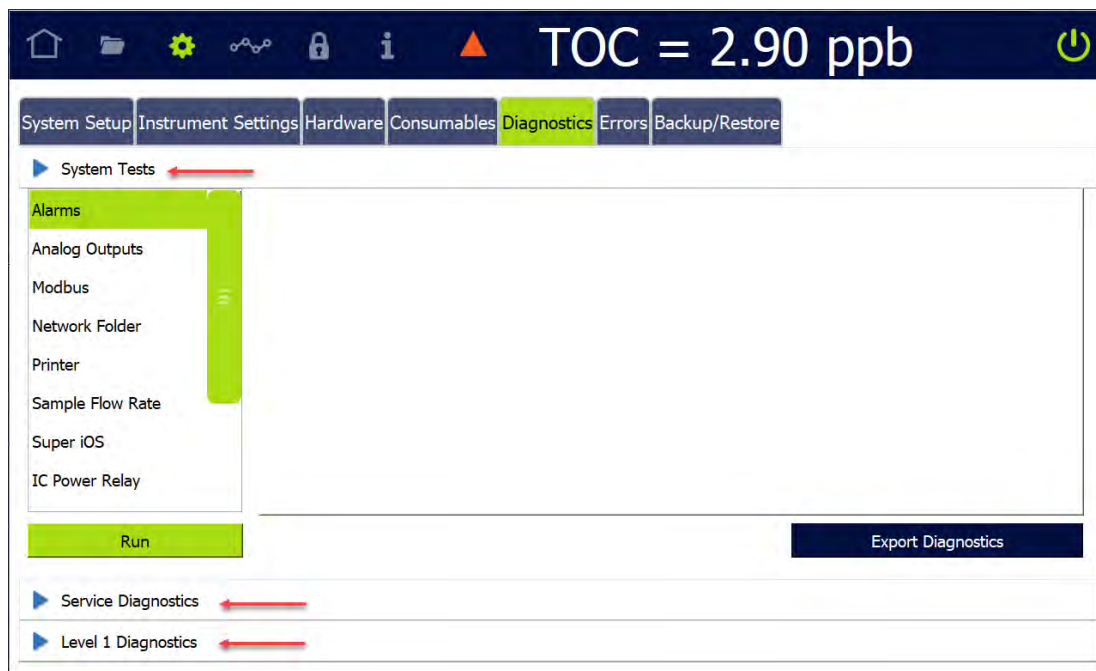

SYSTEM TESTS

The System Tests module contains the following procedures:

Alarms	Analog Outputs
Modbus	Network Folder
Printer	Sample Flow Rate
Super iOS	IC Power Relay
Internet Connection	USB Serial Loopback
Serial Loopback	WiFi

Alarms

Use this test to verify the functionality of the Analyzer's four alarms. From the *Diagnostics* tab, select *Alarms* and press **RUN** to display each alarm's current status and volume:

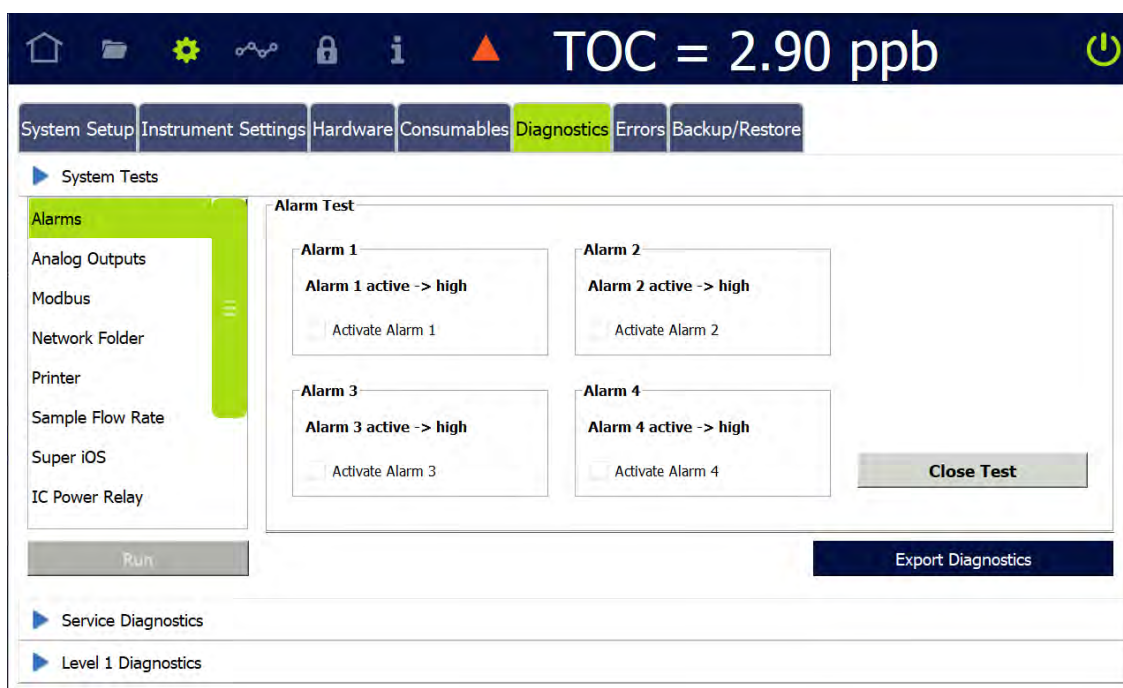



1. Select the *Activate Alarm* check box for an alarm to test its functionality.

Alarm Test

<div style="border: 1px solid black; padding: 5px; margin-bottom: 10px;"> <p>Alarm 1</p> <p>Alarm 1 active -> high</p> <p><input type="checkbox"/> Activate Alarm 1</p> </div> <div style="border: 1px solid black; padding: 5px;"> <p>Alarm 3</p> <p>Alarm 3 active -> high</p> <p><input type="checkbox"/> Activate Alarm 3</p> </div>	<div style="border: 1px solid black; padding: 5px; margin-bottom: 10px;"> <p>Alarm 2</p> <p>Alarm 2 active -> high</p> <p><input type="checkbox"/> Activate Alarm 2</p> </div> <div style="border: 1px solid black; padding: 5px;"> <p>Alarm 4</p> <p>Alarm 4 active -> high</p> <p><input type="checkbox"/> Activate Alarm 4</p> </div>
--	--

Close Test

2. To test another alarm, deselect the active alarm and select another *Activate Alarm* check box.
3. When you are done testing, deselect the last active alarm and press **CLOSE TEST** to exit the screen.



NOTE: To change alarm settings, follow the instructions at ["To setup alarm output" on page 107](#).

Analog Outputs

The Analyzer has up to three 4-20 mA analog outputs, depending on configuration. Use this test to verify the functionality of these outputs. From the *Diagnostics* tab, select *Analog Outputs* and press **RUN** to display the Analog Output Test:

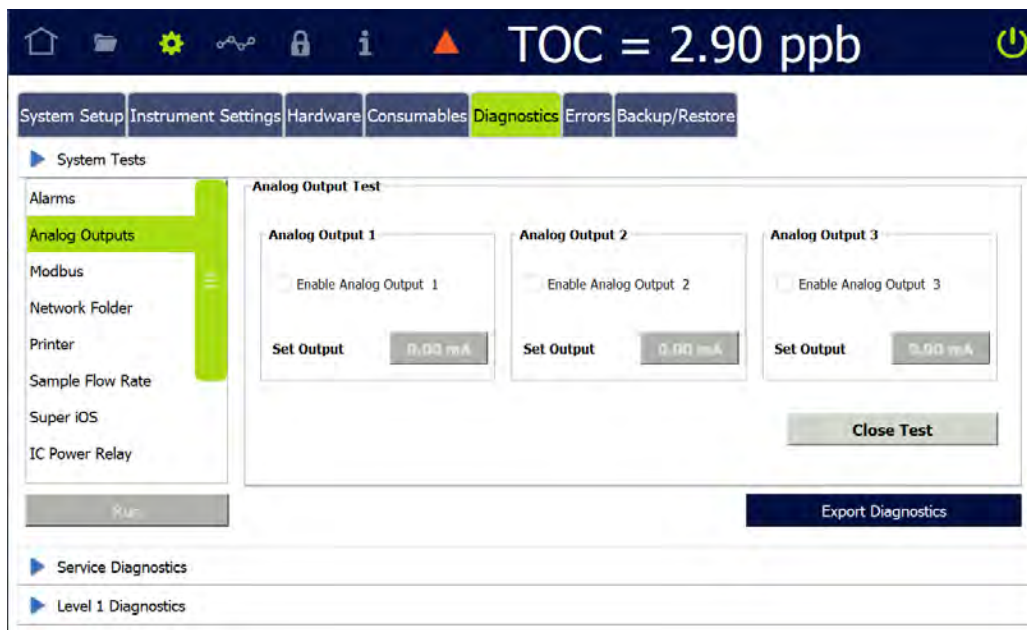

1. Select an *Enable Analog Output* check box to test its functionality. The **SET OUTPUT** button becomes available for that output.

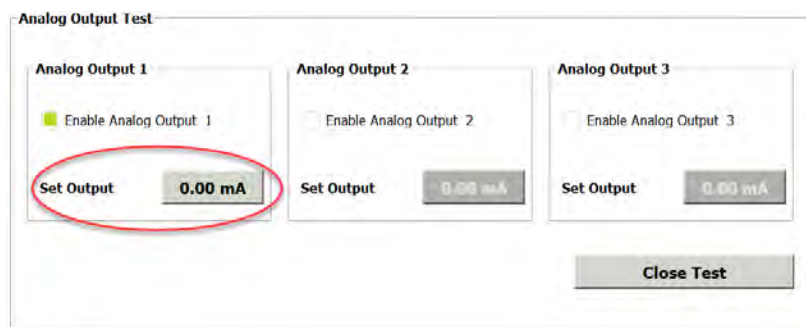

2. Use a multimeter to measure the output.
3. Press the **SET OUTPUT** button (**0.00 mA**) to display a numeric keypad. Enter the measured output and press **OK**.
4. To test additional analog outputs, deselect the current Enable Analog Output check box and repeat steps 1–3 for each output to be tested.
5. When you are done testing, deselect the last active output and press **CLOSE TEST** to exit the screen.

Modbus

Use this test to verify Modbus functionality. From the *Diagnostics* tab, select *Modbus* and press **RUN** to display the Modbus Test. A dialog box appears, instructing you to connect your Modbus client to the Analyzer at the displayed IP address:

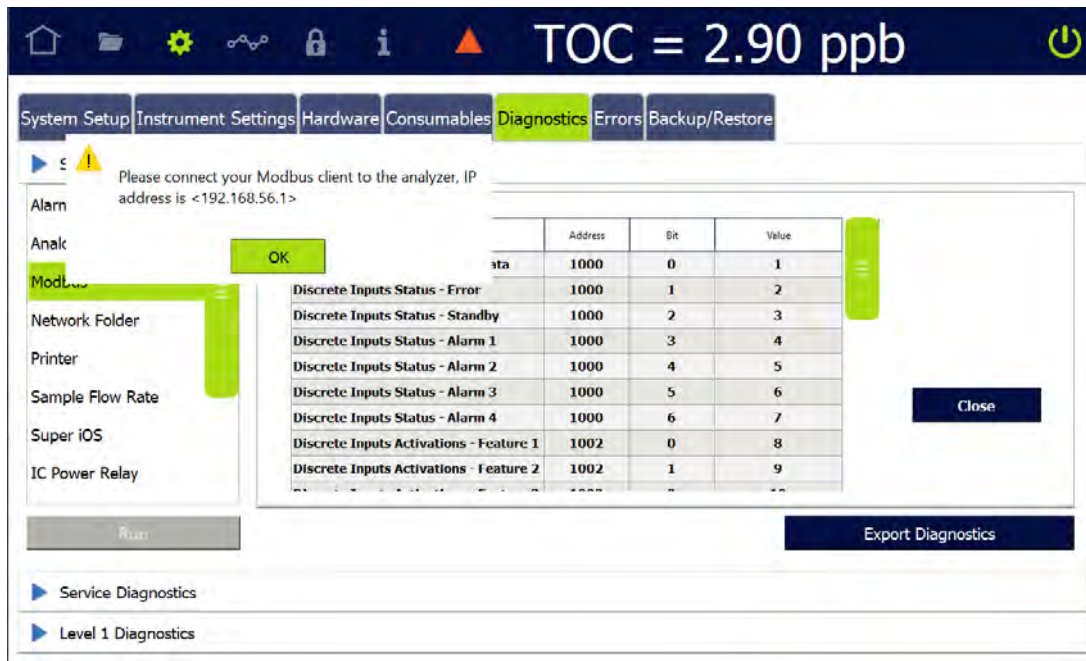

1. Connect the Modbus client as instructed and press **OK** to continue.
2. The *Modbus Test* screen displays a list of input statuses, activations, and other information. Sort this data by pressing the column headings at the top of each column (*Register Name*, *Address*, *Bit*, and *Value*). Scroll down using the scroll bar to see additional entries.

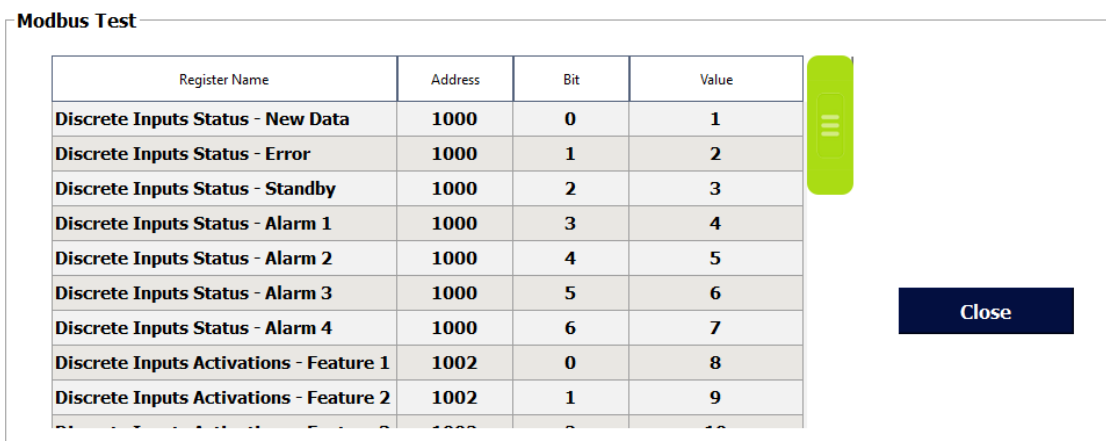

3. After reviewing the data, press **CLOSE** to exit the screen.

Network Folder

Use this test to verify connectivity between the Analyzer and a user-defined network location. From the *Diagnostics* tab, select *Network Folder* and press **RUN** to display the *Network Folder Test*:

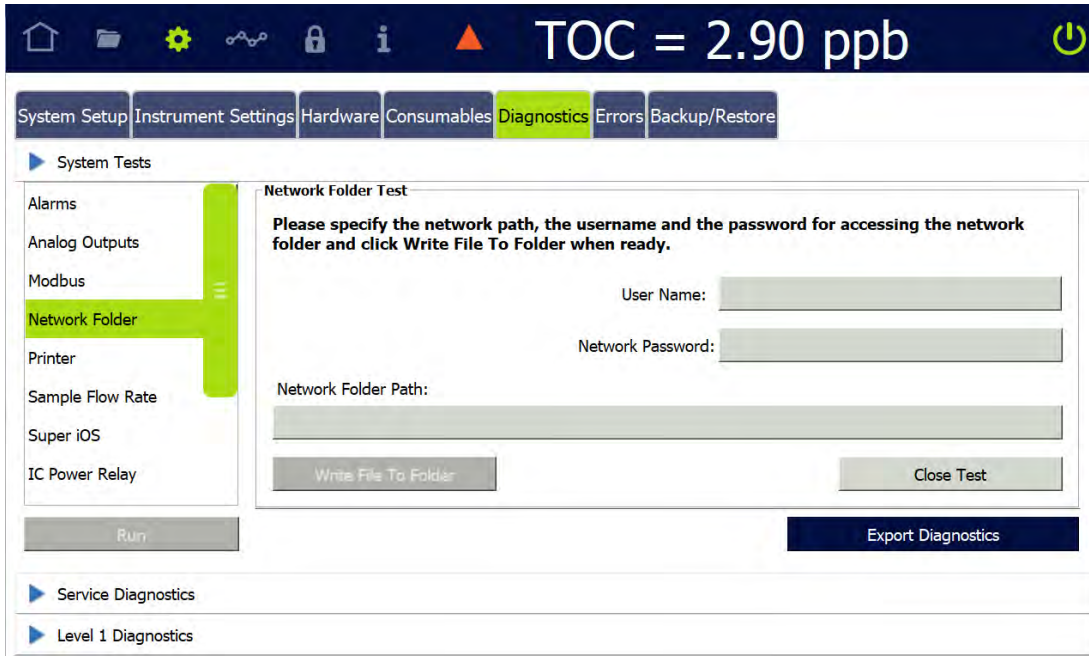

1. Select the *User Name*, *Network Password*, and *Network Folder Path* fields to display an alphanumeric keypad for entering the information in each field.
2. When all network information has been entered, press **Write File to Folder** to send a test file to the location. If the test was successful, the following dialog box will appear:

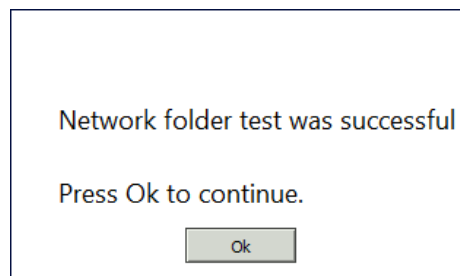

3. Press **OK**, then **CLOSE TEST** to exit the screen.

Printer

Use this test to verify connectivity with a printer attached to the Analyzer. From the *Diagnostics* tab, select *Printer* and press **RUN** to print a “Print Test” message to the printer.

Sample Flow Rate

Use this test to verify functionality of the Sample Pump. From the *Diagnostics* tab, select *Sample Flow Rate* and press **RUN** to display the *Sample Flow Rate Test*:

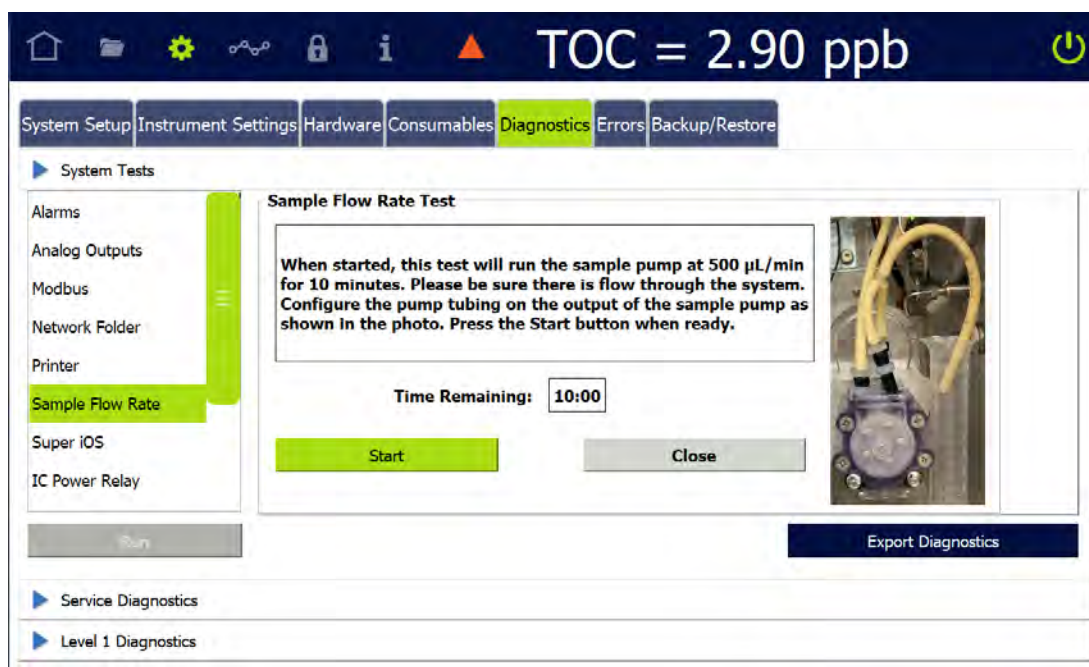

1. Follow the on-screen instructions, then press **START** to begin the test. The status of the test is displayed:
2. When the test completes, follow the on-screen instructions to reconnect the sample pump tubing, then press **CLOSE** to exit the screen.

Super iOS

Run the Super iOS diagnostic to:

- Confirm that the rotary valve is functioning at all five positions in the Super iOS.
- Confirm that the Analyzer can read vial set data from a Super iOS cartridge.

Testing the Super iOS

From the *Diagnostics* tab, select *Super iOS* and press **RUN** to display the *Super iOS Test*:

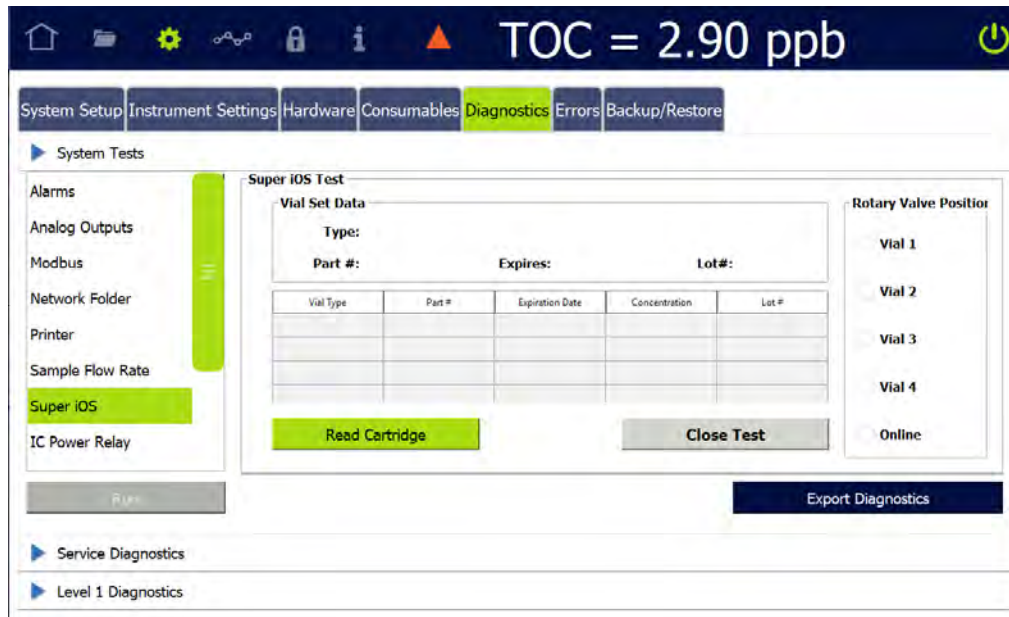

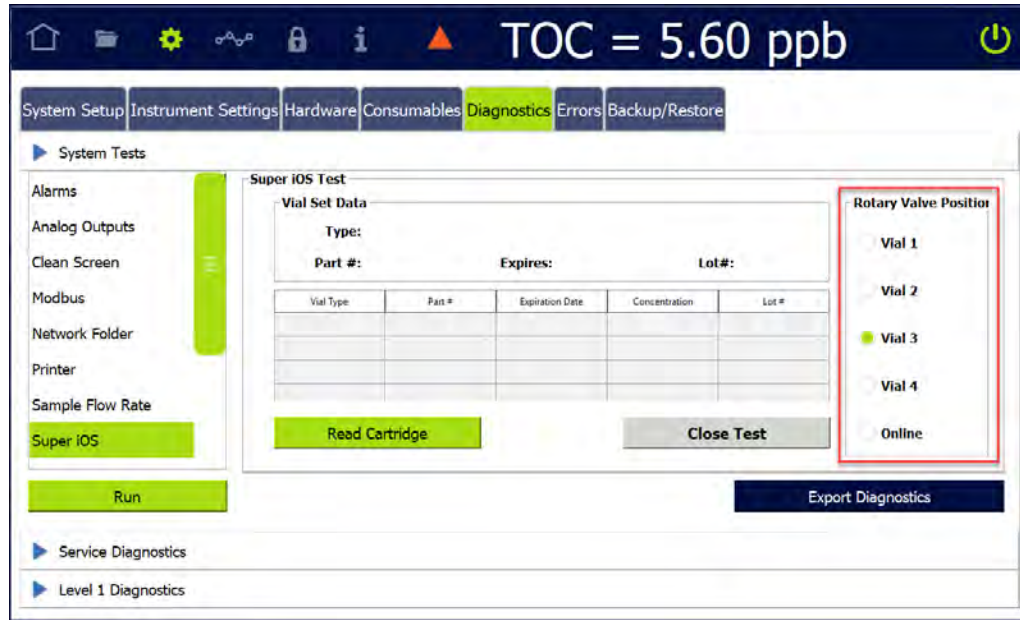

To confirm valve functionality

1. Insert a vial of low-TOC water into the port you want to check.
2. Select *System Tests* > *Super iOS*, then select the Rotary Valve Position for the vial port that contains the vial. You should be able to hear the movement of the valve as it aligns to the selected position.



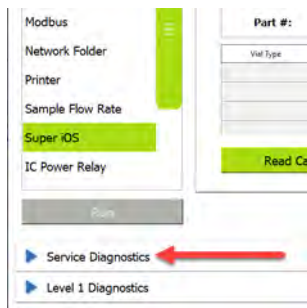

3. Select *Service Diagnostics*.

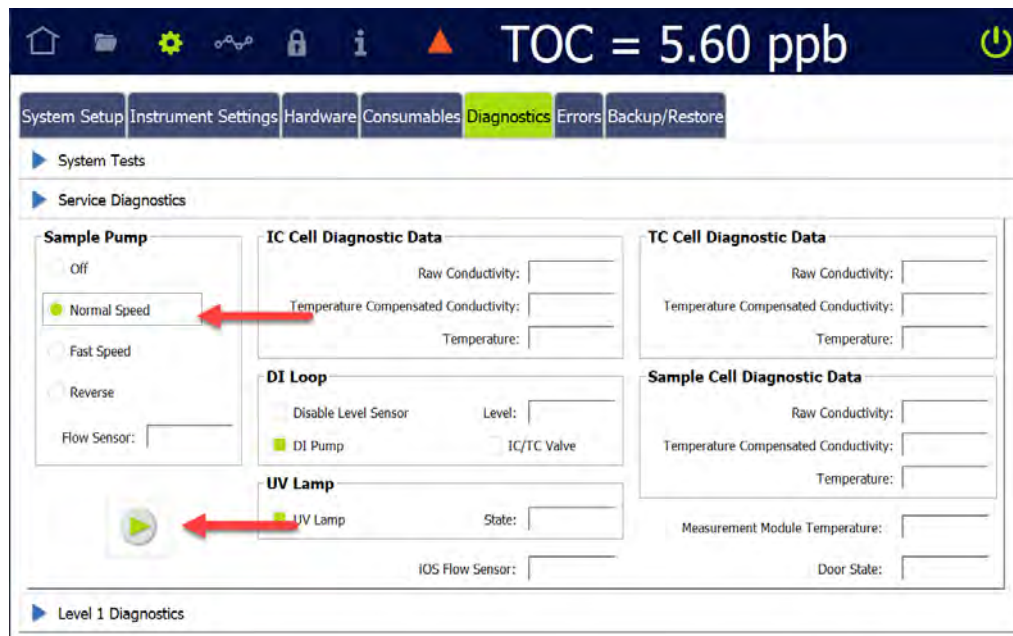

4. Under *Sample Pump*, select *Normal Speed* and press **START**  to turn on the Sample Pump.

Chapter 7 TROUBLESHOOTING



5. Verify that the valve is operating correctly by confirming that air is bubbling into the vial.
6. Repeat steps [1](#) through [5](#) for each of the Rotary Valve Positions.
7. When all positions have been tested, return to *Service Diagnostics*. Under *Sample Pump*, select *Off*. Then press **STOP** .

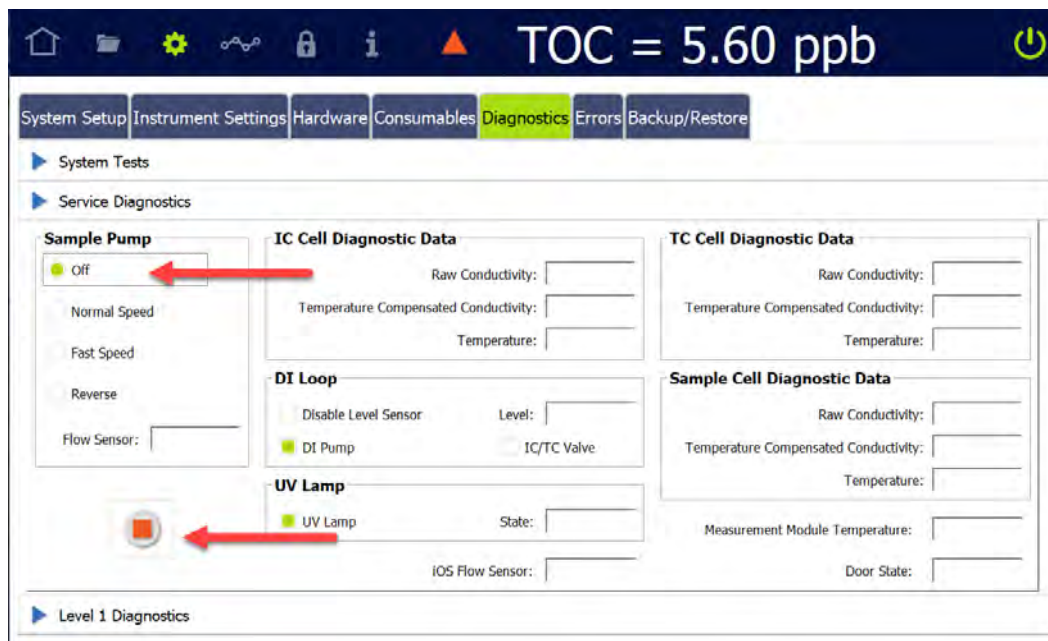

8. Return to *System Tests* and press **CLOSE TEST** to exit the screen.

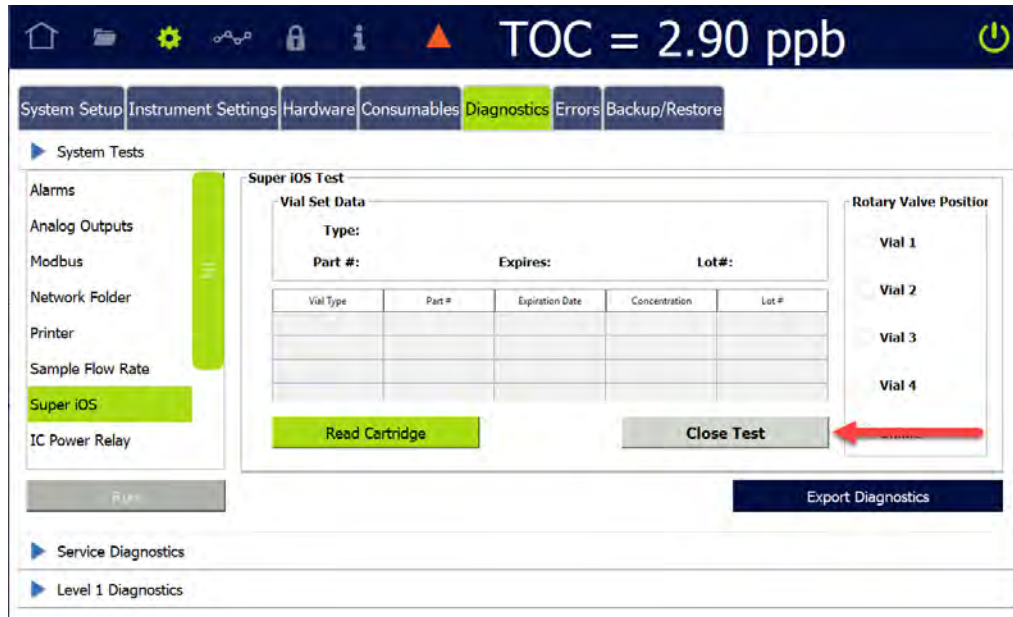

To confirm cartridge functionality

1. Insert a compatible cartridge of any type into the Super iOS and press **READ CARTRIDGE**.

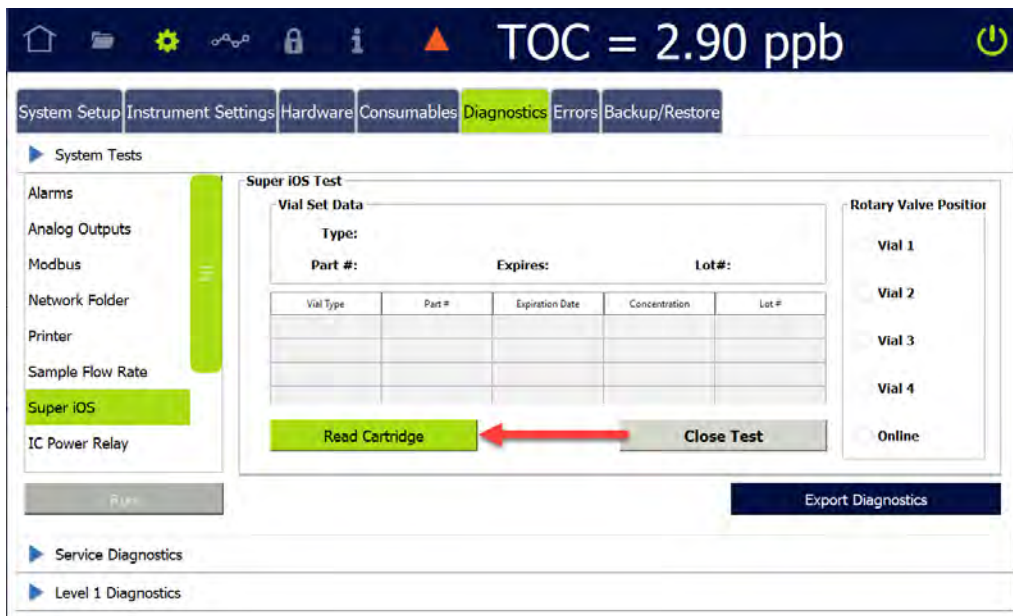

2. Press **CLOSE TEST** to exit the screen.

IC Power Relay

Use this test to verify the functionality of the 24v power control relay for the instrument controller (IC). From the *Diagnostics* tab, select *IC Power Relay* and press **RUN** to display a dialog box with further test instructions:

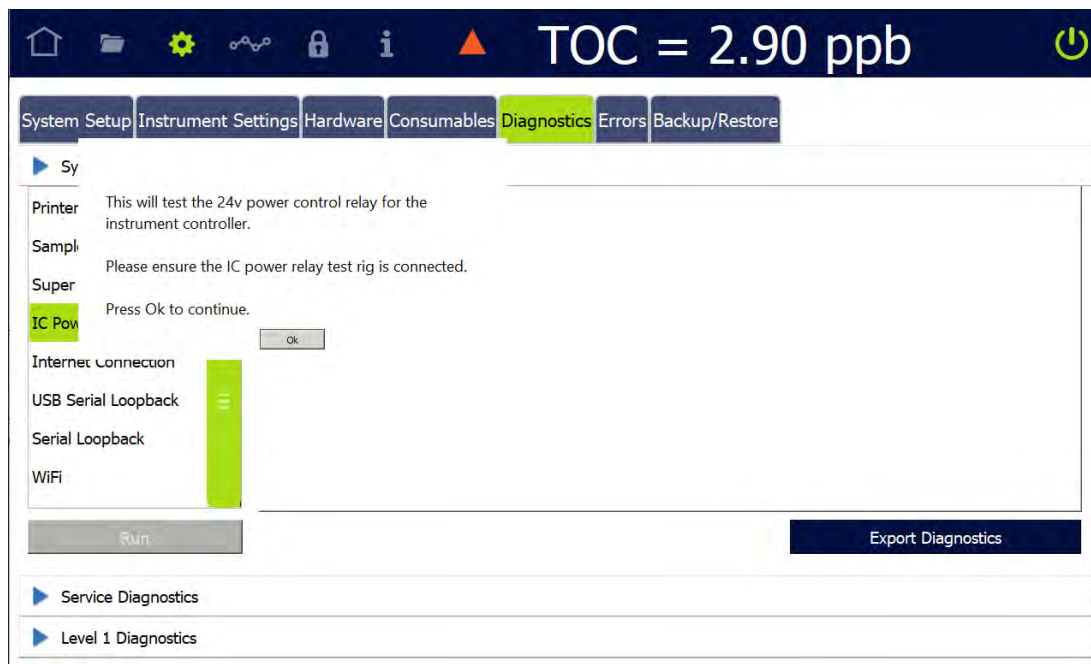

Follow the on-screen instructions. When the test is complete, press **OK** to exit the screen.

Internet Connection

Use this test to verify connectivity from the Analyzer to the Internet. From the *Diagnostics* tab, select *Internet Connection* and press **RUN** to test connectivity. The results of the test are displayed. Press **OK** to close the screen.

USB Serial Loopback

Use this test to verify the functionality of the USB ports with serial loopback. From the *Diagnostics* tab, select *USB Serial Loopback* and press **RUN** to display a dialog box with further test instructions:

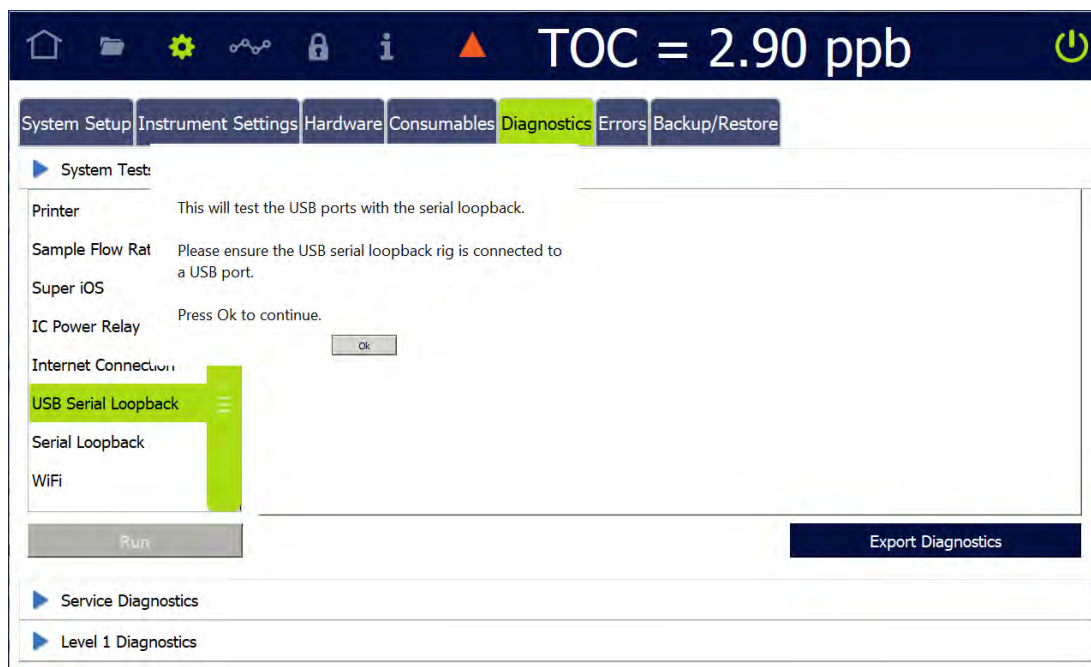

Follow the on-screen instructions. When the test is complete, press **OK** to exit the screen.

Serial Loopback

Use this test to verify the functionality of the serial UART with the serial loopback. From the *Diagnostics* tab, select *Serial Loopback* and press **RUN** to display a dialog box with further test instructions:

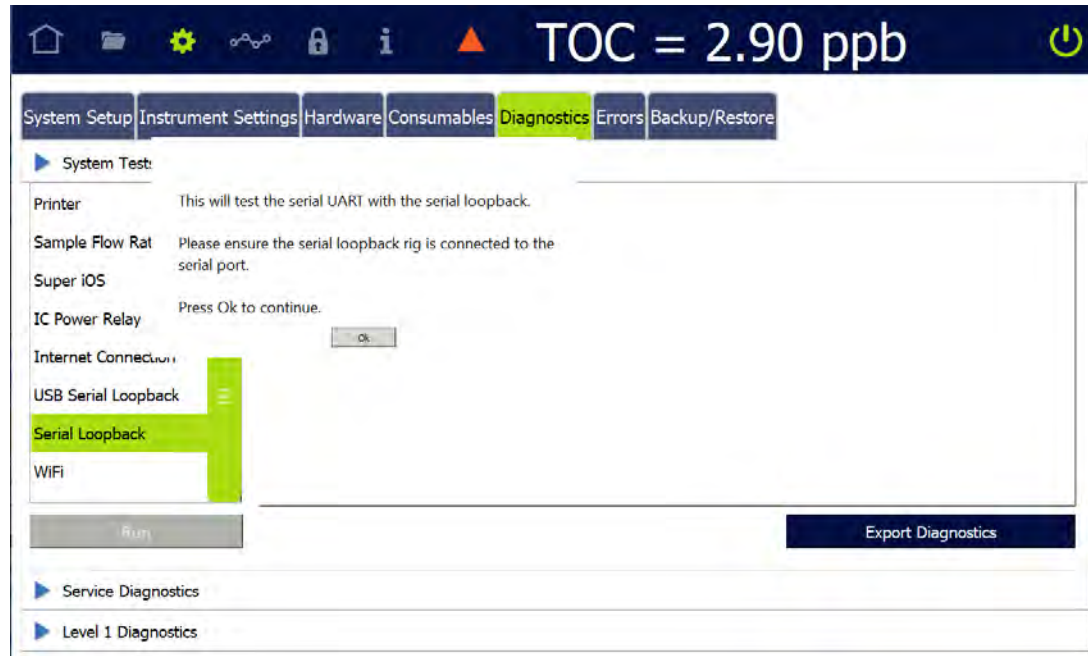

Follow the on-screen instructions. When the test is complete, press **OK** to exit the screen.

WiFi

Use this test to verify functionality of the Analyzer's WiFi connectivity and PCIE adapter. From the *Diagnostics* tab, select *WiFi* and press **RUN** to test connectivity. The results of the test are displayed. Press **OK** to close the screen.

Export Diagnostics



From the *Diagnostics* tab, press **EXPORT DIAGNOSTICS** to export Service Data to a USB device or network folder.

1. Choose the information to export by selecting the check box next to each data type to be included (or select *Export All*).
2. Choose the destination for the export file. Select *USB* or *Network Folder*, then press **SET PATH** to display an alphanumeric keypad to enter the destination directory.
3. Press **OK** to accept the destination.
4. Press **START EXPORT** to export the data. A progress bar shows the status of the export.
5. When exporting is complete, you can now share this information with Technical Support or your local service provider for further troubleshooting of the Analyzer.

SERVICE DIAGNOSTICS

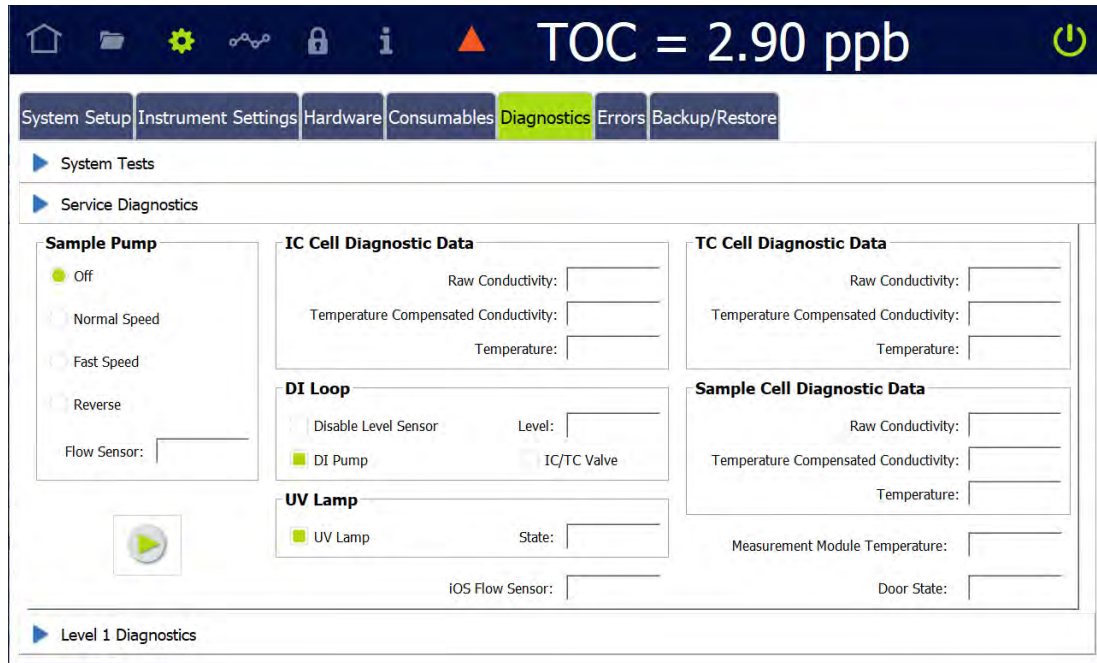
The Service Diagnostics module displays diagnostic data and/or tests functionality of the Sample Pump, IC/TC Cells, Sample Cell, DI Loop, UV Lamp, iOS Flow Sensor, Measurement Module Temperature, and Door State:



1. Select a Sample Pump speed.
2. Select DI Loop options:
 - Disable Level Sensor
 - DI Pump
 - IC/TC Valve
3. Select UV Lamp on/off.
4. Press **START ANALYSIS** .
5. Press **STOP ANALYSIS**  when you are ready to end the test.

LEVEL 1 DIAGNOSTICS

The Level 1 Diagnostics module displays IC/TC temperature and conductivity measurements gathered during normal Analyzer operation:

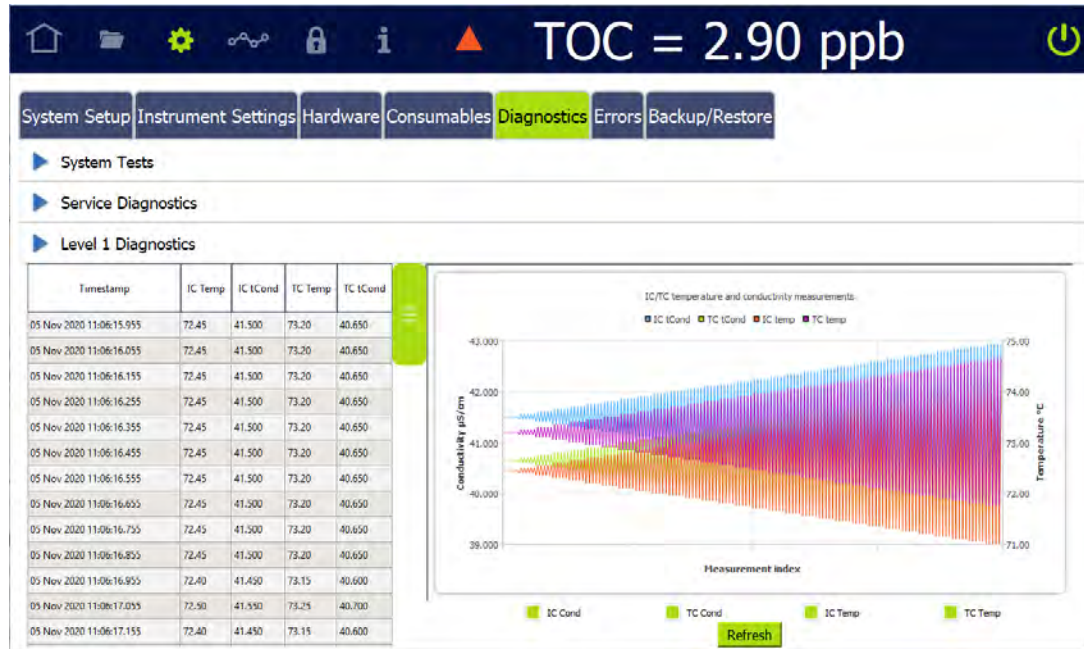

Filter the graph data by selecting and de-selecting the IC Cond, TC Cond, IC Temp, and TC Temp filters.

STEP 4: CONTACT TECHNICAL SUPPORT

After pursuing "[Step 1: Visual Inspection](#)" on page 367 through "[Step 3: Review Solutions for Basic Problems](#)" on page 376, contact Technical Support or your local service provider. When calling, please have basic Analyzer information from the Help screen.

STEP 5: RETURN THE ANALYZER TO SUEZ



In some instances, after consulting with Technical Support or your local service provider, it will be necessary to return the Analyzer to the factory for repairs. *Only return the Analyzer to SUEZ if Technical Support or your local service provider has issued a Return Authorization (RA) number.*

Several precautions must be followed to ensure that the Analyzer is not damaged during shipment. If the original shipping container has not been retained, contact Technical Support or your local service provider to order shipping supplies. *Under no circumstances should the Analyzer be packed in anything other than the original shipping container.*

Before repackaging, water must be drained from the Analyzer.

To prepare Analyzer for shipping

DRAINING THE SAMPLE SIDE

1. If the Analyzer is taking measurements, press **STOP ANALYSIS** .
2. From the *Settings*  screen, select the *Hardware* tab, then *Drain Instrument*.

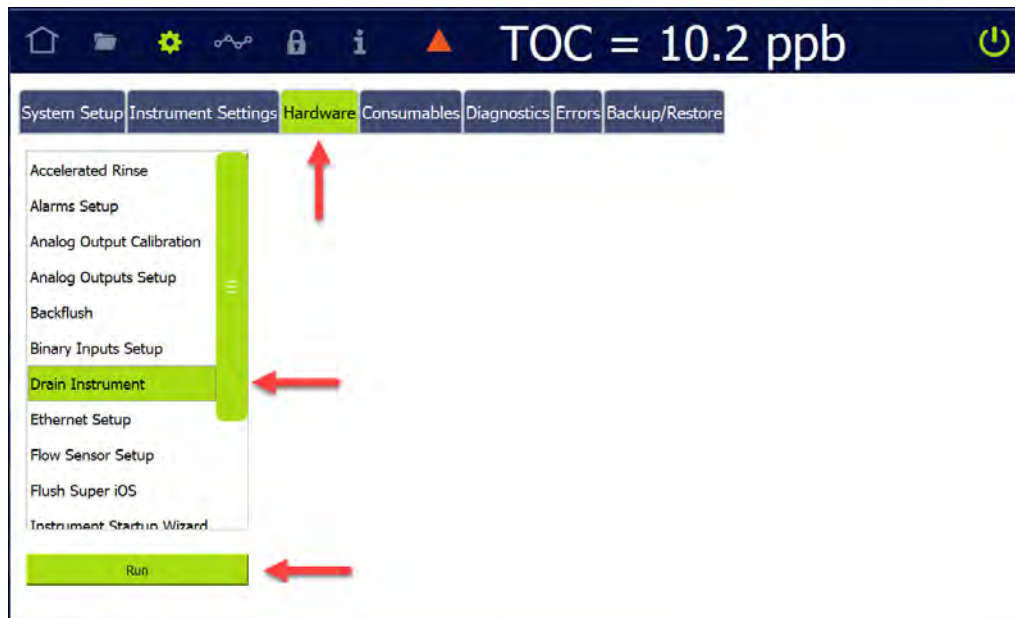

2.1 Select *Drain Sample Side* (do not select *Drain DI Loop* at this time).

2.2 Press **NEXT**.

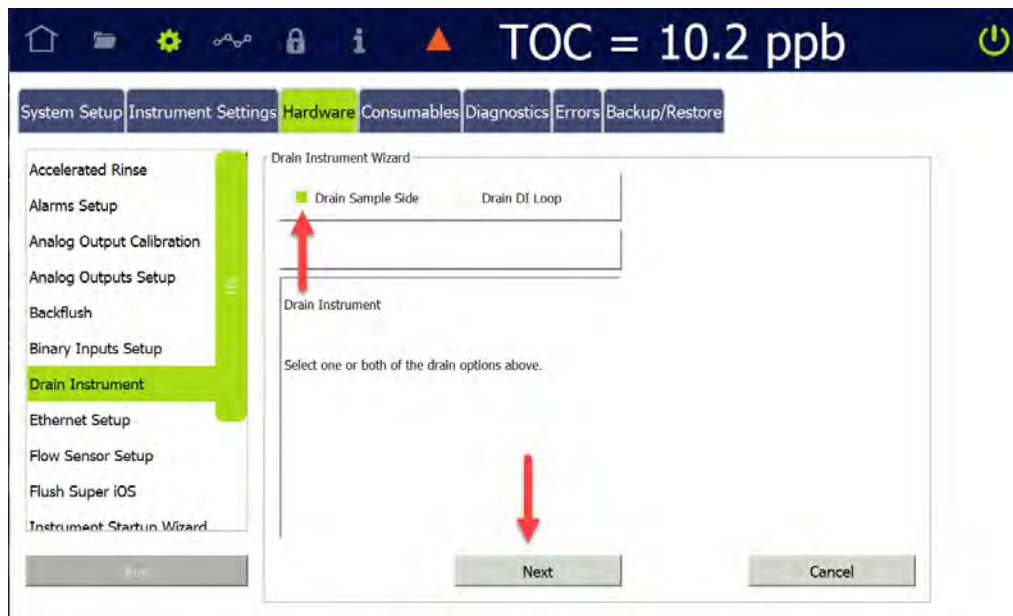

2.3 Ensure that the sample flow to the instrument is shut off and press **NEXT**.

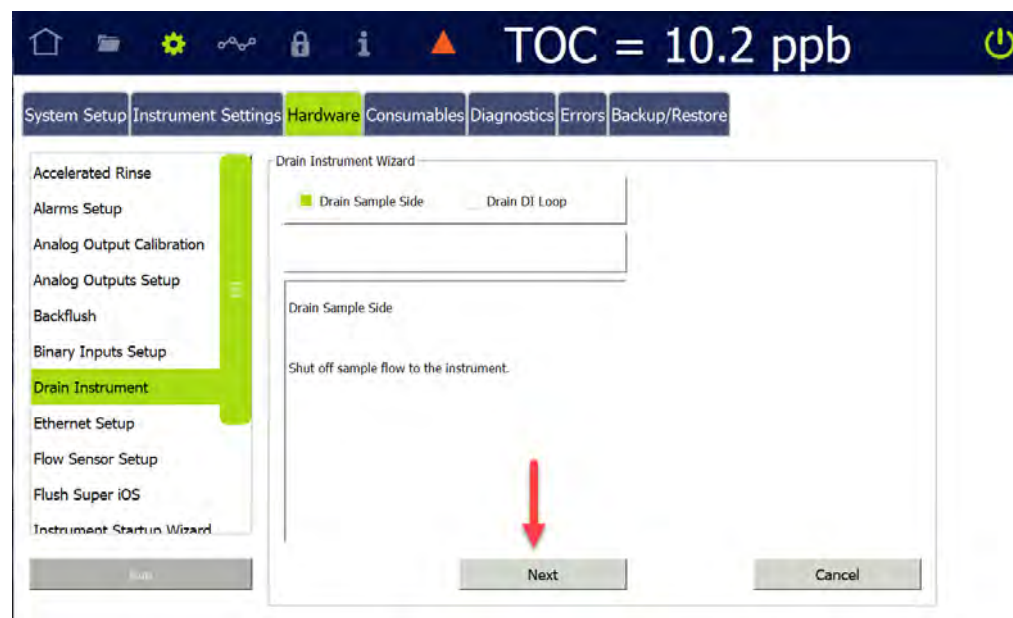

Chapter 7 TROUBLESHOOTING

- 2.4 Wait for the drain process to complete (approximately 3 minutes).
- 2.5 When the screen says “Draining the sample side is complete,” press **NEXT**, then **CLOSE**.
- 2.6 In the *Hardware* tab, select *Flow Sensor Setup*.
- 2.7 Press **NEXT**.

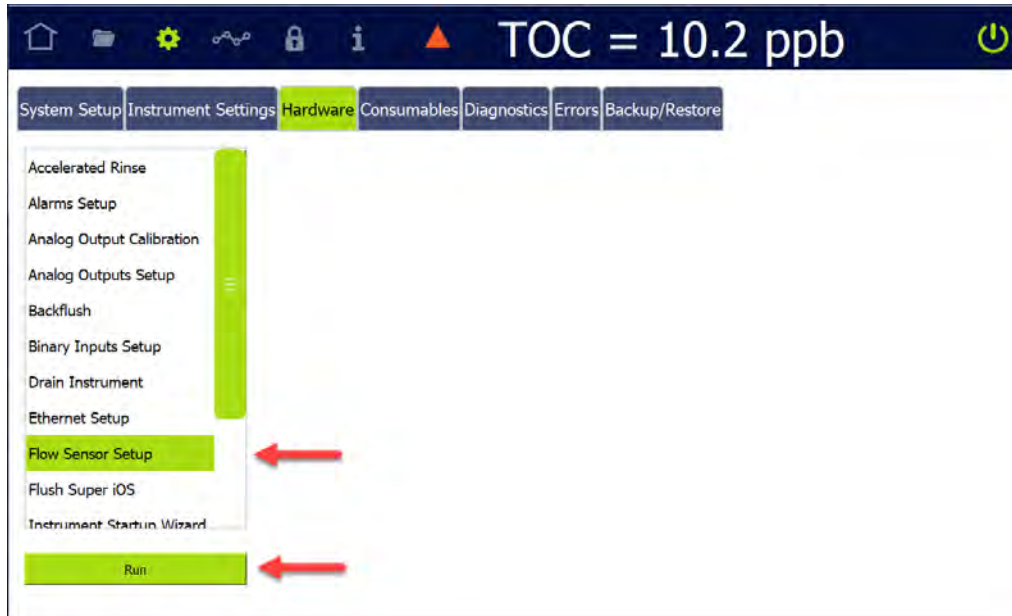

- 2.8 Ensure that the Enable Flow Sensor option is disabled (unchecked) and press **SAVE**.

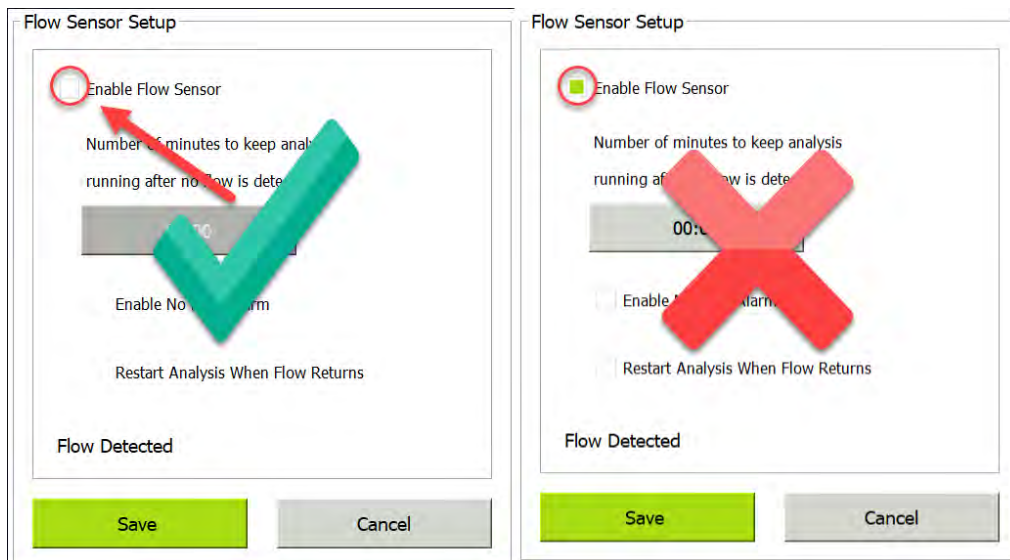

- 2.9 On the *Protocols* screen, select the User Defined Methods tab.

- 2.10 Verify that the *Measurement Mode* is set to *Online*; if not, select *Online Method* from the list of user-defined methods.

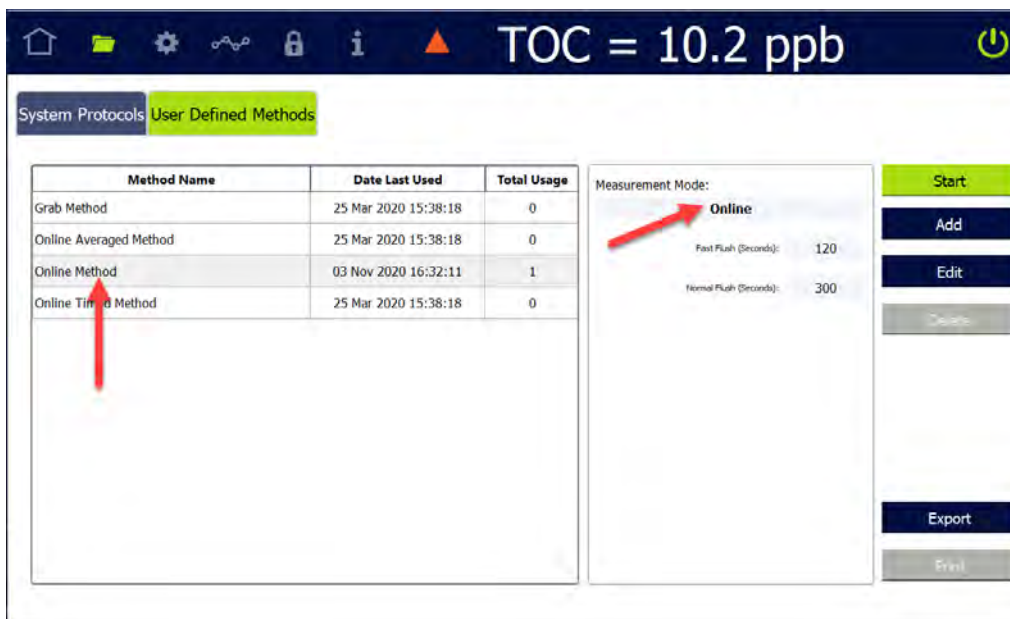

- 2.11 Press **START** to begin analysis. When the waste tubing is full of air, press **STOP ANALYSIS**. In the dialog box that appears, confirm this action.

Chapter 7 TROUBLESHOOTING

- 2.12 Power off the Analyzer by pressing the **POWER OFF** button  in the upper-right corner of the screen. On the dialog box that appears, confirm this choice by pressing **YES**.
- 2.13 When the Analyzer screen goes black, turn the Analyzer power switch left to the *Off* position.
- 2.14 Unplug the Analyzer from its power source.

DRAINING THE DI LOOP

1. Confirm that the Analyzer is powered off and unplugged, and no other cables are attached.
2. Detach the resin cartridge by depressing the release buttons on the DI Loop fittings, then drain the resin cartridge by removing the C-clips and fittings from both ends.



NOTE: The resin cartridge is likely to leak water when it is removed; use a cloth or paper towel to clean any spilled water.

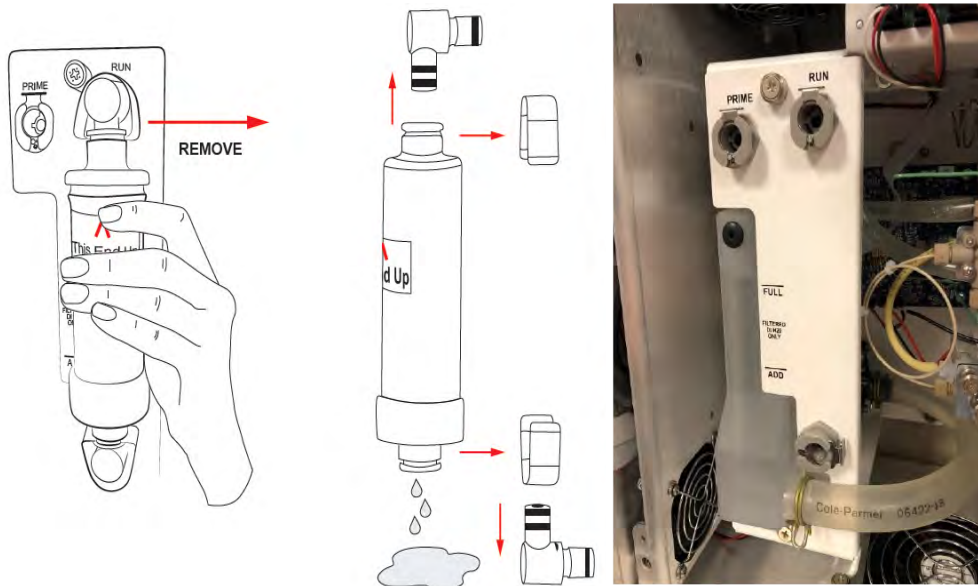

- Retrieve the bulb pump from inside the Analyzer door and attach it to the **RUN** position fitting.



- Squeeze and release the bulb several times to pump the excess water from the measurement module.

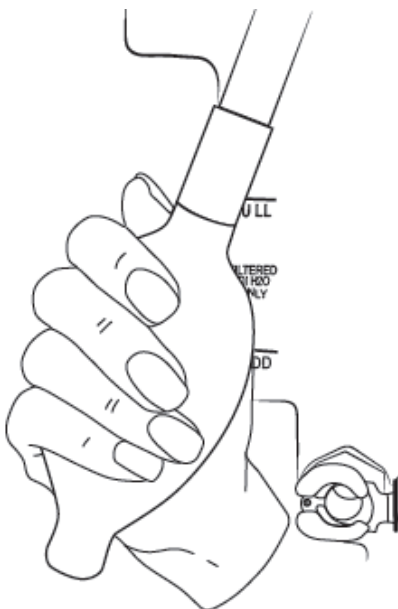

- Retrieve the drain tube from inside the Analyzer door, place the free end into a waste container (1) (e.g., a 500 mL beaker), then attach the fitting to the resin cartridge inlet (2).

Chapter 7 TROUBLESHOOTING

6. Move the bulb pump from the **RUN** fitting to the **PRIME** fitting (3) and hand pump 12 to 15 times to clear the reservoir and DI pump of as much water as possible. Some residual water in the reservoir or tubes is acceptable.

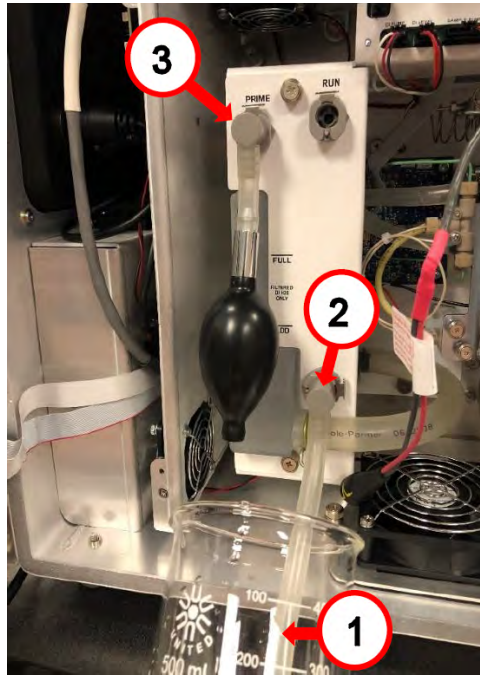

7. Disconnect the bulb pump and drain tubes and return them to their clips inside the Analyzer door.
8. Disconnect the waste tubing and sample inlet tubing from the Analyzer.
9. Disconnect any printer, alarm analog output, or computer cables.
10. Disconnect the power connection to the Analyzer (see note below).
11. Disconnect any alarm or 4-20 mA connections to the Analyzer's terminal block.



NOTE: A qualified electrician may be needed to help detach the wiring (both power and accessories) from the terminal block inside the Analyzer.

12. Close and latch the Analyzer front panel.

The Analyzer is now ready to be packaged and shipped to SUEZ.

For international shipments, coordinate with Technical Support or your local service provider to ensure streamlined passage through customs.

8

MAINTENANCE

Replacing Consumables and Maintenance Items

To ensure optimum performance of the Analyzer, routinely replace Analyzer consumables and maintenance items. Refer to [Table 22, “Replacement Schedule for Consumables.” on page 408](#) for the recommended maintenance schedule. The in-line filter, UV lamp, resin cartridge, and sample pump heads must be purchased from SUEZ.

When replacing items that affect analysis, such as the UV lamp, resin cartridge, or pump heads, perform a verification of the calibration. Only re-calibrate if verification indicates that a new calibration is necessary.

For additional assistance, contact SUEZ Technical Support or your local service provider. Training is also available from SUEZ.

This chapter covers replacement instructions for all routine maintenance items that are replaced on a regular schedule; instructions for non-routine maintenance items are provided in those items’ packaging.

A one-year maintenance record log is provided for convenience to ensure that all required maintenance is performed when necessary (see [Table 16, “Sievers M500 TOC Analyzer 3-Year Maintenance Worksheet.” on page 421](#)).

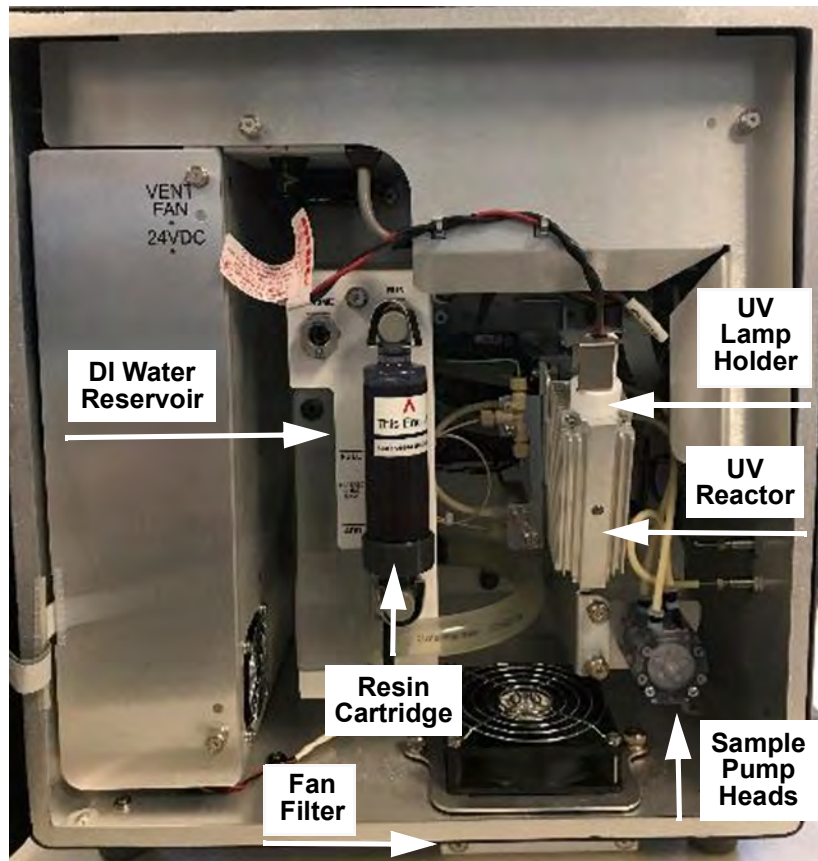

Figure 17: Interior Overview of the Analyzer

Table 22: Replacement Schedule for Consumables



<i>Description</i>	<i>Typical Operating Life</i>
DI Water Level	6 months (Also check when replacing other items, and refill as needed)
UV Lamp	6 months
Fan Filter	6 months
Sample Pump Heads	12 months
Resin Cartridge	Typically 24 Months (depending on water quality)
In-line Filter	Replace as Needed (depending on water quality)

Verifying the DI Water Level

Verify the DI Water level periodically and refill, if needed.



To check the water level in the DI water reservoir

1. If the Analyzer is taking measurements, press the **STOP ANALYSIS**  button.
2. On the Analyzer's *Home* screen, press the **POWER OFF**  button to close all the files.
3. Turn the rotary power switch (located on the left outside panel of the Analyzer) to the *Off* position to complete the power off cycle.
4. Open the door to the Analyzer.
5. Locate the DI water reservoir. (See [Figure 17](#) on [page 408](#)).
6. If the water level is below the *Full* line, add DI water to the reservoir, as instructed in the next section, ["To fill the DI water reservoir" on page 409](#).

To fill the DI water reservoir

1. Continue from the previous section [To check the water level in the DI water reservoir](#).
2. Locate the dispensing bottle in the Analyzer's Accessories Kit.
3. Have a paper towel nearby, in case of any leakage during the installation process.
4. Unscrew the lid of the dispensing bottle and fill the bottle with low-TOC DI water. Replace and tighten the lid to secure it.
5. Remove the rubber stopper from the top of DI reservoir. Save the rubber stopper to reinsert at the end of the fill process.



6. Insert the tip of the bottle into the hole and squeeze the bottle to fill the DI reservoir until the water line reaches the FULL line, indicated on the outside of the reservoir.
7. Re-insert the rubber stopper into the top of the DI reservoir.
8. Close and latch the door to the Analyzer case.
9. Re-establish power to the Analyzer. It is not necessary to prime the DI water pump for this procedure.

Replacing the UV Lamp

The intensity of the UV lamp, particularly the emission of short-wavelength radiation, decreases over time. Replace the lamp after every six months of operation.



Hazardous Material Disposal

The UV lamp contains mercury and may be considered hazardous material in your local area. Dispose of these items in accordance with federal, state, or local government regulations.

Hazardous Material Disposal

In the case of any broken or damaged UV lamp, handle the remains in accordance with your organization's toxic waste handling procedure and dispose of them in accordance with federal, state, or local government regulations.



Warning

	To avoid potentially dangerous shock, BEFORE opening the Analyzer, stop any analysis and power off the operating system. Press the Power On/Off  button in the Analyzer's firmware, then turn <i>off</i> the power switch and disconnect from the power supply. Any operation requiring access to the inside of the Analyzer without turning off power, including installation of maintenance items, could result in injury.
	RISK GROUP 3 Warning: UV emitted from this product. Avoid eye and skin exposure to unshielded product.



NOTE: A cotton glove for wearing during the installation is included with the replacement UV lamp to avoid leaving fingerprints on the quartz window of the lamp. Fingerprints absorb UV radiation and decrease the performance of the oxidation reactor. If necessary, use methanol to remove any fingerprints before installing the new lamp.

To replace the UV lamp

1. If the Analyzer is taking measurements, press the **STOP ANALYSIS**  button.
2. On the Analyzer's *Home* screen, press the **POWER OFF**  button to close all the files.
3. Turn the rotary power switch (located on the left outside panel of the Analyzer) to the *Off* position to complete the power off cycle.
4. Open the Analyzer's door to access the inside of the Analyzer.
5. Locate the UV lamp enclosure at the right of the Analyzer ([Figure 17 on page 408](#)). The UV lamp has a red and black wire with a black connector extending from the UV Lamp Holder.
6. Disconnect the black power connector from the bulkhead connector by turning the connector and then carefully pulling the two halves of the plug apart.
7. Slowly slide the UV lamp out of the enclosure.

Chapter 8 MAINTENANCE

- Put on the glove provided with the new UV lamp, to avoid leaving fingerprints on the quartz bulb of the lamp.
- Remove the new lamp from the packet.
- Carefully slide the lamp assembly into the enclosure. Stop if feeling any resistance and realign the lamp in the reactor.



NOTE: This photo is for illustration only. The Holder is removed from its installed position. Insert the UV Lamp into the Holder on the UV Reactor.

- Connect the power connector to the bulkhead connector by aligning yellow lines and pushing firmly until the locking mechanism clicks. Gently pull on the power connector to make sure it is securely attached to the power supply.
- Record the installation date for the lamp in the service log ([Table 16 on page 421](#)).
- If planning to replace other consumables, follow the procedures listed in the appropriate sections of this chapter. Otherwise, close and latch the Analyzer door.
- Re-establish power to the Analyzer.
- Enter the installation date for the UV lamp by following the procedures in [“Entering New Consumables Installation Dates” on page 419](#).
- After changing the UV lamp, perform a TOC verification. Refer to [“Accuracy & Precision Verification Protocol” on page 270](#)). Only re-calibrate if verification indicates that a new calibration is necessary.

Replacing the Sample Pump Heads

The tubing for the sample pump heads loses elasticity over time and the sample pump heads must be replaced annually to ensure proper flow rates. The pump heads must be purchased from SUEZ.



Warning



To avoid potentially dangerous shock, BEFORE opening the Analyzer, stop any analysis and power off the operating system. Press the Power On/Off  button in the Analyzer's firmware, then turn *off* the power switch and disconnect from the power supply. Any operation requiring access to the inside of the Analyzer without turning off power, including installation of maintenance items, could result in injury.

Have paper towels available during the procedure in case water leaks from the old pump heads during the removal process. Reference the [Figure 17 on page 408](#), as needed.

To replace the sample pump heads

1. If the Analyzer is taking measurements, press the **STOP ANALYSIS**  button.
2. Shut off the water to the sample inlet system.
3. On the Analyzer's *Home* screen, press the **POWER OFF**  button to close all the files.
4. Turn the rotary power switch (located on the left outside panel of the Analyzer) to the *Off* position to complete the power off cycle.
5. Open the door to access the inside of the Analyzer.
6. Locate the sample pump heads (see [Figure on page 408](#)).
7. Remove the tubing leading to and from the pump heads from the four barbs.
8. Use a small Phillips-head (crosshead) screwdriver (from the Accessories kit) to loosen the two screws that secure the pump heads. Remove the screws and retain them.
9. Pull both pump heads straight out and off the shaft. Use a paper towel to clean any dripping that occurs.
10. Dispose of the old pump heads according to local regulations.
11. Remove the new pump heads from the packaging.

- Slide one pump head onto the shaft and push it all the way back, making sure the set pins are seated properly. You may need to “walk” the pump head onto the shaft. The shaft is a “D” and must align properly with the pump heads.
- Slide the second pump head onto the shaft and push it all the way back, making sure the set pins are seated properly.
- Replace and secure the two Phillips-head (crosshead) screws. Do not over tighten to avoid damaging the pump head or motor.

To confirm that the screws are not overtightened, hold the body of the pump head and attempt to move it a few degrees clockwise and counterclockwise. The body of the pump head should still be able to move a slightly. If the pump head body is immobile, then the screws are overtightened.



NOTE: When securing the pump head screws, ensure that the body of the pump head can shift independently from the bridge to allow proper alignment between the screws and the shaft of the motors. This prevents excess strain on the motor by ensuring proper alignment. If the screws are overtightened, the pump head cannot properly shift to align on the motor's shaft.

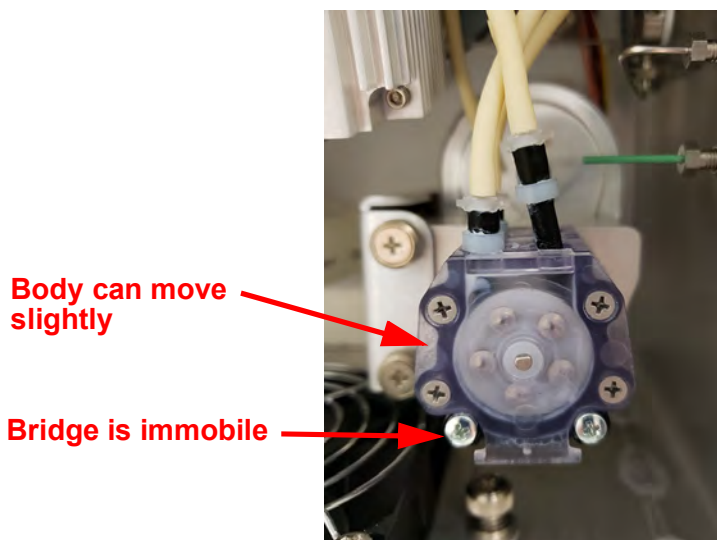

- Reattach the sample pump tubing. Tubing on the left side of the pump head should run to either length of the tubing on the left; tubing on the right side of the pump head should run to either fork of the “Y” tubing.
- Manually record the installation date for the pump heads in the service log ([Table 16 on page 421](#)).
- If replacing other consumables, follow the procedures listed in the appropriate sections of this chapter. Otherwise, close and latch the Analyzer door.
- Restore power to the Analyzer.





19. Enter the installation date for the pump heads in the firmware, as described in [“Entering New Consumables Installation Dates” on page 419](#).
20. Refer to [“Accuracy & Precision Verification Protocol” on page 270](#)). Only recalibrate if verification indicates that a new calibration is necessary.

Replacing the Resin Cartridge

The ion exchange resin cartridge depletes over time. This maintenance process includes installing the resin cartridge into the PRIME position to prepare to prime the DI pump, priming the DI pump, and installing the resin cartridge into the RUN position.

To replace the resin cartridge

1. If the Analyzer is taking measurements, press the **STOP ANALYSIS**  button.
2. On the Analyzer's Home screen, press the **POWER OFF**  button to close all the files.
3. Turn the rotary power switch (located on the left outside panel of the Analyzer) to the *Off* position to complete the power off cycle.
4. Open the door to access the inside of the Analyzer and locate the existing resin cartridge.
5. Remove the installed resin cartridge. Simultaneously press the latches on the *Run* port and the *DI Pump Outlet* port to release the cartridge and pull away. Set aside the resin cartridge for proper disposal according to local area regulations.
6. Install the new resin cartridge. Holding the new resin cartridge with the indicated end up, simultaneously insert one elbow-fitting end of the resin cartridge into the *PRIME* port and the other elbow-fitting end into the *DI pump outlet*.

Verify that the ends are secure before moving to the next step.

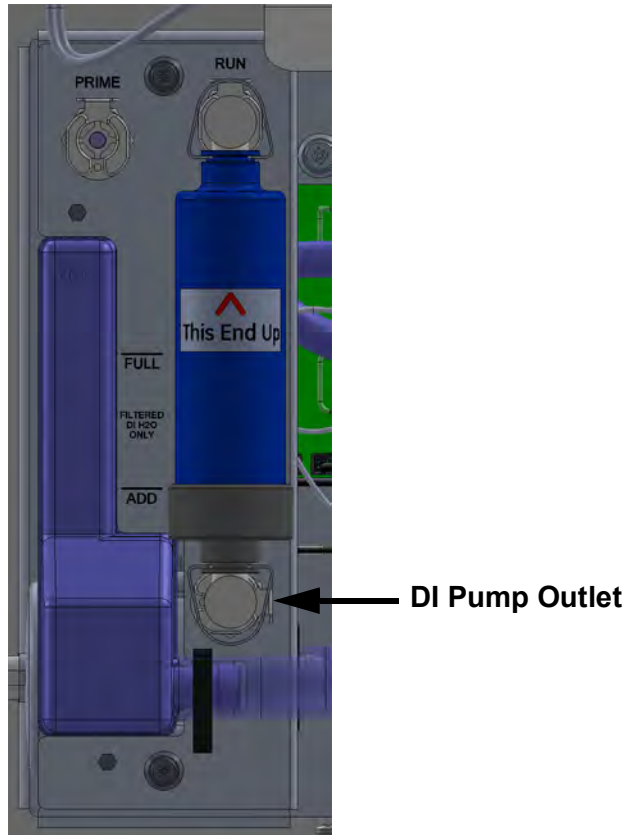

NOTE: Each port (*Prime*, *Run*, and *DI Pump Outlet*) has a metal latch to use when attaching or detaching a fitting. Press the latch with a finger to release a fitting and close the valve. When inserting or detaching the resin cartridge, insert or detach both end-fittings simultaneously to avoid damaging the cartridge.

7. Close and latch the door to the Analyzer.
8. Re-establish mains power to the Analyzer and turn the power switch to the *ON* position. This will turn on the DI water pump. Let the Analyzer run for 30 minutes to allow the DI pump to circulate water in the DI Loop.
9. Turn off the Analyzer and open the door to the Analyzer.
10. Check the level of water in the DI water reservoir. If the water level has dropped below the *Full* line, remove the rubber inlet cover from the top of the DI water reservoir, add more DI water, and replace the inlet cover.
11. Remove the resin cartridge from the *PRIME* position. While holding the resin cartridge, simultaneously press the latches on the *PRIME* port and *DI Pump Outlet* port to eject the cartridge.



12. Install the resin cartridge into the *RUN* position. Simultaneously insert one elbow-fitting end of the resin cartridge into the *RUN* port and the other elbow-fitting end into the *DI Pump Outlet* port.
13. Verify that the ends are secure before moving to the next step.
14. Restore power to the Analyzer.
15. Enter the installation date for the resin cartridge in the firmware, as described in [“Entering New Consumables Installation Dates” on page 419](#).
16. Let the Analyzer run for an additional 30 minutes to circulate water in the DI loop.
17. Turn off the Analyzer and open the door to check and troubleshoot any leaks.
18. Restore power to the Analyzer.
19. Refer to [“Accuracy & Precision Verification Protocol” on page 270](#). Only re-calibrate if verification indicates that a new calibration is necessary.



Replacing the In-Line Filter Element

To prevent clogging in online configurations, a filter is installed on the sample inlet line. The lifetime of the filter element depends on the level of particles in the water samples. If monitoring the TOC of the feed water (prior to purification), the filter element will need to be replaced more often than if monitoring the water after purification.

If the filter element clogs too frequently, contact Technical Support or your local service provider to receive help in the selection of larger-capacity filters. As the filter is used, the flow rate of water through the iOS System will decrease and can even stop. A simple way to determine if the filter element needs to be changed is to periodically measure the flow rate of water out the waste line from the iOS System and replace the filter element when the flow rate starts to decrease.

Replace the filter element on a routine basis to prevent clogging.

To replace the filter element

1. If the Analyzer is taking measurements, press the **STOP ANALYSIS**  button.
2. Shut off the water to the sample inlet system.
3. On the Analyzer's Home screen, press the **POWER OFF**  button to close all the files.
4. Turn the rotary power switch (located on the left outside panel of the Analyzer) to the *Off* position to complete the power off cycle.
5. Open the door to access the inside of the Analyzer.

Chapter 8 MAINTENANCE

6. Remove the filter by loosening the nuts on the 1/4" Teflon tubing and disconnecting the tubing.
7. Position the 3/4" wrenches on the ends of the filter. Loosen the adapter on the inlet side of the filter.

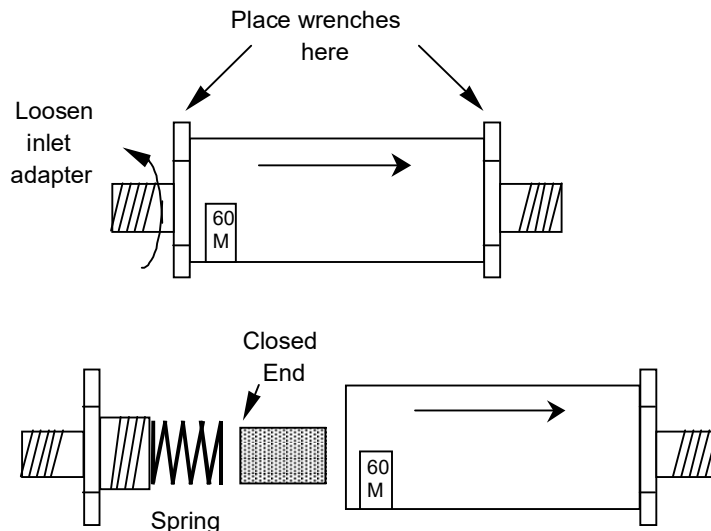

8. Unscrew the spring-loaded inlet adapter, taking care not to lose the spring.
9. Remove the old filter element from the body of the filter.
10. Insert a new filter element into the body of the filter, opened end first.
11. Replace the spring in the inlet adapter and screw the inlet adapter into the body of the filter.
12. Secure the inlet adapter by tightening approximately one-quarter turn past finger-tight.
13. Reconnect the 1/4" Teflon tubing from the sampling port adapter to the inlet of the in-line filter. The in-line filter has arrows on the body of the filter that indicate the direction of flow through the filter. Tighten the nut one-quarter turn past finger-tight.
14. Reconnect the 1/4" Teflon tubing to the outlet of the filter and tighten the nut one-quarter turn past finger-tight.
15. Turn on the water supply at the sampling port.
16. Re-establish power to the Analyzer.

Replacing the Fan Filter

The fan filter located at the bottom of the Analyzer should be replaced every six months. The filter may also be rinsed out more frequently if needed.

To replace the fan filter

1. Use a Phillips head screwdriver to remove the two screws in the cover plate at the bottom of the Analyzer front. See [Figure 17 on page 408](#). Remove the cover plate.
2. Reach in and extract the filter.
3. Re-install a new filter by sliding it back into place.
4. Re-install the cover and tighten the two screws.

Entering New Consumables Installation Dates

When replacing a consumable, enter the date of installation on the *Consumables* screen to enable the Analyzer to keep an accurate record of usage and issue reminders.

1. On the *Settings* screen, select the *Consumables* tab.

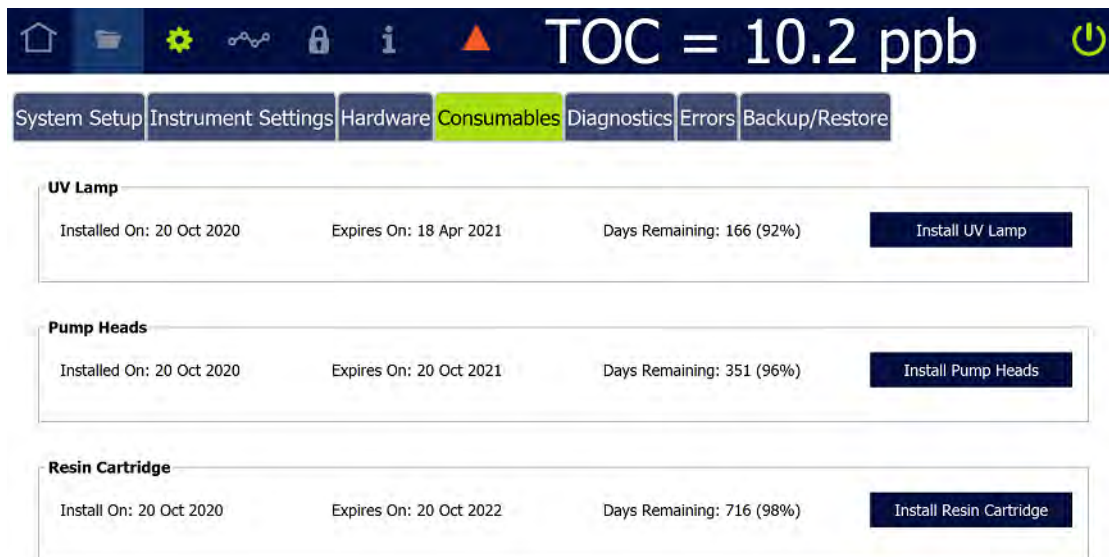

2. In the applicable area (*UV Lamp*, *Pump Tubing*, *Resin Cartridge*), press one of the following buttons to use the calendar for entering the date the consumable was installed. The installation date, applicable expiration date, and number of

days remaining for the life of the consumables automatically appears to the left of the button.



- Install UV Lamp
 - Install Pump Tubing
 - Install Resin Cartridge
3. Repeat the previous step for each consumable replaced.

Cleaning the Analyzer

When replacing consumables, clean the Analyzer's external housing and touchscreen as part of routine preventative-maintenance schedule.

To clean the external housing

Obtain a clean, soft cloth dampened with water or a non-abrasive cleaner, and another clean *dry* soft cloth.

1. If the Analyzer is taking measurements, press the **STOP ANALYSIS**  button.
2. On the Analyzer's Home screen, press the **POWER OFF**  button to close all the files.
3. Turn the rotary power switch (located on the left outside panel of the Analyzer) to the *Off* position to complete the power off cycle.
4. Turn off power to the Analyzer with the main power switch.
5. Wipe the external housing with a clean cloth dampened with water or a non-abrasive cleaner.
6. Wipe dry with another clean and *dry* soft cloth.

To clean the touchscreen

1. Obtain a clean, soft (and *dry*) cloth or cotton pad.
2. Navigate to the *System Tests* panel (*Settings*  screen > *Diagnostics* tab).
3. On the scrolling menu, select *Clean Screen* and press **RUN** to temporarily disable the screen for 30 seconds. Repeat, as needed, if the 30-second time frame expires while cleaning.
4. Wipe the touchscreen with a clean, soft (and dry) cloth or cotton pad.



Table 16: Sievers M500 TOC Analyzer 3-Year Maintenance Worksheet

Item	Period	Installation Date	Notes
UV Lamp	6 months		
DI Water Level*	6 months		
Fan Filter	6 months		
Pump Heads	12 months		
UV Lamp	12 months		
DI Water Level*	12 months		
Fan Filter	12 months		
UV Lamp	18 months		
DI Water Level*	18 months		
Fan Filter	18 months		
Pump Heads	24 months		
UV Lamp	24 months		
Resin Cartridge	24 months		
DI Water Level*	24 months		
Fan Filter	24 months		
UV Lamp	30 months		
DI Water Level*	30 months		
Fan Filter	30 months		
Pump Heads	36 months		
UV Lamp	36 months		
DI Water Level*	36 months		
Fan Filter	36 months		

Chapter 8 MAINTENANCE

**The DI water reservoir level should also be checked and filled, as necessary, as part of every maintenance.*

Analyzer Serial number _____ Date placed into operation _____

Dates of operation encompassed by this worksheet: from _____ to _____



Appendix A: Analyzer Dimensions



ANALYZER DIMENSIONS

Diagrams show Analyzer dimensions and required clearances as follows: inches [millimeters].

Analyzer Configured with Standard iOS

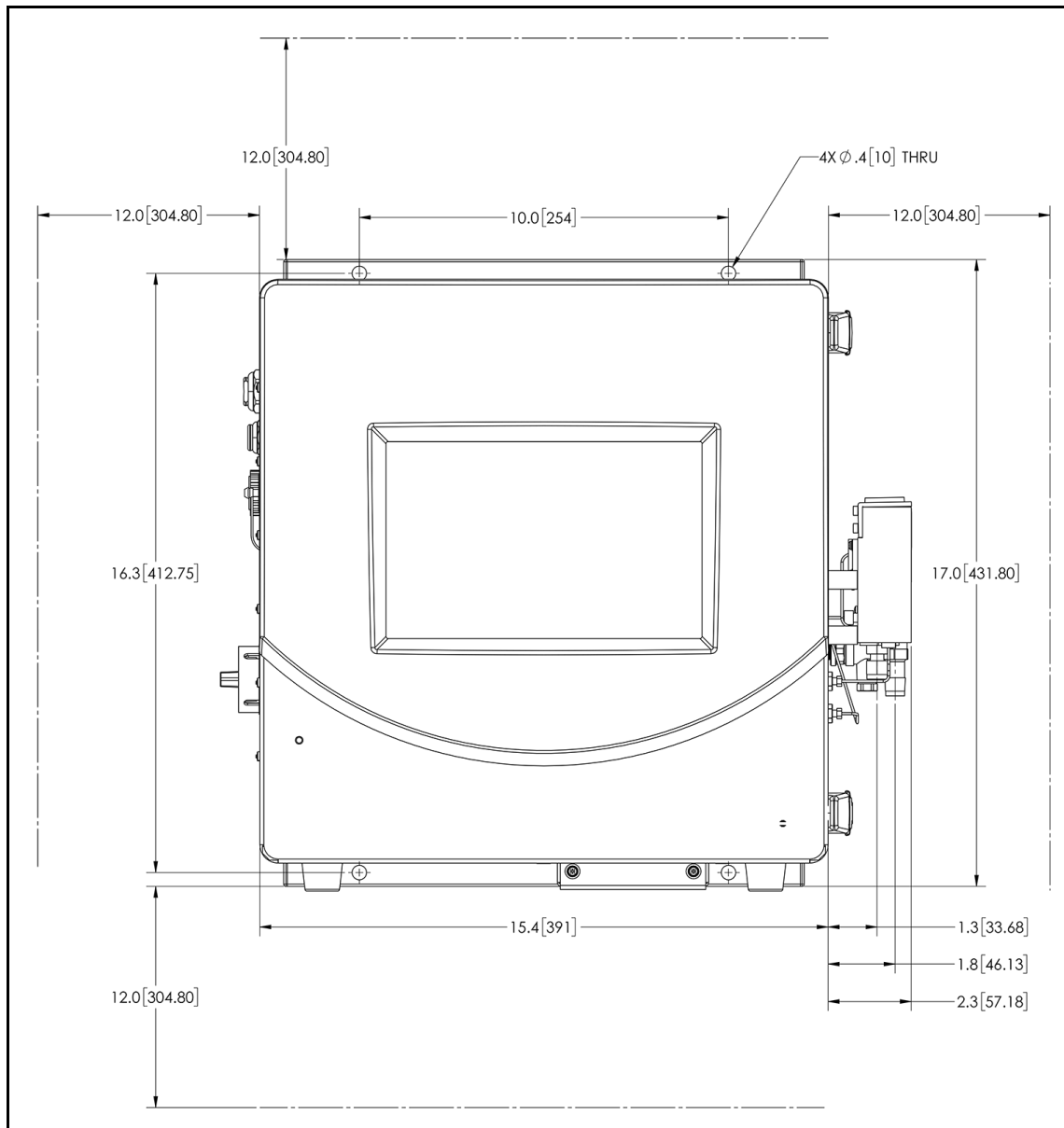

Figure 18: Analyzer Dimensions, with Standard iOS System

ANALYZER CONFIGURED WITH STANDARD IOS

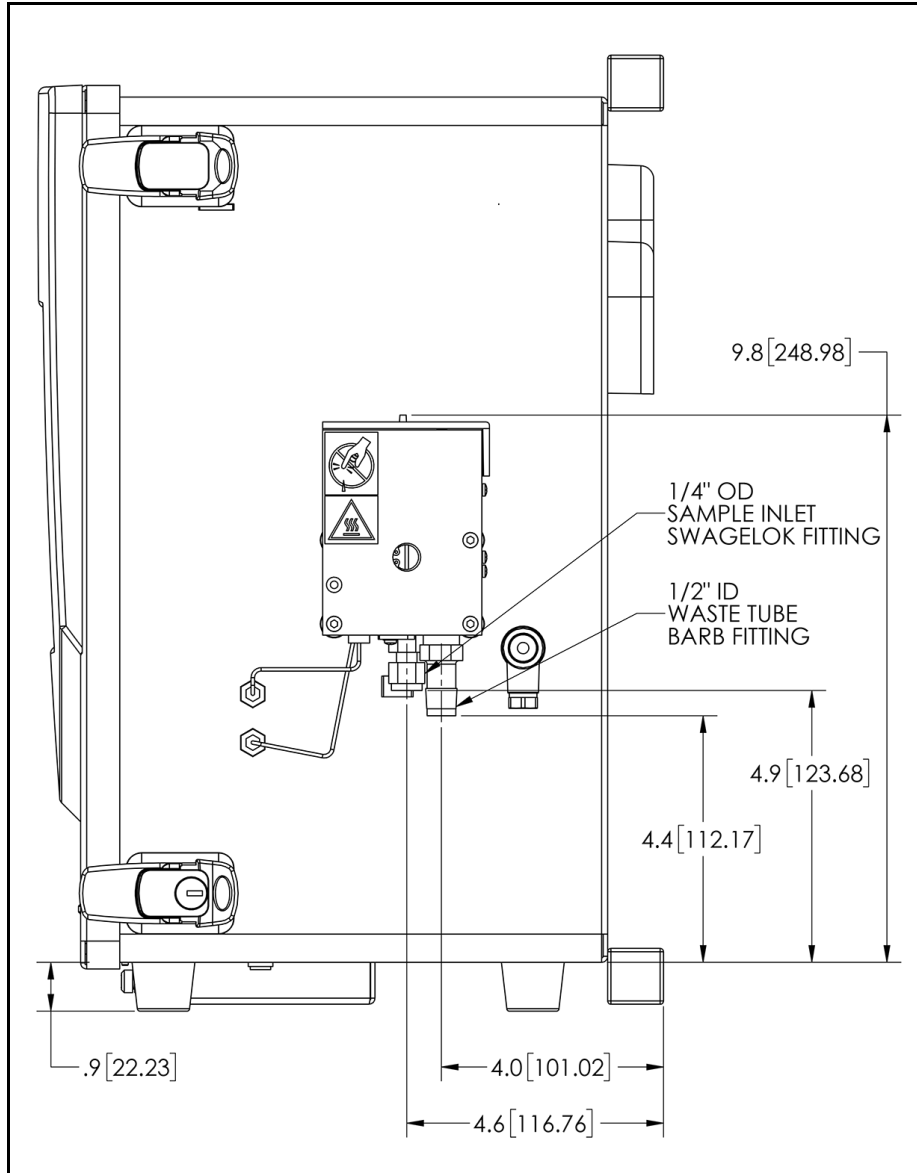

Figure 19: Right-Side Analyzer Dimensions, with Standard iOS System

Appendix A

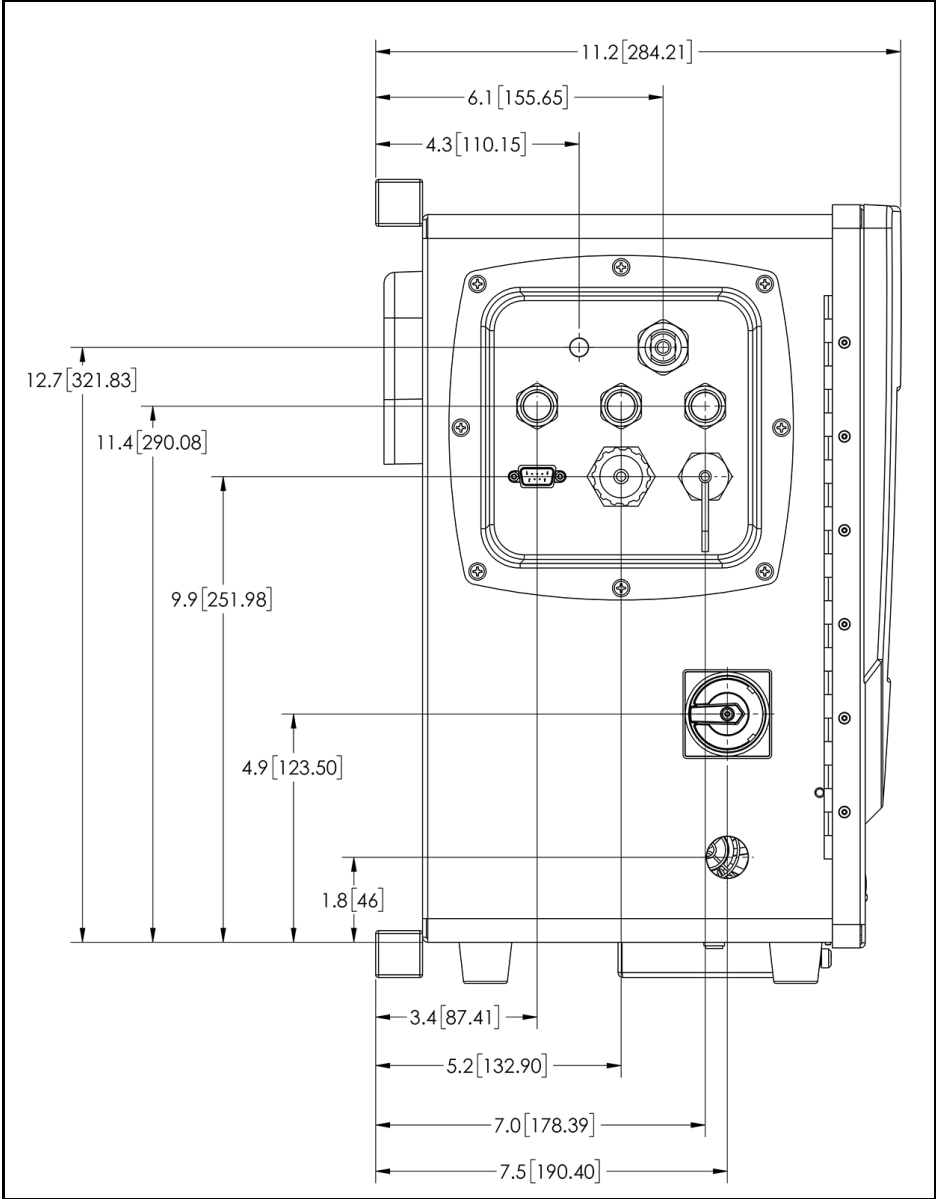

Figure 20: Left-Side Analyzer Dimensions, with Standard iOS System

Analyzer Configured with Super iOS

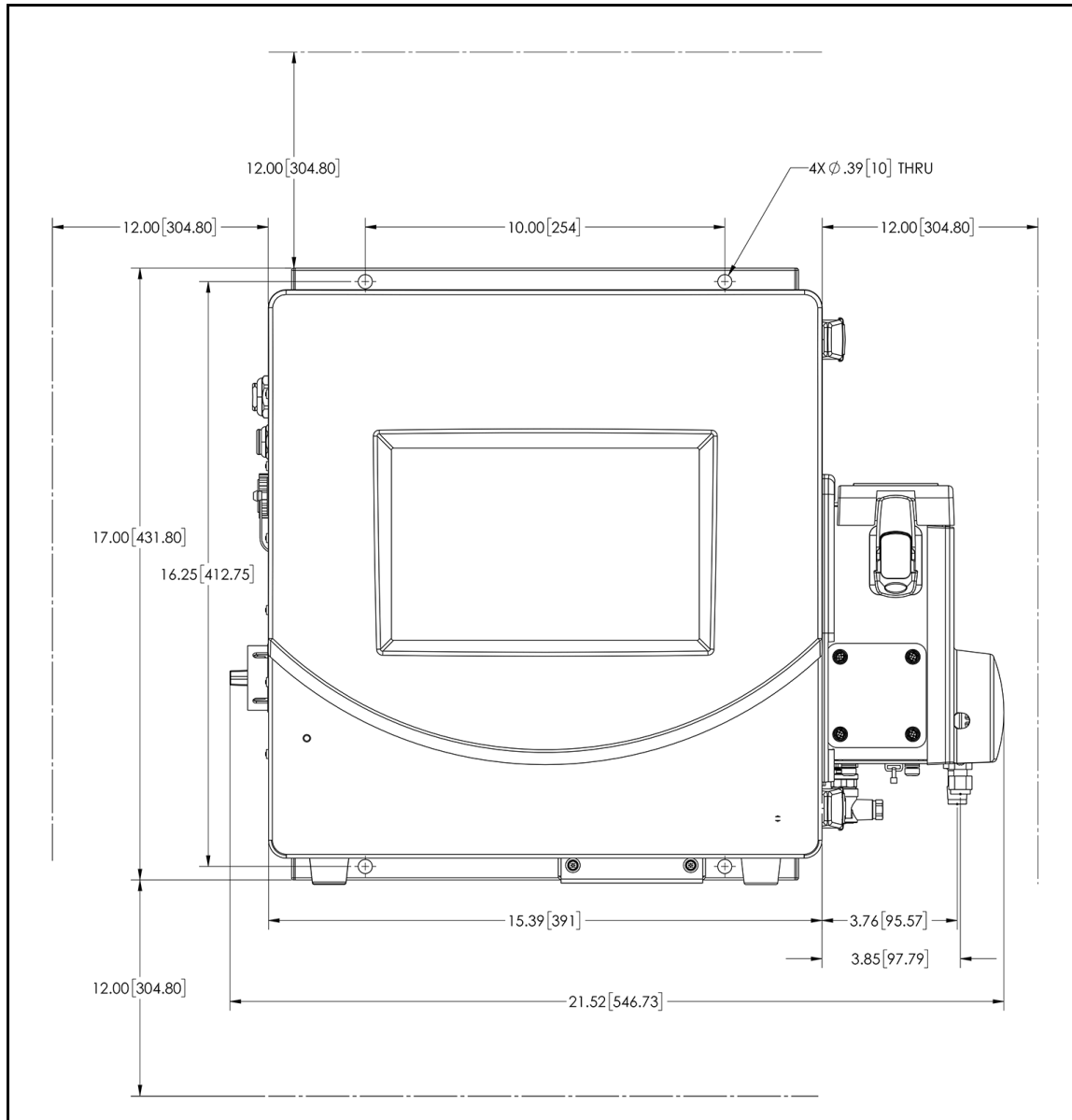

Figure 21: Analyzer Dimensions, with Super iOS System

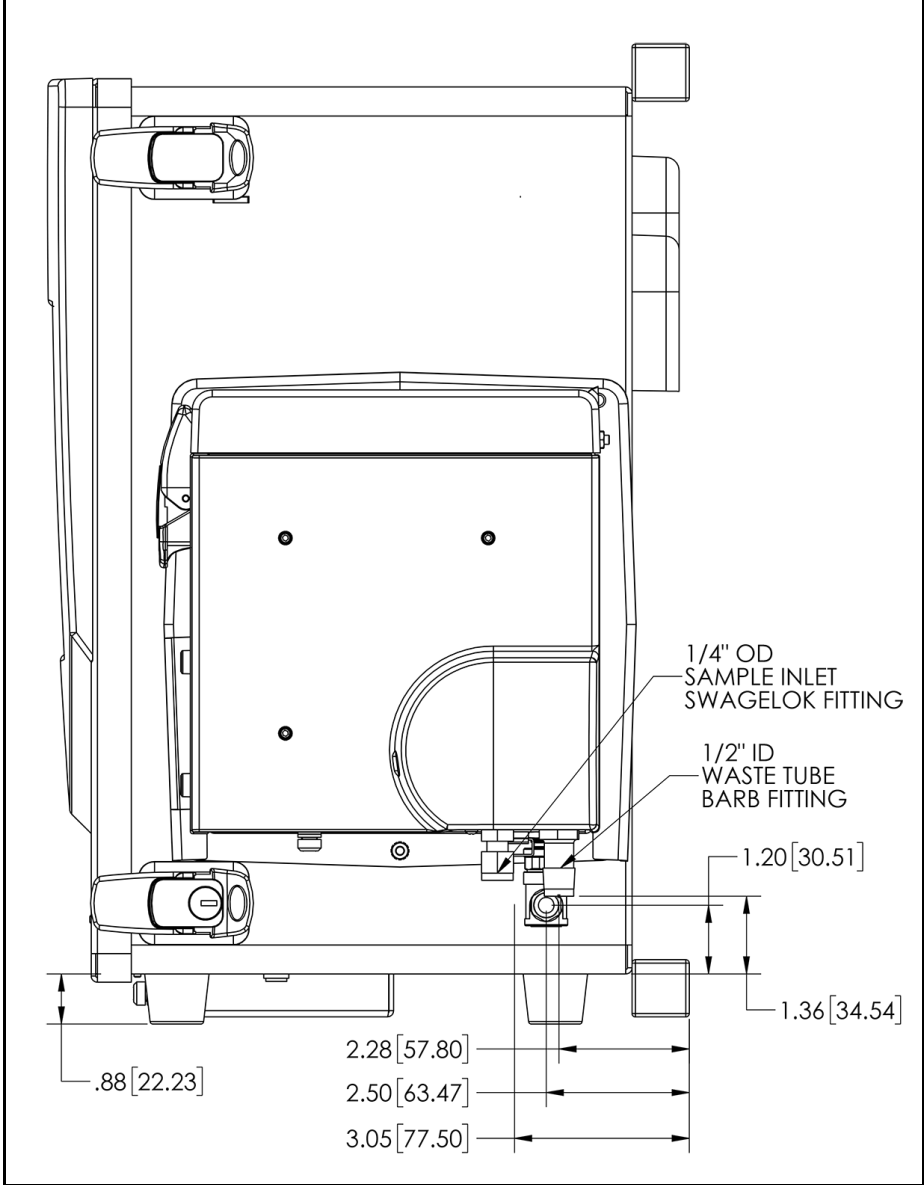

Figure 22: Right-Side Analyzer Dimensions, with Super iOS System

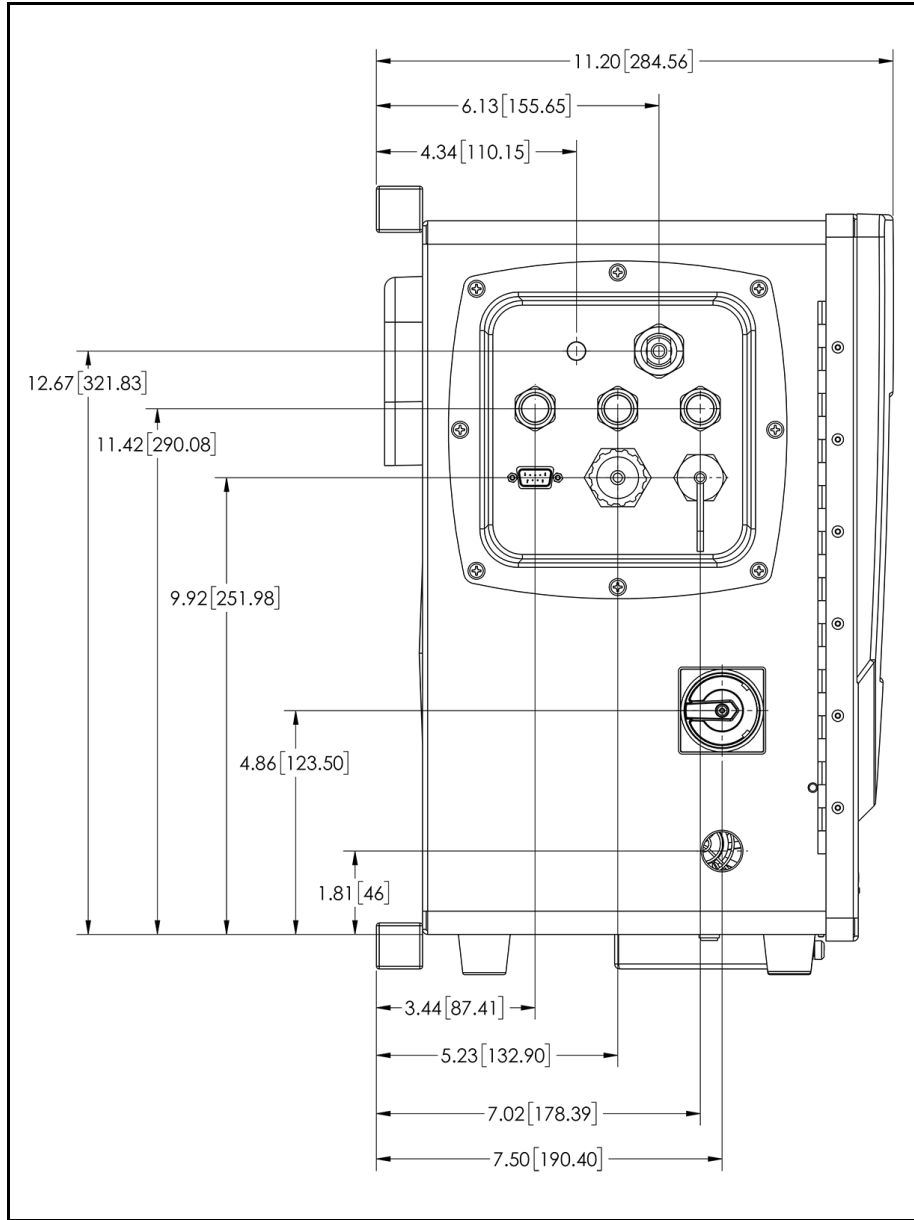

Figure 23: Left-Side Analyzer Dimensions, with Super iOS System

Analyzer Configured with Sample Inlet Block

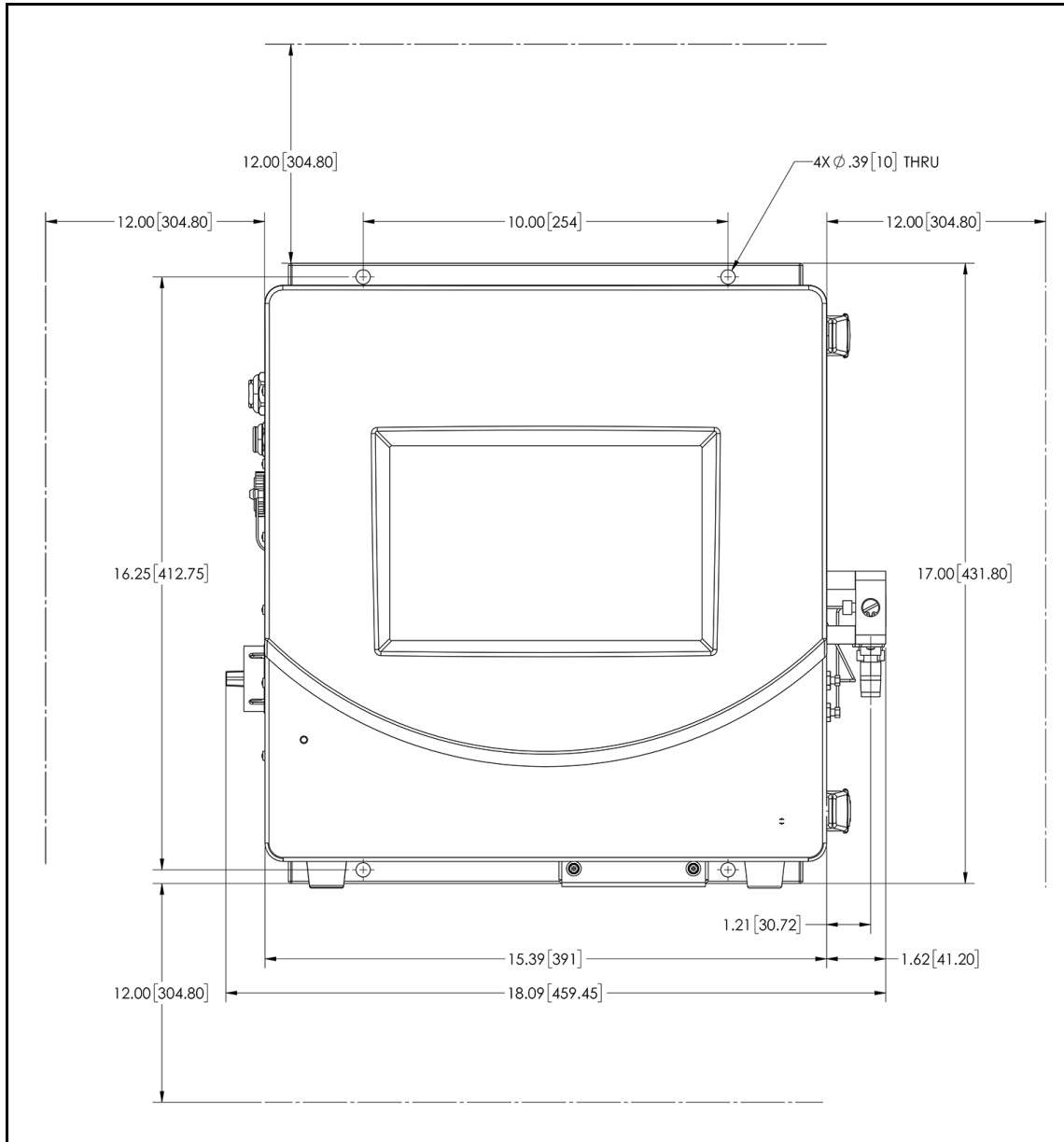

Figure 24: Analyzer Dimensions, with Sample Inlet Block

ANALYZER CONFIGURED WITH SAMPLE INLET BLOCK

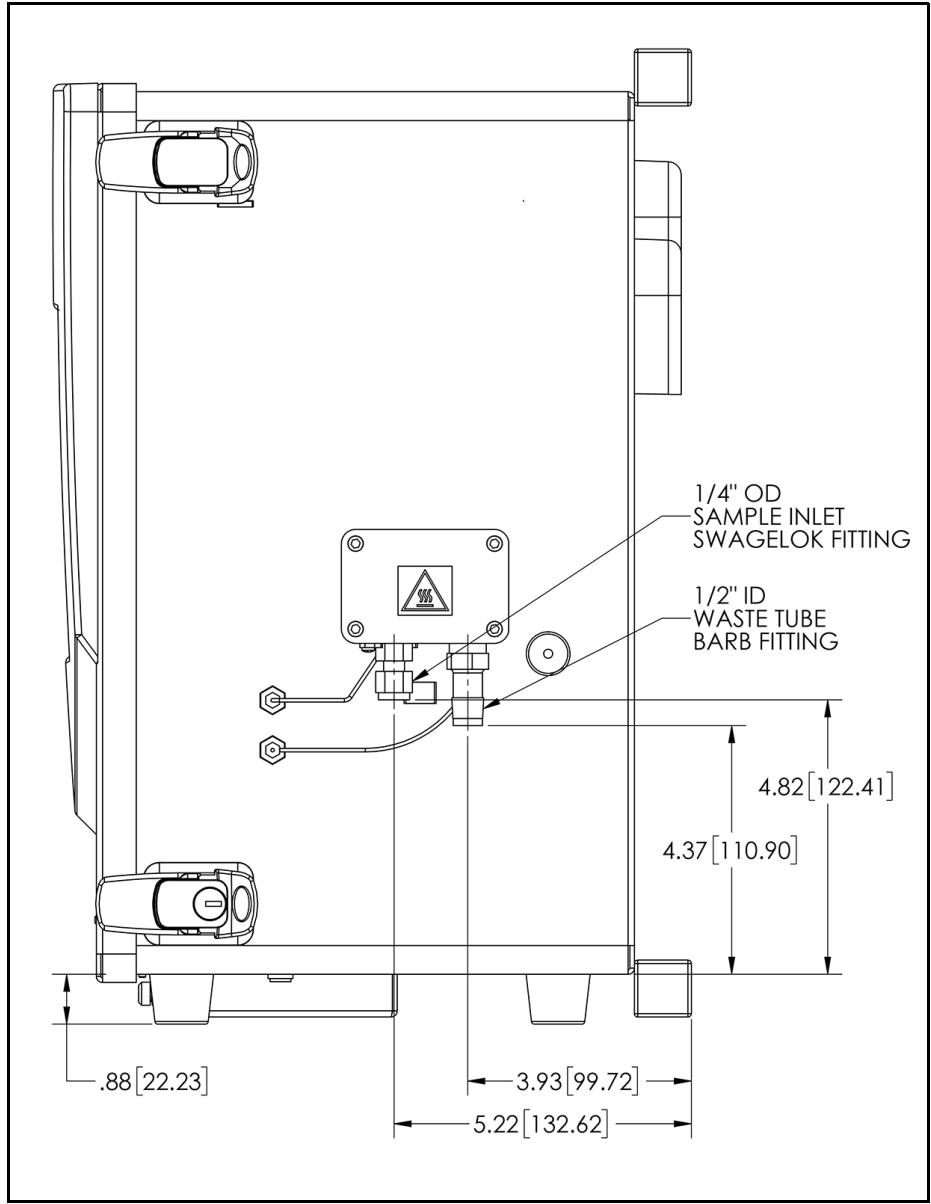

Figure 25: Right-Side Analyzer Dimensions, with Sample Inlet Block

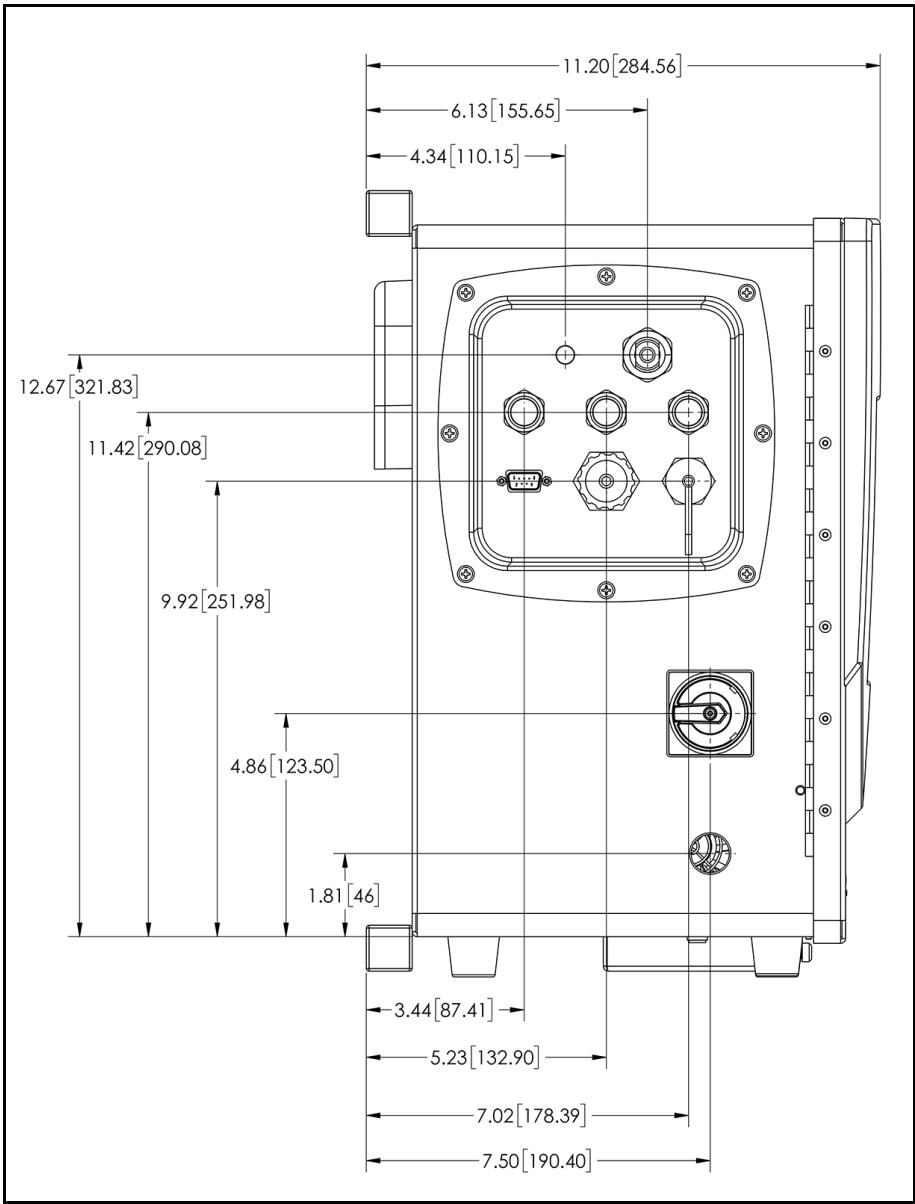

Figure 26: Left-Side Analyzer Dimensions with Sample Inlet Block

B

Appendix B: Streaming Data

.....

You can stream comma-delimited text data through the Analyzer's serial (RS-232) port or Ethernet port. This will require a third-party communications software, such as the open-source PuTTY (an SSH and Telnet client).

For each measurement, the Analyzer will output comma separated values: *mode*, *date*, *time*, *TOC*, *IC*, *TC*. If Sample Conductivity is activated, the data stream has three additional values: *rCond*, *Temperature*, *tCond*.

Example: **Online,20201130,17:35:23,1.23,2.32,3.55,2.345,25.4,3.123**

There are no units in the stream, TOC, IC, TC are output as ppb. The rCond and tCond values are output as $\mu\text{S/cm}$, and temperature is output in $^{\circ}\text{C}$.

The TOC value field may contain the string "<0.03," if measured below the detection limit.

To stream data via a serial (RS-232) port

1. Connect a serial (RS-232) cable to the Analyzer, as described in ["Installing a Serial Connection \(Optional\)" on page 88](#).
2. Make sure the Analyzer is powered on.
3. Enter the following settings in the PuTTY (or other third-party communications) software:
 - Select the *Serial* connection type. If more than one communications (COM) port is in the list, refer to the following section, as needed: ["Determining Your Communications Port Number" on page 434](#).
 - Specify the following settings:
 - Speed: 9600 bits per second (or rate that matches Analyzer setting)
 - Data Bits: 8
 - Stop Bits: 1
 - Parity: None
 - Flow Control: RTS/CTS (hardware)

4. Open a terminal window. Every time the Analyzer takes a measurement, the measurement is streamed to the computer and appears in the terminal window.

To stream data via Ethernet

1. Connect an Ethernet cable to the Analyzer, as described in [“Installing an Ethernet Connection \(Optional\)” on page 89](#).
2. Enable the Ethernet network on the Analyzer, as described in [“Configuring an Ethernet Connection” on page 100](#).
3. Make sure the Analyzer is powered on.
4. Enter the following settings in the PuTTY (or other third-party communications) software:
 - Select the *Raw* connection type.
 - Specify the following settings:
 - IP address for the Analyzer (see *System Information* on the Analyzer’s *Help*  screen)
 - Port #23
5. Open a terminal window. Every time the Analyzer takes a measurement, the measurement is streamed to the computer and appears in the terminal window.

Determining Your Communications Port Number

If the computer has more than one serial port, it is possible that more than one communication port is in use. To try to determine which communication port is being used to connect to the Analyzer, follow these steps:

1. On the computer, display the Windows **Device Manager**. For example, on Windows 10, click the **Start** button and type **Device Manager**.
2. In the *Device Manager* window, scroll down to **Ports (Com and LPT)** and show the selections. For example, on Windows 10, click the right arrow (>).
3. The communication ports in use should be listed, along with device names.



Appendix C: Warning and Error Descriptions

.....

#	Warning/Error	Name	Description
800	Warning	Sample Cell	The sample conductivity analog reading is out of range. Occurs when measuring sample conductivity, and insufficient readings are taken to be able to calculate the sample conductivity.
801	Warning	Sample Cell	The sample conductivity temperature is out of range. Occurs when measuring sample conductivity, and insufficient readings are taken to be able to calculate the sample conductivity.
802	Warning	Sample Cell	The Analyzer door is open. Occurs during the Resistance Verification protocol when the instrument door is open.
2500	Warning	Flash Memory	Flash Memory Error, invalid value was obtained. Occurs when the following constants are below 0.1: <ul style="list-style-type: none">• TC, IC, or sample cell constants• IC or TC PPT slope• MP TOC slope• MP Conductivity slope
3100	Warning	DI Loop	Unexpected DI Loop level. May occur after the Analyzer is powered on and/or each time a protocol is started.
3102	Warning	DI flow - IC	DI flow on IC/TC channel not detected. Occurs during IC/TC measurements.
4000–4299	Error	RTOS Error	Continuous RTOS error

Appendix C

#	Warning/ Error	Name	Description
5000	Error	Calibration Verification	The instrument is unable to calibrate. Please contact Technical Support or your local service provider. Occurs during calibration protocols when a calibration calculation cannot be performed due to attempting to perform an invalid math operation.
5001	Error	Calibration Verification	Calibration measurement is out of range Occurs during TOC calibration protocols, when no measurement is returned for one or more vials.
5800	Error	DI Pump	No current in the DI Pump was detected. Occurs when the DI pump is on and the Analyzer detects a current < 120 mA.
5802	Error	DI Pump	High current in the DI Pump was detected. Occurs when the Analyzer detects an unexpectedly high current in the DI pump: <ul style="list-style-type: none"> The DI pump is on and the current > 500 mA The DI pump is off and the current > 120 mA
5804	Error	IC/TC Valve	No current was detected in the IC/TC Valve. Occurs when the IC/TC valve is actuated and the Analyzer detects a current < 5 mA.
5805	Error	IC/TC Valve	The current detected in the IC/TC Valve is unexpectedly high. Occurs when the Analyzer detects: <ul style="list-style-type: none"> > 200 mA when valve is actuated > 5 mA when valve is not actuated
5807	Error	DI Loop Fan	High current in the DI Loop Fan was detected. Occurs when the fan is on and the Analyzer detects a current > 200 mA.
6800	Error	UV lamp	UV lamp failed.
6901	Error	IC sample pump	No current in the Sample Pump motor was detected. Occurs when the pump is on and the Analyzer detects a current < 60 mA
6902	Error	IC sample pump	High current in the Sample Pump motor was detected. Occurs when the Analyzer detects: <ul style="list-style-type: none"> > 1000 mA when the pump is on > 60 mA when the pump is not on
6903	Error	Sample Pump	No motion on the Sample Pump motor was detected. Occurs when the pump is running but no motion is detected with quadrature encoder.

#	Warning/ Error	Name	Description
7502	Error	Dual Conductivity	Cannot communicate with the Dual conductivity board. Occurs when the Analyzer receives no response from DC over CAN.
7503	Error	Single Conductivity	Cannot communicate with the Single conductivity board. Occurs when the Analyzer receives no response from SC over CAN.
8000	Error	Super IOS	Super IOS communication error. Occurs when the Analyzer receives no response from the Super IOS.
9000	Error	Program	Program error - no measurement mode. Occurs when a protocol is stopped and the measurement mode is not valid.
9001	Error	Program	Program error - invalid vial type. Occurs during TOC Calibration when an invalid vial type is sent from the GUI.
10002	Warning	UV Lamp	UV lamp should be replaced soon. Occurs when updating Consumables status (on startup, every hour, when updated remotely via T&C, when installing UV Lamp), if less than 15 days are left on the UV Lamp.
10003	Warning	Pump Tubing	Pump heads should be replaced soon. When updating Consumables status (on startup, every hour, when updated remotely via T&C, when installing Pump Tubing), if less than 15 days are left on Pump Tubing.
10004	Warning	Resin Cartridge	Resin bed should be replaced soon. Occurs when updating Consumables status (on startup, every hour, when updated remotely via T&C, when installing Resin Cartridge), if less than 15 days are left on Resin Cartridge.
10010	Warning	UV Lamp	Lamp has exceeded its expiration date. Occurs when updating Consumables status (on startup, every hour, when updated remotely via T&C, when installing UV Lamp), if UV Lamp is expired.
10011	Warning	Pump Tubing	Pump heads have exceeded their expiration date. Occurs when updating Consumables status (on startup, every hour, when updated remotely via T&C, when installing Pump Tubing), if Pump Tubing has expired.
10012	Warning	Resin Cartridge	Resin bed has exceeded its expiration date. Occurs when updating Consumables status (on startup, every hour, when updated remotely via T&C, when installing Resin Cartridge), if Resin Cartridge is expired.
10013	Warning	Autozero	Scheduled TOC autozero offset exceeded limit. Occurs when scheduled autozero fails

Appendix C

#	Warning/ Error	Name	Description
11000	Error	Communication	Communication error, could not open connection. Occurs when establishing connection between the GUI and the Instrument Controller, if the serial port cannot be opened for communication
11001	Error	Communication	Communication error, read timeout. Occurs when the GUI cannot read from the serial port because the Instrument Controller closed the port.
11002	Error	Communication	Communication error, write timeout. Occurs when the GUI cannot write to the serial port because the Instrument Controller closed the port.
11003	Error	Communication	Communication error, ill formed command. Occurs during Modbus communication, if invalid response is encountered.
11400	Error	Datastore	Datastore error, invalid file path. Occurs when records cannot be saved or read because data directory does not exist or the datastore file path is invalid. Also if during data export, the export file path is invalid (directory does not exist or does not allow writing).
11401	Error	Datastore	Datastore error, could not open file for read/write. Occurs when records cannot be saved because a datastore file cannot be created or opened for read/write.
11402	Error	Datastore	Datastore error, could not open file for writing. Occurs when records cannot be saved because a datastore file cannot be created or opened for writing.
11403	Error	Datastore	Datastore error, could not create file. When records cannot be saved because a datastore file cannot be created.
11404	Error	Datastore	Datastore error, record encryption failed. Occurs when a datastore record cannot be saved because encryption failed.
11405	Error	Datastore	Datastore error, could not add new record. Occurs when a new datastore record cannot be saved because the maximum count for the period was reached or the timestamp is invalid.
11406	Error	Datastore	Datastore error, could not add new record. Occurs when datastore records cannot be read (e.g., when displaying, exporting, printing).
11407	Error	Datastore	Datastore error, could not write record. Occurs when datastore record (audit trail) entry cannot be saved.



#	Warning/Error	Name	Description
11408	Error	Datastore	Datastore error, could not export record. Occurs when a datastore record cannot be exported (e.g., cannot be encrypted to PDF, export not implemented yet for data type, cannot be appended to the export file).
11409	Error	Datastore	Datastore error, could not export records. Occurs when a datastore record cannot be exported (e.g., cannot be encrypted to PDF, export not implemented yet for data type, cannot be appended to the export file).
11410	Error	Datastore	Datastore error, failure during Level 1 data parsing. Occurs when a failure occurs while loading L1 data for Level1 Diagnostics page (e.g., error while reading or invalid L1IcTc log data).
11411	Error	Datastore	Datastore error at find records in time range. Occurs if the time range for filtering records is invalid (e.g., for error history, if end date is prior to start date).
11412	Error	Datastore	Datastore error when saving system setting. Occurs if an error occurs while saving a system setting or system constant to database (e.g., cannot write to datastore, when editing or updating with value from Instrument Controller, when receiving an unexpected response from Instrument Controller instead of confirmation for saving to board, if communication with IC was interrupted).
11413	Error	Datastore	Datastore error when reading system setting. Occurs when a system setting/constant cannot be read (e.g., when displaying, exporting, printing).
11414	Error	Datastore	Datastore error when encrypting system setting. Occurs when a system setting/constant cannot be saved because an encryption error occurred.
11415	Error	Datastore	Datastore error when decrypting system setting. Occurs when a system setting/constant cannot be decrypted (e.g., when reading from datastore with invalid CRC).
11416	Error	Datastore	Datastore error when creating backup. Occurs when a manual or scheduled backup fails because the configured directory is invalid, creating the package failed, or the system is out of disk space.
11417	Error	Datastore	Datastore error when restoring backup. Occurs if restoring from the selected backup failed (e.g., if the backup file cannot be read or has an invalid format, if there is no disk space left to make a temporary safety backup of current settings before swapping with the settings from the backup).

Appendix C

#	Warning/ Error	Name	Description
11418	Error	Datastore	Datastore error when upgrading Online data. Occurs if an error occurred while converting older version Online data from datastore to the latest version.
11419	Error	Datastore	Datastore error when upgrading Grab data. Occurs if an error occurred while converting older version Grab data from datastore to the latest version.
11420	Error	Datastore	Datastore error upgrading SDBS Suit Cond data. Occurs if an error occurred while converting older version SDBS Suitability with Conductivity data from datastore to the latest version.
11421	Error	Datastore	Datastore error upgrading SDBS Suit TOC data. If an error occurred while converting older version SDBS Suitability data from datastore to the latest version.
11422	Error	Datastore	Datastore error upgrading Error History data. Occurs if an error occurred while converting older version Error History data from datastore to the latest version.
11423	Error	Datastore	Datastore error upgrading Audit Trail data. Occurs if an error occurred while converting older version Audit Trail data from datastore to the latest version.
11502	Error	Analysis	Failed initial stabilization. Occurs when a TC/IC conductivity autozero protocol completes, if the Instrument Controller sends status=1 in GZR response because the initial stabilization criteria were not met.
11503	Error	Analysis	Failed initial stabilization. When a TC/IC conductivity autozero protocol completes, if the Instrument Controller sends status=2 in GZR response for failed verification stabilization because the final stabilization criteria were not met.
11504	Error	Analysis	Protocol failed, IC channel out of range. Occurs when a TC/IC conductivity autozero protocol completes, if the Instrument Controller sends status=3 in GZR response because the new IC cell offset was not within range during the new offset verification.
11505	Error	Analysis	Protocol failed, TC channel out of range. Occurs when a TC/IC conductivity autozero protocol completes, if the Instrument Controller sends status=4 in GZR response because the new TC cell offset was not in range during the new offset verification.

#	Warning/ Error	Name	Description
11506	Error	Analysis	Protocol failed, both channels out of range. Occurs when a TC/IC conductivity autozero protocol completes, if the Instrument Controller sends status=5 in GZR response because both new cell offsets are not in range during the new offset verification.
11507	Error	Analysis	Sample conductivity out of range. Occurs when a TOC autozero or sample conductivity autozero protocol completes, if the Instrument Controller sends status=3 in GZR response because the new sample conductivity offset is not in range during the verification step.
11508	Error	Analysis	Could not read protocol configuration file. Occurs when system protocols cannot be read from the configuration file.
11513	Error	Data Parsing	Level1 data parsing error, could not log it. Occurs while running a protocol, if invalid formatted Level1 data is received.
11599	Error	GUI	Did not receive ACK response from Instrument Controller. Occurs if no confirmation was received from the Instrument Controller for a request from the GUI (e.g., for starting or stopping analysis, setting vial parameters, conductivity/resistivity setting).
11605	Error	GUI	Flash error, unable to open file for writing. When the GUI is not able to create a file or write to a file, for example if the file system is full.
11606	Error	GUI	Could not delete file on flash. Occurs when the GUI is not able to delete an existing file on the file system.
11701	Error	GUI	RAM disk file not found. Occurs when the GUI cannot execute a script or command.
11702	Error	GUI	Entry not found. Occurs when the GUI cannot execute a script or command.
11703	Error	GUI	System clock is not set. Occurs when the GUI finds out the system clock is not set .
11704	Error	Logging	Failed creating log file in log directory, exiting application. Occurs when the log directory cannot be created, so the application cannot start.
11705	Error	Logging	Failed creating log file appender, exiting application. Occurs when the logging system cannot be initialized because file appenders cannot be created.

Appendix C

#	Warning/ Error	Name	Description
11800	Error	Diagnostics	Failed setting Super iOS valve position. Occurs during Sample Flow Rate Test, if the Super iOS valve positions cannot be set.
11801	Error	Diagnostics	Failed getting Super iOS valve position. Occurs if Super iOS vial positions cannot be read from the hardware during Diagnostics.
11802	Error	Diagnostics	Could not export diagnostics. Occurs if Diagnostics Export fails because the selected export directory is not writable.

D

Appendix D: DI Water Installation Details

.....

ADDITIONAL DI WATER INSTALLATION DETAILS

Installing the resin cartridge

To install the resin cartridge

1. Continue this instruction from the previous section, [“To install the calibration resistor” on page 77.](#)
2. Locate the resin cartridge in the Analyzer’s Accessories Kit.
3. Holding the cartridge with the indicated end up, simultaneously insert one elbow-fitting end of the resin cartridge into the *Run* port and the other elbow-fitting end into the DI pump outlet.

Verify that the ends are secure before moving to the next step.

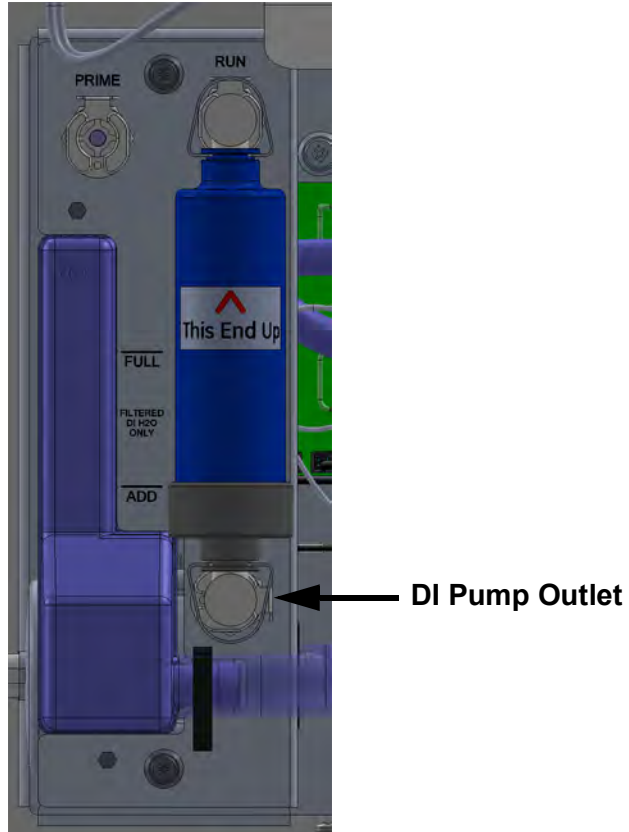

NOTE: Each port (Prime, Run, and DI Pump Outlet) has a metal latch to use when attaching or detaching a fitting. Press the latch with a finger to release a fitting and close the valve. When inserting or detaching the resin cartridge, insert or detach both end-fittings simultaneously to avoid damaging the cartridge.

4. Continue to the next section [To fill the DI water reservoir](#).

To fill the DI water reservoir

1. Continue from the previous section [“To install the resin cartridge” on page 443](#).
2. Locate the dispensing bottle in the Analyzer’s Accessories kit.
3. Have a paper towel nearby, in case of any leakage during the installation process.
4. Unscrew the lid of the dispensing bottle and fill the bottle with low-TOC DI water. Replace and tighten the lid to secure it.
5. Remove the check valve from the top of DI reservoir. Save the check valve to reinsert at the end of the fill process.



6. Insert the tip of the bottle into the hole and squeeze the bottle to fill the DI reservoir until the water line reaches the FULL line, indicated on the outside of the reservoir.
7. Re-insert the check valve into the top of the DI reservoir.
8. Manipulate the pump tubing to move any bubbles into the reservoir.

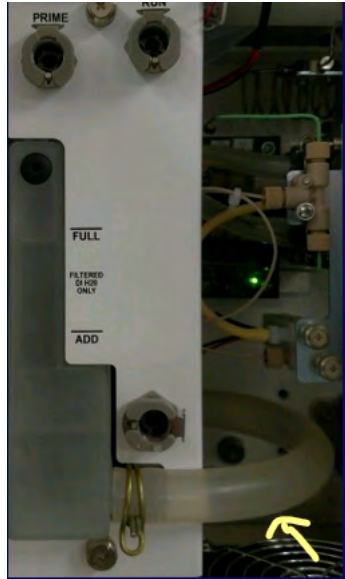

9. Continue to the next section [To prime the DI Water pump](#).

To prime the DI Water pump

This priming process helps to properly clear the DI Loop of air bubbles and saturate the resin cartridge. The priming process takes approximately 180 minutes, plus minimal setup and reset time.

1. Continue from the previous section [To fill the DI water reservoir](#).
2. Move the resin cartridge from the *Run* position to the *Prime* position. Press the top latch of the resin cartridge to release it and gently rotate the top of cartridge to the *Prime* position. Push to insert the elbow-fitting into the *Prime* port, while leaving the lower elbow-fitting end in the DI pump outlet.

Verify that the ends are secure before moving to the next step.

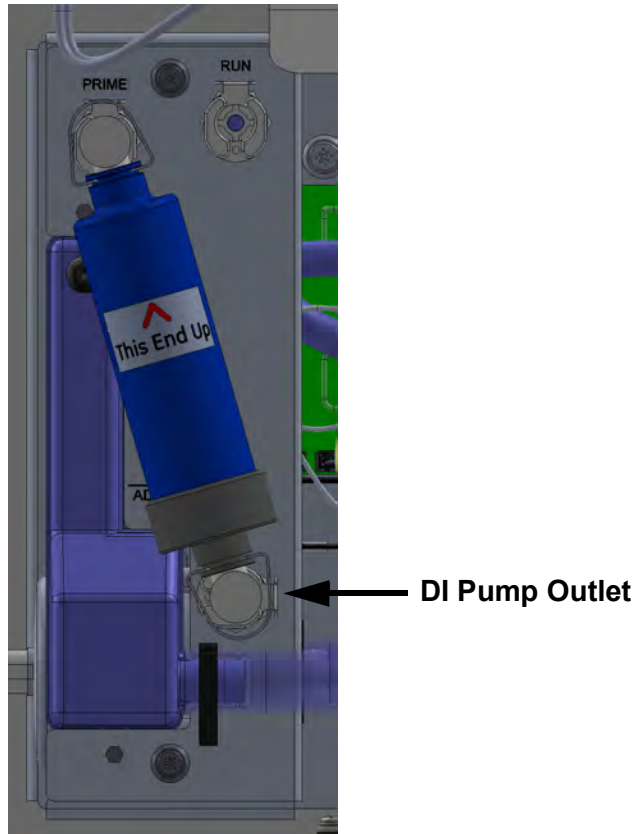

3. Turn the power switch to the **ON** position. This will turn on the DI water pump. Let the Analyzer run 180 minutes to allow the DI pump to circulate water through the DI Loop.
4. After 180 minutes, on the *Home* screen, press the **Power On/Off**  button.
5. Move the resin cartridge from the *Prime* position to the *Run* position. Press the top latch of the resin cartridge to release it and gently rotate the top of cartridge to the *Run* position. Push to insert the elbow-fitting into the *Run* port, while leaving the lower elbow-fitting end in the DI pump outlet.
Verify that the ends are secure before moving to the next step.
6. View the water level in the DI reservoir and verify that the water level reaches the **FULL** line, as indicated on the outside of the reservoir.

The water level may now be lower, as water circulates in the DI Loop and saturates the resin cartridge during the priming process. If needed, fill the DI reservoir with additional low-TOC DI water to reach the **FULL** line, indicated on the outside of the reservoir. There is no need to prime the DI pump again.
7. Close and latch the Analyzer's door.

Rinsing the Analyzer

Before placing the Analyzer in service, rinse the Analyzer using the automated *Accelerated Rinse* feature. This feature takes approximately one hour to complete.

To rinse the Analyzer

1. With a water flow established to the sample inlet system of the Analyzer, on the *Settings*  screen, select the *Hardware* tab.



2. Select the *Accelerated Rinse* in the scroll list and press the **RUN** button. The *Accelerated Rinse* dialog box appears.



3. (Optional) Select the *Start Online Analysis When Finished* option.
4. Press the **START** button. The Analyzer begins the rinse process.
5. Upon completion of the rinse (approximately one hour), a “Accelerated Rinse is complete.” message appears.
6. Press the **CLOSE** button.
7. Open the Analyzer door and inspect for any leaks (especially around the DI water reservoir).
8. If a leak is detected, verify all fittings are tight and secure. Also, confirm the water level in the DI water reservoir is full. If necessary, turn the Analyzer power switch to *Off* and add more water using the water bottle (with filling nozzle) from the Analyzer’s *Accessories* kit.
9. Close and latch the door to the Analyzer case.
10. Turn Analyzer power switch to the *On* position. The Analyzer is now ready to take valid TOC measurements.

THIS PAGE IS INTENTIONALLY LEFT BLANK.



Appendix E: Modbus with the Analyzer

.....

THE ETHERNET CONNECTION AND MODBUS

This section includes information for using Modbus, an industrial communications protocol that operates over Ethernet, on the Sievers M500 TOC Analyzer. Communications require third-party data acquisition software or a SCADA system with Modbus TCP/IP support. Modbus communications support the collection of real-time instrument data and status information. The instrument may also be started or stopped remotely via Modbus.

This section provides a basic overview of implementing Modbus on the Analyzer. This information is used in conjunction with third-party SCADA or other Modbus data acquisition software by internal Process Engineering departments. It is difficult to provide all details as the bulk of the configuration and programming is completed within the third-party device. Various vendor SCADA systems are programmed differently. As noted in the following steps, some systems require memory addresses to be formatted in a unique way, while others label Modbus functions differently.

Enabling Modbus

To enable Modbus

Before exporting data via Ethernet, ensure to configure the Ethernet output in the Analyzer's firmware. Refer to ["Configuring an Ethernet Connection" on page 165](#). The connection can be made using DHCP or a static IP address.

Refer to the ["Modbus Register Table" on page 453](#), as needed.



NOTE: Assistance may be needed from internal Process Engineering departments to set the IP address correctly for the network.

1. Confirm that an active Ethernet cable is connected to the Analyzer. The Analyzer uses the Modbus communication protocol (port 502).

Testing Modbus for the Analyzer

Use the following information when configuring Modbus with the Sievers M500 TOC Analyzer.



NOTE: This section refers to TOC values; however, other value types and information can also be configured within Modbus.

- For TOC data, the SCADA system will be reading the Modbus input registers at memory addresses 3300, 3301, and 3302. The “Function” for these memory addresses should be "04 Read Input Registers." Some software packages may refer to this function differently, such as "3x_bit" or something similar.
- The TOC data is made up of the first two input registers (two 16-bit unsigned registers) at memory address 3300 and memory address 3301. Some software packages may need the memory address formatted as 3301 or 330001, each referring to the first 16-bit register at memory location 3300.



NOTE: Units for the Analyzer are shown in part per million (PPM).

- The two 16-bit registers referenced in this section need to be combined to create one 32-bit floating point TOC value. This is necessary as Modbus only supports 16-bit registers. The SCADA software will have an option for combining these values.
- The input register at memory address 3302 can be read to display the TOC units, a value of 1=ppt, 2=ppb, 3=ppm even though the unit of measure is fixed for the M500 TOC Analyzer. This is also a 16-bit value.
- To read other values, refer to Table 5 for the correct memory addresses.
- If any issues are encountered during configuration, SUEZ suggests contacting the SCADA software supplier for technical support, as there is often a simple software-related solution. If this is unsuccessful, please contact SUEZ Technical Support or your local service provider.

THE MODBUS REGISTER TABLE

This Modbus Register table is a listing of the addresses and functions of Modbus capability. Reference Table 17, “Modbus Register Table,” on page 453. The Analyzer implements the Modbus TCP/IP standard. (For more information about Modbus, see www.modbus.org.) If there are variations in the SCADA software used, contact the supplier to understand for assistance in understanding how the software compares to the Modbus standard.

Table 17: Modbus Register Table

Register Type	Description	Function	Address	Bit
Discrete Inputs (read)	Status	2	1000	
	New Data			0
	Error			1
	Standby			2
	Alarm 1			3
	Alarm 2			4
	Alarm 3			5
	Alarm 4			6
	Activations	2	1002	
	Feature 1			0
Feature 2			1	
Feature 3			2	
Feature 4			3	
Feature 5			4	
Coils (read)	State	1	2000	
	Run			0
	Stop			1
Coils (write)	Run	5	2000	*
	Stop	5	2001	*
Input Registers (read)	Instrument Family	4	3010	*
	Instrument Model	4	3011	*
	Serial Number	4	3012	*
	Firmware Version (Major)	4	3015	*
	Firmware Version (Minor)	4	3016	*

Table 17: Modbus Register Table

Register Type	Description	Function	Address	Bit
	Firmware Version (Engineering)	4	3017	*
	Current Mode	4	3099	*
	Reading Time - Year	4	3100	*
	Reading Time - Month	4	3101	*
	Reading Time - Day	4	3102	*
	Reading Time - Hour	4	3103	*
	Reading Time - Minute	4	3104	*
	Reading Time - Second	4	3105	*
	Error Type	4	3200	*
	Error Time - Year	4	3201	*
	Error Time - Month	4	3202	*
	Error Time - Day	4	3203	*
	Error Time - Hour	4	3204	*
	Error Time - Minute	4	3205	*
	Error Time - Second	4	3206	*
	TOC Value Low Word	4	3300	*
	TOC Value High Word	4	3301	*
	TOC Units	4	3302	*
	TC Value Low Word	4	3310	*
	TC Value High Word	4	3311	*
	TC Units	4	3312	*
	IC Value Low Word	4	3320	*
	IC Value High Word	4	3321	*

Table 17: Modbus Register Table

Register Type	Description	Function	Address	Bit
	IC Units	4	3322	*
	Sample Temp. Cond. Value Low Word	4	3500	*
	Sample Temp. Cond. Value High Word	4	3501	*
	Sample Temp. Conductivity Units	4	3502	*
	Raw Sample Cond. Value Low Word	4	3510	*
	Raw Sample Cond. Value High Word	4	3511	*
	Raw Sample Conductivity Units	4	3512	*
	Sample Temp. Value Low Word	4	3700	*
	Sample Temp. Value High Word	4	3701	*
	Sample Temperature Units	4	3702	*
Holding Registers (read/write)	not used			

**All Coils (write) and Input registers are 16-bit unsigned.*

Notes:

Values are IEEE 32-bit floats split into two 16-bit registers.

TOC, TC, IC units are: 1=ppt, 2=ppb, 3=ppm

Conductivity units are: 1=nS/cm 2=uS/cm, 3=mS/cm

Temperature units are: 1=°C. 2=°F, 3=°K

Resistivity units are: 1=Ohm-cm, 2=kOhm-cm, 3=MOhm-cm

Instrument Family: M500=0x4856

Appendix E

Instrument Model: Online=20,(except M500 family which are both online
M500=0x004C, M500e=0x0065)

Installed units are: 0=Not Installed, 1=Installed

Enabled units are: 0=Disabled, 1=Enabled

Reject units are: 0=Not Rejected, 1=Rejected

Stream units are: 20=Check Standard, 10=Vial Port, 1=Stream 1, 2=Stream 2,
3=Stream 3, 4=Stream 4, 5=Stream 5

Firmware Minor is yy in xx.yy.zzz

Firmware Engineering is zzz in xx.yy.zzz

Measurement Mode: IC=10, TC=20, TOC=30, NPOC=40

Current Mode:

ON_LINE_MODE = 0

ON_LINE_TIMED_MODE = 1

ON_LINE_AVERAGED_MODE = 2

GRAB_MODE = 3

SAMPLE_CELL_SP_CALIBRATION_MODE = 4, // SP Cond Cal

SAMPLE_CELL_VERIFICATION_MODE = 5, // Sample Cond Ver

LOW_LEVEL_SP_CALIBRATION_MODE = 8

TOC_ACCURACY_PRECISION_VER_MODE = 9

SYSTEM_SUITABILITY_MODE = 10

CELL_CAL_VER_MODE = 11

RESISTANCE_VER_MODE = 12

MP_CALIBRATION_MODE = 13

LOW_LEVEL_TOC_ACC_PREC_VER_MODE = 14

TOC_LINEARITY_MODE = 15

ROBUSTNESS_MODE = 16

SPECIFICITY_MODE = 17

SDBS_SUITABILITY_MODE = 18

SDBS_SUITABILITY_WITH_COND_MODE = 19

SAMPLE_COND_LINEARITY_MODE = 20

ONLINE_TOC_LOD_LOQ_MODE = 21

IC_TC_CONDUCTIVITY_ZERO_MODE = 22

TOC_ZERO_MODE = 23

SAMPLE_CELL_ZERO_MODE = 24

UPW_SAMPLE_COND_AUTOZERO_MODE = 25

SUPERIOS_RINSE_MODE = 26

CELL_DIAGNOSTICS_MODE = 27

ACCELERATED_RINSE_MODE = 28

DRAIN_SAMPLE_SIDE_MODE = 29

STARTUP_MODE = 30

BACKFLUSH_MODE = 31

DRAIN_DI_LOOP_MODE = 32

DRAIN_SUPERIOS_MODE = 33

THIS PAGE IS INTENTIONALLY LEFT BLANK.



Appendix F: Temperature Compensation

.....

SAMPLE CONDUCTIVITY TEMPERATURE COMPENSATION

(For Analyzers configured with Sample Conductivity Only)

The Sievers M500 TOC Analyzer can be configured to include a conductivity cell to measure and report conductivity in discrete grab samples. The conductivity cell is located at the beginning of the sample flow path and can detect a raw conductivity range between 0.01 - 800 $\mu\text{S}/\text{cm}$. Using this feature requires the use of Dual Use Conductivity and TOC (DUCT) vials.



NOTE: *Conductivity is only measured with discrete grab sampling and is not available with online sampling.*

The conductivity feature option can be used to meet the “Stage 1” conductivity requirements as described by various global pharmacopeias (such as USP <645>).

When operating the Analyzer with the optional Sample Conductivity measurement, there are a number of settings and features that will help govern accuracy and provide consistency with common benchtop conductivity meters and probes. Specifically, temperature compensation, linear versus nonlinear algorithms, reference temperatures, and verification methodology will be discussed briefly below. For a more detailed discussion of these concepts, refer to our White Paper "M-Series Sample Conductivity" (300 00322 Rev B)].

The Analyzer equipped with this option measures conductivity in a manner similarly to other commercially available probes. It contains two electrodes of a fixed geometry; most electrodes are composed of a noble metal and the Sievers M500 TOC Analyzers use gold for this purpose. The Analyzer applies a known potential (voltage) across these electrodes and then measures the current (amperage) that flows between them. Using Ohm's law, the resistance, or conductance, can be calculated:

$$V = I * R$$

$$R = I / V$$

$$C = 1 / R = V / I$$

TEMPERATURE COMPENSATION

The conductivity of an aqueous solution is a function of temperature:

$$C = f(T)$$

This means that, without changing any concentrations or other parameters of the solution, the conductivity will increase as temperature increases. In addition, there are two complexities that accompany this temperature dependence of conductivity:

1. The relationship between conductivity and temperature has both linear and nonlinear relationships, depending on the concentration of ions
2. The relationship between conductivity and temperature is ion-specific; different ions will have a different mathematical relationship.

Because conductivity is a function of temperature, it can be difficult to compare a conductivity reading from one location to that in another location. For example, it is common to have both online conductivity probes on hot water for injection (WFI) loops, but also to take grab samples from the same loop for lab analysis. The online probes are measuring water that is 80 °C or higher. That same water will be near 20 °C when measured in the lab, and perhaps even colder if it had been refrigerated.

The ion content of those two samples (online and laboratory grab) might be the same, but the measured conductivity will be much different. Thus, compensating the two measurements to a reference temperature is required to evaluate the equivalence of the two measurements.

Similarly, conductivity standards used for calibration and verification are prepared to a given concentration of a specific compound at a reference temperature. For example, a standard might be listed as "100 µS/cm KCl at 25 °C." If the standard is measured at 19 °C, a response around 85-90 µS/cm is likely. Does this mean that the meter and probe used are inaccurate? Not necessarily. To recover to the nominal value on the standard's label or certificate of analysis, the standard must be maintained at the reference temperature or the results must be temperature compensated.

REFERENCE TEMPERATURE

For most regions of the world, 25 °C is the reference temperature used for compensation. It is also the temperature at which conductivity standards are certified. Some regions will use other reference temperatures, such as 20 °C. The Analyzer allows the user to select the reference temperature to use in the compensating (correction-type) algorithms (Linear and Nonlinear).

.....

REFERENCE TYPE ALGORITHM — LINEAR COMPENSATION

For samples near the reference temperature and whose expected values are larger than 10 μS/cm, a linear relationship between temperature and conductivity may be a suitable approximation. This relationship is given by the following:

$$C_t = \frac{C_\theta}{1 + \alpha_\theta(\theta - t)}$$

Where:

θ = the actual temperature of the measured sample

t = the reference temperature, typically 25 °C

C_θ = the actual measured raw conductivity at temperature θ

α_θ = the temperature compensation coefficient

C_t = the theoretical conductivity compensated to the reference temperature t

The temperature compensation coefficient, or linear constant, can often be found in the literature or reputable sources^{1,2} published on the Internet. Some common constants are listed in the following table:

TABLE 18: COMMON LINEAR CONSTANTS

Species	Linear Constant
NaOH 5%	1.72
NaOH 30%	4.5
HCl 5%	1.58
HCl 10%	1.56
HCl 30%	1.52
KCl 5%	2.01
KCl 10%	1.88
KCl 20%	1.68
UPW	5.5
Drinking Water	2
H ₂ SO ₄ 5%	0.96
H ₂ SO ₄ 50%	1.93
H ₂ SO ₄ 98%	2.84

1. Mäntynen, M. 2001, Working Report 2001-15. *Temperature correction coefficients of electrical conductivity and of density measurements for saline groundwater*, Posiva Oy.
2. J.J.Barron and C. Ashton, *The Effect of Temperature on Conductivity Measurement* (Part of a comprehensive series of papers that the authors have written covering all of the practical requirements for accurate conductivity measurement available at www.reagecon.com).

TABLE 18: COMMON LINEAR CONSTANTS

Species	Linear Constant
NaCl 10%	2.14
Dilute ammonia	1.88
Sugar Syrup	5.64

REFERENCE TYPE ALGORITHM — NONLINEAR COMPENSATION

While there are certain conditions where a linear approximation can be valid, the true relationship between conductivity and temperature is nonlinear. In ultra-pure waters, including dilute salt solutions, the nonlinearity can become significant. If the standards and samples being tested and standards are expected to be less than 10 $\mu\text{S}/\text{cm}$ or significantly different from the reference temperature, it is important to select an appropriate nonlinear compensation algorithm. In general, this relationship is governed by the following equation:

$$C_t = \frac{C_\theta}{1 + \alpha_\theta(\theta - t)}$$

Where

λ_a and λ_b are limiting ionic conductance of the individual ions
 m is the moles of salt in solution
 C_{H_2O} is the conductivity of pure water
 T is the actual temperature of the measurement

The Analyzer has three nonlinear compensation algorithms from which to choose:

- KCl
- NaCl
- HCl

If nonlinear compensation is a suitable model for your samples or standard, refer to [“Working with Pharmacopoeia Monographs” on page 143](#) for a step-by-step procedure.

OTHER COMPENSATION CONSIDERATIONS

If you are using a dilute standard of an unlisted compound or are unsure which nonlinear model best supports your application, please contact Technical Support or your local service provider.

.....

VERIFICATION METHODOLOGY AND EXPECTATIONS

Calibrating at a higher point than the nominal measurement can be advantageous for ensuring stability and accuracy. However, this is only true if the linearity of the instrument can be demonstrated.

For the purposes of verification, lower level standards are often sought. Verification standards can tolerate more variability because that variability is specific to the measurement of that single measurement. That lower level standard's variability does not propagate through successive measurements the way a calibration standard's error will.

A controlled study ([Figure 27: Linearity of Sievers M500 TOC Analyzer Conductivity Measurement](#)) performed by Analytical Instruments demonstrates the linearity of the Sievers M500 TOC Analyzer's conductivity measurement. Using commercially available 100 $\mu\text{S}/\text{cm}$ sodium chloride (NaCl) standards with carefully controlled serial dilutions, the following data were collected:

This shows a high degree of linearity down to 1.00 $\mu\text{S}/\text{cm}$ based on a calibration point of 1.409 mS/cm.

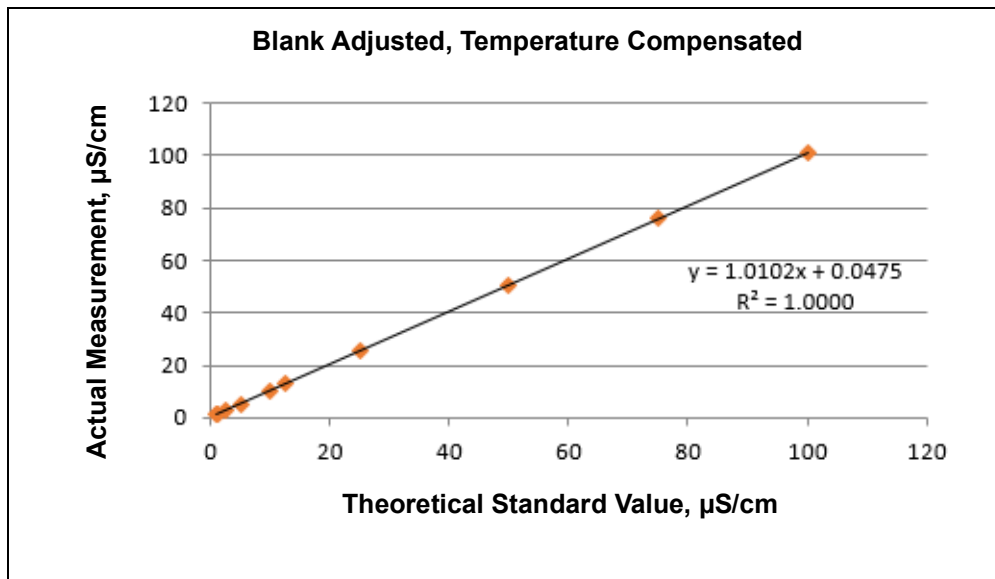

Figure 27: Linearity of Sievers M500 TOC Analyzer Conductivity Measurement

Conducting validations can be performed for two purposes:

1. To comply with regulations, such as USP <645> and equivalent

To ensure that the instrument is performing to internal expectations

The first purpose mandates that the relevant sections of the compendia be followed and documented. One of these criteria found is an accuracy specification of 2% to the nominal value of the verification standard. Thus, the recovery of 1.0 $\mu\text{S}/\text{cm}$ and 5.0 $\mu\text{S}/\text{cm}$ verification standards would have to be

Appendix F

in the 0.98 - 1.02 $\mu\text{S}/\text{cm}$ and 4.9 - 5.1 $\mu\text{S}/\text{cm}$ ranges, respectively. In both cases, nanoSiemens of variability will cause failure. And, unfortunately, it is common for these standards themselves to have uncertainties in the 2 - 20% range.

Thus, it is exceedingly difficult to pass compendial verification at the point of interest, which is near 1.0 $\mu\text{S}/\text{cm}$. Thus, we use a 25 $\mu\text{S}/\text{cm}$ verification to achieve compendial verification and rely on linearity studies to demonstrate the instrument is fit for use.

If low-level conductivity standards (for example, 1, 5, 10 $\mu\text{S}/\text{cm}$) are preferred for use in internal verifications, we recommend taking the manufacturers' certificate of analysis uncertainty into consideration when establishing pass/fail criteria, including the instrument accuracy and common sources of contamination (such as atmospheric CO_2).

For additional information, regarding performing a *Sample Conductivity Verification*, please contact Technical Support or your local service provider.

Index

A

- Access Levels
 - creating and revising 200
- Additional System Components 59
- Administrator
 - Access Level 200
- Advanced Analyzer Settings 166
- Analyzer
 - dimensions 423
 - dimensions with Sample Inlet Block 430
 - dimensions with Standard iOS System 424
 - dimensions with Super iOS System 427
 - screens 120
 - unpacking and inspecting 62
- Analyzer Schematic 57
- Archive
 - manual 179
- Audit Trail
 - working with 210
- Autozero
 - sample conductivity cell 380
 - TOC 380

B

- Backup
 - automatic 177
 - manual 175
- Basic Analyzer Operation 113
- Binary input
 - installing 70
 - setting 110, 163

C

- Calibration
 - preparing for 222
 - required supplies 217
- Calibration and System Protocols 213
- Calibration resistor 77
- Conductivity cell 459
- Conduit
 - power 72
- Constants, see System Constants

Consumables

- replacing 407
- resin cartridge 415
- sample pump tubing and pump heads 413
- UV lamp 410

D

- Data
 - streaming 433
- Data History
 - setting up 140, 145
- Data outputs
 - system components 59
- Database
 - automatic backup 177
 - manual archive 179
 - manual backup 175
 - manual restore 183
- DataGuard 89, 91, 189, 191
 - adding User IDs 196
 - audit trail 210
 - changing passwords 207
 - enabling 194
 - forgotten passwords 209
 - logging in 194
 - logging out 212
 - login settings 205
 - managing user accounts 195
- DI Water pump
 - prime 446
- DI water reservoir 444
 - filling 409
 - filling instructions (installation) 77
- Dimensions
 - Analyzer 423
 - Analyzer with Sample Inlet Block 430
 - Analyzer with Standard iOS System 424
 - Analyzer with Super iOS System 427

E

- Errors and Warnings, reviewing 370
- Ethernet
 - configuring 100, 165

- connecting to Modbus 451
- installing cable 89
- installing connection 89
- Setting up Modbus Connection 173

- Ethernet cable
 - installing 89
- Ethernet port
 - streaming data 433

- Exporting
 - from Analyzer screens 124
 - System Constants 148
 - System Settings 148

F

- Firmware
 - updating 156

G

- Grab sample
 - running 132

H

- Home screen 126

I

- Important Information
 - confidentiality 14
 - Standard Limited Warranty 15
 - trademarks and patents 14
- Inactivity timeout 90, 192, 206
- Install power 72
- Installation 61
 - completing the identification records 64
 - remote start (binary input) 70
 - selecting a location 64
 - serial (RS-232) connection 88
 - unpacking and inspecting the Analyzer 62
 - USB device 87
- Instrument Startup Wizard 77
- Introduction 53
- iOS System
 - proper use 117

L

- Location, naming 138
- Logging In 194

- Logging Out 212
- Login attempts
 - alarm 90, 192

M

- Main Screen 131
- Maintenance
 - sample pump tubing and pump heads 413
 - UV lamp 410
- Marker 407
- Microprocessor controller and electronics 59
- Modbus
 - configuring 452
 - enabling 451
 - Enabling and Configuring 173
 - Ethernet connection 451
 - testing 452
- Modbus Register table 452

N

- Negative, High, or Erratic Measurements 379

O

- Online analysis
 - running 131
- Operator
 - Access Level 200

P

- Packing list 62
- Pass/Fail reporting 143
- Password
 - changing 207
 - deactivated 209
 - expiration 206
 - for Password Protection 91, 192
 - forgotten 209
 - incorrect attempts before User ID is suspended 206
 - length 206
 - required characters 206
 - reuse 206
- Password of the Day 209
- Password Protection 89, 189, 191
 - defining password 91, 192
- Pharmacopoeia 144
- Power

- installing 72
- Power conduit 72
- Power off 115
- Prime the DI Water pump 446
- Printer
 - enabling 101, 170
- Printing
 - from Analyzer screens 123

R

- Resin cartridge 443, 446, 447
 - replacing (maintenance) 415
- Restore
 - database 183
- Roles
 - assigning to Access Level 200
 - list 202
- Roles and role abilities 202
- RS-232 port
 - streaming data 433

S

- Sample Conductivity Cell
 - autozero 380
- Sample Flow Path 57
- Sample Inlet
 - installation 75
- Sample Inlet Block 119
- Sample Pump Heads
 - replacing 413
- Screens
 - Analyzer 120
- Serial connection
 - installing 88
- Serial port
 - streaming data 433
- Solutions for Basic Problems 376
- Standard iOS System
 - proper use 117
- Startup
 - wizard 77
- Streaming data 433
- Super iOS System
 - cartridge data 118
 - proper use 118
- Supervisor
 - Access Level 200
- System Constants

- exporting 148
- restoring 184
- saving 148
- System Description 55
- System information
 - displaying 190
- System Overview 56
- System Settings
 - exporting 148
 - restoring 184
 - saving 148
- System Specifications 55

T

- Terminal Blocks
 - connecting to 64
- Theory of Operation 53
- Timeout
 - user inactivity 90, 192, 206
- TOC Autozero
 - programming 214
- TOC Measurements
 - starting and stopping analysis 131
- Toolbar
 - using 120
- Troubleshooting 367
 - preparing the Analyzer for shipping 399
 - visual inspection 367

U

- Upgrade
 - firmware 156
- USB memory device
 - installing 87
- User
 - inactivity timeout 90
- User ID 206
 - inactivity timeout 206
 - suspension 206
- User IDs
 - adding 196
 - changing passwords 207
 - forgotten passwords 209
- Users
 - managing accounts 195
- UV Lamp
 - replacing 410

V

Vial Sets

cartridges 118

W

Warnings 19

Warnings and Error Messages 373

Warnings and Errors

descriptions 435

Wizard

Instrument Startup 77

NOTES
