

Thermo Scientific AquaSensors Measurement System



Thermo Scientific™ AquaSensors™ measurement system for convenient plug & play.

Markets/Applications:

- Municipal and industrial wastewater
 - Aeration tanks
 - Aerobic digesters
 - Plant effluent monitoring (NPDES permit holders)
 - Anaerobic digesters
- Aquaculture
- Brewing
- Fermentation
- Bio-processing
- Many applications also exist in chemical process, food and dairy, pulp and paper, and other process industries

Thermo Scientific AquaSensors RDO® Pro-X DO Sensor

- The latest generation in rugged luminescent dissolved oxygen technology for wastewater monitoring
- 0 to 20 ppm measurement range
- No membranes – field replacement caps every two years
- High precision and accuracy with fast and stable response
- No conditioning necessary prior to use – fast start up
- Reduced maintenance – long lasting calibration
- Resists photo-bleaching and abrasive process media
- No “poisoning” by sulfides
- No cross sensitivity to carbon dioxide, ammonia, pH, sulfide, sulfate, chloride, or hydrogen sulfide
- Plug and play design with digital network interface
- Immersion and ball-float mounting configurations
- Versatile mounting configurations
- Three-year sensor warranty



Thermo Scientific AquaSensors RDO Pro-X Dissolved Oxygen Sensor

Connect this advanced optical dissolved oxygen sensor directly to a PLC for seamless integration with industrial control systems. Use any computer to display data, calibrate and customize the measurement without an intermediate analyzer electronics box. Optional AV38 local display/controller is also available for more conventional installations offering single or dual sensor inputs. An AquaPro controller is also available for up to four sensor inputs.

This versatile system is ideal for monitoring all dissolved oxygen levels throughout a wastewater treatment plant.

Engineering Specifications

1. The dissolved oxygen (DO) sensor employs advanced online luminescent sensor technology.
2. The sensor material is Delrin® and Polystyrene. All parts of the DO sensor are corrosion resistant and submersible.
3. The measurement range is 0.00 to 20.00 mg/L dissolved oxygen or 0 to 200 % saturation.
4. The operation of the analyzer is not affected by “poisoning” from sulfides and have no cross sensitivity to carbon dioxide, ammonia, pH, sulfide, sulfate, chloride, or hydrogen sulfide.
5. The sensor withstands “thermal shocking” and photobleaching effects from ambient light.
6. The sensor exhibits minimal hydration effects; no conditioning is necessary prior to use.
7. The sensor provides electrolyte-free operation without the requirements of additional sample conditioning.
8. The sensor is furnished with a selection of immersion or ball float mounting assembly options.
9. The sensor cap is warranted for two full years against defects in material and workmanship.
10. The sensor probe is warranted for three full years against defects in material and workmanship.
11. The analyzer is the AquaSensors RDO Pro-X for dissolved oxygen measurement available through Thermo Scientific AquaSensors.

Thermo Scientific AquaSensors RDO Pro-X Sensor Schematic

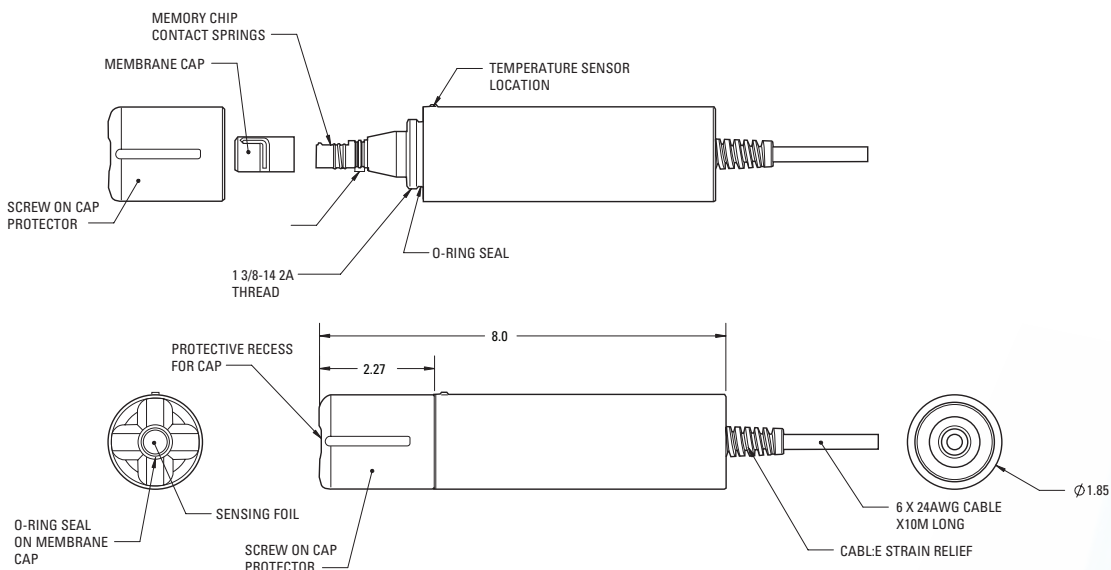

The RDO Pro-X provides conversion of sensor signals and interactive communications for measurement, calibration, configuration and diagnostics. Mounting adapters, junction boxes and recharge kits are available.



Ball Float Assembly

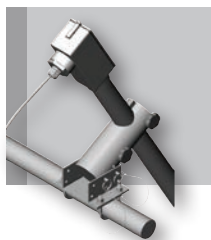

Hand Rail Mounting Assembly



1 Inch Immersion Mounting with Junction Box (7 Foot Extension is Standard)

How The RDO Pro-X Works

This second generation rugged dissolved oxygen (DO) follows the ‘dynamic luminescence quenching’ principle. The AquaSensors RDO Pro-X sensor advances lifetime-based optical fluorescence technology to provide an extremely stable, accurate, low-maintenance DO sensor. Sensor optics include a lens, blue LED and filter, red LED and filter, and a photodiode or photodiode (see Figure 1).

When the blue LED emits light, it causes the lumiphore molecules embedded in the gas-permeable sensing foil to emit red photons.

The RDO Pro-X sensor measures the ‘phase’ (or delay) of the returned signal compared to the excitation signal, which makes it based on the ‘lifetime’ rather than the ‘intensity’ of the luminescence. The presence of oxygen in the foil quenches the luminescence and causes a phase shift in returned signal detected by the photodiode (see Figure 2). The phase difference between the blue excitation light and the return red light is measured, and the result is used to quantify the dissolved oxygen present.

Eliminating Problems Associated with Electrochemical DO Sensors

Dissolved oxygen (DO) is one of the most important parameters monitored when evaluating water quality, aquatic biology, and related processes. Until development of optical DO technology, the ability to accurately monitor DO levels over long periods of time was limited. Electrochemical sensors (Clark, Galvanic) require sample stirring or process flow and are functionally limited by the durability of their membrane and electrode, while galvanic diffusion types offer characteristically slow response.

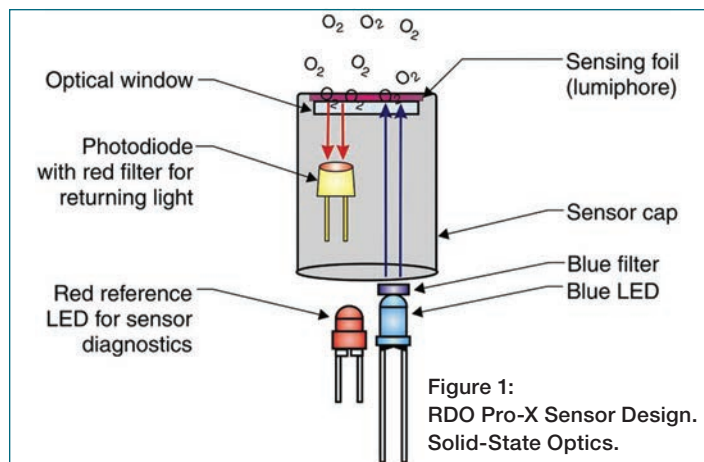
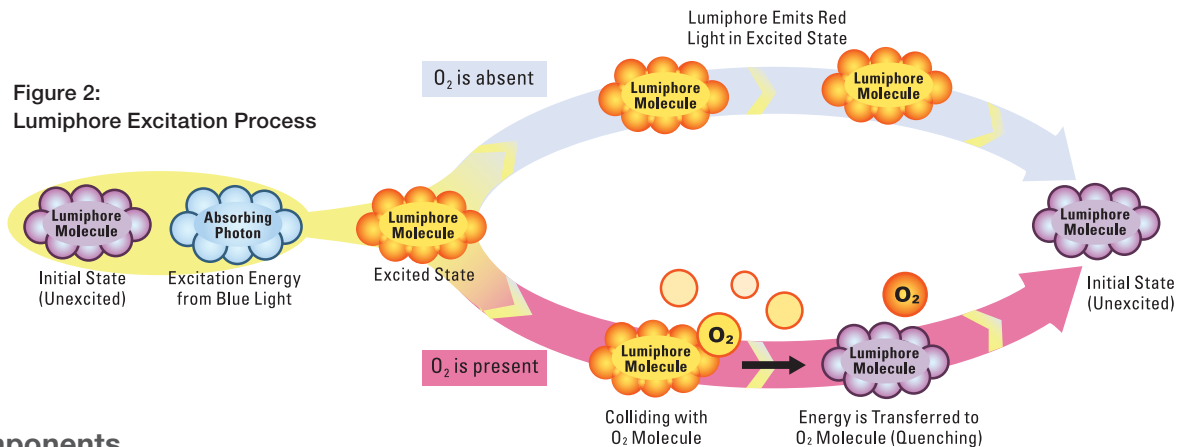

Figure 1:
RDO Pro-X Sensor Design.
Solid-State Optics.

Figure 2:
Lumiphore Excitation Process



Key Components

AquaPro Local Display/Controller

The Thermo Scientific AV38 is a universal display interface for AquaSensors DataStick sensor systems as well as RDO Pro-X DO sensors. The enclosure has ¼ DIN dimensions for easy mounting and is rated NEMA 4X for outdoor use. It uses a liquid crystal display (LCD) with a high contrast backlight for best readability and is powered with 24 volts DC or optionally with line power (100 VAC to 240 VAC). It will accept 1 or 2 RDO Pro-X sensors for local display and control. Digital host communication options are also available in this device.



Wash Head Assembly

Thermo Scientific Model MH1222-RD. In applications where the sensor head is quickly fouled, a wash head assembly can be employed. The head attaches to the body of the RDO Pro-X sensor where the wash nozzle is focused on the sensing area. Upon securing the wash head to the sensor a hose is connected from the wash head to plant air or water. An optional packaged air compressor can also be specified. Actuation of a solenoid control valve is controlled by an AV38 wash relay or PLC that is programmed for a wash interval and duration.



Thermo Scientific AquaSensors RDO Pro-X Optical Dissolved Oxygen Sensor

Global support — with experience that comes from supporting our customers for over 35 years throughout the world, our water quality specialists and customer support teams offer a quick, thorough and professional response to any problem encountered.

Focus on user benefits — we work closely with you to define your needs, and ensure you are using the monitor in a way that improves your bottom line. For more information, contact your local water quality specialists or visit: www.thermofisher.com/water.

Specifications	
Measurement System Performance	<p>Range: 0 to 20 ppm, 0 to 200 % saturation</p> <p>Resolution: Below 10 ppm; 0.01 ppm, 0.1 % sat Above 10 ppm; 0.1 ppm, 0.1 % sat</p> <p>Accuracy: ±0.1 ppm up to 8 ppm, ±0.2 ppm from 8 to 20 ppm</p> <p>Step Response Time: 90 % in 30 seconds (at 25 °C) 95 % in 37 seconds</p>
Operational Environment	<p>Temperature Range: 0 °C to 50 °C (32 °F to 122 °F)</p> <p>Maximum Pressure: 300 psig @ 50 °C</p> <p>Maximum Flow Rate: No flow required</p>
Power Requirements†	Voltage Range: 8 to 36 VDC
IP Rating	Environmental: IP-67 with cap off, IP-68 with cap installed
Construction	<p>Sensor Head Material: Delrin & Polystyrene</p> <p>Weight: 0.93 lbs (without cable)</p> <p>Dimensions: 8 inches long (203.2 mm), 1.85 inch diameter (47 mm)</p> <p>Mounting Requirements: 1.25 inch NPT (internal thread on back of sensor for adapting to immersion hardware and floats)</p>
Units Of Measure	<p>Measurement Units: Dynamic Luminescence Quenching</p> <p>Temperature Units: °C, °F</p>

Calibration‡	<p>Air: Automatically adjusts for set pressure</p> <p>Sample: 1 or 2 point</p> <p>Zero: 1 point</p> <p>Temperature: 1 point</p>
Measure Modes	<p>Dissolved Oxygen: ppm, %</p> <p>Temperature: Automatic from -5 °C to 50 °C</p>
Output/Communications	<p>Oxygen: Partial pressure, ppm and % sat</p> <p>Temperature: °C, °F</p> <p>Digital Protocol: Modbus® RTU (RS485)</p>
Configuration Options	<p>Sensor Filter: 0 to 100 seconds</p> <p>Temperature Filter: 0 to 100 seconds</p>
Approvals	CE, FCC, RoHS
Warranty	<p>Sensor: 3 years</p> <p>Sensor Cap: 2 years</p>

† Note: Class II DC power supply required

‡ Use either air saturated water, or water saturated air as preferred methods

Ordering Information	
Part No.	Description
RD6A43	RDO Pro-X sensor with Modbus RTU (RS485) interface and 30' (10 m) cable
RDC1	Replacement RDO Pro-X sensing cap
RDN1	Replacement RDO Pro-X sensor nose cone
RDG1	Replacement RDO Pro-X sensor O-ring(s)
RDO Pro-X Sensor Accessories	
Local Display & Control	
AquaPro	Multi input process analyzer; ½ DIN with current outputs, relays and digital communications. See AquaPro brochure for configuration.
AV38	Local display/controller/interface; ¼ DIN with current outputs, relays and digital communications
Wash Adapters	
MH1222-RD	Air purge assembly, CPVC
MH5225-RDX	RDO high pressure assembly with air compressor, CPVC
Mounting Hardware	
MH3083-RD	1 inch immersion mounting assembly, 7-foot with junction box, PVC
MH1242-RD	1 inch immersion mounting with swivel rail-mount, 7-foot with junction box, PVC
MH1252-RD	1 inch immersion mounting with swivel rail-mount, 7-foot with junction box and ball float

Consult factory for additional configurations and accessories.

Water and Lab Products



Australia: (613) 9757-4300 In Australia: (1300) 735-295 **China:** (86) 21-6865-4588
Germany: (49) 6184-90-6321 **India:** (91) 22-6716-2261/2247 **Japan:** (81) 045-453-9175
North America: 1-978-232-6000 Toll Free: 1-800-225-1480 **Singapore:** (65) 6778-6876

Find out more at thermofisher.com/water

ThermoFisher
SCIENTIFIC