

Metal seated valves



Introduction

Metal seated ball valve

Habonim's tough line of metal seated valves excels in the harshest industrial environments, where valve failures can damage plant efficiency, reduce profitability and endanger safety. Habonim's meticulously engineered metal seated valve can withstand the harshest applications and process conditions, including extreme high temperature, high pressure and abrasive medium. Careful metallurgical selection of all valve parts, the development of special surface, including and hard coatings, and thorough analyses of mechanical strength and thermal expansion ensure that the Habonim MTM line is the best choice for industry's toughest applications.

The lower temperature range from -60°C (-76°F) to 400°C (752°F) undergoes Habonim's unique surface treatment, LTPN (Low Temperature Plasma carbo-Nitriding). LTPN is a cost effective hardening system for austenitic stainless steel, which provides a minimum thickness of 40 microns and more than triple (>68HRC) the natural hardness of the base material.

For the higher temperature range from 400°C (752°F) and up to 538°C (1000°F) Habonim offers various HVOF spray solutions based on chromium and tungsten carbides.

For the even higher temperature range from 538°C (1000°F) and up to 650°C (1200°F) Habonim uses ASME B16.34 listed forged bar material for the construction of the valve pressure-containing elements.

For the severe abrasive conditions of the pulp and paper industry, Habonim offers also a minimum of 1.5 mm thick, hard stellite coating. Each coating is specifically engineered to the customer's application in order to provide outstanding resistance to abrasion and corrosion for a lifetime of effective operation in harsh applications.

Each ball and seat sub-assembly is accurately machined, ground and then mate-lapped for a perfect match. The complete valve assembly demonstrates high repeatability in terms of sealing (Rate B - factory tested), low torque and smooth operation at various temperatures and pressures.

Habonim uses ASME B16.34 listed cast material for the valve body and ends.

Standards of compliance

Factory certification	ISO 9001-2008	Quality management system
Valve design & tests	ANSI B16.34, API 608, API 6D / ISO 14313, ISO 17292 ANSI B1.20.1 ISO 7-1, JIS B0203 DIN 3852 ANSI B16.11, EN 12760 ANSI B16.25, EN12627-4 ANSI B16.5, EN 1092 Pt 1&2 ANSI B16.10, EN 558 NACE MR-0175, ISO 15156-1/2/3 EN 12266-1, API 598, ANSI FCI 70-2	Valve design NPT - National Pipe Taper thread BSPT - British Standard Pipe Taper thread BSPP Socket weld end connection Buttweld end connection (Schedule 5, 10, 40, 80) Flange dimensions Face-to-Face dimensions Materials for use in H ₂ S-containing environments in oil and gas production Testing of metallic valves - Pressure tests, test procedures and acceptance criteria.
Certifications	API 607, ISO 10497 PED 97/23/EC, PED 2014/68/EU Module H ATEX 94/9/EC IEC 61508-2 SIL 2/3	Testing of valves - Fire type-testing requirements Pressure equipment directive equipment and protective systems intended for use in potentially explosive atmospheres (optional for actuated unit only) Safety integrity level - Functional safety of electrical/ electronic/programmable electronic safety-related systems (optional for actuated unit only)
Documentation	EN 10204 2.2 / 3.1 / 3.2	Metallic materials - types of inspection documents

Valves design

Basic design

Temperature range	-60 °C to +400 °C (-76 °F to +752 °F)
Surface treatment	LTPN
Materials	Stainless steel A351 CF8M/CF3M, A479 316/316L, Carbon steel A216 WCB, A105, A350 LF2

T design

Temperature range	-60 °C to +538 °C (-76 °F to +1000 °F)
Coating	HVOF Cr ₃ C ₂ (Chromium Carbide), HVOF WC-Co (Tungsten Carbide) and Stellite
Materials	Stainless steel A351 CF8M/CF3M, A479 316/316L, carbon steel A216 WCB, A105, A350 LF2

T design

Temperature range	-60 °C to +650 °C (-76 °F to +1200 °F)
Coating	HVOF Cr ₃ C ₂ (Chromium Carbide)
Materials	Stainless steel A479 321/321H, A182 F22

Operation	Lever or gear operated, pneumatic or electric actuated
------------------	--

Series in range

Z47 / Z47T series

Standard and full port

Size range	¼" - 2" (DN8 - DN50)
Pressure range	ANSI Class 600 Vacuum 10 ⁻⁶ Tor to 103 bar (1490 psi)
Size range	2½" - 8" (DN65 - DN200)
Pressure range	ANSI Class 600 Vacuum 10 ⁻⁶ Tor to 70 bar (1015 psi)
End connections	Threaded, welded, flanged

Z73 / Z73T series

Full port

Size range	½" - 8" (DN15 - DN200)
Pressure range	ANSI Class 150 Vacuum 10 ⁻⁶ Tor to 20 bar (290 psi)
End connections	Flanged

Z74 / Z74T series

Full port

Size range	½" - 8" (DN15 - DN200)
Pressure range	ANSI Class 300 Vacuum 10 ⁻⁶ Tor to 50 bar (725 psi)
End connections	Flanged

Z78 / Z78T series

Full port

Size range	½" - 2" (DN15 - DN50)
Pressure range	DIN PN40 Vacuum 10 ⁻⁶ Tor to 40 bar (580 psi)
End connections	Flanged

Z77 / Z77T series

Full port

Size range	3" - 8" (DN80 - DN200)
Pressure range	DIN PN16 Vacuum 10 ⁻⁶ Tor to 16 bar (230 psi)
End connections	Flanged

Z28 / Z28T series

Standard and full port

Size range	¼" - 6" (DN8 - DN150)
Pressure range	ANSI Class 2500 (wall thickness) Vacuum 10 ⁻⁶ Tor to 414 bar (6000 psi)

Floating Ball Valves

Metal seated valves	General	Up to 400 °C / 752 °F	Up to 538 °C / 1000 °F	Up to 650 °C / 1200 °F	Ordering code system
----------------------------	---------	--------------------------	---------------------------	---------------------------	-------------------------

Design features up to 400 °C / 752 °F

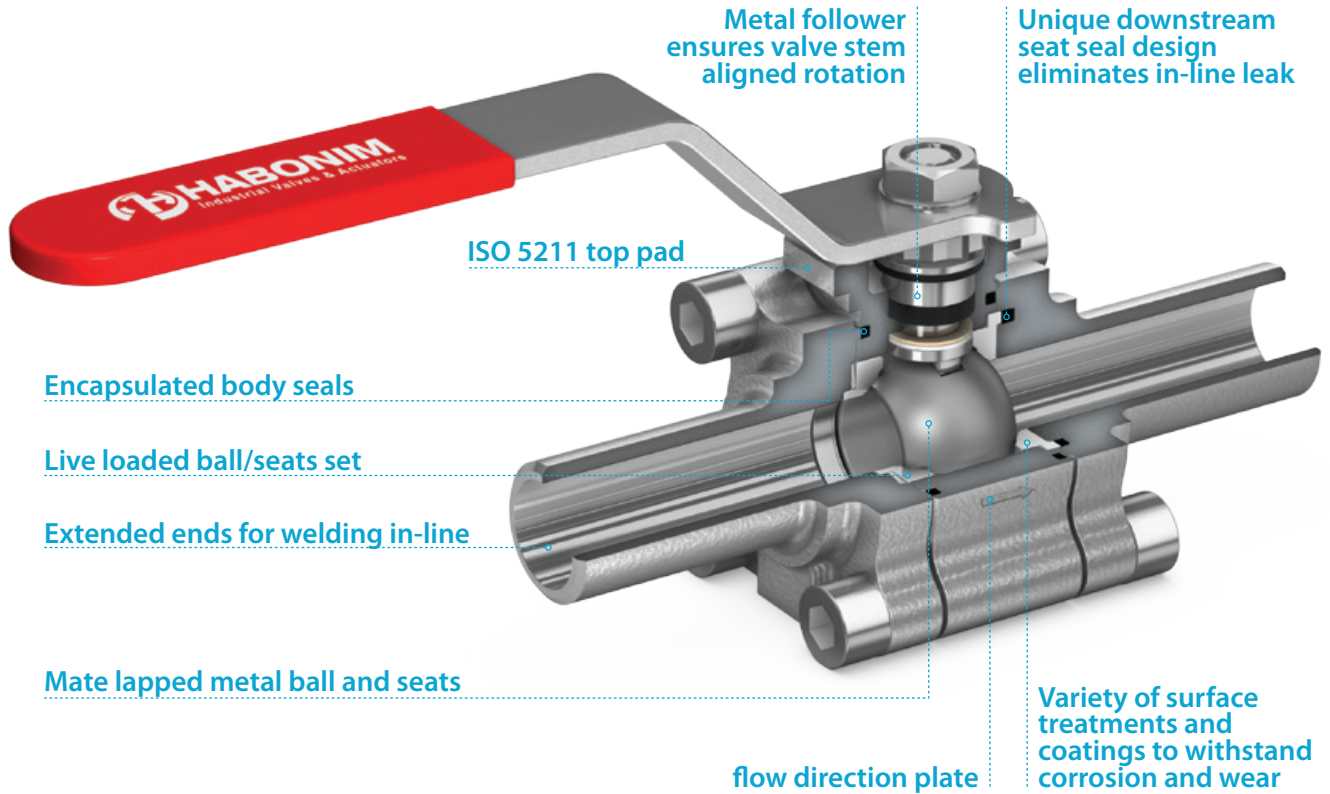

Body

- Standard and full port design
- Unidirectional
- High flow capacity and minimum turbulence
- Fire safe design to API 607 and ISO 10497

Ball and metal seats set

- Leak rate to EN12266-1 Rate B (factory tested) is achieved by accurate grinding and lapping processes
- Various surface treatments and coatings available for superb corrosion and abrasion resistance
- Constant preload of ball/seats set obtained by Inconel 718 Belleville spring
- Low operating torque

Stem

- Blowout-proof design
- Solid one-piece
- Tight stem-to-ball engagement
- High torque durability
- Live loaded stem seal

Minimum thermal expansion

- One size up and shorter body bolts
- Additional spring washers

Tongue & groove labyrinth design

- Zero leakage into the atmosphere
- Full compression of encapsulated body seal
- Accurate alignment of all parts

T Series unique design features up to 538 °C / 1000 °F

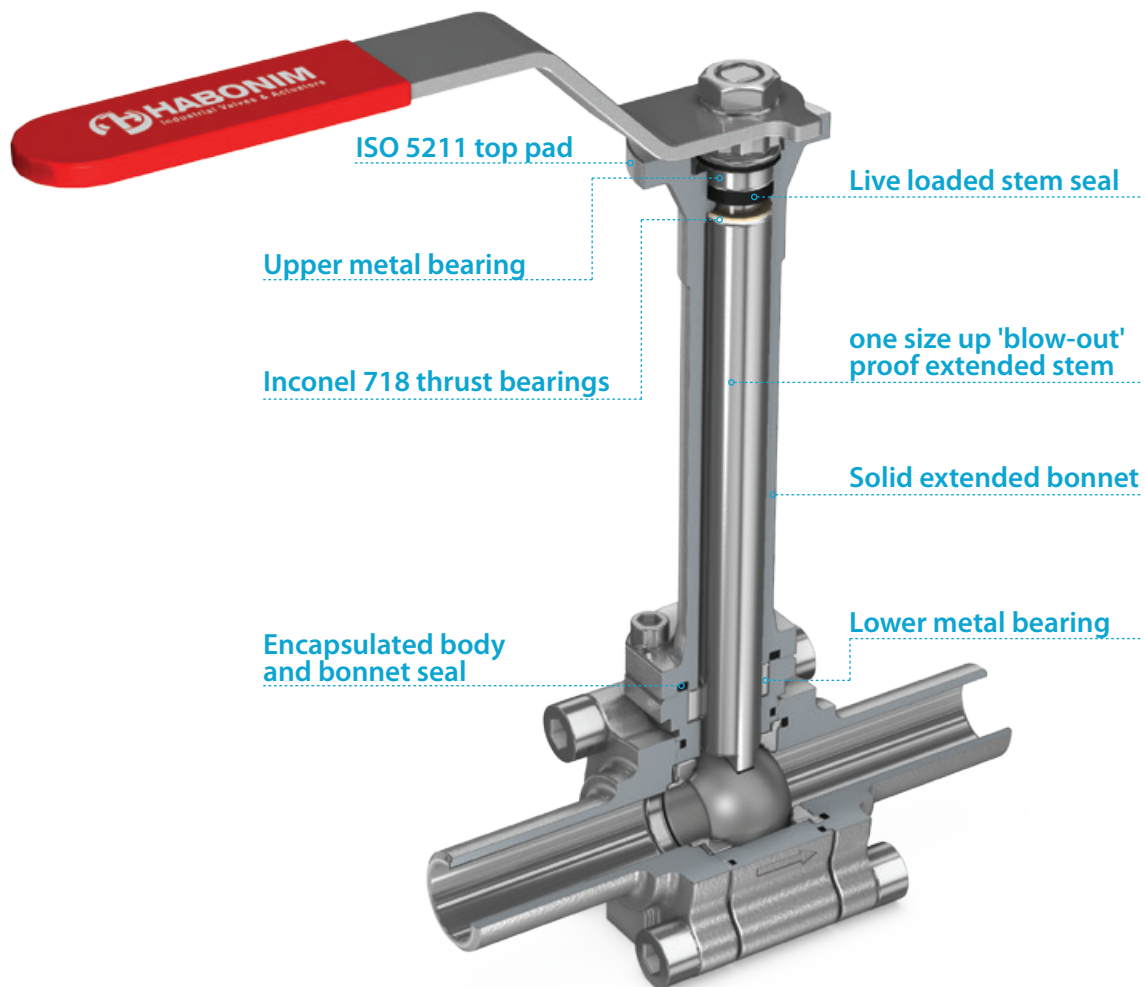

Body

- Solid cast body and ends
- Standard and full port design
- Accurate alignment of all parts
- High flow capacity and minimum turbulence
- Fire safe design to API 607 and ISO 10497

Ball and metal seats set

- Various coatings available for superb corrosion and abrasion resistance
- Constant preload of ball/seats set obtained by Inconel 718 Belleville spring

Body seals

- Encapsulated body and bonnet seal guarantees zero leakage

Bonnet

- Solid extended bonnet allows safe operation at extremely high temperature
- Remote automatic operator will work under moderate environment conditions
- Low maintenance and operation requirements

Stem

- Oversized non-rising extended stem perfectly aligned durable even under heavy load.
- Broad ball-stem connection allows torque transfer with no surface compressive deformation
- Two metallic bearings ensures valve stem aligned rotation
- Inconel 718 thrust bearings eliminate galling of stem and valve body

Stem seal

- Live loaded expanded graphite stem seal guarantees low emission

Floating Ball Valves

Metal seated valves

General

Up to
400 °C / 752 °F

Up to
538 °C / 1000 °F

Up to
650 °C / 1200 °F

Ordering
code system

T Series unique design features up to 650 °C / 1200 °F

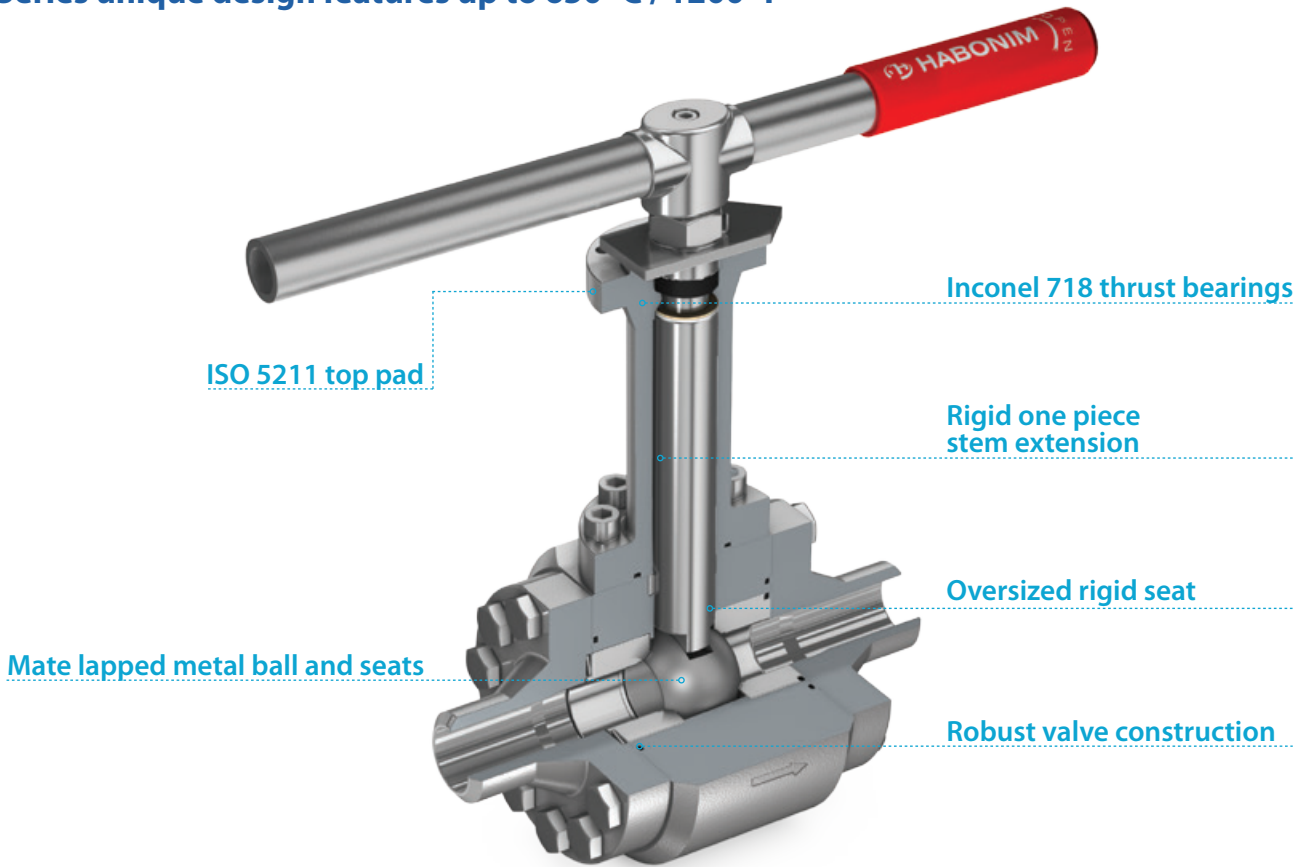

Body

- Full compliant with ASME B16.34
- Robust body and bonnet construction from special alloys
- Double the number of shorter bolts reduces thermal expansion and maintain valve shell integrity even at elevated temperatures and pressures
- Bolts maintain mechanical properties at temperatures as high as 800 °C / 1472 °F
- ISO 5211 top platform for easy mounting of actuator and accessories

Stem

- Perfectly aligned extended stem
- Oversized blow out-proof extended stem capable of delivering high torque load
- Broad ball-stem connection allows torque transfer with no surface compression deformation
- Two metallic bearings ensure valve-stem aligned rotation
- Inconel 718 thrust bearings eliminate galling of stem and valve body

Ball and metal seats set

- Rigid metallic seats maintain geometric accuracy over wide ranges of pressure and temperature load
- Leak rate to EN12266-1 Rate B (factory tested) is achieved by accurate grinding and lapping processes
- HVOF coatings available for superb corrosion and abrasion resistance
- Constant preload of ball/seats set obtained by Inconel 718 Belleville spring

Seats design options

Standard seat design

Description	Spring loaded uni-directional
Material	SS 316 + LTCPN, SS 410 + Cr ₃ C ₂
Seal	Expanded graphite
Spring	Inconel 718
Temperature	-60° C + 650° C (-76° F + 1200° F)
Shutoff class	BS-EN 12266-1 Rate C, FCI 70-2 Class V (Rate B, Class VI upon request)
Service	Steam, Thermal oil, clean gases, Filtered fluids

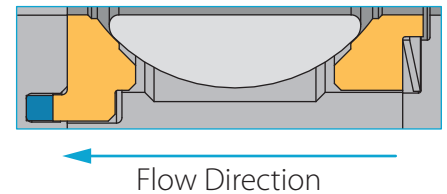

Type B

Description	bi-directional, Spring loaded, solid proof
Material	SS 316 + LTCPN, SS 410 + Cr ₃ C ₂
Seal	Expanded graphite
Spring	Inconel 718
Temperature	-60°C + 650°C (-76° F + 1200° F)
Shutoff class	BS-EN 12266-1 Rate C, FCI 70-2 Class V
Service	Steam, Thermal oil, clean gases, Filtered fluids

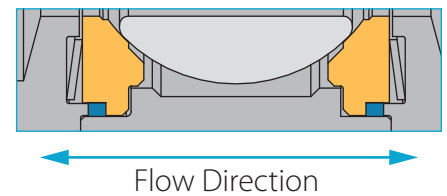

Type C

Description	bi-directional, solid proof
Material	SS 316 + LTCPN, SS 410 + Wc-Co, SS 316 + Stellite
Seal	PTFE, Expanded graphite
Temperature	-60°C + 235°C (-76° F + 455° F)
Shutoff class	BS-EN 12266-1 Rate D, FCI 70-2 Class IV
Service	Pulp & paper, slurries, catalyst

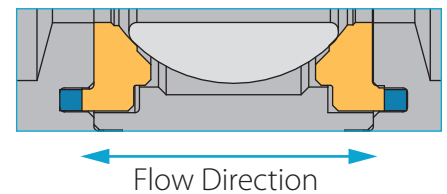

Type D

Description	bi-directional shutoff, Spring loaded, solid proof
Material	SS 316 + LTCPN, SS 410 + Wc-Co, SS 316 + Stellite
Seal	Expanded graphite
Spring	Inconel 718
Temperature	-60°C + 538°C (-76° F + 1000° F)
Shutoff class	BS-EN 12266-1 Rate C, FCI 70-2 Class V
Service	Pulp & paper, slurries, catalyst

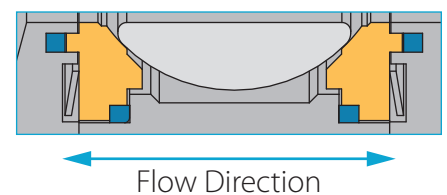

LTPN technology

Low Temperature Plasma carboNitriding (LTPN) technology

Austenitic stainless steels (304, 316) have excellent chemical resistance to corrosion and are used extensively in a variety of environments and industries including oil & gas, marine, medical, chemical and petrochemical. The use of these steels is limited, however, due to their low wear resistance, low hardness and sensitivity to galling. Conventional surface treatments, such as nitriding, are very effective in providing metallic surfaces with high wear resistance. However, high temperature processes will cause chrome carbide and nitride formation, thereby lowering the free chromium percentage of the part exposed to the high temperature and decreasing its corrosion resistance.

Limiting the temperature of the heat treatments to less than 450 °C / 842 °F forms a supersaturated layer with excellent wear resistance, while at the same time preserving the corrosion resistant properties of the stainless steel. Special, parametric processes of plasma nitriding for austenitic stainless steel have been successfully developed. These processes yield a gradual hardness profile, to give an optimal stress distribution within the treated depth. A micro-hardness of over 1000HV (equivalent to 72 HRC) is achieved on the surface of the parts, imparting the steel with a high degree of scratch and wear resistance.

The ideal solution for severe applications up to 400 °C / 752 °F

Habonim's unique LTPN surface treatment improves mechanical wear properties of austenitic stainless steels without affecting their corrosion resistance. LTPN provides austenitic stainless steel, ball and seats with the additional hardness necessary to operate without galling at elevated temperatures. For example, at 400 °C / 752 °F the LTPN layer retains its hardness for 15,000 hours of continuous operation, which typically translates into an in-service life-expectancy of 20 months. The rate at which the LTPN layer decomposes decreases exponentially with temperature reduction. Figure 1 shows the life-expectancy for the LTPN layer at different application temperature levels.

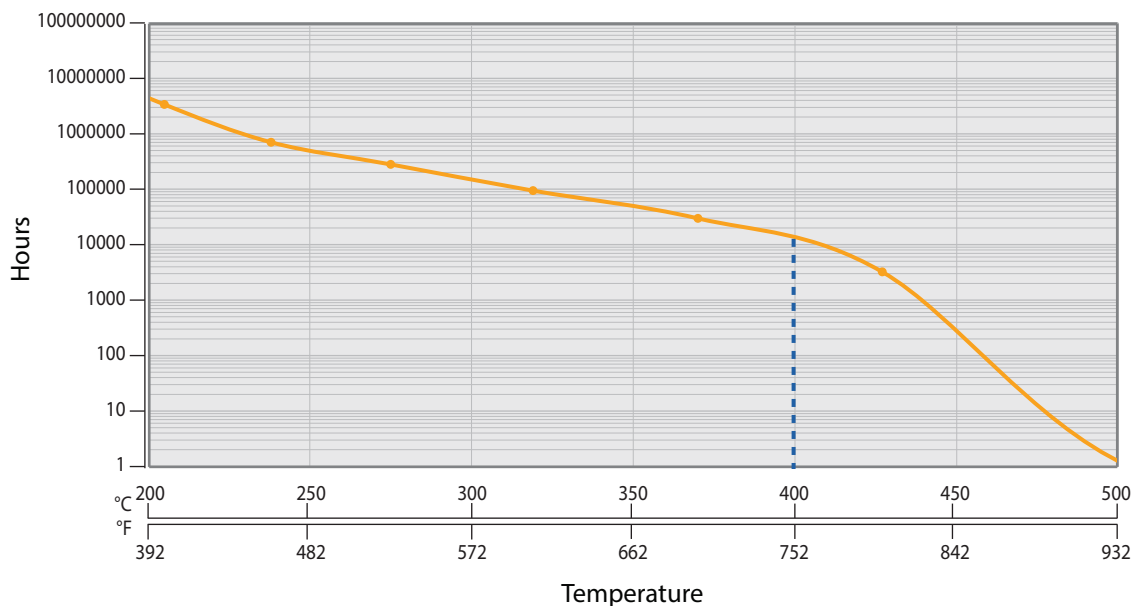

Figure 1
Life-expectancy for the LTPN layer at different application temperature levels

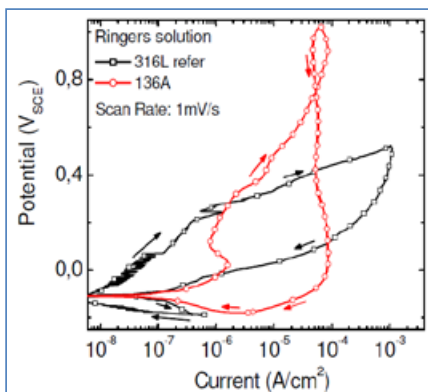

Figure 2
Anodic polarization test, showing better resistance of LTPN surface treatment to pitting corrosion than 316L stainless steel

Wear resistance

Different tests have been developed and applied to quantify the wear property. In most cases, special samples are prepared and then tested for weight loss against an abrasive media. The wear behavior is influenced by the surface properties, the wearing media and the wear imposing mode. The wear geometry is that of an intersection of a steel sphere with a flat or spherical treated surface, under a steady applied force. At the beginning of the test a very high pressure (force/contact surface) is applied between the rotating steel sphere and the sample. Gradually, as wear continues, a spherical dimple forms. Measuring the dimple diameter is associated with the wear resistance of a given layer. High wear resistance correlates to small dimple diameter.

Figure 5 shows a comparison of wear rates between different hardening technologies and untreated 316L material. It clearly demonstrates the superior wear resistance provided by LTPN.

Figure 3
Wear machine in process

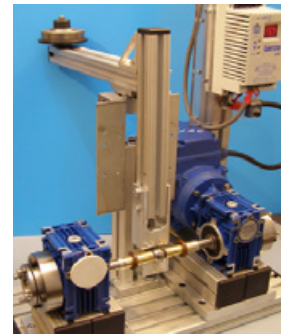

Figure 4
Typical wear dimple after 15 min

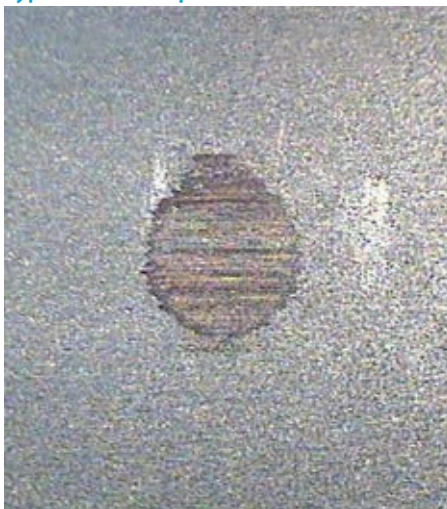
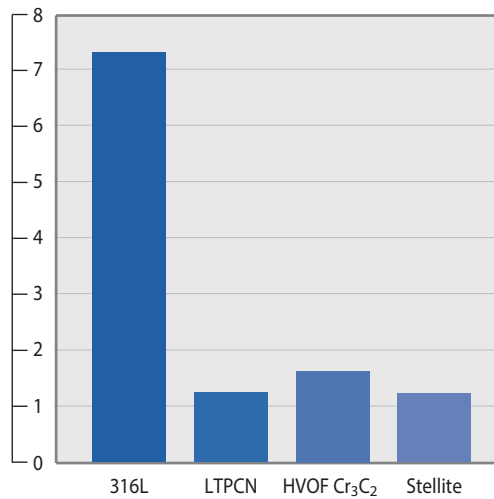

Figure 5
Comparison of wear rates between untreated 316L, LTPN treated AISI 316L, Cr₃C₂ spray coat (HVOF), and Stellite overlay



Quality assurance

The quality of each LTPN batch is approved for hardness profile, thickness, and uniformity of the hard layer. An effective testing process of the hardened layer has been established, which includes: cutting a sample, bakelite embedding, grinding and polishing of the metallographic specimens, and finally a micro-hardness test. Upon request Habonim QA will generate a copy of the metallurgical test report as part of the complete QA documentation for the product.

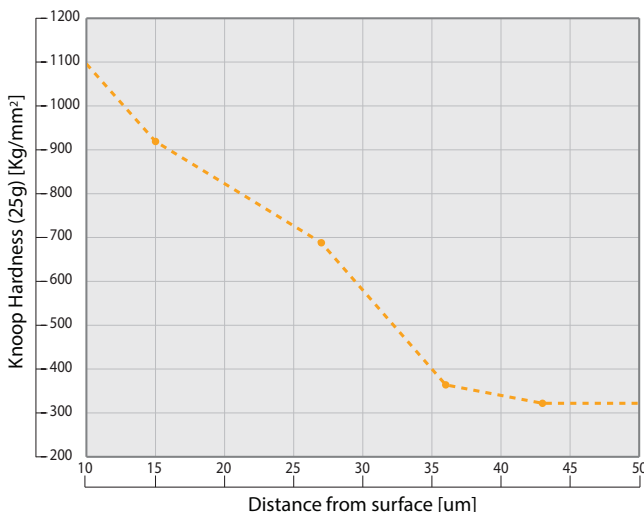
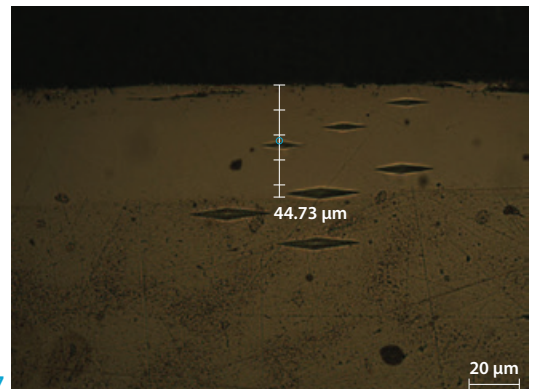

Figure 6

Figure 7



Floating Ball Valves

Metal seated valves

General

Up to
400 °C / 752 °F

Up to
538 °C / 1000 °F

Up to
650 °C / 1200 °F

Ordering
code system

Coatings

Unlike LTPN surface treatment methods where the existing surface is changed by diffusion, surface coating applies an outer layer of new material on the surface. The following types of surface coating methods are available in the Habonim metal seated series: chromium carbide with nickel chrome binder (Cr₃C₂), tungsten carbide with cobalt binder (WC-Co), and stellite welding.

Cr₃C₂ (Chromium Carbide)

Chromium carbide with a nickel chrome binder is applied by a High Velocity Oxygen Fuel (HVOF) creating a 0.3mm hard outer layer. The Cr₃C₂ coating that is applied to high strength steels, results in a micro-hardness of up to 68HRC. This coating resists cryogenic temperatures down to -196 °C / -320 °F and high temperatures up to 815 °C / 1500 °F (all temperatures above 650 °C / 1200 °F refer to the coating or bolts performance only and not to the valve design). This multipurpose wear resistance coating is used extensively in power generation, refining and hot catalyst handling services. Its corrosive limitations are in wet sulfur or chloride environments, where sulfuric acid can form and attack the coating.

WC-Co (Tungsten Carbide)

Tungsten Carbide with a cobalt binder coating is applied by HVOF techniques similar to Cr₃C₂. The WC-Co coating is applied mainly to 400 series martensitic stainless steel to provide micro-hardness that reaches 72HRC. This coating resists cryogenic temperatures down to -196 °C / -320 °F and high temperatures up to 538 °C / 1000 °F. WC-Co is a coating that consists of a hard metal alloy based on a Tungsten Carbide + Cobalt composition.

Stellite 6

A cobalt-based stellite coating provides excellent mechanical wear resistance, with good corrosion resistance at temperatures up to 538 °C / 1000 °F. The stellite is applied by a Plasma Thermal Arc (PTA) method. Most stellite alloys are cobalt based with elements of chromium (Cr), carbon (C), tungsten (W) and nickel (Ni). Stellite 6 is broadly used in the pulp and paper industry, as well as in refining applications, such as catalyst handling and hydrocracker processes.

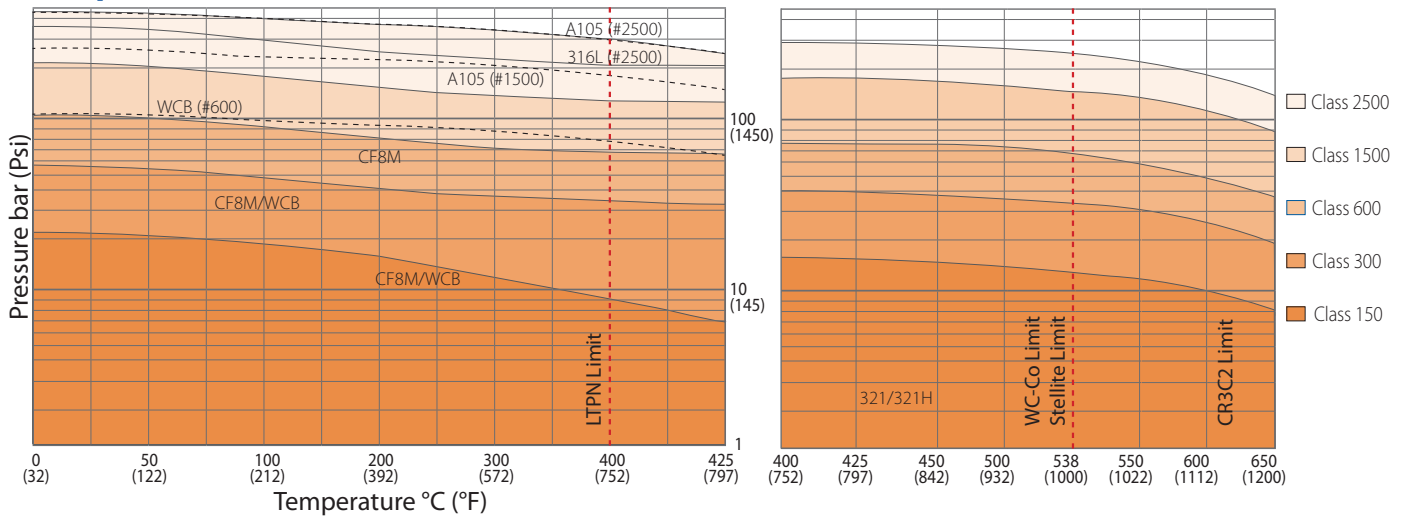

Figure 8
Hard coating done by HVOF technology

Surface Treatments/ Coatings	Process Method	Process Material	Coating Thickness	Min. Hardness	Max Temp*	Corrosion Resistance
LTPN	Plasma carboNitriding	Nitrogen, Carbon	25-80 µm	72HRC	See fig.1	Excellent
Cr ₃ C ₂	HVOF spray	Chromium, Carbon Nickel	0.3 mm	68HRC	815 °C / 1500 °F	Good
DN WC-Co 40	HVOF spray	Tungsten, Carbon Cobalt	0.3 mm	72HRC	538 °C / 1000 °F	Excellent
Stellite	PTA (Plasma Thermal Arc)	Cobalt-Ni	3 mm	36HRC	538 °C / 1000 °F	Good

*All temperatures above 650 °C/1200 °F refer to the coating performance only and not to the valve design

Temperature vs Pressure



Temperature vs Pressure (bar) - Standard class rating

ASME B16.34	Material	Temperature (°C)										
		-29 to 38	50	100	200	300	400	450	500	538	600	650
Class 150	316/316L	15.9	15.3	13.3	11.2	10.0	6.5	4.6				
	CF8M/CF3M	19.0	18.4	16.2	13.7	10.2	6.5	4.6	2.8	1.4		
	WCB/A105/LF2	19.6	19.2	17.7	13.8	10.2	6.5	4.6	2.8	1.4		
	F22	19.8	19.5	17.7	13.8	10.2	6.5	4.6	2.8	1.4	1.4	
Class 300	321/321H	19.0	18.6	17.0	13.8	10.2	6.5	4.6	2.8	1.4	1.4	
	316/316L	41.4	40.0	34.8	29.2	26.1	24.3	23.4				
	CF8M/CF3M	49.6	48.1	42.2	35.7	31.6	29.4	28.8	28.2	25.2		
	WCB/A105/LF2	51.1	50.1	46.6	43.8	39.8	34.7	23.0	11.8	5.9		
Class 600	321/321H	49.6	48.6	44.2	38.3	34.1	31.6	30.8	28.2	25.2	20.3	
	316/316L	82.7	80.0	69.6	58.1	52.1	48.6	46.8				
	CF8M/CF3M	99.3	96.2	84.4	71.3	63.2	58.9	57.7	56.5	50.0		
	WCB/A105/LF2	102.1	100.2	93.2	87.6	79.6	69.4	46.0	23.5	11.8		
Class 900	F22	103.4	103.4	103.0	97.2	85.7	73.3	67.7	56.5	36.9	13.8	
	321/321H	99.3	97.1	88.5	76.6	68.3	63.2	61.7	56.5	50.0	40.5	
	316/316L	124.1	120.1	104.4	87.5	78.2	72.9	70.2				
	A105/LF2	153.2	150.4	139.8	131.4	119.5	104.2	69.0	35.3	17.7		
Class 1500	F22	155.1	155.1	154.6	145.8	128.6	109.8	101.4	84.7	55.3	20.7	
	321/321H	148.9	145.7	132.7	114.9	102.4	94.8	92.5	84.7	75.2	60.8	
	316/316L	206.8	200.1	173.9	145.8	130.3	121.5	117.1				
	A105/LF2	255.3	250.6	223.0	219.0	199.1	173.6	115.0	58.8	29.5		
Class 2500	F22	258.6	258.6	257.6	243.4	214.4	183.1	169.0	140.9	92.2	34.4	
	321/321H	248.2	242.8	221.2	191.5	170.7	157.9	154.2	140.9	125.5	101.3	
	316/316L	344.7	333.5	289.9	243.0	217.2	202.5	195.1				
	A105/LF2	425.5	417.7	388.3	365.0	331.8	289.3	191.7	97.9	49.2		
	F22	430.9	430.9	429.4	405.4	357.1	304.9	281.8	235.0	153.7	57.4	
	321/321H	413.7	404.6	368.7	319.1	284.6	263.2	256.9	235.0	208.9	168.9	

Temperature vs Pressure (Psi) - Standard class rating

ASME B16.34	Material	Temperature (°F)									
		-20 to 100	122	212	392	572	752	842	932	1000	1112
Class 150	316/316L	231	222	193	162	145	94	67			
	CF8M/CF3M	276	267	235	199	148	94	67	41	20	
	WCB/A105/LF2	284	278	257	200	148	94	67	41	20	
	F22	287	283	257	200	148	94	67	41	20	20
Class 300	321/321H	276	270	247	200	148	94	67	41	20	20
	316/316L	600	580	505	423	378	352	339			
	CF8M/CF3M	719	697	612	518	458	426	418	409	365	
	WCB/A105/LF2	741	726	676	635	577	503	334	171	86	
Class 600	F22	750	750	747	705	622	529	489	409	267	100
	321/321H	719	705	641	555	494	458	447	409	365	294
	316/316L	1199	1160	1009	842	755	705	679			
	CF8M/CF3M	1440	1395	1224	1034	916	854	837	819	725	
Class 900	WCB/A105/LF2	1480	1453	1351	1270	1154	1006	667	341	171	
	F22	1499	1499	1494	1409	1243	1063	982	819	535	200
	321/321H	1440	1408	1283	1111	990	916	895	819	725	587
	316/316L	1799	1741	1514	1269	1134	1057	1018			
Class 1500	A105/LF2	2221	2181	2027	1905	1733	1511	1001	512	257	
	F22	2249	2249	2242	2114	1865	1592	1470	1228	802	300
	321/321H	2159	2113	1924	1666	1485	1375	1341	1228	1090	882
	316/316L	2999	2901	2522	2114	1889	1762	1698			
Class 2500	A105/LF2	3702	3634	3234	3176	2887	2517	1668	853	428	
	F22	3750	3750	3735	3529	3109	2655	2451	2043	1337	499
	321/321H	3599	3521	3207	2777	2475	2290	2236	2043	1820	1469
	316/316L	4998	4836	4204	3524	3149	2936	2829			
Class 2500	A105/LF2	6170	6057	5630	5293	4811	4195	2780	1420	713	
	F22	6248	6248	6226	5878	5178	4421	4086	3408	2229	832
	321/321H	5999	5867	5346	4627	4127	3816	3725	3408	3029	2449

* It is totally forbidden to use a material when pressure rating is missing
 * F22 316L material is not recommended for prolonged use above 595 °C/1100 °F
 * A105, WCB and LF2 materials are not recommended for prolonged use above 425 °C/800 °F
 * 316L and CF3M materials are not to be used above 455 °C/850 °F

Floating Ball Valves

Metal seated valves

General

Up to 400 °C / 752 °F

Up to 538 °C / 1000 °F

Up to 650 °C / 1200 °F

Ordering code system

Size ¼"- 2" | DN8-DN50 | Class 600 | Z47 Series

Valve dimensions

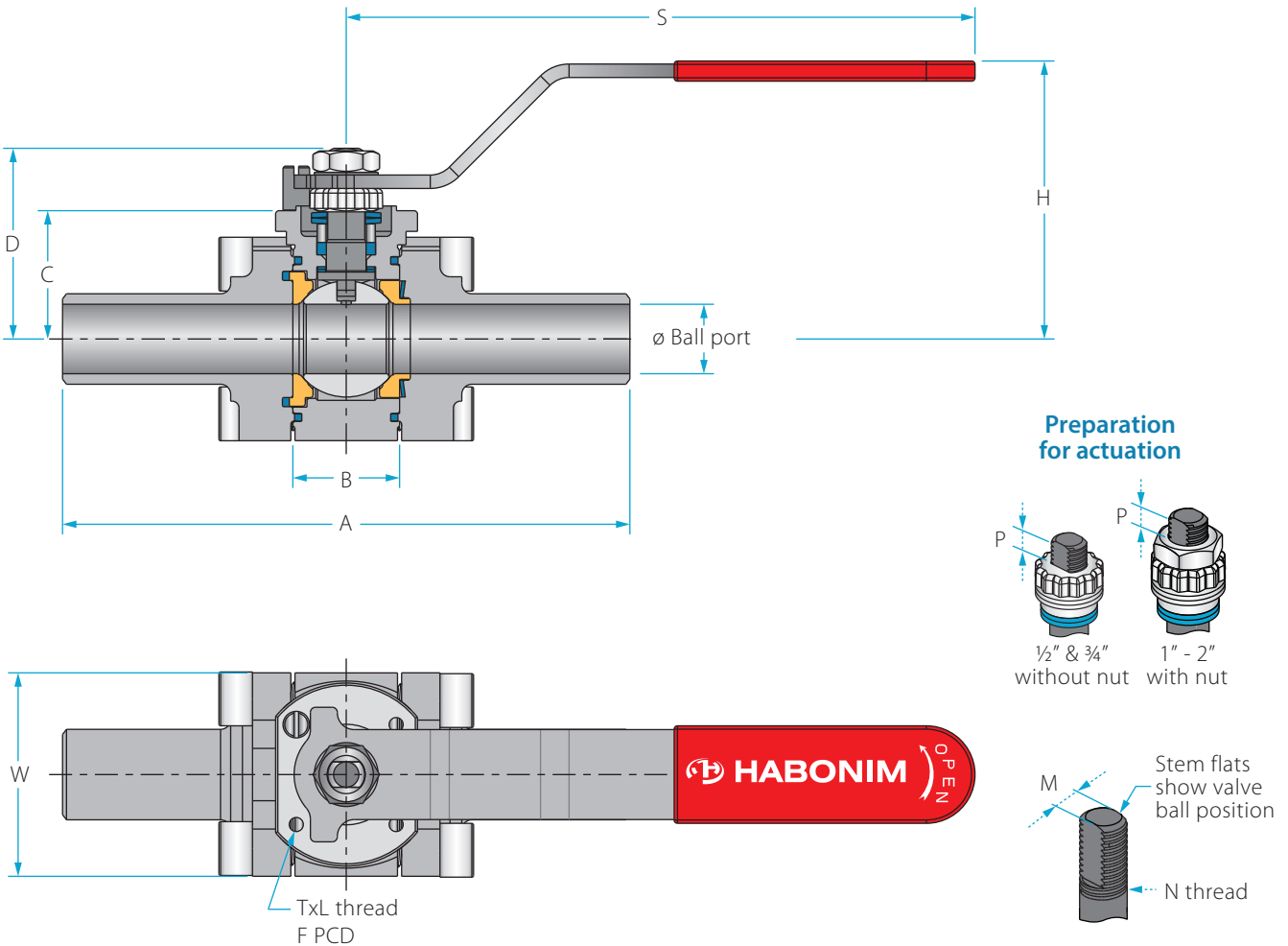

Std. port	Full port	Unit	Ball port	A		B	C	D	H	S	W	M	N	P	F	W	TxL	Weight kg/lb	Kv Cv
				Welded	Threaded														
DN15	DN8, DN10	mm	11.15	140.60	66.00	20.60	29.00	37.90	62.00	150.00	46.00	5.54	¾" UNF	6.65	(F03)	36.00	M5x10	1	6.9
½"	¼", ⅜"	inch	0.44	5.54	2.60	0.81	1.14	1.49	2.44	5.91	1.81	0.22		0.26		1.42		2	8.0
DN20	DN15	mm	14.30	146.95	70.60	24.55	31.40	40.30	64.00	150.00	52.10	5.54	¾" UNF	6.65	(F03)	36.00	M5x10	1	10
¾"	½"	inch	0.56	5.79	2.78	0.97	1.24	1.59	2.52	5.91	2.05	0.22		0.26		1.42		2	12
DN25	DN20	mm	20.65	168.75	94.00	31.75	38.15	55.50	80.00	187.00	60.50	7.54	7/16" UNF	7.40	(F04)	42.00	M5x10	2	28
1"	¾"	inch	0.81	6.64	3.70	1.25	1.50	2.19	3.15	7.36	2.38	0.30		0.29		1.65		4	32
DN32	DN25	mm	25.50	179.25	108.50	41.25	42.65	60.50	84.50	187.00	69.00	7.54	7/16" UNF	7.40	(F04)	42.00	M5x10	3	49
1¼"	1"	inch	1.00	7.06	4.27	1.62	1.68	2.38	3.33	7.36	2.72	0.30		0.29		1.65		6	57
DN40	DN32	mm	31.80	189.40	116.00	48.40	43.50	73.00	96.00	237.00	79.20	8.71	9/16" UNF	8.50	(F05)	50.00	M6x12	3	69
1½"	1¼"	inch	1.25	7.46	4.57	1.91	1.71	2.87	3.78	9.33	3.12	0.34		0.33		1.97		8	80
DN50	DN40	mm	38.10	200.30	128.00	56.30	48.20	77.70	100.00	237.00	90.70	8.71	9/16" UNF	8.50	(F05)	50.00	M6x12	5	102
2"	1½"	inch	1.50	7.89	5.04	2.22	1.90	3.06	3.94	9.33	3.57	0.34		0.33		1.97		11	118

Components & materials

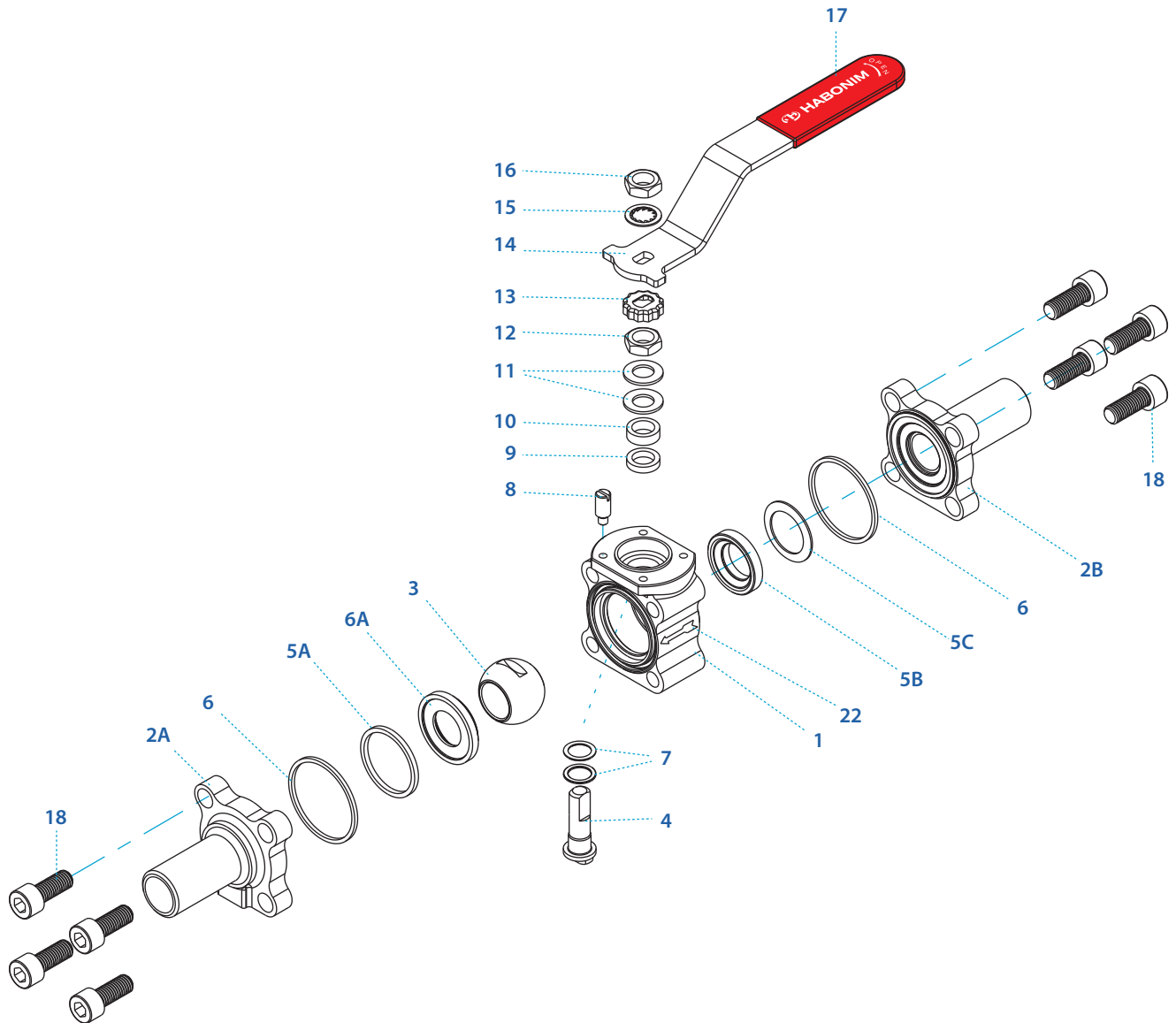

Item	Description	Material specification	Qty.
1	Body	A351 CF8M, A216 WCB, A105, A351 CK3MCuN, A995 CD3MN 4A, A995 CE3MN 5A	1
2A	Downstream end	A351 CF3M, A216 WCB, A105, A351 CK3MCuN, A995 CD3MN 4A, A995 CE3MN 5A	1
2B	Upstream end	A351 CF3M, A216 WCB, A105, A351 CK3MCuN, A995 CD3MN 4A, A995 CE3MN 5A	1
3	Ball	A351 CF8M, A351 CK3MCuN, A995 CD3MN 4A, A995 CE3MN 5A. Hardened with LTPN - Low Temperature Plasma carboNitriding technology	1
4	Stem	A564 Gr.630 H1150D 17-4PH, B637 N07718 Inconel 718	1
5A	Downstream seat	A479 316L, A479 S31254, A479 S31803, A479 S32750. Hardened with LTPN - Low Temperature Plasma carboNitriding technology	1
5B	Upstream seat	A479 316L, A479 S31254, A479 S31803, A479 S32750. Hardened with LTPN - Low Temperature Plasma carboNitriding technology	1
5C	Upstream disc spring	Inconel 718	1
6*	Body seal	Graphite	2

Item	Description	Material specification	Qty.
6A*	Seat seal	Graphite	1
7*	Stem thrust seal	A479 316L Hardened with LTPN - Low Temperature Plasma carboNitriding technology, B637 N07718 Inconel 718	2
8	Stop pin	A582 303	1
9*	Stem seal	Graphite	1
10	Follower	B783 316L	1
11	Disc spring	A693 631 17-7PH	2
12	Stem nut	A194 8M, EN3506-2 A4-80	1
13	Locking clip	A167 304	1
14	Handle	A659 G10200 Zinc plate, A240 430	1
15	Serrated washer	A240 410	1
16	Handle nut	A194 8M, EN3506-2 A4-80	1
17	Sleeve	PVC	1
18	Body bolts	EN 3506-1 A4-80, A193 B8M, A193 B7 zinc plated	8
22	Arrow flow	A167 304	1
23	Tag (not shown)	A167 304	1

* Repair kit components

Floating Ball Valves

Metal seated valves

General

Up to
400 °C / 752 °F

Up to
538 °C / 1000 °F

Up to
650 °C / 1200 °F

Ordering
code system

Size 2½"- 8" | DN65-DN200 | Class 600 | Z47 Series

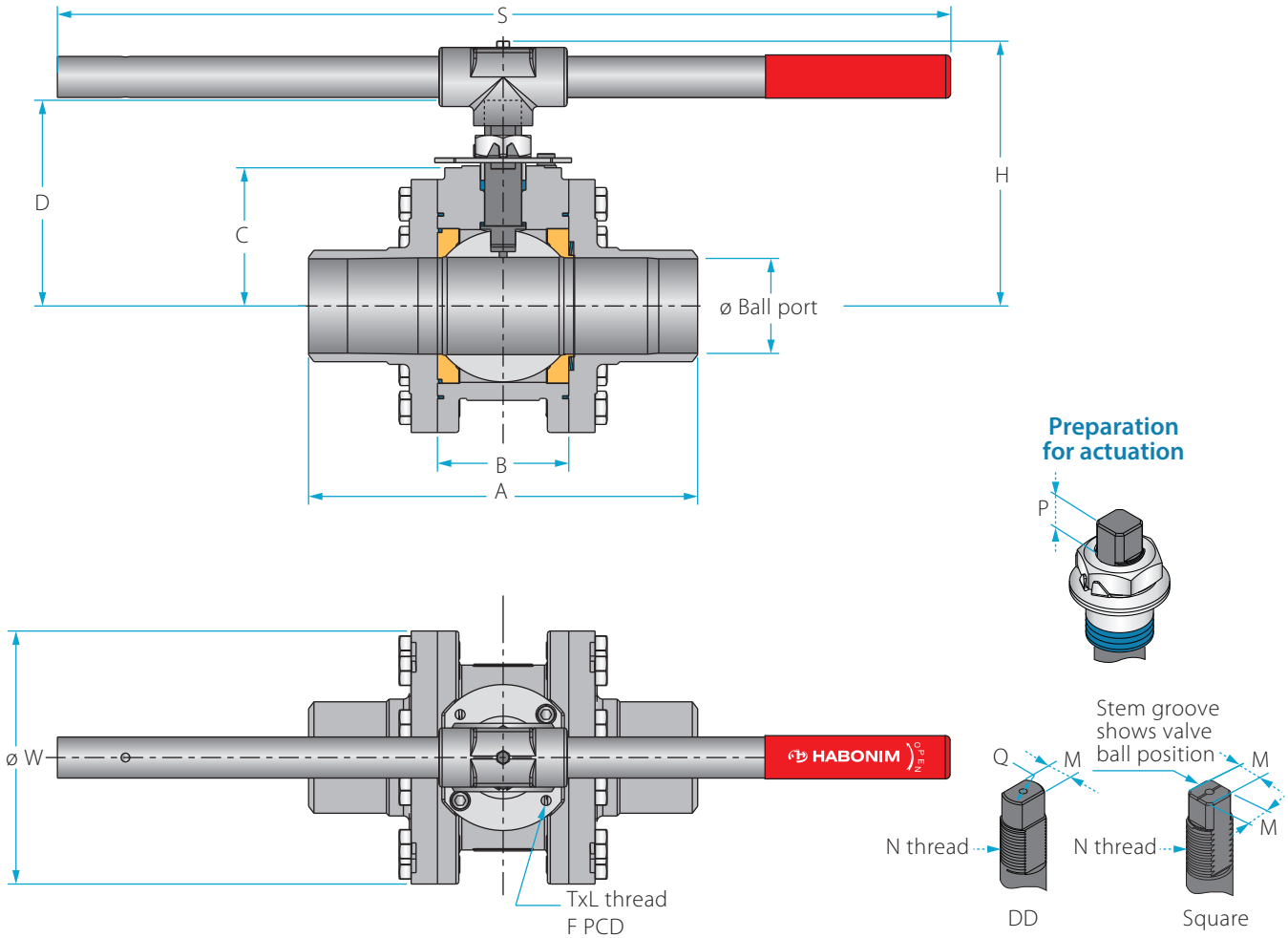

Std. port	Full port	Unit	Ball port	A		B	C	D	H	S	W	M	M (DD)	Q	N	P	F	TxL	Weight kg/lb	Kv Cv
				Welded	Threaded															
DN65	DN50	mm	51.00	200.00	160.00	75.00	87.50	134.00	174.00	401.00	150.00	18.90	15.90	22.70	1"-14	16.70 (F10)	102.00	M10x20	14.20	430
2½"	2"	inch	2.01	7.87	6.30	2.95	3.44	5.28	6.85	15.79	5.91	0.74	0.63	0.89	UNS-2A	0.66	4.02	M10x20	31.24	499
DN80	DN65	mm	63.75	285.00	213.00	108.80	114.10	160.60	201.00	600.00	191.50	18.90	15.90	22.70	1"-14	16.70 (F10)	102.00	M10x20	25.00	1000
3"	2½"	inch	2.51	11.22	8.39	4.28	4.49	6.32	7.91	23.62	7.54	0.74	0.63	0.89	UNS-2A	0.66	4.02	M10x20	55.00	1160
DN100	DN80	mm	80.00	356.00	-	110.00	126.50	195.90	256.6	916.00	210.00	28.45	23.75	35.20	1½"-12	26.20 (F12)	125.00	M12x20	38.00	1830
4"	3"	inch	3.15	14.02	-	4.33	4.98	7.71	10.10	36.06	8.27	1.12	0.94	1.39	UNF-2A	1.03	4.92	M12x20	83.60	2123
DN150	DN100	mm	100.00	395.00	-	135.00	142.40	211.9	-	-	260.00	28.45	23.75	35.20	1½"-12	26.20 (F12)	125.00	M12x20	60.00	4380
6"	4"	inch	3.94	15.55	-	5.31	5.61	8.34	-	-	10.24	1.12	0.94	1.39	UNF-2A	1.03	4.92	M12x20	132.00	5081
DN200	DN150	mm	150.00	490.00	-	190.00	194.00	307	-	-	360.00	35.92	35.92	46.50	2"-8	40.00 (F14)	140.00	M16x20	130.00	8070
8"	6"	inch	5.91	19.29	-	7.48	7.64	12.09	-	-	14.17	1.41	1.41	1.83	UN-2A	1.57	5.51	M16x20	286.00	9361
	DN200	mm	200.00	500.00	-	275.00	245.00	400	-	-	470.00	45.90	45.90	55.00	2¾"-8	50.00 (F16)	165.00	M20x30	315.00	7600
	8"	inch	7.87	19.69	-	10.83	9.65	15.75	-	-	18.50	1.81	1.81	2.17	UN-2A	1.97	6.50	M20x30	693.00	6590

⁽⁴⁾ Due to high valve torque, pipe handle cannot be used. A manual gear or automation means should be used to operate the valve.

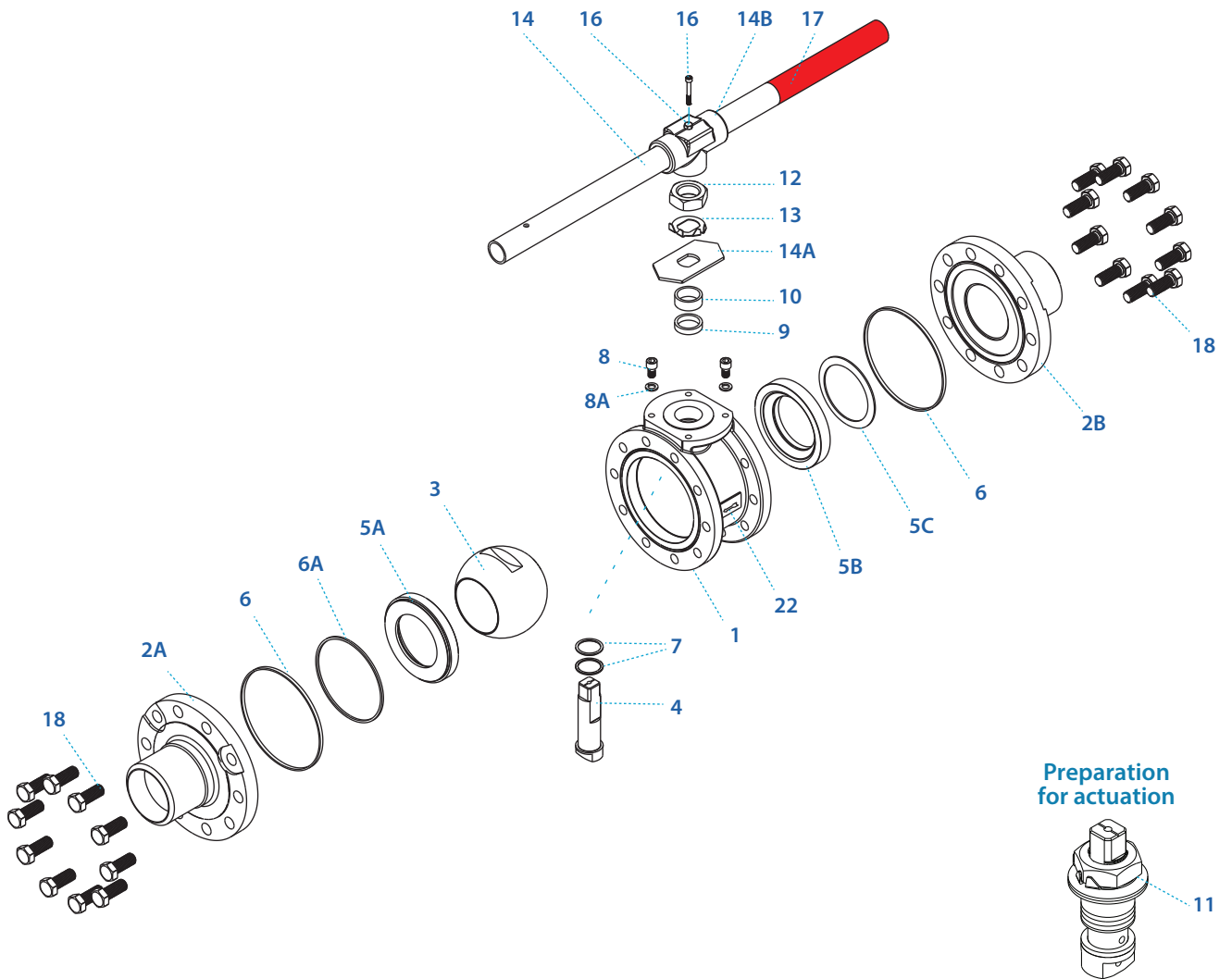

Item	Description	Material specification	Qty.
1	Body	A351 CF8M, A216 WCB, A351 CK3MCuN, A995 CD3MN 4A A995 CE3MN 5A	1
2A	Downstream end	A351 CF3M, A216 WCB, A351 CK3MCuN, A995 CD3MN 4A A995 CE3MN 5A	1
2B	Upstream end	A351 CF3M, A216 WCB, A351 CK3MCuN, A995 CD3MN 4A A995 CE3MN 5A	1
3	Ball	A351 CF8M, A351 CK3MCuN, A995 CD3MN 4A A995 CE3MN 5A. Hardened with LTPN - Low Temperature Plasma carboNitriding technology	1
4	Stem	A564 Gr.630 H1150D 17-4PH, B637 N07718 Inconel 718	1
5A	Downstream seat	A479 316L, A479 S31254, A479 S31803, A479 S32750. Hardened with LTPN - Low Temperature Plasma carboNitriding technology	1
5B	Upstream seat	A479 316L, A479 S31254, A479 S31803, A479 S32750. Hardened with LTPN - Low Temperature Plasma carboNitriding technology	1
5C	Upstream disc spring	Inconel 718	1
6*	Body seal	Graphite	2
6A*	Seat seal	Graphite	1
7*	Stem thrust seal	A479 316L Hardened with LTPN - Low Temperature Plasma carboNitriding technology, B637 N07718 Inconel 718	2

Item	Description	Material specification	Qty.
8	Stop pin	A582 303	1
9*	Stem seal	Graphite	1
10	Follower	B783 316L	1
11	Disc spring	A693 631 17-7PH	2
12	Stem nut	A194 8M, EN3506-2 A4-80	1
13	Tab lock washer	A240 304	1
14**	Handle	C.St. A29 G10200 Zinc plate, A240 430	1
14A	Stop plate	C.St. 1.0402 Zinc plate, A240 430	1
14B	Wrench head	Ductile Iron A536 Gr. 65-45-12, A216 WCB, A351 CF8M	1
16	Wrench bolt	EN3506-1 A2-70/A4-80, A193 Gr B8/B8M	1
17	Sleeve	PVC	1
18	Body bolts	EN 3506-1 A4-80, A193 B8M, A193 B7 zinc plated	20-32
22	Arrow flow	A167 304	1
23	Tag (not shown)	A167 304	1

* Repair kit components

** Gear operator should be used for size 6" DN150 and above (handle components are not included)

Floating Ball Valves

Metal seated valves

General

Up to
400 °C / 752 °F

Up to
538 °C / 1000 °F

Up to
650 °C / 1200 °F

Ordering
code system

Size ½"- 1½" | DN15-DN40 | Class 150/300 | Z73/Z74 Series

Valve dimensions

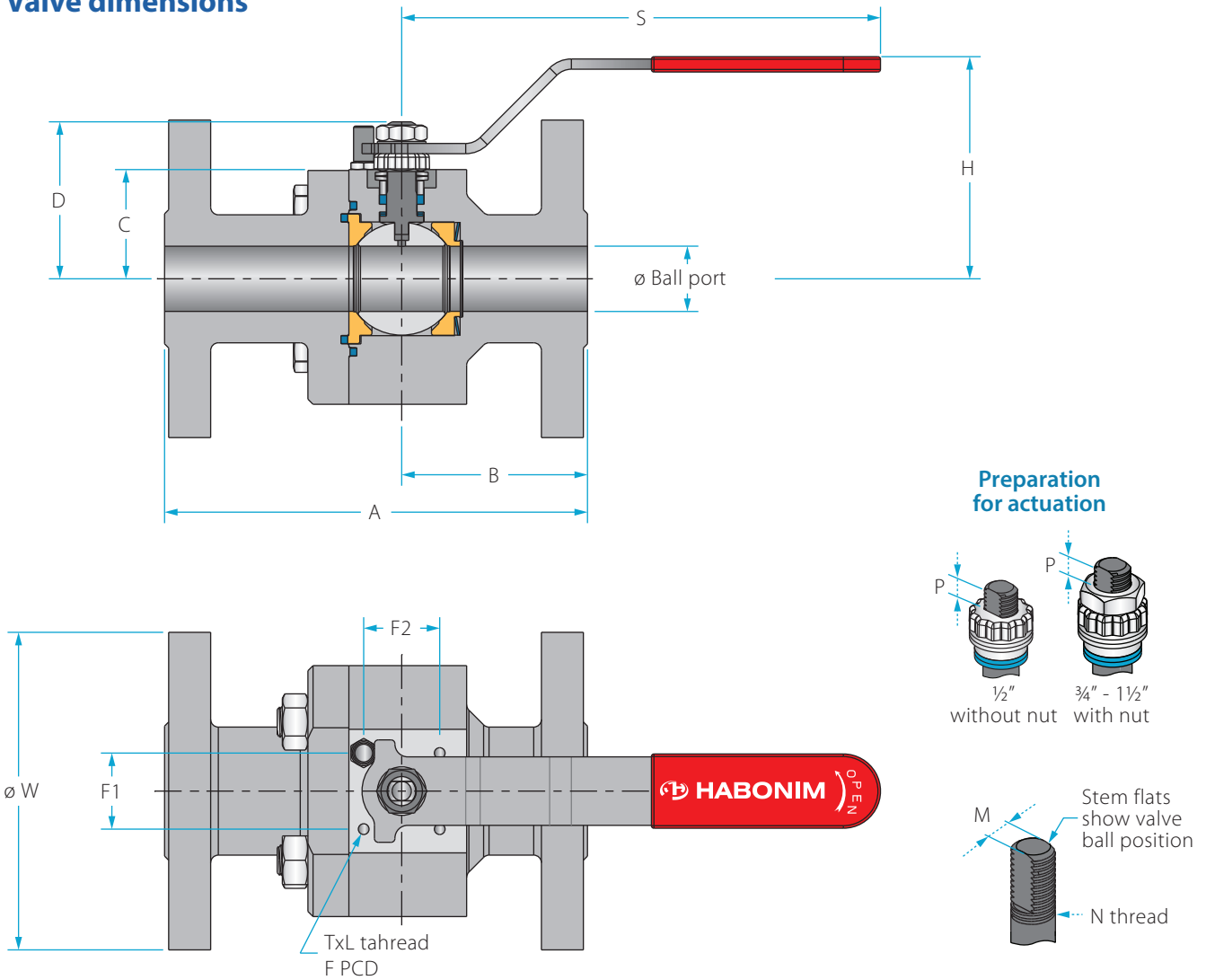

Std. port	Unit	Ball port	A		B		C	D	H	S	W		M	N	P	F	TxL	Weight kg/lb		Kv Cv
			150	300	150	300					150	300								
DN15	mm	14.30	108.00	139.70	49.00	60.00	29.40	40.40	92.00	151.00	89.00	95.00	5.54	¾" UNF	6.65 (F03)	36.00	M5x10	2.70	4	28
½"	inch	0.56	4.25	5.50	1.93	2.36	1.16	1.59	3.62	5.94	3.50	3.74	0.22		0.26	1.42		6.00	9	32
DN20	mm	20.65	117.00	152.00	58.00	65.00	38.20	55.70	103.50	170.00	98.00	117.00	7.54	7/16" UNF	7.40 (F04)	42.00	M5x10	4.00	5	46
¾"	inch	0.81	4.61	5.98	2.28	2.56	1.50	2.19	4.07	6.69	3.86	4.61	0.30		0.29	1.65		8.80	12	53
DN25	mm	25.50	127.00	165.00	55.00	73.00	42.65	60.20	108.00	170.00	108.00	124.00	7.54	7/16" UNF	7.40 (F04)	42.00	M5x10	5.40	7	80
1"	inch	1.00	5.00	6.50	2.17	2.87	1.68	2.37	4.25	6.69	4.25	4.88	0.30		0.29	1.65		11.90	15	93
DN40	mm	38.10	165.00	190.00	68.00	80.40	48.20	77.70	124.00	220.50	127.00	156.00	8.71	9/16" UNF	8.50 (F05)	50.00	M6x12	7.20	10	220
1½"	inch	1.50	6.50	7.48	2.68	3.17	1.90	3.06	4.88	8.68	5.00	6.14	0.34		0.33	1.97		15.90	23	255

Components & materials

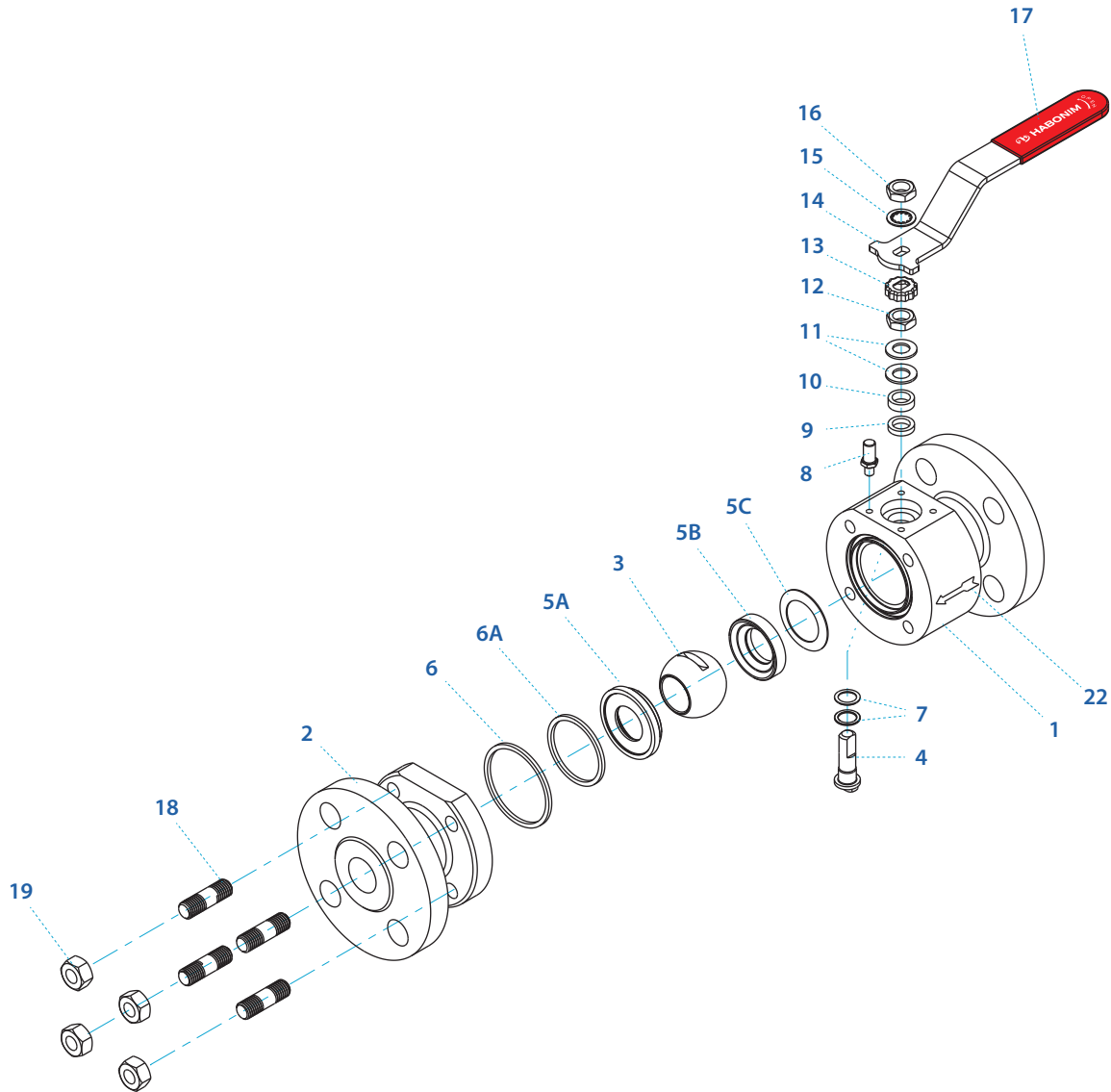

Item	Description	Material specification	Qty.
1	Body	A479 316L, A479 S31254, A479 S31803, A479 S32750, A350 LF2,	1
2	End	A479 316L, A479 S31254, A479 S31803, A479 S32750, A350 LF2	1
3	Ball	A351 CF8M, A351 CK3MCuN, A995 CD3MN 4A, A995 CE3MN 5A. Hardened with LTPN - Low Temperature Plasma carboNitriding technology	1
4	Stem	A564 Gr.630 H1150D 17-4PH, B637 N07718 Inconel 718	1
5A	Upstream seat	A479 316L, A479 S31254, A479 S31803, A479 S32750. Hardened with LTPN - Low Temperature Plasma carboNitriding technology	1
5B	Downstream seat	A479 316L, A479 S31254, A479 S31803, A479 S32750. Hardened with LTPN - Low Temperature Plasma carboNitriding technology	1
5C	Upstream disc spring	Inconel 718	1
6*	Body seal	Graphite	1
6A*	Seat seal	Graphite	1
7*	Stem thrust seal	A479 316L Hardened with LTPN - Low Temperature Plasma carboNitriding technology, B637 N07718 Inconel 718	2

Item	Description	Material specification	Qty.
8	Stop pin	A582 303	1
9*	Stem seal	Graphite	1
10	Follower	B783 316L	1
11	Disc spring	A693 631 17-7PH	2
12	Stem nut	A194 8M, EN3506-2 A4-80	1
13	Locking clip	A167 304	1
14	Handle	A659 G10200 Zinc plate, A240 430	1
15	Serrated washer	A240 410	1
16	Handle nut	A194 8M, EN3506-2 A4-80	1
17	Sleeve	PVC	1
18	Body bolts/studs	EN 3506-1 A4-80, A193 B8M, A193 B7 zinc plated	4
19	Body nut	EN 3506-2 A4-80, A194 B8, A194 7 zinc plated	4
22	Arrow flow	A167 304	1
23	Tag (not shown)	A167 304	1

* Repair kit components

Floating Ball Valves

Metal seated valves

General

Up to
400 °C / 752 °F

Up to
538 °C / 1000 °F

Up to
650 °C / 1200 °F

Ordering
code system

Size 2"- 8" | DN50-DN200 | Class 150/300 | Z73/Z74 Series

Valve dimensions

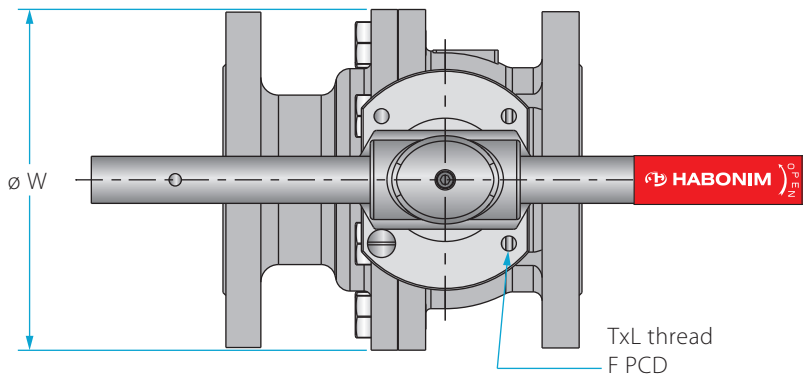
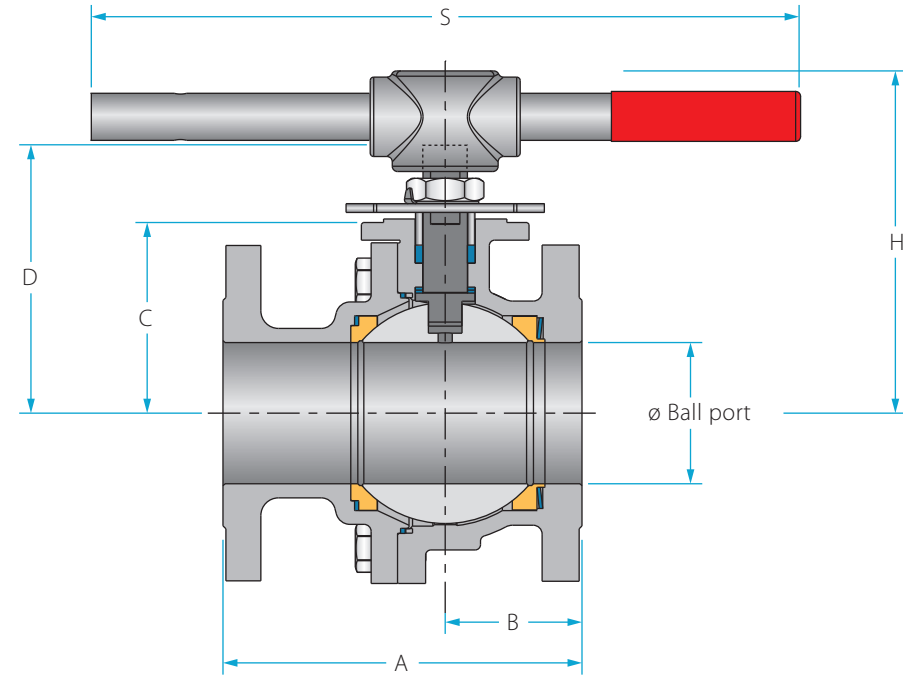

Preparation for actuation

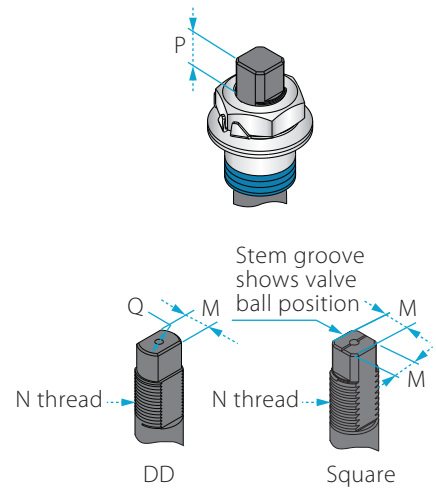

Std. port	Unit	Ball port	A		B		C	D	H	S	W		M	M (DD)	Q	N	P	F	TxL	Weight kg/lb		Kv Cv
			150	300	150	300					150	300										
DN50	mm	50.05	178.00	216.00	69.00	75.10	70.00	111.60	137.30	256.00	152.00	165.00	-	13.90	20.00	M20x2.5	14.60 (F07)	70.00	M8X12	11	14	430
2"	inch	1.97	7.01	8.50	2.72	2.96	2.76	4.39	5.41	10.08	5.98	6.50	-	0.55	0.79		0.57	2.76		25	31	499
DN80	mm	80.00	203.00	282.50	77.50	96.40	108.00	154.60	194.80	610.00	191.00	210.00	18.90	15.90	22.70	1"-14 UNF-2A	16.70 (F10)	102.00	M10X20	22	28	1000
3"	inch	3.15	7.99	11.12	3.05	3.80	4.25	6.09	7.67	24.00	7.52	8.27	0.74	0.63	0.89		0.66	4.02		48	62	1160
DN100	mm	100.00	228.50	304.80	84.50	104.50	124.00	210.80	-	-	230.00	254.00	18.90	15.90	22.70	1"-14 UNF-2A	16.70 (F10)	102.00	M12X20	39	44	1830
4"	inch	3.94	9.00	12.00	3.33	4.11	4.88	8.30	-	-	9.06	10.00	0.74	0.63	0.89		0.66	4.02		86	98	2123
DN150	mm	150.00	394.00	403.50	163.50	174.50	179.00	248.50	-	-	328.00	328.00	28.45	23.75	35.20	1½"-12 UNF-2A	26.20 (F12)	125.00	M12x20	82	100	4380
6"	inch	5.91	15.51	15.89	6.44	6.87	7.05	9.78	-	-	12.91	12.91	1.12	0.94	1.39		1.03	4.92		181	220	5081
DN200	mm	200.00	457.20	501.80	242.50	240.70	241.00	353.70	-	-	450.00	450.00	35.92	35.92	46.50	2"-8 UN-2A	37.50 (F14)	140.00	M16X30	190	225	8070
8"	inch	7.87	18.00	19.75	9.55	9.48	9.49	13.93	-	-	17.72	17.72	1.41	1.41	1.83		1.48	5.51		419	496	9361

^{h)} Due to high valve torque, pipe handle cannot be used. A manual gear or automation means should be used to operate the valve.

Components & materials

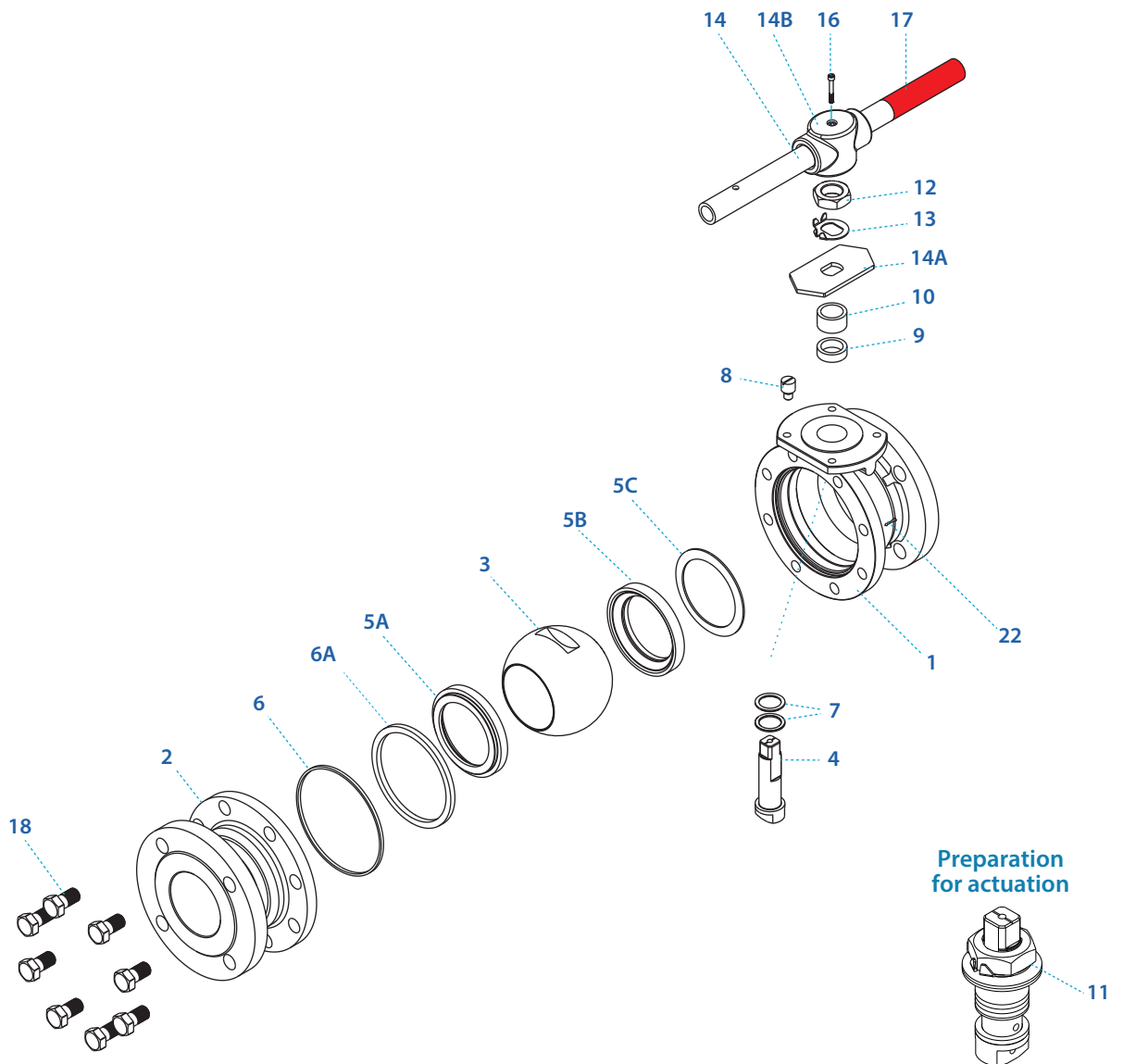

Item	Description	Material specification	Qty.
1	Body	A351 CF8M, A216 WCB, A351 CK3MCuN, A995 CD3MN 4A , A995 CE3MN 5A	1
2	End	A351 CF8M, A216 WCB, A351 CK3MCuN, A995 CD3MN 4A , A995 CE3MN 5A	1
3	Ball	A351 CF8M, A351 CK3MCuN, A995 CD3MN 4A, A995 CE3MN 5A. Hardened with LTPN - Low Temperature Plasma carboNitriding technology	1
4	Stem	A564 Gr.630 H1150D 17-4PH, B637 N07718 Inconel 718	1
5A	Downstream seat	A479 316L, A479 S31254, A479 S31803, A479 S32750. Hardened with LTPN - Low Temperature Plasma carboNitriding technology	1
5B	Upstream seat	A479 316L, A479 S31254, A479 S31803, A479 S32750. Hardened with LTPN - Low Temperature Plasma carboNitriding technology	1
5C	Upstream disc spring	Inconel 718	1
6*	Body seal	Graphite	1
6A*	Seat seal	Graphite	1
7*	Stem thrust seal	A479 316L Hardened with LTPN - Low Temperature Plasma carboNitriding technology, B637 N07718 Inconel 718	2

Item	Description	Material specification	Qty.
8	Stop pin	A582 303	1
9*	Stem seal	Graphite	1
10	Follower	B783 316L	1
11	Disc spring	A693 631 17-7PH	2
12	Stem nut	A194 8M, EN3506-2 A4-80	1
13	Tab lock washer	A240 304	1
14**	Handle	C.St. A29 G10200 Zinc plate, A240 430	1
14A	Stop plate	C.St. 1.0402 Zinc plate, A240 430	1
14B	Wrench head	Ductile Iron A536 Gr. 65-45-12, A216 WCB, A351 CF8M	1
16	Wrench bolt	EN3506-1 A2-70/A4-80, A193 Gr B8/B8M	1
17	Sleeve	PVC	1
18	Body bolts	EN 3506-1 A4-80, A193 B8M, A193 B7 zinc plated	8-12
22	Arrow flow	A167 304	1
23	Tag (not shown)	A167 304	1

* Repair kit components

** Gear operator should be used for size 4" DN100 and above (handle components are not included)

Floating Ball Valves

Metal seated valves

General

Up to
400 °C / 752 °F

Up to
538 °C / 1000 °F

Up to
650 °C / 1200 °F

Ordering
code system

Size ½"- 1½" | DN15-DN40 | PN40 | Z78 Series

Valve dimensions

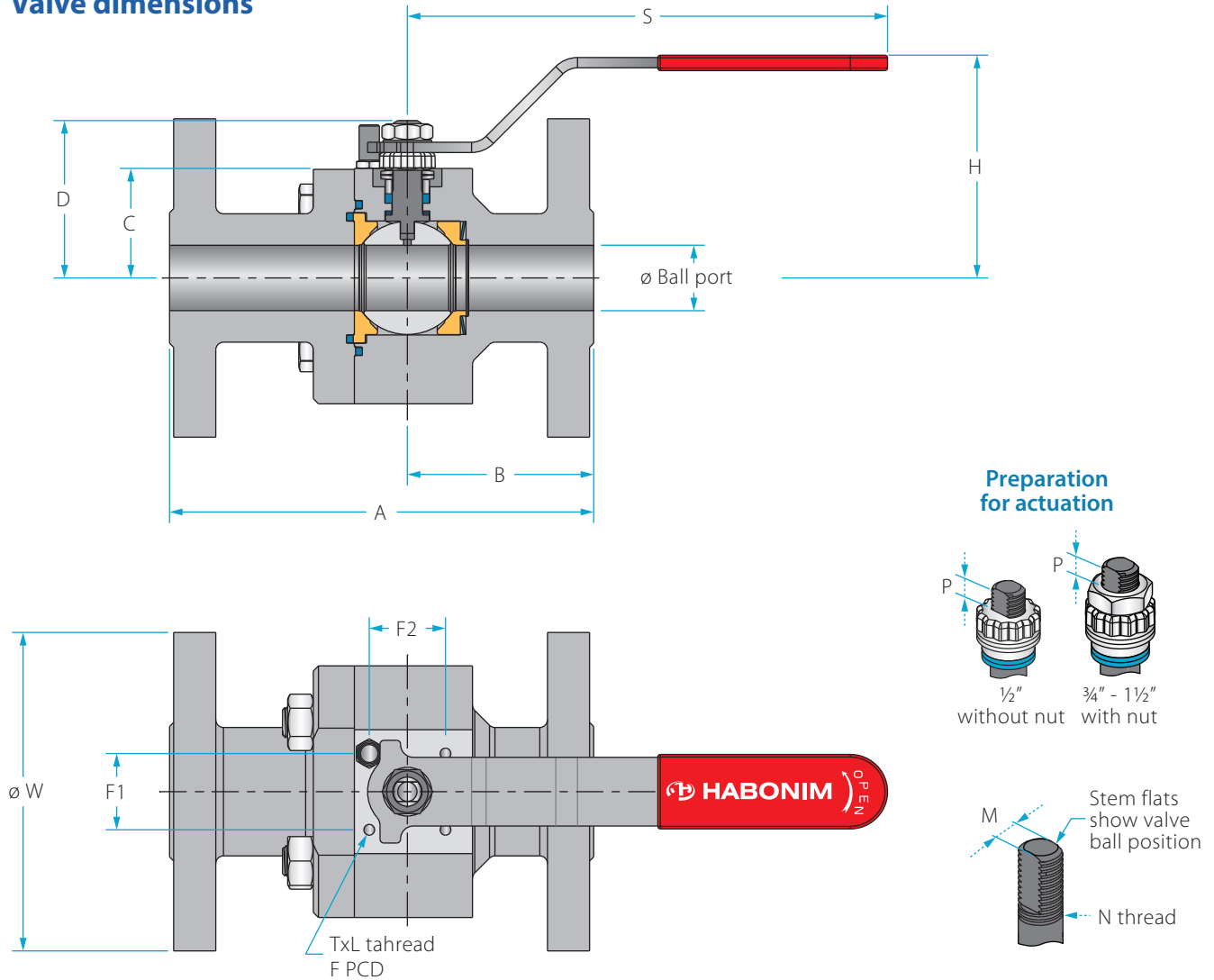

Std. port	Unit	Ball port	A	B	C	D	H	S	W	M	N	P	F	TxL	Weight kg/lb	Cv	
DN15	mm	14.30	130.00	49.00	29.40	38.40	92.00	151.00	95.00	5.54	3/8" UNF	6.65	(F03)	36.00	M5x10	3	28
½"	inch	0.56	5.11	1.93	1.16	1.51	3.62	5.94	3.74	0.22		0.26	1.42	7		32	
DN20	mm	20.65	150.00	58.00	38.20	55.70	103.50	170.00	105.00	7.54	7/16" UNF	7.40	(F04)	42.00	M5x10	4	46
¾"	inch	0.81	5.90	2.28	1.50	2.19	4.07	6.69	4.13	0.30		0.29	1.65	9		53	
DN25	mm	25.50	160.00	55.00	42.65	60.20	108.00	170.00	115.00	7.54	7/16" UNF	7.40	(F04)	42.00	M5x10	6	80
1"	inch	1.00	6.30	2.17	1.68	2.37	4.25	6.69	4.53	0.30		0.29	1.65	13		93	
DN40	mm	38.10	140.00	65.90	48.20	77.70	124.00	220.50	150.00	8.71	9/16" UNF	8.50	(F05)	50.00	M6x12	8	220
1½"	inch	1.50	5.51	2.59	1.90	3.06	4.88	8.68	5.91	0.34		0.33	1.97	18		255	

Components & materials

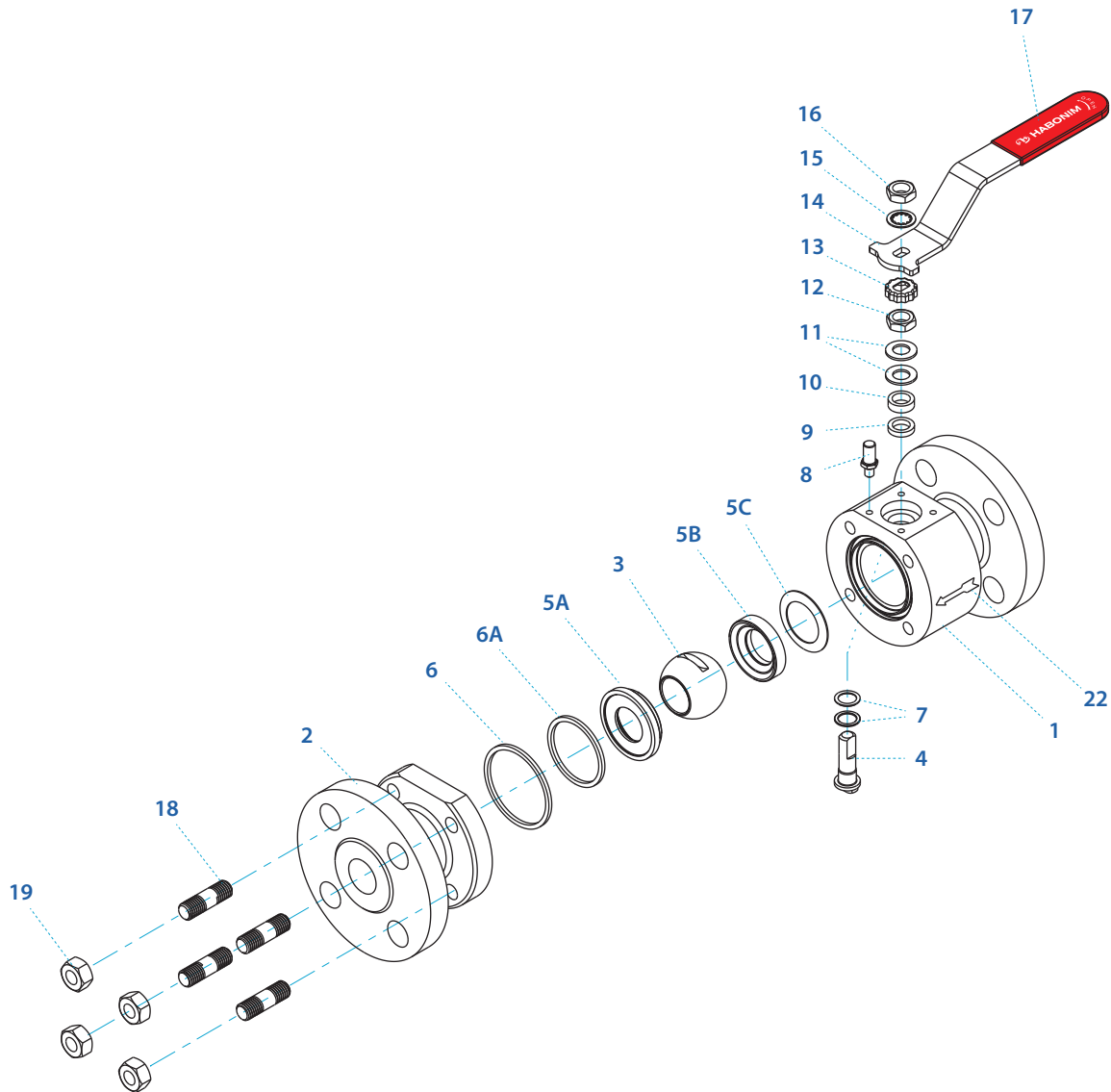

Item	Description	Material specification	Qty.
1	Body	A479 316L, A479 S31254, A479 S31803, A479 S32750, A350 LF2,	1
2	End	A479 316L, A479 S31254, A479 S31803, A479 S32750, A350 LF2	1
3	Ball	A351 CF8M, A351 CK3MCuN, A995 CD3MN 4A, A995 CE3MN 5A. Hardened with LTPN - Low Temperature Plasma carboNitriding technology	1
4	Stem	A564 Gr.630 H1150D 17-4PH, B637 N07718 Inconel 718	1
5A	Upstream seat	A479 316L, A479 S31254, A479 S31803, A479 S32750. Hardened with LTPN - Low Temperature Plasma carboNitriding technology	1
5B	Downstream seat	A479 316L, A479 S31254, A479 S31803, A479 S32750. Hardened with LTPN - Low Temperature Plasma carboNitriding technology	1
5C	Upstream disc spring	Inconel 718	1
6*	Body seal	Graphite	1
6A*	Seat seal	Graphite	1
7*	Stem thrust seal	A479 316L Hardened with LTPN - Low Temperature Plasma carboNitriding technology, B637 N07718 Inconel 718	2

Item	Description	Material specification	Qty.
8	Stop pin	A582 303	1
9*	Stem seal	Graphite	1
10	Follower	B783 316L	1
11	Disc spring	A693 631 17-7PH	2
12	Stem nut	A194 8M, EN3506-2 A4-80	1
13	Locking clip	A167 304	1
14	Handle	A659 G10200 Zinc plate, A240 430	1
15	Serrated washer	A240 410	1
16	Handle nut	A194 8M, EN3506-2 A4-80	1
17	Sleeve	PVC	1
18	Body bolts/studs	EN 3506-1 A4-80, A193 B8M, A193 B7 zinc plated	4
19	Body nut	EN 3506-2 A4-80, A194 B8, A194 7 zinc plated	4
22	Arrow flow	A167 304	1
23	Tag (not shown)	A167 304	1

* Repair kit components

Floating Ball Valves

Metal seated valves

General

Up to
400 °C / 752 °F

Up to
538 °C / 1000 °F

Up to
650 °C / 1200 °F

Ordering
code system

Size 2" | DN50 | PN40 | Z78 Series

Size 3"- 6" | DN80-DN150 | PN16 | Z77 Series

Valve dimensions

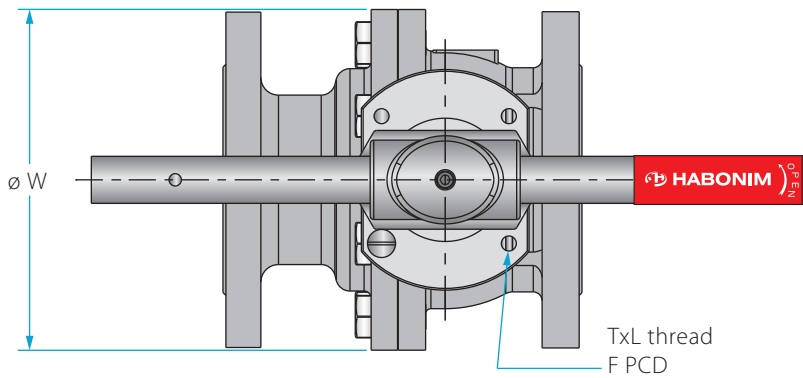
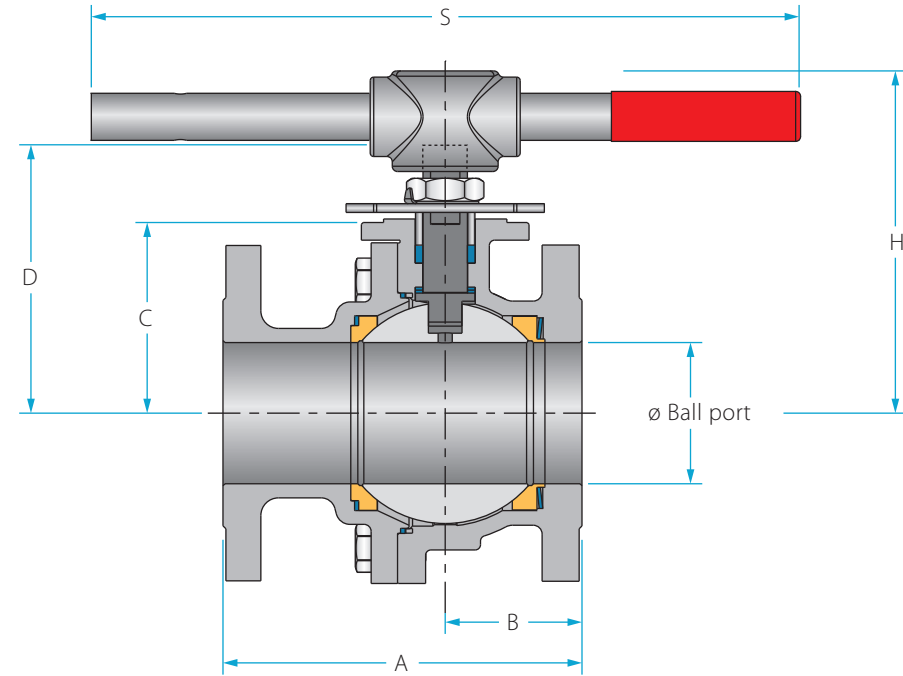

Preparation for actuation

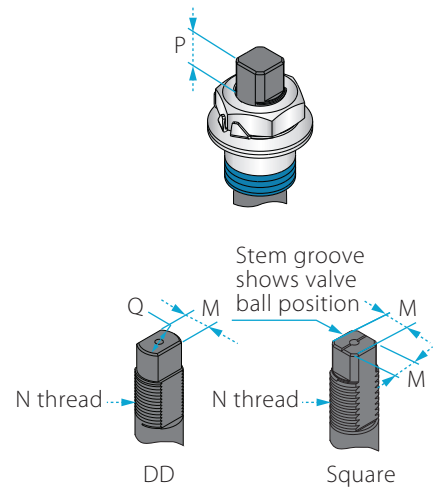

Std. port	Unit	Ball port	A	B	C	D	H	S	W	M	M (DD)	Q	N	P	F	TxL	Weight kg/lb	Cv	
DN50	mm	50.05	150.00	60.70	70.00	111.60	137.30	256.00	165.00	-	13.90	20.00	M20x2.5	14.60	(F07)	70.00	M8X12	11	430
2"	inch	1.97	5.91	2.39	2.76	4.39	5.41	10.08	6.50	-	0.55	0.79		0.57		2.76			25
DN80	mm	80.00	180.00	77.50	108.00	154.60	194.80	610.00	200.00	18.90	15.90	22.70	1"-14 UNF-2A	16.70	(F10)	102.00	M10X20	24	1000
3"	inch	3.15	7.09	3.05	4.25	6.09	7.67	24.00	7.87	0.74	0.63	0.89		0.66		4.02			53
DN100	mm	100.00	190.00	84.50	124.00	210.80	-	-	225.00	18.90	15.90	22.70	1"-14 UNF-2A	16.70	(F10)	102.00	M10X20	31	1830
4"	inch	3.94	7.48	3.33	4.88	8.30	-	-	8.86	0.74	0.63	0.89		0.66		4.02			69
DN150	mm	150.00	350.00	163.50	179.00	248.50	-	-	328.00	28.45	23.75	35.20	1½"-12 UNF-2A	26.20	(F12)	125.00	M12X20	78	4380
6"	inch	5.91	13.78	6.44	7.05	9.78	-	-	12.91	1.12	0.94	1.39		1.03		4.92			172

^{h)} Due to high valve torque, pipe handle cannot be used. A manual gear or automation means should be used to operate the valve.

Size 2" | DN50 | PN40 | Z78 Series
 Size 3"- 6" | DN80-DN150 | PN16 | Z77 Series

Components & materials

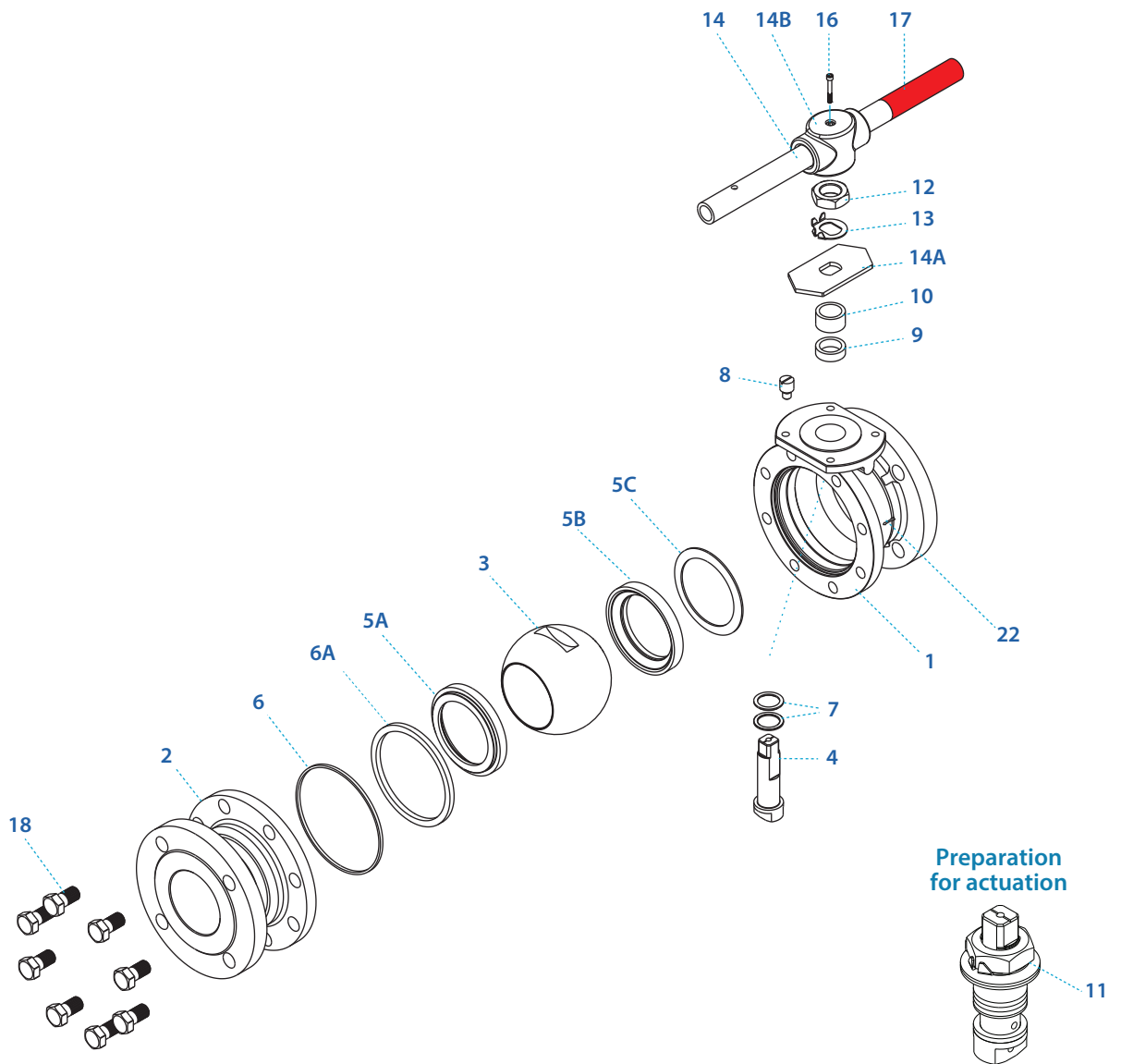

Item	Description	Material specification	Qty.
1	Body	X2CrNiMo 17 13 2 (1.4404), GS-C25 (DIN1.0619), NiCr20CuMo (2.4660), NiCu30Fe (2.4360), NiCr16Mo15W(2.4819), NiCr21Mo14W(2.4602), X1CrNiMoCuN20-18-7 (1.4547), X2CrNiMoN 22-5-3 (1.4462), X2CrNiMoN25-7-4 (1.4410), A216 WCB, A351 CF8M	1
2	End	A351 CF8M, A351 CK3MCuN, A995 CD3MN 4A, A995 CE3MN 5A. Hardened with LTPN - Low Temperature Plasma carboNitriding technology	1
3	Ball	A351 CF8M, A351 CK3MCuN, A995 CD3MN 4A, A995 CE3MN 5A. Hardened with LTPN - Low Temperature Plasma carboNitriding technology	1
4	Stem	A564 Gr.630 H1150D 17-4PH, B637 N07718 Inconel 718	1
5A	Downstream seat	A479 316L, A479 S31254, A479 S31803, A479 S32750. Hardened with LTPN - Low Temperature Plasma carboNitriding technology	1
5B	Upstream seat	A479 316L, A479 S31254, A479 S31803, A479 S32750. Hardened with LTPN - Low Temperature Plasma carboNitriding technology	1
5C	Upstream disc spring	Inconel 718	1
6*	Body seal	Graphite	1
6A	Seat seal	Graphite	1
7*	Stem thrust seal	A479 316L Hardened with LTPN - Low Temperature Plasma carboNitriding technology, B637 N07718 Inconel 718	2

Item	Description	Material specification	Qty.
8	Stop pin	A582 303	1
9*	Stem seal	Graphite	1
10	Follower	B783 316L	1
11	Disc spring	A693 631 17-7PH	2
12	Stem nut	A194 8M, EN3506-2 A4-80	1
13	Tab lock washer	A240 304	1
14**	Handle	C.St. A29 G10200 Zinc plate, A240 430	1
14A	Stop plate	C.St. 1.0402 Zinc plate, A240 430	1
14B	Wrench head	Ductile Iron A536 Gr. 65-45-12, A216 WCB, A351 CF8M	1
16	Wrench bolt	EN3506-1 A2-70/A4-80, A193 Gr B8/B8M	1
17	Sleeve	PVC	1
18	Body bolts	EN 3506-1 A4-80, A193 B8M, A193 B7 zinc plated	8-12
22	Arrow flow	A167 304	1
23	Tag (not shown)	A167 304	1

* Repair kit components
 ** Gear operator should be used for size 4" DN100 and above (handle components are not included)

Floating Ball Valves

Metal seated valves

General

Up to
400 °C / 752 °F

Up to
538 °C / 1000 °F

Up to
650 °C / 1200 °F

Ordering
code system

Size 1/4"- 1 1/4" | DN8-DN32 | Class 2500 | Z28 Series

Valve dimensions

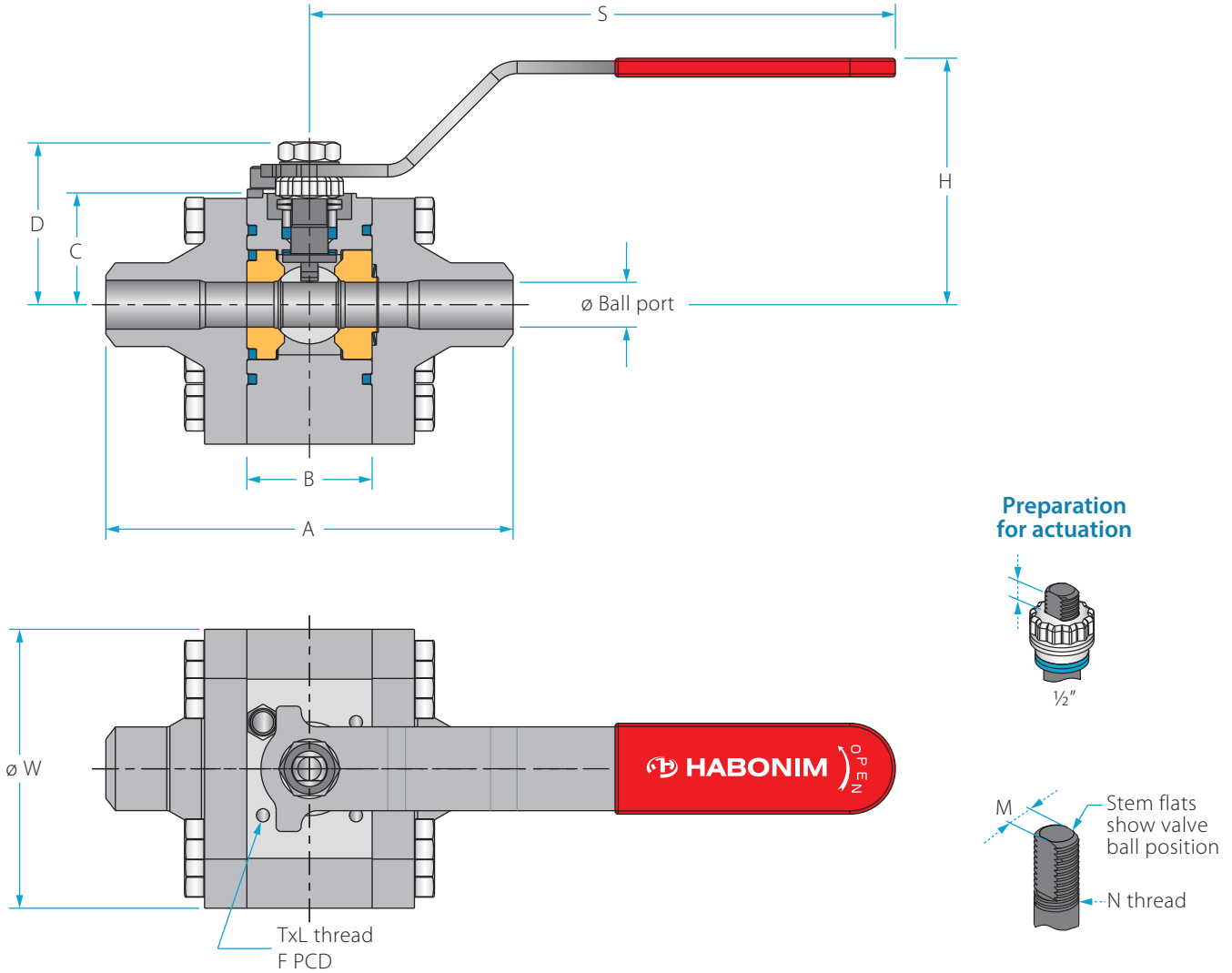

Std. port	Full port	Unit	Ball port	A		B	C	D	H	S	W	M	N	P	F	W	TxL	Weight kg/lb	Kv Cv
				Welded	Threaded														
DN15	DN8, DN10	mm	11.15	159.00	92.00	35.00	29.00	38.00	63.00	150.00	69.00	5.54	3/8"	6.70	(F03)	36.00	M5X10	2.75	6.9
1/2"	1/4", 3/8"	inch	0.44	6.26	3.62	1.38	1.14	1.50	2.48	5.91	2.72	0.22	UNF	0.26		1.42	M5X10	6.1	8.0
DN20	DN15	mm	13.00	169.00	100.00	40.00	34.10	52.40	78.00	230.00	89.00	7.54	7/16"	11.30	(F04)	42.00	M5X10	4.3	10
3/4"	1/2"	inch	0.51	6.65	3.94	1.57	1.34	2.06	3.07	9.06	3.50	0.30	UNF	0.44		1.65	M5X10	9.5	12
DN25	DN20	mm	20.65	190.00	125.00	49.00	43.70	66.00	92.00	237.00	104.00	7.54	7/16"	14.30	(F04)	42.00	M5X10	6.8	28
1"	3/4"	inch	0.81	7.48	4.92	1.93	1.72	2.60	3.62	9.33	4.09	0.30	UNF	0.56		1.65	M5X10	15.0	32
DN32	DN25	mm	193.00	187.00	133.00	49.00	51.50	69.50	96.00	237.00	119.00	8.71	9/16"	14.30	(F05)	50.00	M6X12	9.5	49
1 1/4"	1"	inch	7.60	7.36	5.24	1.93	2.03	2.74	3.78	9.33	4.69	0.34	UNF	0.56		1.97	M6X12	20.9	57

Components & materials

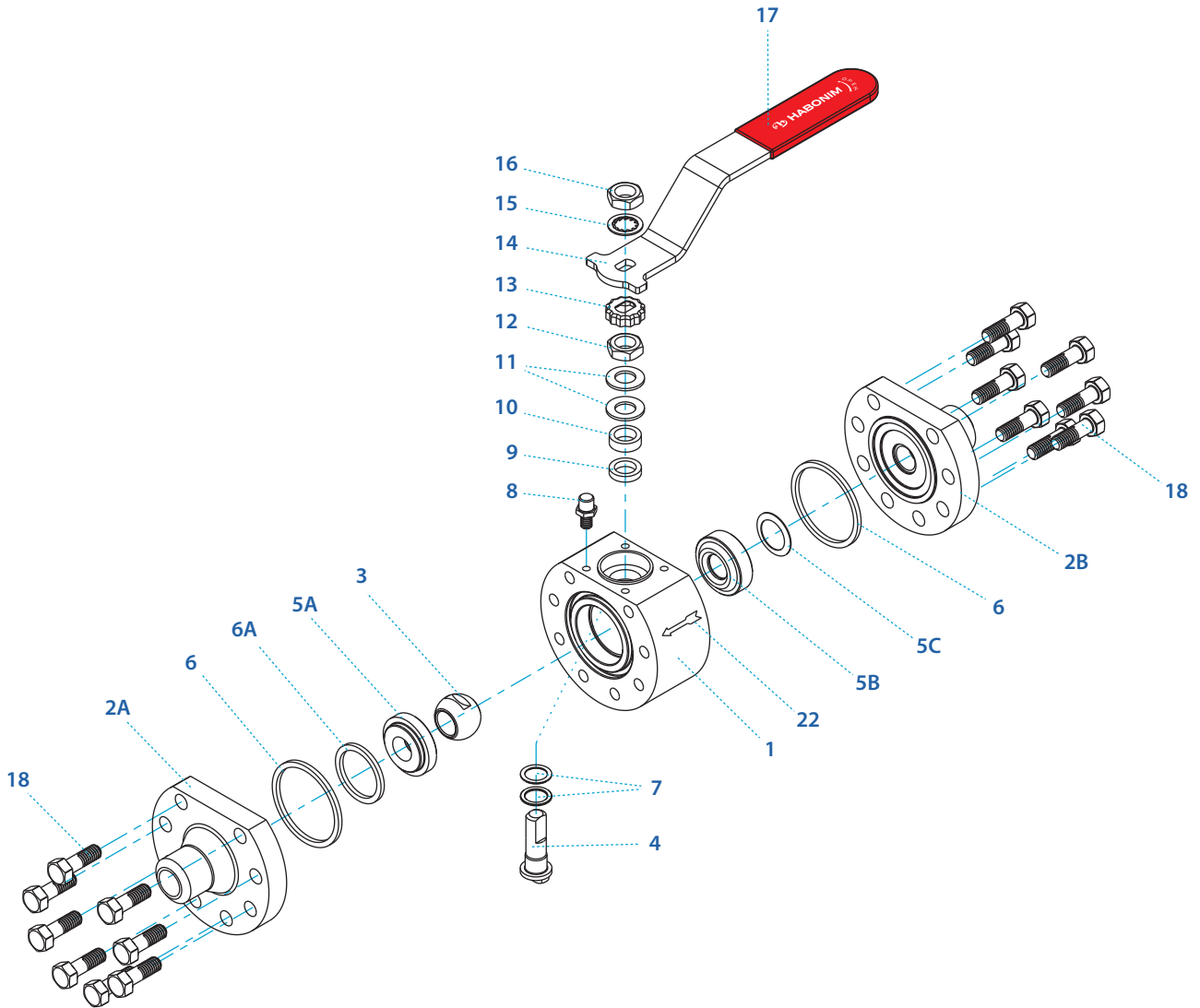

Item	Description	Material specification	Qty.
1	Body	A105, A350 LF2, A479 316L, A479 S31254, A479 S31803, A479 S32750	1
2A	Downstream end	A105, A350 LF2, A479 316L, A479 S31254, A479 S31803, A479 S32750	1
2B	Upstream end	A105, A350 LF2, A479 316L, A479 S31254, A479 S31803, A479 S32750	1
3	Ball	A351 CF8M, A351 CK3MCuN, A995 CD3MN 4A, A995 CE3MN 5A. Hardened with LTPN - Low Temperature Plasma carboNitridding technology	1
4	Stem	A564 Gr.630 H1150D 17-4PH, B637 N07718 Inconel 718	1
5A	Downstream seat	A479 316L, A479 S31254, A479 S31803, A479 S32750. Hardened with LTPN - Low Temperature Plasma carboNitridding technology	1
5B	Upstream seat	A479 316L, A479 S31254, A479 S31803, A479 S32750. Hardened with LTPN - Low Temperature Plasma carboNitridding technology	1
6*	Body seal	Graphite	2
6A	Seat seal	Graphite	1

Item	Description	Material specification	Qty.
7*	Stem thrust seal	A479 316L Hardened with LTPN - Low Temperature Plasma carboNitridding technology, B637 N07718 Inconel 718	2
8	Stop pin	A582 303	1
9*	Stem seal	Graphite	1
10	Follower	B783 316L	1
11	Disc spring	A693 631 17-7PH	2
12	Stem nut	A194 8M, EN3506-2 A4-80	1
13	Locking clip	A167 304	1
14	Handle	A659 G10200 Zinc plate, A240 430	1
15	Serrated washer	A240 410	1
16	Handle nut	A194 8M, EN3506-2 A4-80	1
17	Sleeve	PVC	1
18	Body bolts	EN 3506-1 A4-80, A193 B8M, A193 B7 zinc plated	12-16
22	Arrow flow	A167 304	1
23	Tag (not shown)	A167 304	1

* Repair kit components

Floating Ball Valves

Metal seated valves

General

Up to
400 °C / 752 °F

Up to
538 °C / 1000 °F

Up to
650 °C / 1200 °F

Ordering
code system

Size 1½" - 6" | DN40-DN150 | Class 2500 | Z28 Series

Valve dimensions

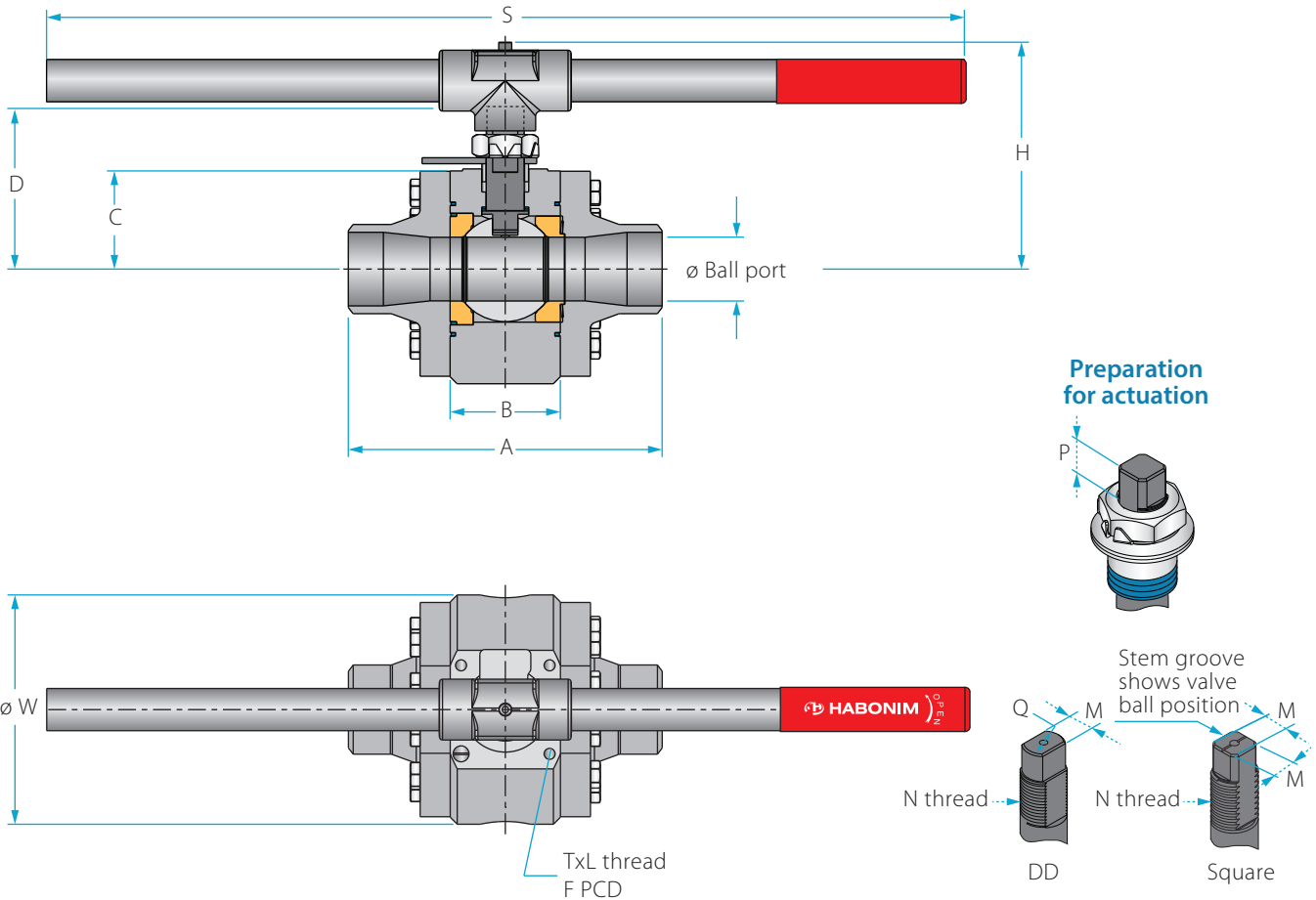

Std. port	Full port	Unit	Ball port	A		B	C	D	H	S	W	M	M (DD)	Q	N	P	F	TxL	Weight kg/lb	Kv Cv
				Welded	Threaded															
DN40	DN32	mm	31.80	237.00	154.00	70.00	53.00	94.60	123.20	401	134.00	-	13.90	20.00	M20x2.5	14.25 (F07)	70.00	M8x12	14.5	69
1½"	1¼"	inch	1.25	9.33	6.06	2.76	2.09	3.72	4.85	15.79	5.28	-	0.55	0.79	M20x2.5	0.56	2.76	M8x12	31.9	80
DN50	DN32	mm	38.10	241.00	157.00	70.00	64.10	101.60	130.00	600.00	169.00	-	13.90	20.00	M20x2.5	13.80 (F07)	70.00	M8x12	22.0	102
2"	1¼"	inch	1.50	9.49	6.18	2.76	2.52	4.00	5.12	23.62	6.65	-	0.55	0.79	M20x2.5	0.54	2.76	M8x12	48.4	118
DN65	DN50	mm	51	302.00	194.00	94.00	87.50	134.00	174.50	401	197.00	18.90	15.90	22.70	1"-14	20.00 (F10)	102.00	M10x20	36.0	208
2½"	2"	inch	2.01	11.89	7.64	3.70	3.44	5.28	6.87	15.79	7.76	0.74	0.63	0.89	UNF-2A	0.79	4.02	M10x20	79.2	241
DN80	DN65	mm	63.75	378.00	254.00	115.00	110.00	167.60	-	-	249.00	28.45	23.75	35.20	1½"-12	22.25 (F12)	125.00	M12x20	76.0	300
3"	2½"	inch	2.51	14.88	10.00	4.53	4.33	6.60	-	-	9.80	1.12	0.94	1.39	UNF-2A	0.88	4.92	M12x20	167.2	348
DN100	DN80	mm	80	410.00	-	130.00	136.00	203.00	-	-	298.00	35.92	35.92	46.50	2"-8	30.00 (F14)	140.00	M16x20	110.0	615
4"	3"	inch	3.15	16.14	-	5.12	5.35	7.99	-	-	11.73	1.41	1.41	1.83	UN-2A	1.18	5.51	M16x20	242.0	713
DN150	DN100	mm	100	510.00	-	175.00	177.00	281.00	-	-	389.00	45.90	45.90	55.00	2¾"-8	40.00 (F16)	165.00	M20x30	235.0	872
6"	4"	inch	3.94	20.08	-	6.89	6.97	11.06	-	-	15.31	1.81	1.81	2.17	UN-2A	1.57	6.50	M20x30	517.0	1012

^{h)} Due to high valve torque, pipe handle cannot be used. A manual gear or automation means should be used to operate the valve.

Components & materials

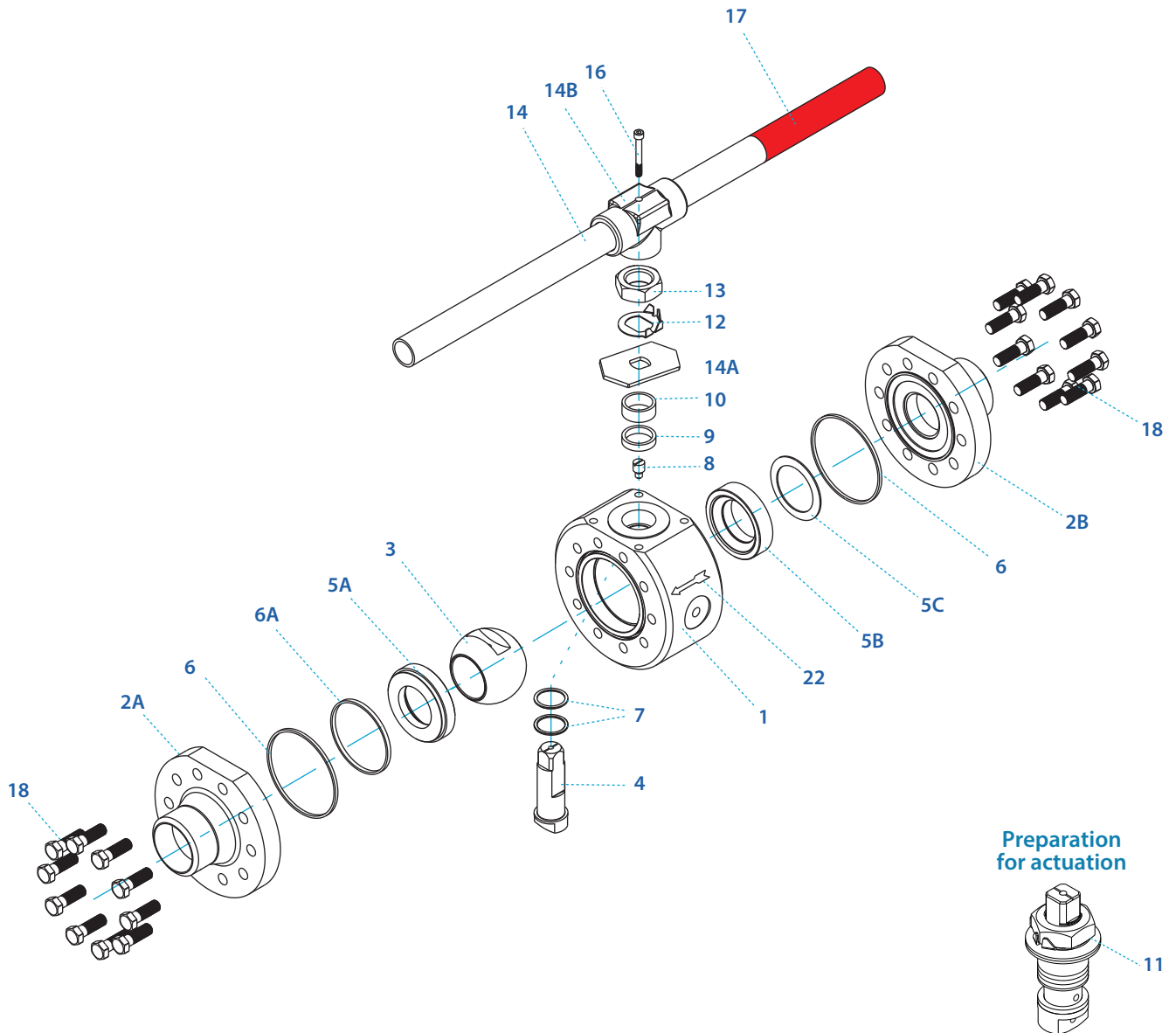

Item	Description	Material specification	Qty.	Item	Description	Material specification	Qty.
1	Body	A105, A350 LF2, A479 316L, A479 S31254, A479 S31803, A479 S32750	1	7*	Stem thrust seal	A479 316L Hardended with LTPN - Low Temperature Plasma carboNitriding technology, B637 N07718 Inconel 718	2
2A	Downstream end	A105, A350 LF2, A479 316L, A479 S31254, A479 S31803, A479 S32750	1	8	Stop pin	A582 303	1
2B	Upstream end	A105, A350 LF2, A479 316L, A479 S31254, A479 S31803, A479 S32750	1	9*	Stem seal	Graphite	1
3	Ball	A351 CF8M, A351 CK3MCuN, A995 CD3MN 4A, A995 CE3MN 5A. Hardended with LTPN - Low Temperature Plasma carboNitriding technology	1	10	Follower	B783 316L	1
4	Stem	A564 Gr.630 H1150D 17-4PH, B637 N07718 Inconel 718	1	11	Disc spring	A693 631 17-7PH	2
5A	Dwონstream seat	A479 316L, A479 S31254, A479 S31803, A479 S32750. Hardended with LTPN - Low Temperature Plasma carboNitriding technology	1	12	Stem nut	A194 8M, EN3506-2 A4-80	1
5B	Upstream end	A479 316L, A479 S31254, A479 S31803, A479 S32750. Hardended with LTPN - Low Temperature Plasma carboNitriding technology	1	13	Tab lock washer	A240 304	1
5C	Upstream seat spring	Inconel 718	1	14**	Handle	C.St. A29 G10200 Zinc plate, A240 430	1
6*	Body seal	Graphite	2	14A	Stop plate	C.St. 1.0402 Zinc plate, A240 430	1
6A	Seat seal	Graphite	1	14B	Wrench head	Ductile Iron A536 Gr. 65-45-12, A216 WCB, A351 CF8M	1
				16	Wrench bolt	EN3506-1 A2-70/A4-80, A193 Gr B8/B8M	1
				17	Sleeve	PVC	1
				18	Body bolts	EN 3506-1 A4-80, A193 B8M, A193 B7 zinc plated	16-52
				22	Arrow flow	A167 304	1
				23	Tag (not shown)	A167 304	1

* Repair kit components

** Gear operator should be used for size 3" DN80 and above (handle components are not included)

Floating Ball Valves

Metal seated valves

General

Up to
400 °C / 752 °F

Up to 538 °C /
1000 °F

Up to
650 °C / 1200 °F

Ordering
code system

Size ¼"- 2" | DN8-DN50 | Class 600 | Z47T Series

Valve dimensions

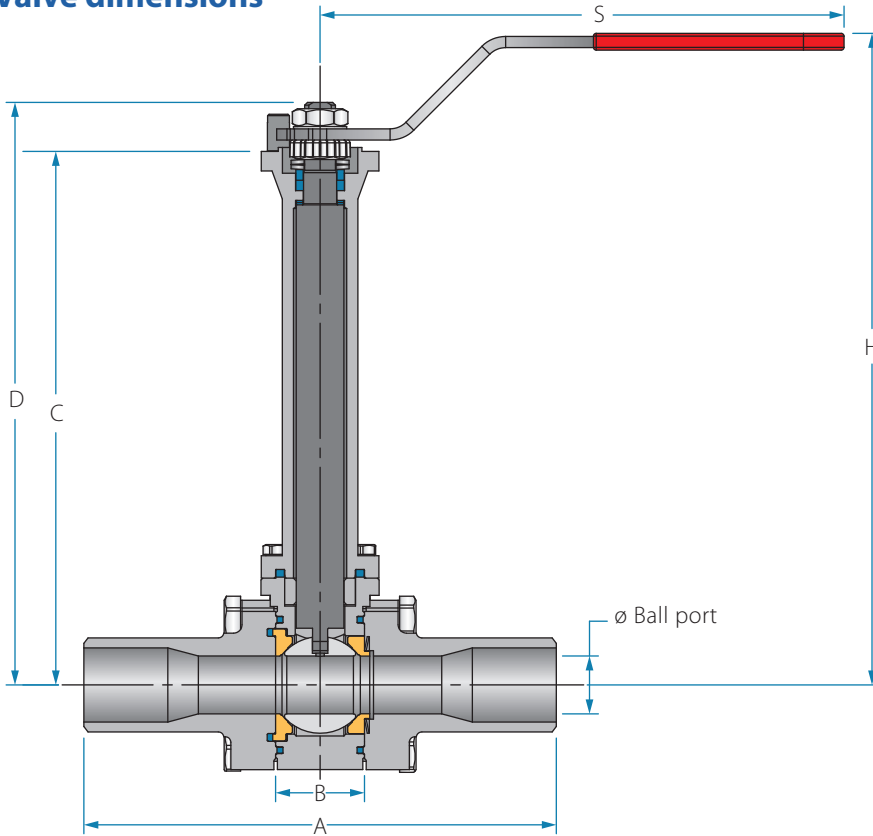

Preparation for actuation

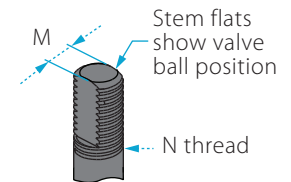
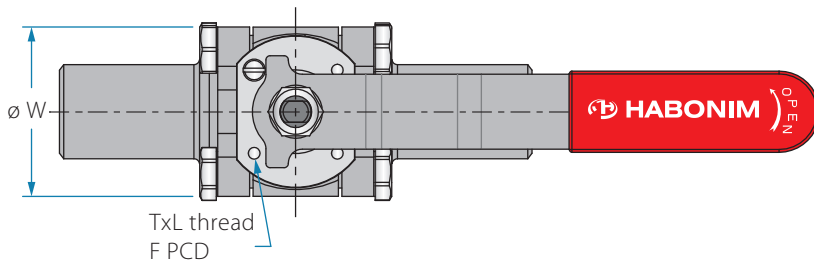
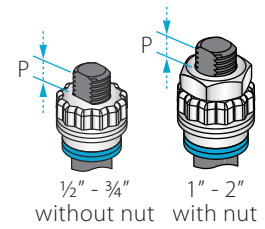

Std. port	Full port	Unit	Ball port	A		B	C	D	H	S	W	M	N	P	F	W	TxL	Weight kg/lb	Kv Cv
				Welded	Threaded														
DN15	DN8, DN10	mm	11.15	140.60	66.00	20.60	181.40	190.30	214.40	150.00	46.00	5.54	3/8"	6.65	(F03)	36.00	M5x10	1.35	6.9
1/2"	1/4", 3/8"	inch	0.44	5.54	2.60	0.81	7.14	7.49	8.44	5.91	1.81	0.22	UNF	0.26		1.42	M5x10	2.97	8.0
DN20	DN15	mm	14.30	146.95	70.60	24.55	183.40	192.30	216.40	150.00	52.10	5.54	3/8"	6.65	(F03)	36.00	M5x10	1.55	10
3/4"	1/2"	inch	0.56	5.79	2.78	0.97	7.22	7.57	8.52	5.91	2.05	0.22	UNF	0.26		1.42	M5x10	3.41	12
DN25	DN20	mm	20.65	168.75	94.00	31.75	190.40	207.90	231.40	230.00	60.50	7.54	7/16"	7.40	(F04)	42.00	M5x10	2.85	28
1"	3/4"	inch	0.81	6.64	3.70	1.25	7.50	8.19	9.11	9.06	2.38	0.30	UNF	0.29		1.65	M5x10	6.27	32
DN32	DN25	mm	25.50	179.25	108.50	41.25	195.40	212.90	236.40	230.00	69.00	7.54	7/16"	7.40	(F04)	42.00	M5x10	3.55	49
1 1/4"	1"	inch	1.00	7.06	4.27	1.62	7.69	8.38	9.31	9.06	2.72	0.30	UNF	0.29		1.65	M5x10	7.81	57
DN40	DN32	mm	31.80	189.40	116.00	48.40	195.40	224.90	248.40	237.00	79.20	8.71	9/16"	8.50	(F05)	50.00	M6x12	4.50	69
1 1/2"	1 1/4"	inch	1.25	7.46	4.57	1.91	7.69	8.85	9.78	9.33	3.12	0.34	UNF	0.33		1.97	M6x12	9.90	80
DN50	DN40	mm	38.10	200.30	128.00	56.30	200.40	229.90	253.40	237.00	90.70	8.71	9/16"	8.50	(F05)	50.00	M6x12	6.00	102
2"	1 1/2"	inch	1.50	7.89	5.04	2.22	7.89	9.05	9.98	9.33	3.57	0.34	UNF	0.33		1.97	M6x12	13.20	118

Components & materials

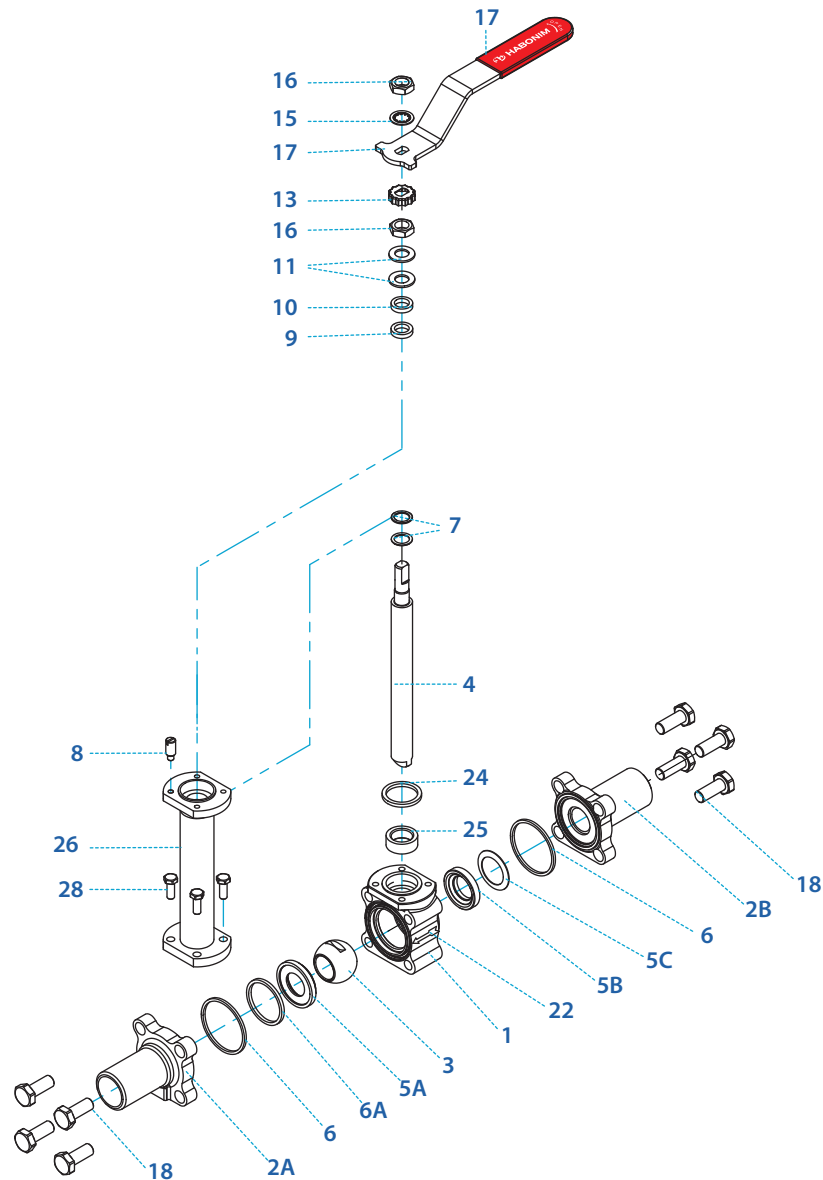

Item	Description	Material specification	Qty.
1	Body	A351 CF8M, A216 WCB, A105	1
2A	Downstream end	A351 CF3M, A216 WCB, A105 , A479 321	1
2B	Upstream end	A351 CF3M, A216 WCB, A105 , A479 321	1
3	Ball	Base material: A182 F316, A182 F316H, A182 F6A Coating**. Cr3C2 - Chromium Carbide with Nickel Chrome binder (HVOF)	1
4	Stem	B637 N07718 Inconel 718	1
5A	Downstream seat	Base material: A182 F316, A182 F316H, A182 F6A Coating**. Cr3C2 - Chromium Carbide with Nickel Chrome binder (HVOF)	1
5B	Upstream seat	Base material: A182 F316, A182 F316H, A182 F6A Coating**. Cr3C2 - Chromium Carbide with Nickel Chrome binder (HVOF)	1
5C	Upstream seat spring	Inconel 718	1
6*	Body seal	Graphite	2
6A*	Seat seal	Graphite	1
7*	Stem thrust seal	A479 316L, Hardened with LTPN - Low Temperature Plasma carboNitriding technology. B637 N07718 Inconel 718	2
8	Stop pin	A582 303	1

Item	Description	Material specification	Qty.
9*	Stem seal	Graphite	1
10	Follower	B783 316L	1
11	Disc spring	A693 631 17-7PH	2
12	Stem nut	A194 8M, EN3506-2 A4-80	1
13	Locking clip	A167 304	1
14	Handle	A659 G10200 Zinc plate, A240 430	1
15	Serrated washer	A240 410	1
16	Handle nut	A194 8M, EN3506-2 A4-80	1
17	Sleeve	PVC	1
18	Body bolts	A193 B8M, A193 B7 zinc plated, A534 660	8
22	Arrow flow	A167 304	1
23	Tag (not shown)	A167 304	1
24	Bonnet seal	Graphite	1
25	Stem Bearing	B637 N07718 Inconel 718 , Bonze	1
26	Bonnet	A351 CF8M, A479 321, A479 321H	1
28	Bonnet bolts	A193 B8M, A534 660	4

* Repair kit components

** Other coatings available

WC-Co - Tungsten Carbide with Cobalt binder (HVOF), Stellite (PTA)

Floating Ball Valves

Metal seated valves

General

Up to
400 °C / 752 °F

Up to
538 °C / 1000 °F

Up to
650 °C / 1200 °F

Ordering
code system

Size 2½"- 8" | DN65-DN200 | Class 600 | Z47T Series

Valve dimensions

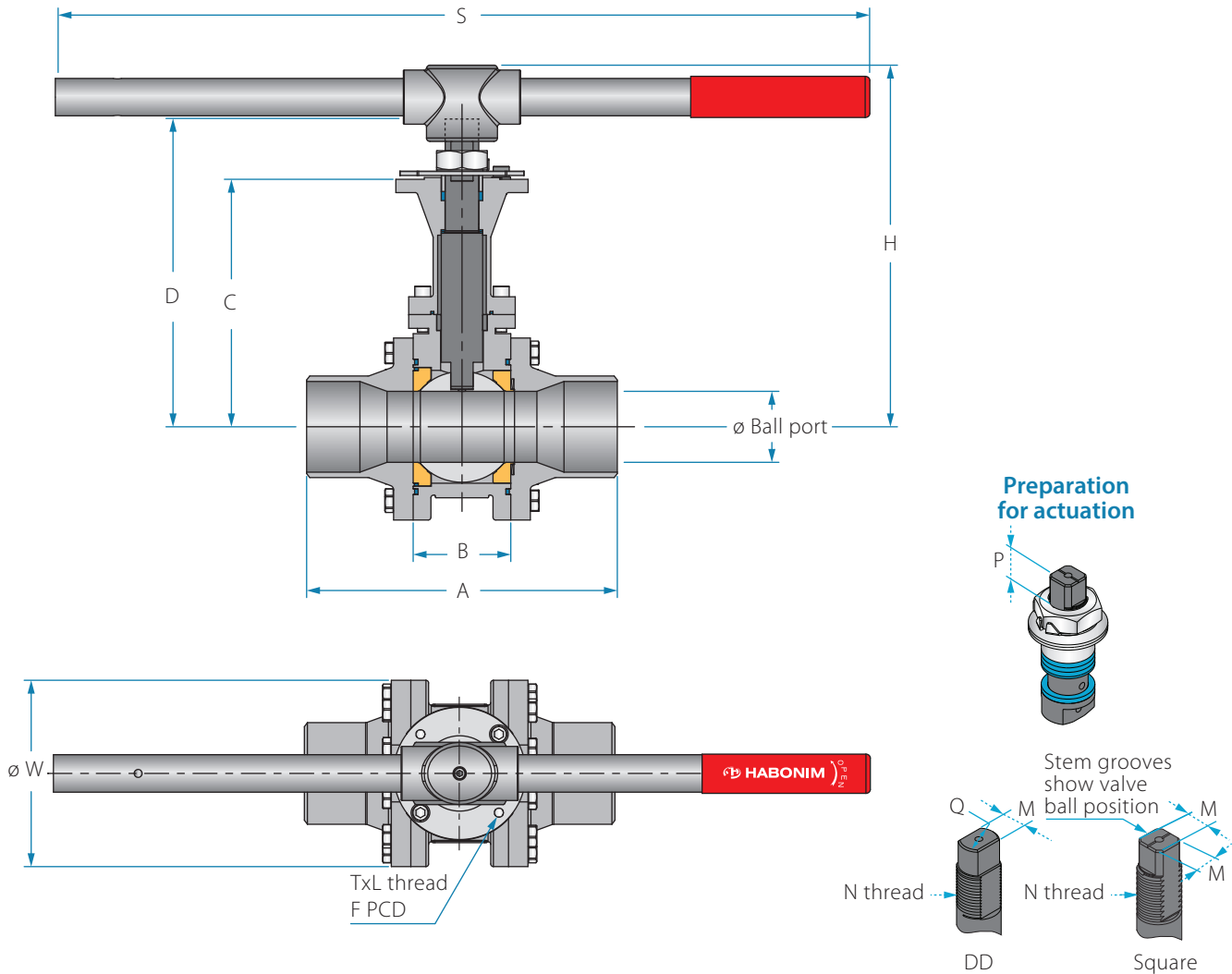

Std. port	Full port	Unit	Ball port	A		B	C	D	H	S	W	M	M (DD)	Q	N	P	F	TxL	Weight kg/lb	Kv Cv
				Welded	Threaded															
DN65	DN50	mm	51	200	160.00	75	239.90	286.40	326.40	401	150	18.90	15.90	22.70	1"-14	16.70 (F10)	102.00	M10x20	19.2	208
2½"	2"	inch	2.01	7.87	6.30	2.95	9.44	11.28	12.85	15.79	5.91	0.74	0.63	0.89	UNS-2A	0.66	4.02	M10x20	42.2	241
DN80	DN65	mm	63.75	285.00	213.00	108.80	266.50	313.00	353.50	600.00	191.50	18.90	15.90	22.70	1"-14	16.70 (F10)	102.00	M10x20	30.0	300
3"	2½"	inch	2.51	11.22	8.39	4.28	10.49	12.32	13.92	23.62	7.54	0.74	0.63	0.89	UNS-2A	0.66	4.02	M10x20	66.0	348
DN100	DN80	mm	80	356	-	110	278.90	348.00	-	-	210	28.45	23.75	35.20	1½"-12	26.20 (F12)	125.00	M12x20	46.0	615
4"	3"	inch	3.15	14.02	-	4.33	10.98	13.70	-	-	8.27	1.12	0.94	1.39	UNF-2A	1.03	4.92	M12x20	101.2	713
DN150	DN100	mm	100	400.00	-	135	294.80	364.00	-	-	260	28.45	23.75	35.20	1½"-12	26.20 (F12)	125.00	M12x20	68.0	872
6"	4"	inch	3.94	15.75	-	5.31	11.61	14.33	-	-	10.24	1.12	0.94	1.39	UNF-2A	1.03	4.92	M12x20	149.6	1012
DN200	DN150	mm	150	490	-	190	397.20	510.00	-	-	360	35.92	35.92	46.50	2"-8	40.00 (F14)	140.00	M16x20	148.0	1552
8"	6"	inch	5.91	19.29	-	7.48	15.64	20.08	-	-	14.17	1.41	1.41	1.83	UN-2A	1.57	5.51	M16x20	325.6	1800
	DN200	mm	200	500	-	275	499.00	654.00	-	-	470	45.90	45.90	55.00	2¾"-8	50.00 (F16)	165.00	M20x30	380.0	1552
	8"	inch	7.87	19.69	-	10.83	19.65	25.75	-	-	18.50	1.81	1.81	2.17	UN-2A	1.97	6.50	M20x30	836.0	1800

^{h)} Due to high valve torque, pipe handle cannot be used. A manual gear or automation means should be used to operate the valve.

Components & materials

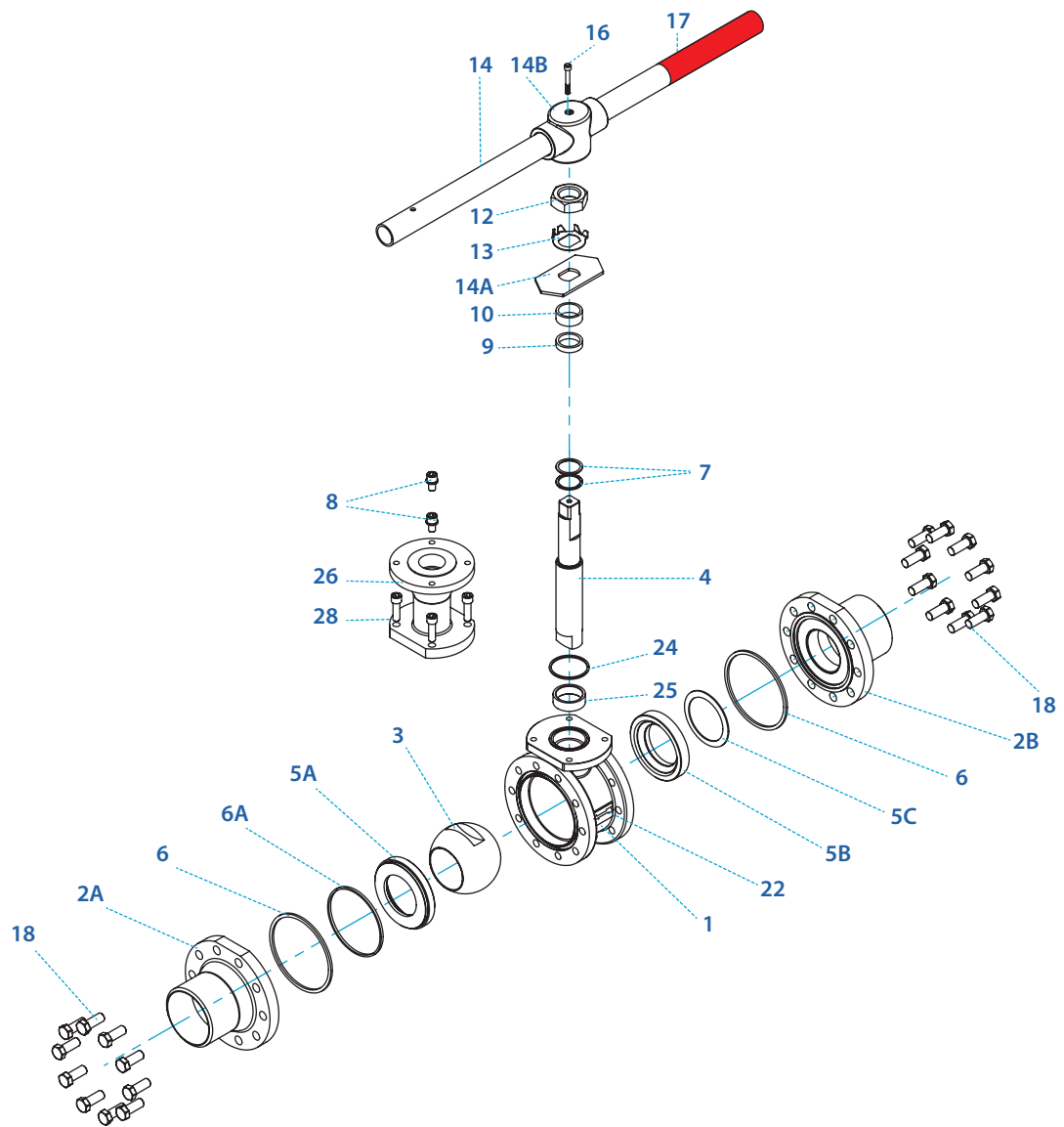

Item	Description	Material specification	Qty.
1	Body	A351 CF8M, A216 WCB	1
2A	Downstream end	A351 CF3M, A216 WCB, A479 321	1
2B	Upstream end	A351 CF3M, A216 WCB, A479 321	1
3	Ball	Base material: A182 F316, A182 F316H, A182 F6A Coating**, Cr3C2 - Chromium Carbide with Nickel Chrome binder (HVOF)	1
4	Stem	B637 N07718 Inconel 718	1
5A	Downstream seat	Base material: A182 F316, A182 F316H, A182 F6A Coating**, Cr3C2 - Chromium Carbide with Nickel Chrome binder (HVOF)	1
5B	Upstream seat	Base material: A182 F316, A182 F316H, A182 F6A Coating**, Cr3C2 - Chromium Carbide with Nickel Chrome binder (HVOF)	1
5C	Upstream seat spring	Inconel 718	1
6*	Body seal	Graphite	2
6B*	Seat seal	Graphite	1
7*	Stem thrust seal	A479 316L, Hardended with LTPN - Low Temperature Plasma carboNitriding technology. B637 N07718 Inconel 718	2
8	Stop pin	A582 303	1

Item	Description	Material specification	Qty.
9*	Stem seal	Graphite	1
10	Follower	B783 316L	1
11	Disc spring	A693 631 17-7PH	2
12	Stem nut	A194 8M, EN3506-2 A4-80	1
13	Tab lock washer	A240 304	1
14***	Handle	C.St. A29 G10200 Zinc plate, A240 430	1
14A	Stop plate	C.St. 1.0402 Zinc plate, A240 430	1
14B	Wrench head	Ductile Iron A536 Gr. 65-45-12, A216 WCB, A351 CF8M	1
16	Wrench bolt	EN3506-1 A2-70/A4-80, A193 Gr B8/B8M	1
17	Sleeve	PVC	1
18	Body bolts	A193 B8M, A193 B7 zinc plated, A534 660	20-32
22	Arrow flow	A167 304	1
23	Tag (not shown)	A167 304	1
24	Bonnet seal	Graphite	1
25	Stem Bearing	B637 N07718 Inconel 718, Bonze	1
26	Bonnet	A351 CF8M, A479 321, A479 316H	1
28	Bonnet bolts	A193 B8M, A534 660	4-6

* Repair kit components

** Other coatings available

*** Gear operator should be used for size 4" DN100 and above (handle components are not included)

Floating Ball Valves

Metal seated valves

General

Up to
400 °C / 752 °F

Up to
538 °C / 1000 °F

Up to
650 °C / 1200 °F

Ordering
code system

Size 1"- 1½" | DN25-DN40 | Class 150/300 | Z73T/Z74T Series

Valve dimensions

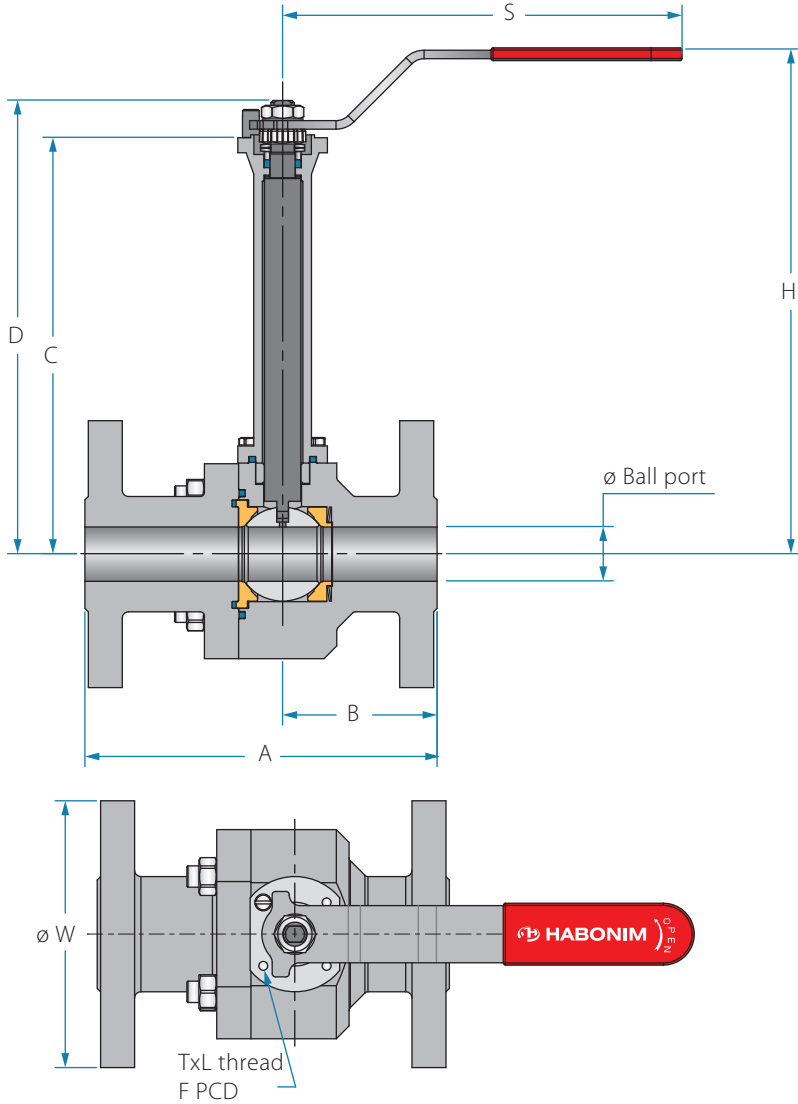

Preparation for actuation

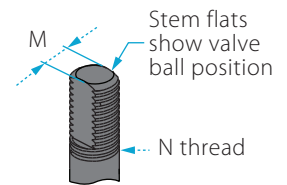
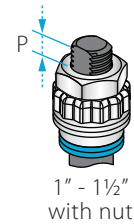

Std. port	Unit	Ball port	A		B		C	D	H	S	W		M	N	P	F	TxL	Weight kg/lb		Kv
			150	300	150	300					150	300						150	300	
DN25	mm	25.40	127.00	165.00	55.00	73.00	195.00	213.00	236.50	230.00	108.00	156.00	7.54	7/16" UNF	7.40 (F04)	42.00	M5x10	6.5	8.0	80
1"	inch	1.00	5.00	6.50	2.17	2.87	7.68	8.39	9.31	9.06	4.25	-	0.30	7/16" UNF	0.29	1.65	M5x10	14.3	17.6	93
DN40	mm	38.10	165.00	190.00	68.00	80.40	201.00	230.60	276.80	237.00	127.00	165.00	8.71	9/16" UNF	8.50 (F05)	50.00	M6x12	8.5	11.5	220
1½"	inch	1.50	6.50	7.48	2.68	3.17	7.91	9.08	10.90	9.33	5.00	-	0.34	9/16" UNF	0.33	1.97	M6x12	18.7	25.3	255

Use Z47T valve series for sizes ½" (DN15) and ¾" (DN20)

Components & materials

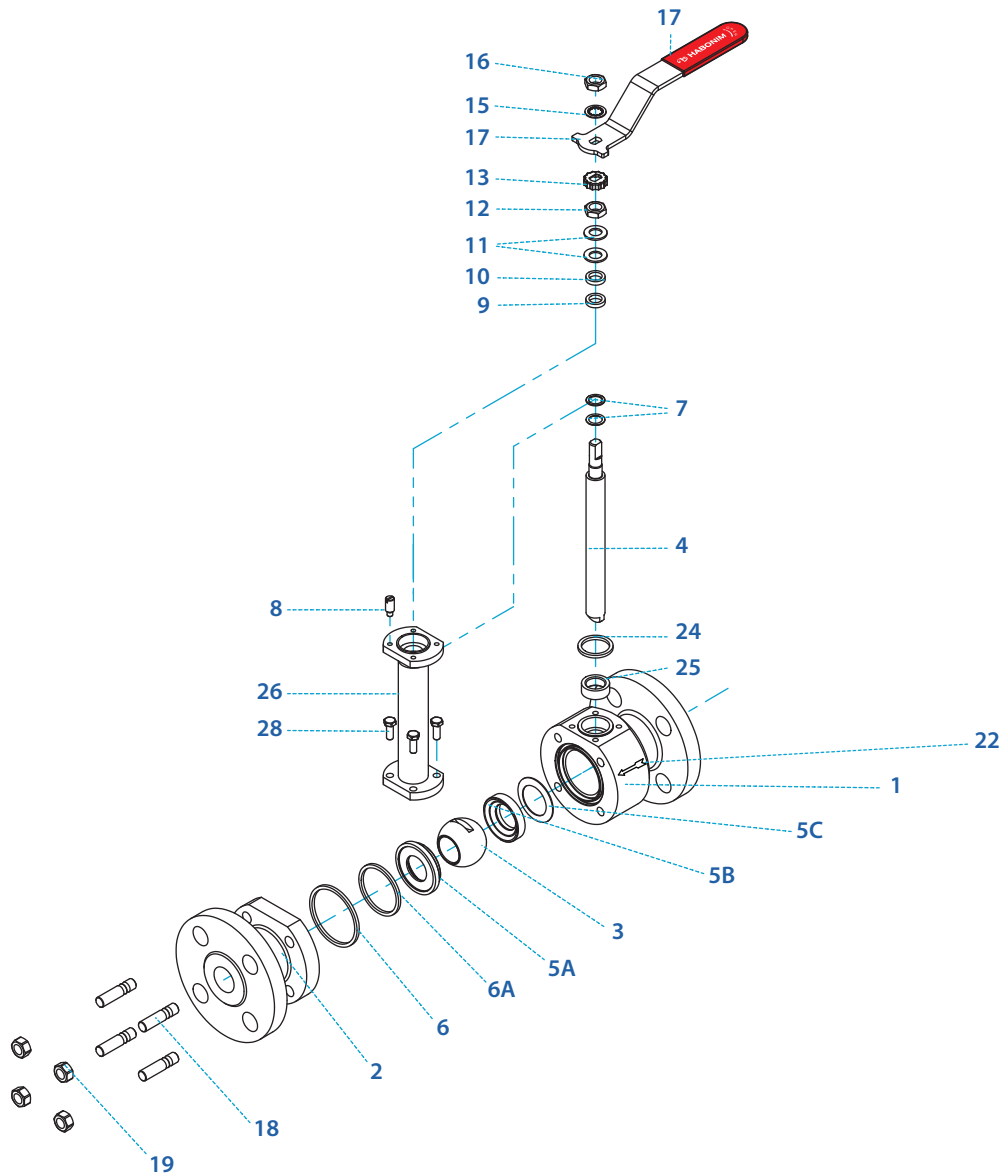

Item	Description	Material specification	Qty.
1	Body	A479, 316L, A479 321, A350 LF2, A351 CF8M, A216 WCB	1
2	end	A479, 316L, A479 321, A350 LF2, A351 CF8M, A216 WCB	1
3	Ball	Base material: A182 F316, A182 F316H, A182 F6A Coating**: Cr3C2 - Chromium Carbide with Nickel Chrome binder (HVOF)	1
4	Stem	B637 N07718 Inconel 718	1
5A	Downstream seat	Base material: A182 F316, A182 F316H, A182 F6A Coating**: Cr3C2 - Chromium Carbide with Nickel Chrome binder (HVOF)	1
5B	Upstream seat	Base material: A182 F316, A182 F316H, A182 F6A Coating**: Cr3C2 - Chromium Carbide with Nickel Chrome binder (HVOF)	1
5C	Upstream seat spring	Inconel 718	1
6*	Body seal	Graphite	2
6A*	Seat seal	Graphite	1
7*	Stem thrust seal	A479 316L, Hardended with LTPN - Low Temperature Plasma carboNitridding technology. B637 N07718 Inconel 718	2

Item	Description	Material specification	Qty.
8	Stop pin	A582 303	1
9*	Stem seal	Graphite	1
10	Follower	B783 316L	1
11	Disc spring	A693 631 17-7PH	2
12	Stem nut	A194 8M, EN3506-2 A4-80	1
13	Locking clip	A167 304	1
14	Handle	A659 G10200 Zinc plate, A240 430	1
15	Serrated washer	A240 410	1
16	Handle nut	A194 8M, EN3506-2 A4-80	1
17	Sleeve	PVC	1
18	Body bolts/studs	A193 B8M, A193 B7 zinc plated, A534 660	4
19	Body nuts	A194 B8, A194 7 zinc plated, A534 660	4
22	Arrow flow	A167 304	1
23	Tag (not shown)	A167 304	1
24	Bonnet seal	Graphite	1
25	Stem Bearing	B637 N07718 Inconel 718 , Bonze	1
26	Bonnet	A351 CF8M, A479 321, A479 316H	1
28	Bonnet bolts	A193 B8M, A534 660	4-6

* Repair kit components

** Other coatings available

WC-Co - Tungsten Carbide with Cobalt binder (HVOF), Stellite (PTA)

Floating Ball Valves

Metal seated valves

General

Up to
400 °C / 752 °F

Up to
538 °C / 1000 °F

Up to
650 °C / 1200 °F

Ordering
code system

Size 2"- 8" | DN50-DN200 | Class 150/300 | Z73T/Z74T Series

Valve dimensions

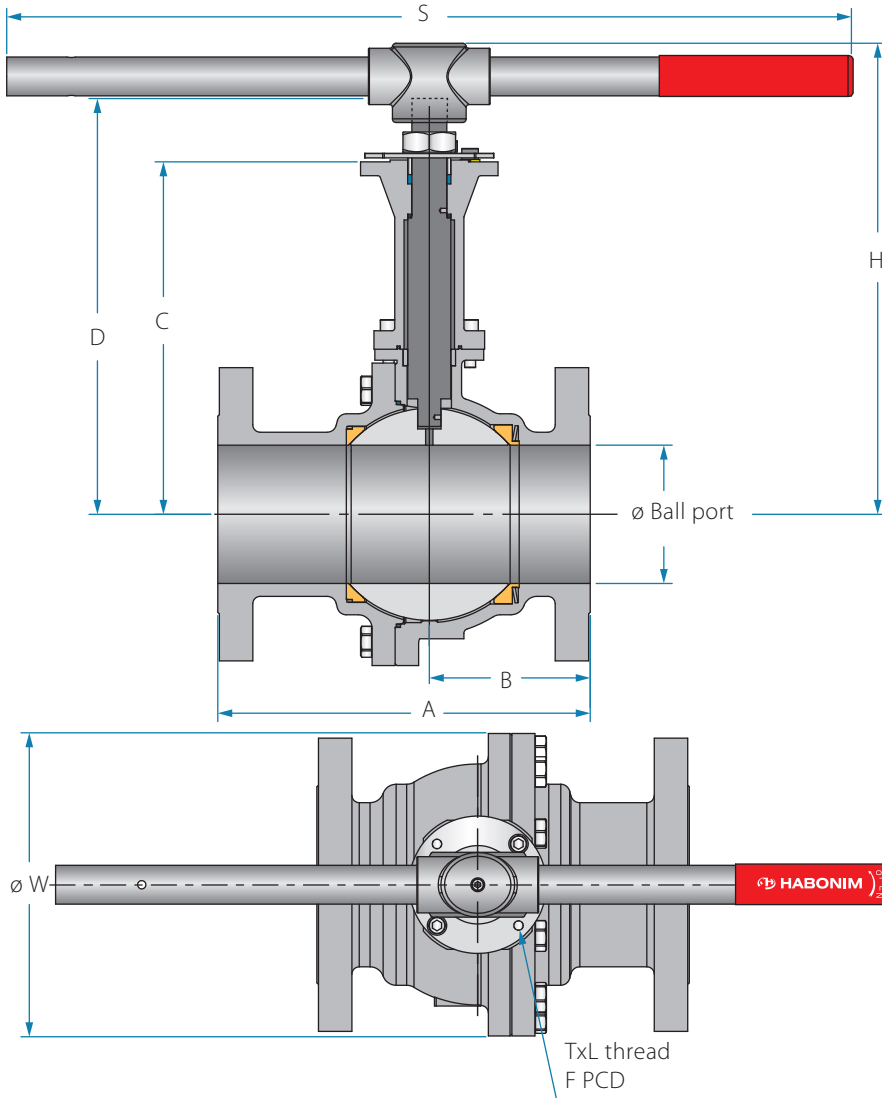

Preparation for actuation

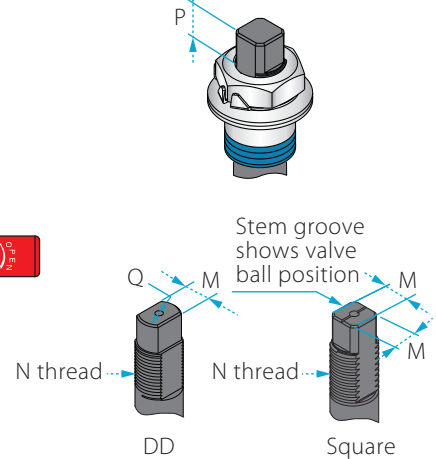

Std. port	Unit	Ball port	A		B		C	D	H	S	W		M	M DD	Q	N	P	F	TxL	Weight kg/lb		Kv
			150	300	150	300					150	300								150	300	
DN50	mm	51	178.00	216.00	69.00	75.10	222.80	264.40	290.00	256.00	127.00	127.00	-	13.90	20.00	M20x2.5	14.60 (F07)	70.00	M8x12	13.5	15.5	430
2"	inch	2.01	7.01	8.50	2.72	2.96	8.77	10.41	11.42	10.08	5.00	5.00	-	0.55	0.79	M20x2.5	0.57	2.76	M8x12	29.7	34.1	499
DN80	mm	80	203.00	282.50	77.50	96.40	260.40	307.00	347.20	401.00	190.50	210.00	18.90	15.90	22.70	1"-14 UNF-2A	16.70 (F10)	102.00	M10x20	25	32	1000
3"	inch	3.15	7.99	11.12	3.05	3.80	10.25	12.09	13.67	15.79	7.50	8.27	0.74	0.63	0.89	1"-14 UNF-2A	0.66	4.02	M10x20	55.0	70.4	1160
DN100	mm	100	228.50	304.80	84.50	104.50	276.40	323.00	-	-	230.00	254.00	18.90	15.90	22.70	1"-14 UNF-2A	16.70 (F10)	102.00	M10x20	45	50.0	1830
4"	inch	3.94	9.00	12.00	3.33	4.11	10.88	12.72	-	-	9.06	10.00	0.74	0.63	0.89	1"-14 UNF-2A	0.66	4.02	M10x20	99.0	110.0	2123
DN150	mm	150	394.00	403.50	163.50	174.50	382.20	451.70	-	-	328.00	328.00	28.45	23.75	35.20	1½"-12 UNF-2A	26.20 (F12)	125.00	M12x20	90	110	4380
6"	inch	5.91	15.51	15.89	6.44	6.87	15.05	17.78	-	-	12.91	12.91	1.12	0.94	1.39	1½"-12 UNF-2A	1.03	4.92	M12x20	198.0	242.0	5081
DN200	mm	200	457.20	501.65	242.50	240.70	495.50	608.20	-	-	343.00	381.00	35.92	35.92	46.50	2"-8 UN-2A	37.50 (F14)	140.00	M16x30	210	245	8070
8"	inch	7.87	18.00	19.75	9.55	9.48	19.51	23.94	-	-	13.50	15.00	1.41	1.41	1.83	2"-8 UN-2A	1.48	5.51	M16x30	462.0	539.0	9361

⁶⁾ Due to high valve torque, pipe handle cannot be used. A manual gear or automation means should be used to operate the valve.

Components & materials

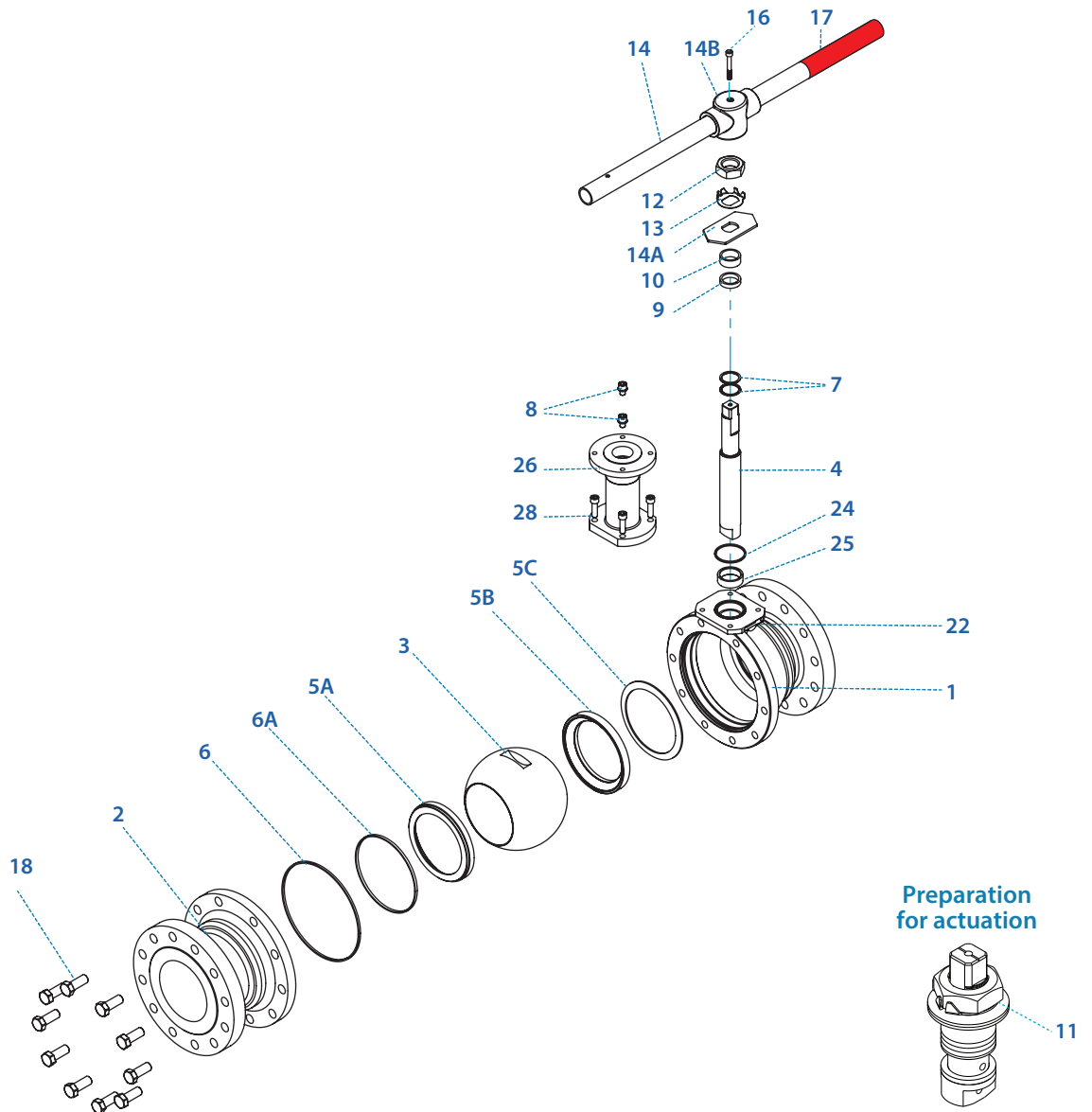

Item	Description	Material specification	Qty.
1	Body	A351 CF8M, A216 WCB	1
2	end	A351 CF8M, A216 WCB	1
3	Ball	Base material: A182 F316, A182 F316H, A182 F6A Coating**: Cr3C2 - Chromium Carbide with Nickel Chrome binder (HVOF)	1
4	Stem	B637 N07718 Inconel 718	1
5A	Downstream seat	Base material: A182 F316, A182 F316H, A182 F6A Coating**: Cr3C2 - Chromium Carbide with Nickel Chrome binder (HVOF)	1
5B	Upstream seat	Base material: A182 F316, A182 F316H, A182 F6A Coating**: Cr3C2 - Chromium Carbide with Nickel Chrome binder (HVOF)	1
5C	Upstream seat spring	Inconel 718	1
6*	Body seal	Graphite	2
6A*	Seat seal	Graphite	1
7*	Stem thrust seal	A479 316L, Hardened with LTPN - Low Temperature Plasma carboNitriding technology. B637 N07718 Inconel 718	2
8	Stop pin	A582 303	1

Item	Description	Material specification	Qty.
9*	Stem seal	Graphite	1
10	Follower	B783 316L	1
11	Disc spring	A693 631 17-7PH	2
12	Stem nut	A194 8M, EN3506-2 A4-80	1
13	Tab lock washer	A240 304	1
14***	Handle	C.St. A29 G10200 Zinc plate, A240 430	1
14A	Stop plate	C.St. 1.0402 Zinc plate, A240 430	1
14B	Wrench head	Ductile Iron A536 Gr. 65-45-12, A216 WCB, A351 CF8M	1
16	Wrench bolt	EN3506-1 A2-70/A4-80, A193 Gr B8/B8M	1
17	Sleeve	PVC	1
18	Body bolts	A193 B8M, A193 B7 zinc plated, A534 660	8-12
22	Arrow flow	A167 304	1
23	Tag (not shown)	A167 304	1
24	Bonnet seal	Graphite	1
25	Stem Bearing	B637 N07718 Inconel 718, Bonze	1
26	Bonnet	A351 CF8M, A479 321, A479 316H	1
28	Bonnet bolts	A193 B8M, A534 660	4-6

* Repair kit components
 ** Other coatings available
 *** Gear operator should be used for size 4" DN100 and above (handle components are not included)

Floating Ball Valves

Metal seated valves

General

Up to
400 °C / 752 °F

Up to
538 °C / 1000 °F

Up to
650 °C / 1200 °F

Ordering
code system

Size 1"- 1½" | DN25-DN40 | PN40 | Z78T Series

Valve dimensions

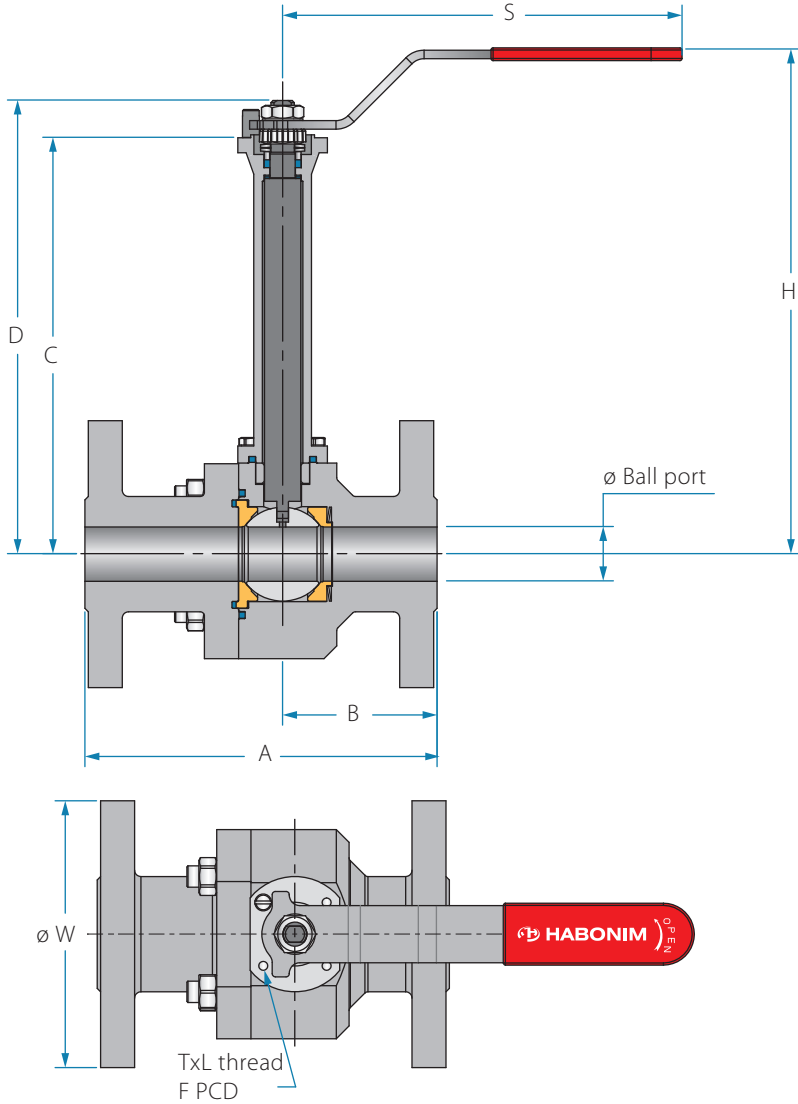

Preparation for actuation

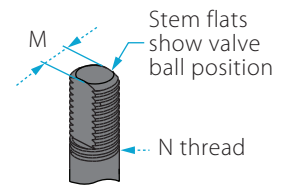
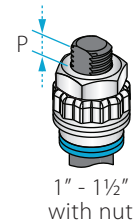

Std. port	Unit	Ball port	A		B	C	D	H	S	W	M	N	P	F	TxL	Weight kg/lb		Kv
			F1	F4												F1	F4	
DN25	mm	25.50	160.00	-	50.50	195.00	213.00	236.50	230.00	115.00	7.54	7/16" UNF	7.40 (F04)	42.00	M5x10	7.0	-	80
1"	inch	1.00	6.30	-	1.99	7.68	8.39	9.31	9.06	4.53	0.30		0.29	1.65		15.4	-	93
DN40	mm	38.10	200.00	140.00	76.00	201.00	230.60	276.80	237.00	150.00	8.71	9/16" UNF	8.50 (F05)	50.00	M6x12	12.0	8.0	220
1½"	inch	1.50	7.87	5.51	2.99	7.91	9.08	10.90	9.33	5.91	0.34		0.33	1.97		26.4	17.6	255

Use Z47T valve series for sizes ½" (DN15) and ¾" (DN20)

Components & materials

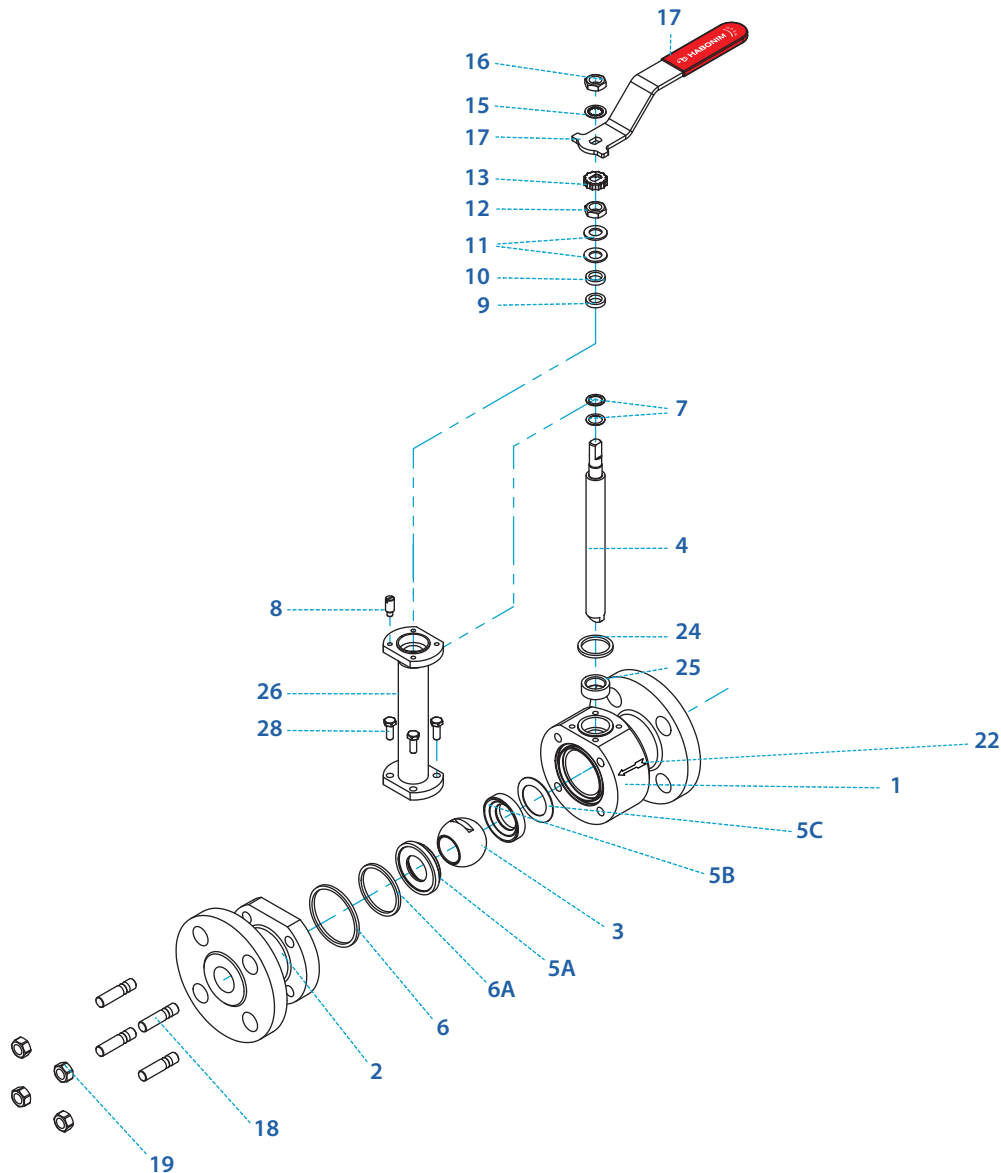

Item	Description	Material specification	Qty.
1	Body	A479, 316L, A479 321, A350 LF2, X2CrNiMo 17 13 2 (1.4404), GS-C25 (DIN1.0619)	1
2	end	A479, 316L, A479 321, A350 LF2, X2CrNiMo 17 13 2 (1.4404), GS-C25 (DIN1.0619)	1
3	Ball	Base material: A182 F316, A182 F316H, A182 F6A Coating**: Cr3C2 - Chromium Carbide with Nickel Chrome binder (HVOF)	1
4	Stem	B637 N07718 Inconel 718	1
5A	Downstream seat	Base material: A182 F316, A182 F316H, A182 F6A Coating**: Cr3C2 - Chromium Carbide with Nickel Chrome binder (HVOF)	1
5B	Upstream seat	Base material: A182 F316, A182 F316H, A182 F6A Coating**: Cr3C2 - Chromium Carbide with Nickel Chrome binder (HVOF)	1
5C	Upstream seat spring	Inconel 718	1
6*	Body seal	Graphite	2
6A*	Seat seal	Graphite	1
7*	Stem thrust seal	A479 316L, Hardended with LTPN - Low Temperature Plasma carboNitridding technology. B637 N07718 Inconel 718	2

Item	Description	Material specification	Qty.
8	Stop pin	A582 303	1
9*	Stem seal	Graphite	1
10	Follower	B783 316L	1
11	Disc spring	A693 631 17-7PH	2
12	Stem nut	A194 8M, EN3506-2 A4-80	1
13	Locking clip	A167 304	1
14	Handle	A659 G10200 Zinc plate, A240 430	1
15	Serrated washer	A240 410	1
16	Handle nut	A194 8M, EN3506-2 A4-80	1
17	Sleeve	PVC	1
18	Body bolts/studs	A193 B8M, A193 B7 zinc plated, A534 660	4
19	Body nuts	A194 B8, A194 7 zinc plated, A534 660	4
22	Arrow flow	A167 304	1
23	Tag (not shown)	A167 304	1
24	Bonnet seal	Graphite	1
25	Stem Bearing	B637 N07718 Inconel 718 , Bonze	1
26	Bonnet	A351 CF8M, A479 321, A479 316H	1
28	Bonnet bolts	A193 B8M, A534 660	4

* Repair kit components

** Other coatings available

WC-Co - Tungsten Carbide with Cobalt binder (HVOF), Stellite (PTA)

Floating Ball Valves

Metal seated valves

General

Up to
400 °C / 752 °F

Up to
538 °C / 1000 °F

Up to
650 °C / 1200 °F

Ordering
code system

Size 2" | DN50 | PN40 | Z78T Series

Size 3"- 6" | DN80-DN150 | PN16 | Z77T Series

Valve dimensions

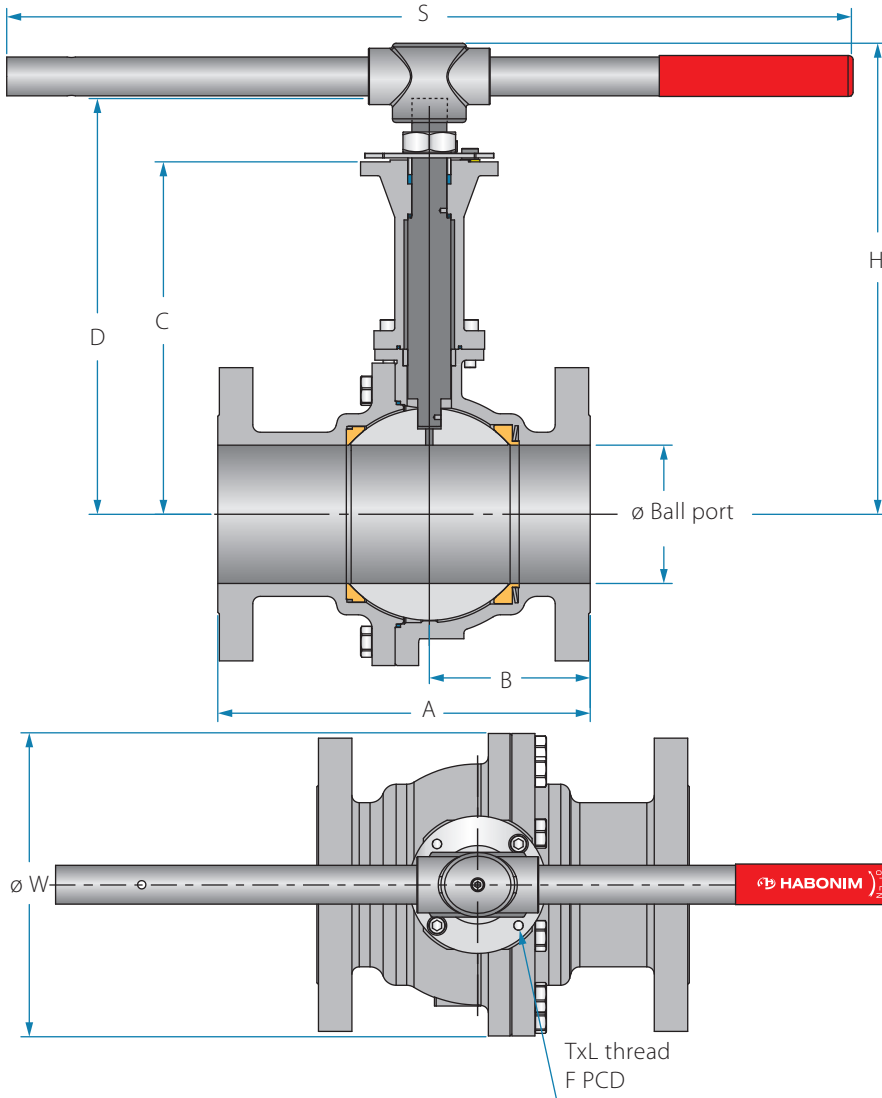

Preparation for actuation

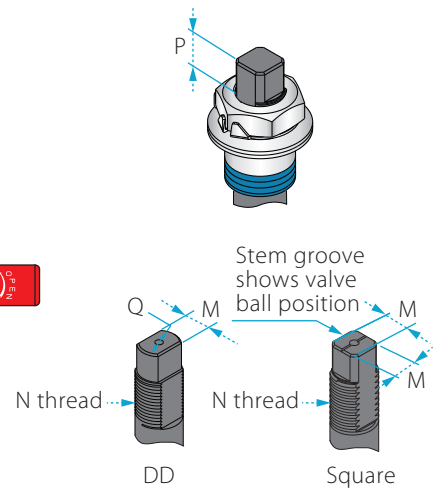

Std. port	Unit	Ball port	A	B	C	D	H	S	W	M	M (DD)	Q	N	P	F	TxL	Weight kg/lb	Cv	
DN50	mm	51	150.00	69.00	222.80	264.40	290.00	256.00	165.00	-	13.90	20.00	M20x2.5	14.60	(F07)	70.00	M8x12	12.5	430
2"	inch	2.01	5.91	2.72	8.77	10.41	11.42	10.08	6.50	-	0.55	0.79		0.57		2.76			27.5
DN80	mm	80	180.00	77.50	260.40	307.00	347.20	401.00	200.00	18.90	15.90	22.70	1"-14 UNF-2A	16.70	(F10)	102.00	M10x20	31.0	1000
3"	inch	3.15	7.09	3.05	10.25	12.09	13.67	15.79	7.87	0.74	0.63	0.89		0.66		4.02			68.2
DN100	mm	100	190.00	84.50	276.40	323.00	-	-	220.00	18.90	15.90	22.70	1"-14 UNF-2A	16.70	(F10)	102.00	M10x20	45.0	1830
4"	inch	3.94	7.48	3.33	10.88	12.72	-	-	8.66	0.74	0.63	0.89		0.66		4.02			99.0
DN150	mm	150	350.00	163.50	382.20	451.70	-	-	285.00	28.45	23.75	35.20	1½"-12 UNF-2A	26.20	(F12)	125.00	M12x20	100.0	4380
6"	inch	5.91	13.78	6.44	15.05	17.78	-	-	11.22	1.12	0.94	1.39		1.03		4.92			220.0

⁶⁾ Due to high valve torque, pipe handle cannot be used. A manual gear or automation means should be used to operate the valve.

Size 2" | DN50 | PN40 | Z78T Series
 Size 3"- 6" | DN80-DN150 | PN16 | Z77T Series

Components & materials

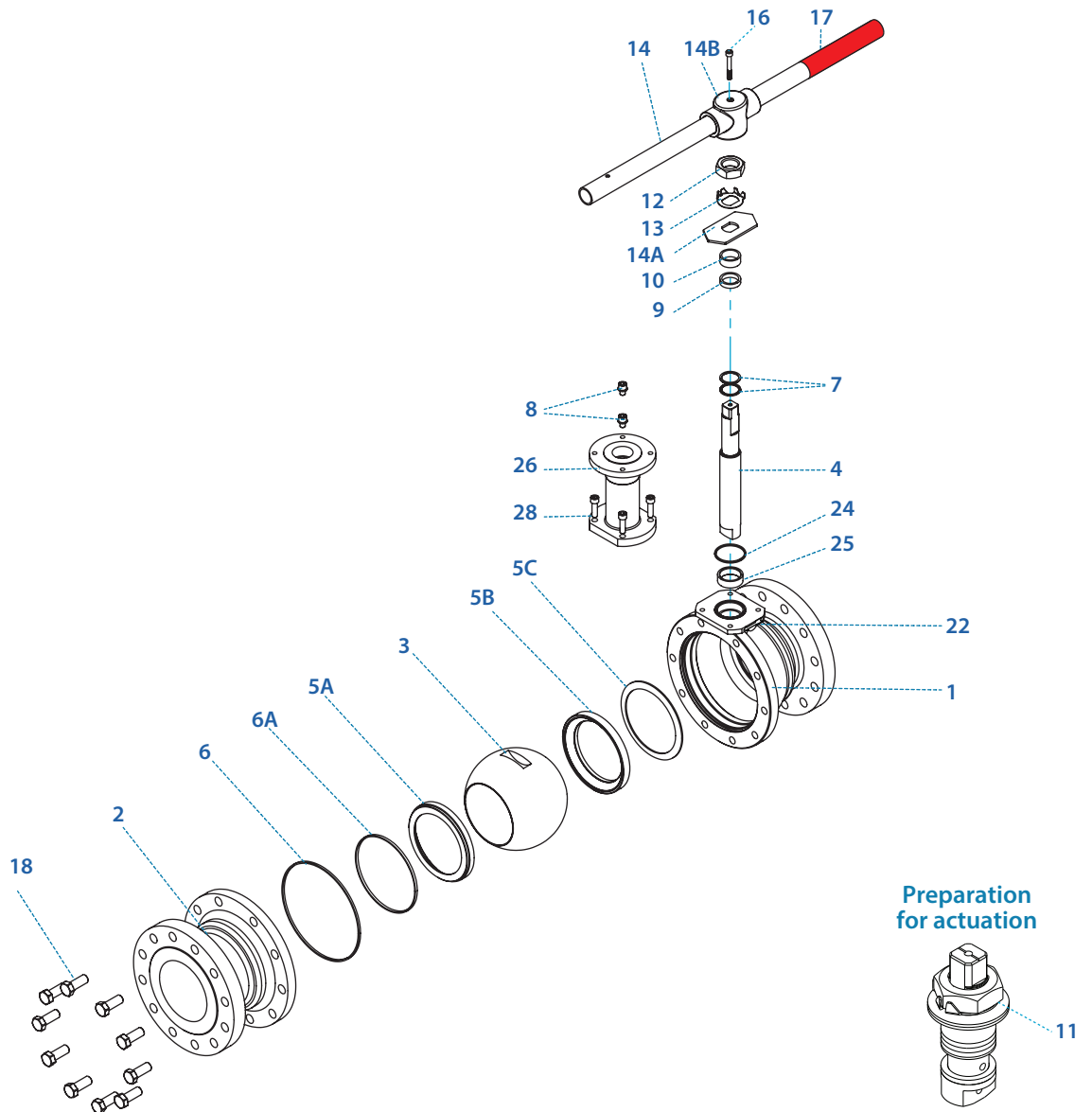

Item	Description	Material specification	Qty.
1	Body	X2CrNiMo 17 13 2 (1.4404), GS-C25 (DIN1.0619), A216 WCB, A351 CF8M	1
2	end	X2CrNiMo 17 13 2 (1.4404), GS-C25 (DIN1.0619), A216 WCB, A351 CF8M	1
3	Ball	Base material: A182 F316, A182 F316H, A182 F6A Coating**: Cr3C2 - Chromium Carbide with Nickel Chrome binder (HVOF)	1
4	Stem	B637 N07718 Inconel 718	1
5A	Downstream seat	Base material: A182 F316, A182 F316H, A182 F6A Coating**: Cr3C2 - Chromium Carbide with Nickel Chrome binder (HVOF)	1
5B	Upstream seat	Base material: A182 F316, A182 F316H, A182 F6A Coating**: Cr3C2 - Chromium Carbide with Nickel Chrome binder (HVOF)	1
5C	Upstream seat spring	Inconel 718	1
6*	Body seal	Graphite	2
6A*	Seat seal	Graphite	1
7*	Stem thrust seal	A479 316L, Hardened with LTPN - Low Temperature Plasma carbonitriding technology. B637 N07718 Inconel 718x	2

Item	Description	Material specification	Qty.
8	Stop pin	A582 303	1
9*	Stem seal	Graphite	1
10	Follower	B783 316L	1
11	Disc spring	A693 631 17-7PH	2
12	Stem nut	A194 8M, EN3506-2 A4-80	1
13	Tab lock washer	A240 304	1
14***	Handle	C.St. A29 G10200 Zinc plate, A240 430	1
14A	Stop plate	C.St. 1.0402 Zinc plate, A240 430	1
14B	Wrench head	Ductile Iron A536 Gr. 65-45-12, A216 WCB, A351 CF8M	1
16	Wrench bolt	EN3506-1 A2-70/A4-80, A193 Gr B8/B8M	1
17	Sleeve	PVC	1
18	Body bolts	A193 B8M, A193 B7 zinc plated, A534 660	8-12
22	Arrow flow	A167 304	1
23	Tag (not shown)	A167 304	1
24	Bonnet seal	Graphite	1
25	Stem Bearing	B637 N07718 Inconel 718 ,Bonze	1
26	Bonnet	A351 CF8M, A479 321, A479 316H	1
28	Bonnet bolts	A193 B8M, A534 660	4-6

* Repair kit components

** Other coatings available

*** Gear operator should be used for size 4" DN100 and above (handle components are not included)

Floating Ball Valves

Metal seated valves

General

Up to
400 °C / 752 °F

Up to
538 °C / 1000 °F

Up to 650 °C /
1200 °F

Ordering
code system

Size 1/4" - 1 1/4" | DN8-DN32 | Class 600 | Z47T Series

Valve dimensions

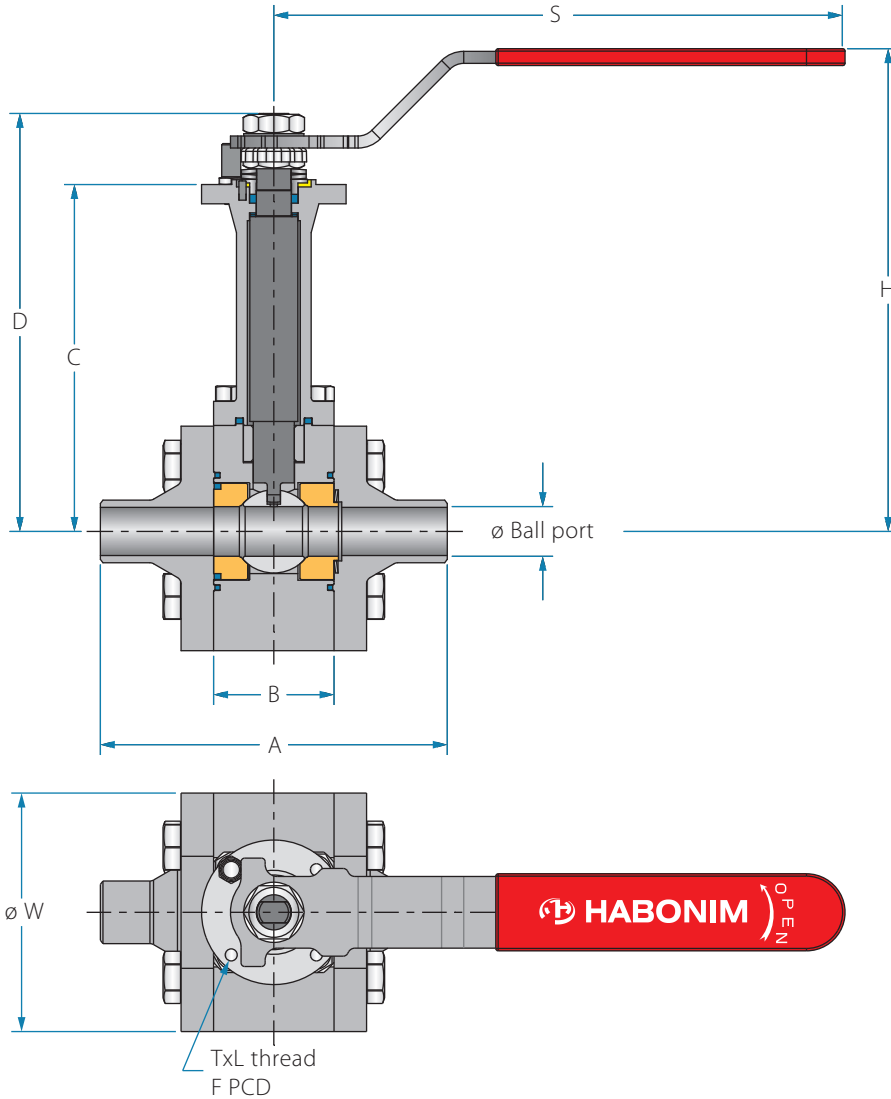

Preparation for actuation

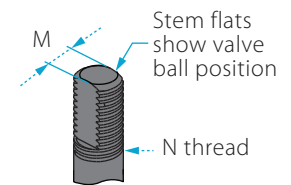
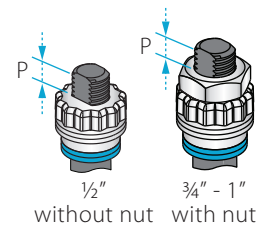

Std. port	Full port	Unit	Ball port	A		B	C	D	H	S	W	M	N	P	F	W	TxL	Weight kg/lb	Kv Cv
				Welded	Threaded														
DN15	DN8, DN10	mm	11.15	159.00	92.00	35.00	182.00	191.00	216.00	150.00	69.50	5.54	3/8"	6.65 (F03)	36.00		M5X10	4.3	6.9
1/2"	1/4", 3/8"	inch	0.44	6.26	3.62	1.38	7.17	7.52	8.50	5.91	2.74	0.22	UNF	0.26	1.42		M5X10	9.5	8.0
DN20	DN15	mm	13.00	169.00	100.00	40.00	187.00	204.50	229.00	230.00	98.00	7.54	7/16"	7.40 (F04)	42.00		M5X10	5.0	10
3/4"	1/2"	inch	0.51	6.65	3.94	1.57	7.36	8.05	9.02	9.06	3.86	0.30	UNF	0.29	1.65		M5X10	11.0	12
DN25	DN20	mm	20.65	190.00	125.00	49.00	196.50	226.00	252.00	237.00	109.00	7.54	7/16"	7.40 (F04)	42.00		M5X10	10.5	28
1"	3/4"	inch	0.81	7.48	4.92	1.93	7.74	8.90	9.92	9.33	4.29	0.30	UNF	0.29	1.65		M5X10	23.1	32
DN32	DN25	mm	193.00	187.00	133.00	49.00	204.50	233.00	260.00	237.00	128.00	8.71	9/16"	8.50 (F05)	50.00		M6X12	13.0	49
1 1/4"	1"	inch	7.60	7.36	5.24	1.93	8.05	9.17	10.24	9.33	5.04	0.34	UNF	0.33	1.97		M6X12	28.6	57

Components & materials

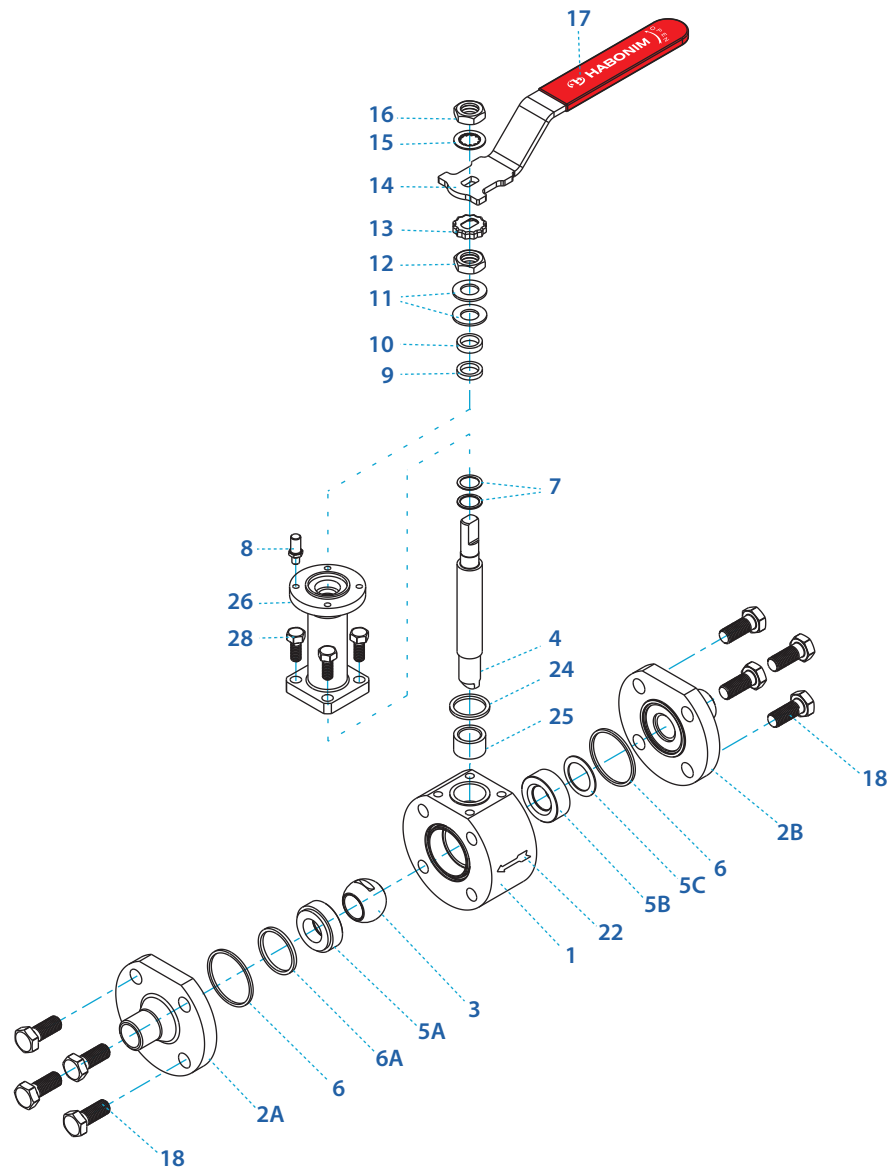

Item	Description	Material specification	Qty.
1	Body	A479 316H, A479 321H, A182 F22, B637 N07718 Inconel 718	1
2A	Downstream end	A479 316H, A479 321H, A182 F22, B637 N07718 Inconel 718	1
2B	Upstream end	A479 316H, A479 321H, A182 F22, B637 N07718 Inconel 718	1
3	Ball	Base material: A182 F316, A182 F316H, A182 F6A Coating: Cr3C2 - Chromium Carbide with Nickel Chrome binder (HVOF).	1
4	Stem	B637 N07718 Inconel 718	1
5A	Downstream seat	Base material: A182 F316, A182 F316H, A182 F6A Coating: Cr3C2 - Chromium Carbide with Nickel Chrome binder (HVOF)	1
5B	Upstream seat	Base material: A182 F316, A182 F316H, A182 F6A Coating: Cr3C2 - Chromium Carbide with Nickel Chrome binder (HVOF)	1
5C	Upstream seat spring	Inconel 718	1
6*	Body seal	Graphite	2
6A*	Seat seal	Graphite	1
7*	Stem thrust seal	A479 316L, Hardended with LTPN - Low Temperature Plasma carboNitriding technology. B637 N07718 Inconel 718	2

Item	Description	Material specification	Qty.
8	Stop pin	A582 303	1
9*	Stem seal	Graphite	1
10	Follower	B783 316L	1
11	Disc spring	A693 631 17-7PH	2
12	Stem nut	A194 8M, EN3506-2 A4-80	1
13	Locking clip	A167 304	1
14	Handle	A659 G10200 Zinc plate, A240 430	1
15	Serrated washer	A240 410	1
16	Handle nut	A194 8M, EN3506-2 A4-80	1
17	Sleeve	PVC	1
18	Body bolts	A193 B8M, A193 B7 zinc plated, A534 660	8
22	Arrow flow	A167 304	1
23	Tag (not shown)	A167 304	1
24	Bonnet seal	Graphite	1
25	Stem Bearing	B637 N07718 Inconel 718 , Bonze	1
26	Bonnet	A479 316H, A479 321H, B637 N07718 Inconel 718	1
28	Bonnet bolts	A193 B8M, A534 660	4

* Repair kit components

Floating Ball Valves

Metal seated valves

General

Up to
400 °C / 752 °F

Up to
538 °C / 1000 °F

Up to
650 °C / 1200 °F

Ordering
code system

Size 1½"- 6" | DN40-DN150 | Class 600 | Z47T Series

Valve dimensions

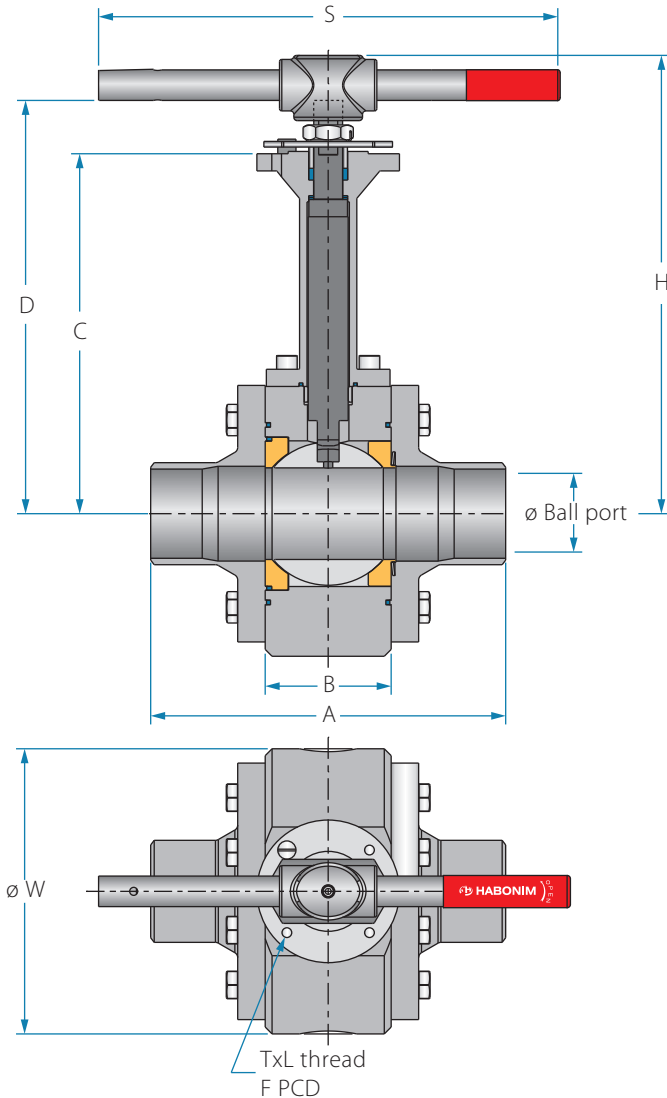

Preparation for actuation

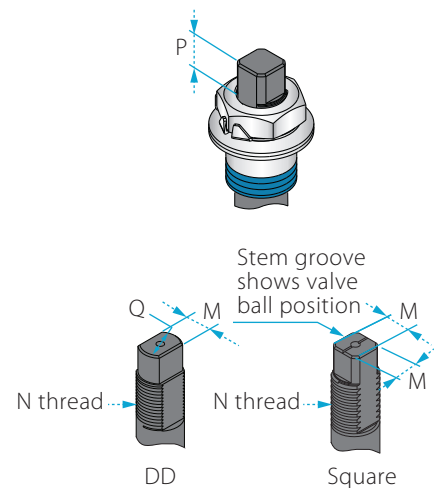

Std. port	Full port	Unit	Ball port	A		B	C	D	H	S	W	M	MDD	Q	N	P	F	W	TxL	Weight kg/lb	Kv Cv
				Welded	Threaded																
DN40	DN32	mm	31.80	237.00	154.00	70.00	205.80	247.40	283.00	401	145.00	-	13.90	20.00	M20x2.5	14.60	(F07)	70.00	M8x12	25	69
1½"	1¼"	inch	1.25	9.33	6.06	2.76	8.10	9.74	11.14	15.79	5.71	-	0.55	0.79	M20x2.5	0.57		2.76	M8x12	55.0	80
DN50	DN40	mm	38.10	241.00	157.00	70.00	257.80	299.40	335.00	600.00	215.00	-	13.90	20.00	M20x2.5	14.60	(F07)	70.00	M8x12	50	102
2"	1½"	inch	1.50	9.49	6.18	2.76	10.15	11.79	13.19	23.62	8.46	-	0.55	0.79	M20x2.5	0.57		2.76	M8x12	110.0	118
DN65	DN50	mm	51	302.00	194.00	94.00	275.00	344.50	384.50	401.00	240.00	18.90	15.90	22.70	1"-14 UNF-2A	16.70	(F10)	102.00	M10x20	80	208
2½"	2"	inch	2.01	11.89	7.64	3.70	10.83	13.56	15.14	15.79	9.45	0.74	0.63	0.89	1"-14 UNF-2A	0.66		4.02	M10x20	176.0	241
DN80	DN65	mm	63.75	378.00	254.00	115.00	292.80	362.30	402.30	600.00	265.00	28.45	23.75	35.20	1½"-12 UNF-2A	26.20	(F12)	125.00	M12x20	125	300
3"	2½"	inch	2.51	14.88	10.00	4.53	11.53	14.26	15.84	23.62	10.43	1.12	0.94	1.39	1½"-12 UNF-2A	1.03		4.92	M12x20	275.0	348
DN100	DN80	mm	80	410.00	-	130.00	395.00	507.70	-	-	310.00	35.92	35.92	46.50	2"-8 UN-2A	40.00	(F14)	140.00	M16x20	175	615
4"	3"	inch	3.15	16.14	-	5.12	15.55	19.99	-	-	12.20	1.41	1.41	1.83	2"-8 UN-2A	1.57		5.51	M16x20	385.0	713
DN150	DN100	mm	100	510.00	-	175.00	480.00	281.00	-	-	395.00	45.90	45.90	55.00	2¾"-8 UN-2A	50.00	(F16)	165.00	M20x30	435	872
6"	4"	inch	3.94	20.08	-	6.89	18.90	11.06	-	-	15.55	1.81	1.81	2.17	2¾"-8 UN-2A	1.97		6.50	M20x30	957.0	1012

⁶⁾ Due to high valve torque, pipe handle cannot be used. A manual gear or automation means should be used to operate the valve.

Components & materials

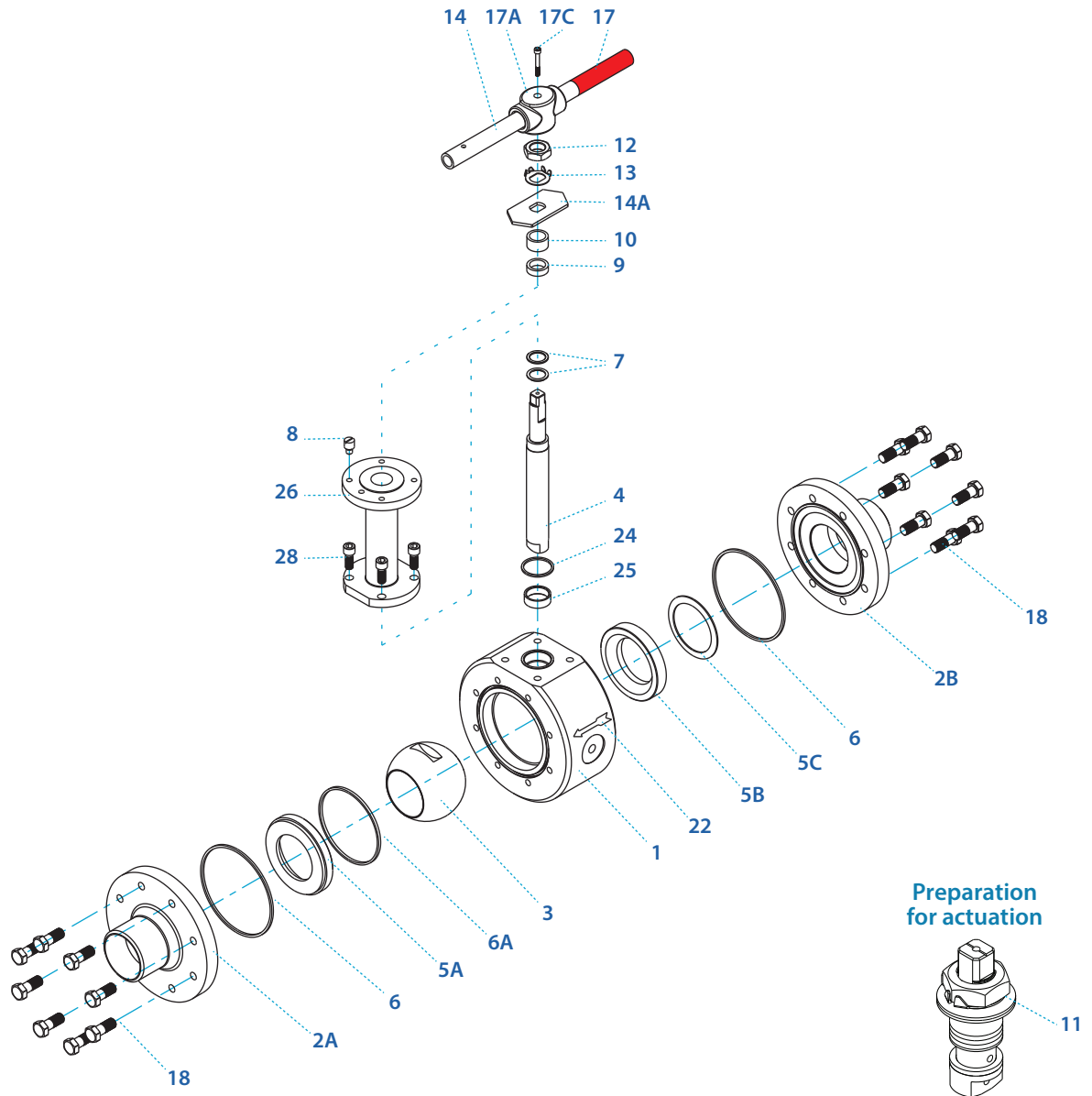

Item	Description	Material specification	Qty.
1	Body	A479 316H, A479 321H, A182 F22, B637 N07718 Inconel 718	1
2A	Downstream end	A479 316H, A479 321H, A182 F22, B637 N07718 Inconel 718	1
2B	Upstream end	A479 316H, A479 321H, A182 F22, B637 N07718 Inconel 718	1
3	Ball	Base material: A182 F316, A182 F316H, A182 F6A Coating: Cr3C2 - Chromium Carbide with Nickel Chrome binder (HVOF)	1
4	Stem	B637 N07718 Inconel 718	1
5A	Downstream seat	Base material: A182 F316, A182 F316H, A182 F6A Coating: Cr3C2 - Chromium Carbide with Nickel Chrome binder (HVOF)	1
5B	Upstream seat	Base material: A182 F316, A182 F316H, A182 F6A Coating: Cr3C2 - Chromium Carbide with Nickel Chrome binder (HVOF)	1
5C	Upstream seat spring	Inconel 718	1
6*	Body seal	Graphite	2
6B*	Seat seal	Graphite	1
7*	Stem thrust seal	A479 316L, Hardened with LTPN - Low Temperature Plasma carboNitrating technology. B637 N07718 Inconel 718	2

Item	Description	Material specification	Qty.
8	Stop pin	A582 303	1
9*	Stem seal	Graphite	1
10	Follower	B783 316L	1
11	Disc spring	A693 631 17-7PH	2
12	Stem nut	A194 8M, EN3506-2 A4-80	1
13	Tab lock washer	A240 304	1
14**	Handle	C.St. A29 G10200 Zinc plate, A240 430	1
14A	Stop plate	C.St. 1.0402 Zinc plate, A240 430	1
14B	Wrench head	Ductile Iron A536 Gr. 65-45-12, A216 WCB, A351 CF8M	1
16	Wrench bolt	EN3506-1 A2-70/A4-80, A193 Gr B8/B8M	1
17	Sleeve	PVC	1
18	Body bolts	A193 B8M, A193 B7 zinc plated, A534 660	20-32
22	Arrow flow	A167 304	1
23	Tag (not shown)	A167 304	1
24	Bonnet seal	Graphite	1
25	Stem Bearing	B637 N07718 Inconel 718, Bonze	1
26	Bonnet	A479 316H, A479 321H, B637 N07718 Inconel 718	1
28	Bonnet bolts	A193 B8M, A534 660	4-6

* Repair kit components

** Gear operator should be used for size 4" DN100 and above (handle components are not included)

Floating Ball Valves

Metal seated valves

General

Up to
400 °C / 752 °F

Up to
538 °C / 1000 °F

Up to
650 °C / 1200 °F

Ordering
code system

Size 1/4" - 1 1/4" | DN8-DN32 | Class 2500 | Z28T Series

Valve dimensions

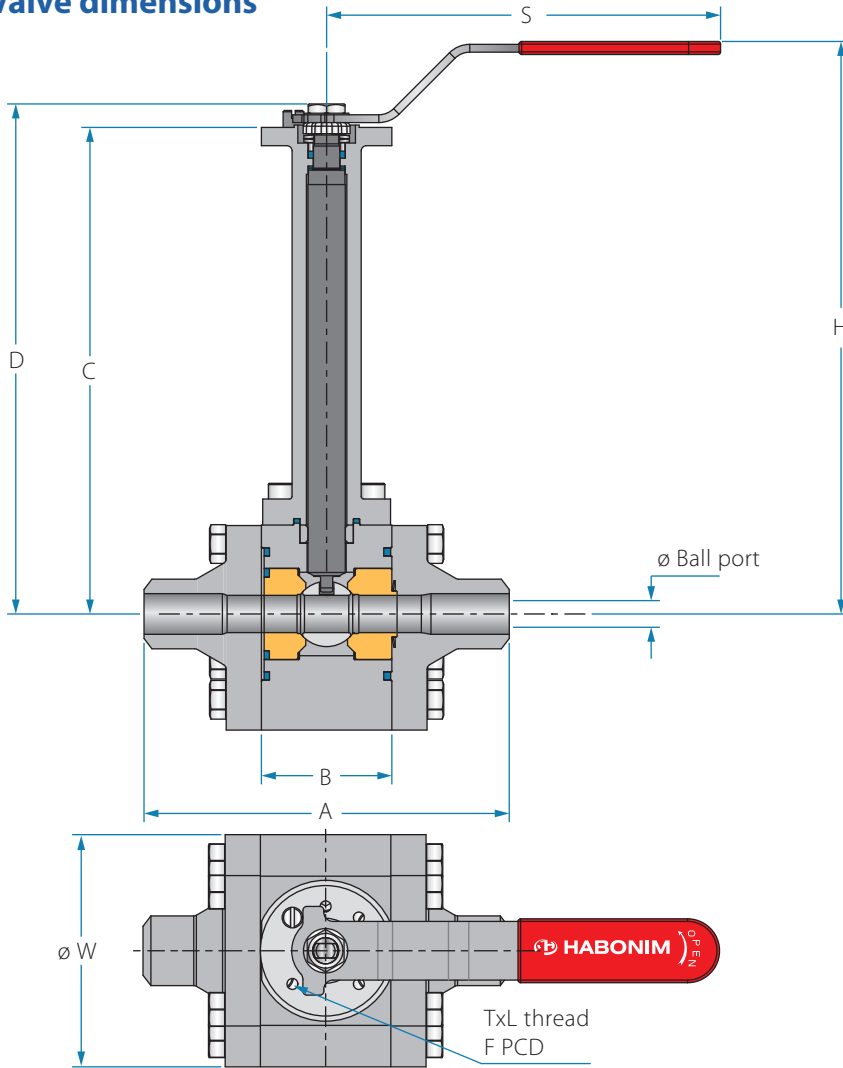

Preparation for actuation

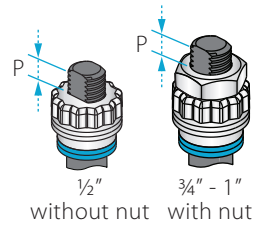

1/2" without nut 3/4" - 1" with nut

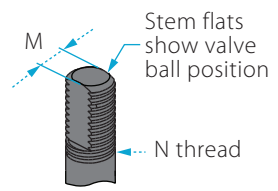

Std. port	Full port	Unit	Ball port	A		B	C	D	H	S	W	M	N	P	F	W	TxL	Weight kg/lb	Kv Cv
				Welded	Threaded														
DN15	DN8, DN10	mm	11.15	174.00	107.00	50.00	182.00	191.00	216.00	150.00	69.50	5.54	3/8"	6.65 (F03)	36.00		M5X10	4.3	6.9
1/2"	1/4", 3/8"	inch	0.44	6.85	4.21	1.97	7.17	7.52	8.50	5.91	2.74	0.22	UNF	0.26	1.42		M5X10	9.5	8.0
DN20	DN15	mm	13.00	189.00	120.00	60.00	187.00	204.50	229.00	230.00	98.00	7.54	7/16"	7.40 (F04)	42.00		M5X10	5.0	10
3/4"	1/2"	inch	0.51	7.44	4.72	2.36	7.36	8.05	9.02	9.06	3.86	0.30	UNF	0.29	1.65		M5X10	11.0	12
DN25	DN20	mm	20.65	209.00	144.00	68.00	196.50	226.00	252.00	237.00	109.00	7.54	7/16"	7.40 (F04)	42.00		M5X10	10.5	28
1"	3/4"	inch	0.81	8.23	5.67	2.68	7.74	8.90	9.92	9.33	4.29	0.30	UNF	0.29	1.65		M5X10	23.1	32
DN32	DN25	mm	193.00	225.00	152.00	68.00	204.50	233.00	260.00	237.00	128.00	8.71	9/16"	8.50 (F05)	50.00		M6X12	13.0	49
1 1/4"	1"	inch	7.60	8.86	5.98	2.68	8.05	9.17	10.24	9.33	5.04	0.34	UNF	0.33	1.97		M6X12	28.6	57

Components & materials

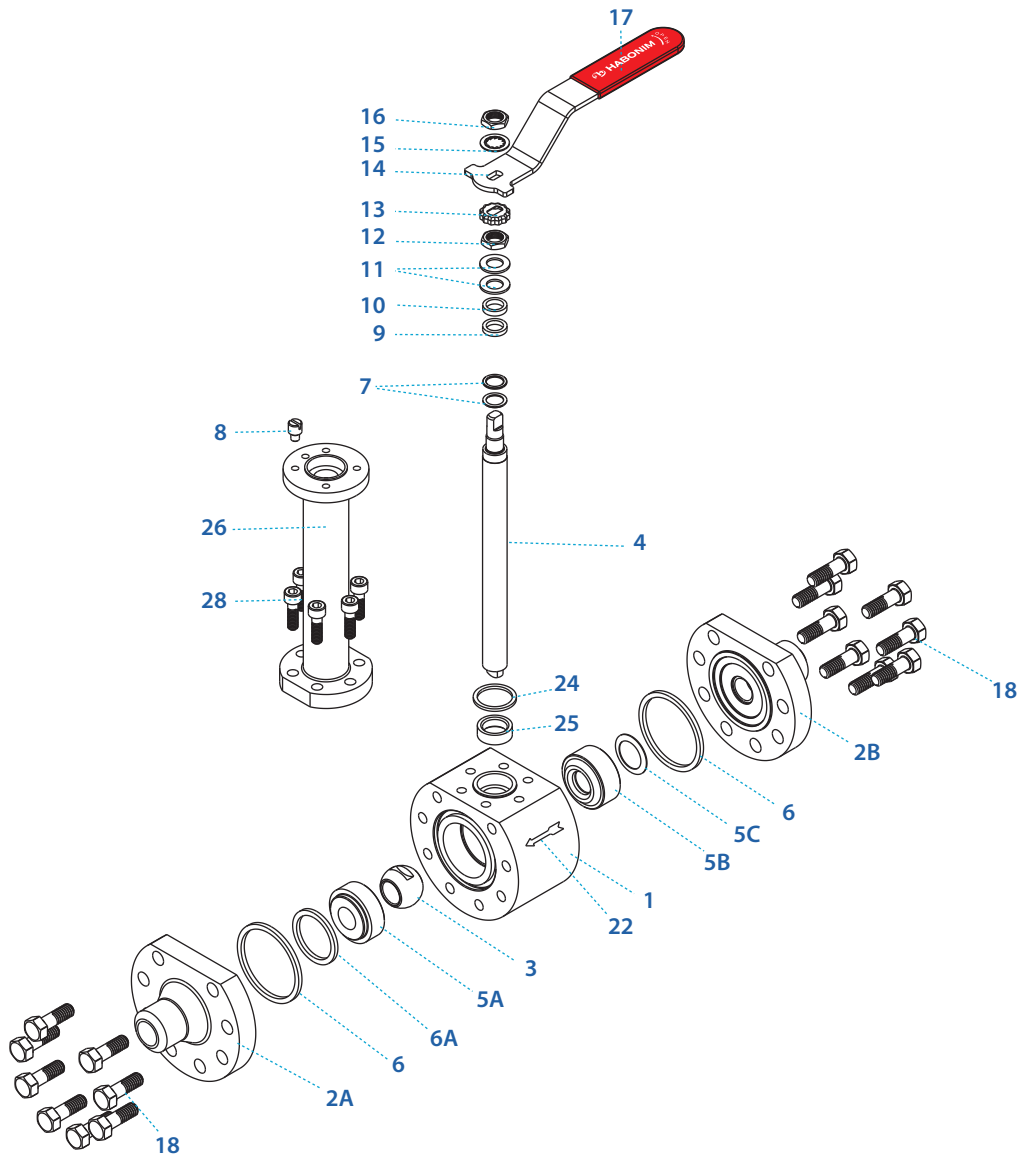

Item	Description	Material specification	Qty.
1	Body	A479 316H, A479 321H, A182 F22, B637 N07718 Inconel 718	1
2A	Downstream end	A479 316H, A479 321H, A182 F22, B637 N07718 Inconel 718	1
2B	Upstream end	A479 316H, A479 321H, A182 F22, B637 N07718 Inconel 718	1
3	Ball	Base material: A182 F316, A182 F316H, A182 F6A Coating: Cr3C2 - Chromium Carbide with Nickel Chrome binder (HVOF)	1
4	Stem	B637 N07718 Inconel 718	1
5A	Downstream seat	Base material: A182 F316, A182 F316H, A182 F6A Coating: Cr3C2 - Chromium Carbide with Nickel Chrome binder (HVOF)	1
5B	Upstream seat	Base material: A182 F316, A182 F316H, A182 F6A Coating: Cr3C2 - Chromium Carbide with Nickel Chrome binder (HVOF)	1
5C	Upstream seat spring	Inconel 718	1
6*	Body seal	Graphite	2
6A*	Seat seal	Graphite	1
7*	Stem thrust seal	A479 316L, Hardended with LTPN - Low Temperature Plasma carboNitriding technology. B637 N07718 Inconel 718	2

Item	Description	Material specification	Qty.
8	Stop pin	A582 303	1
9*	Stem seal	Graphite	1
10	Follower	B783 316L	1
11	Disc spring	A693 631 17-7PH	2
12	Stem nut	A194 8M, EN3506-2 A4-80	1
13	Locking clip	A167 304	1
14	Handle	A659 G10200 Zinc plate, A240 430	1
15	Serrated washer	A240 410	1
16	Handle nut	A194 8M, EN3506-2 A4-80	1
17	Sleeve	PVC	1
18	Body bolts	A193 B8M, A193 B7 zinc plated, A534 660	12-16
22	Arrow flow	A167 304	1
23	Tag (not shown)	A167 304	1
24	Bonnet seal	Graphite	1
25	Stem Bearing	B637 N07718 Inconel 718 , Bonze	1
26	Bonnet	A479 316H, A479 321H, B637 N07718 Inconel 718	1
28	Bonnet bolts	A193 B8M, A534 660	6

* Repair kit components

Floating Ball Valves

Metal seated valves

General

Up to
400 °C / 752 °F

Up to
538 °C / 1000 °F

Up to
650 °C / 1200 °F

Ordering
code system

Size 1½"- 6" | DN40-DN150 | Class 2500 | Z28T Series

Valve dimensions

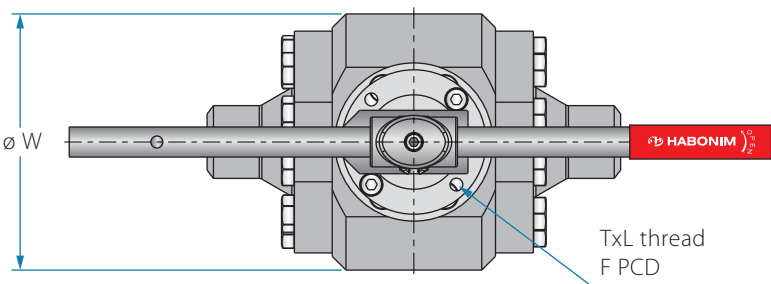
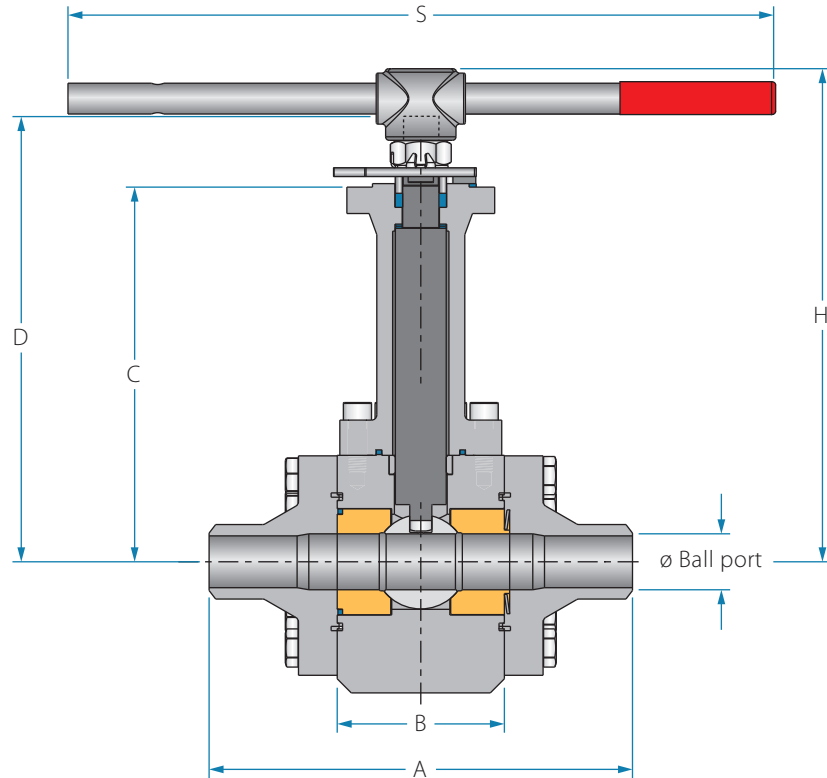

Preparation for actuation

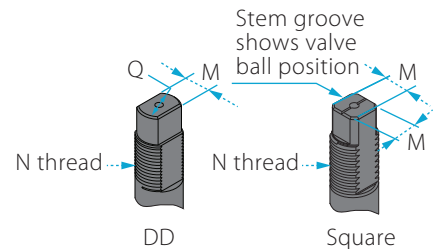
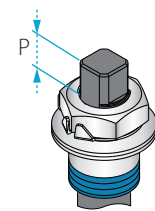

Std. port	Full port	Unit	Ball port	A		B	C	D	H	S	W	M	MDD	Q	N	P	F	W	TxL	Weight kg/lb	Kv Cv
				Welded	Threaded																
DN40	DN32	mm	31.80	237.00	154.00	95.00	205.80	247.40	283.00	401	145.00	-	13.90	20.00	M20x2.5	14.60	(F07)	70.00	M8x12	25	69
1½"	1¼"	inch	1.25	9.33	6.06	3.74	8.10	9.74	11.14	15.79	5.71	-	0.55	0.79		0.57		2.76		55.0	80
DN50	DN40	mm	38.10	241.00	157.00	105.00	257.80	299.40	335.00	600.00	215.00	-	13.90	20.00	M20x2.5	14.60	(F07)	70.00	M8x12	50	102
2"	1½"	inch	1.50	9.49	6.18	4.13	10.15	11.79	13.19	23.62	8.46	-	0.55	0.79		0.57		2.76		110.0	118
DN65	DN50	mm	51	302.00	194.00	125.00	275.00	344.50	384.50	401.00	240.00	18.90	15.90	22.70	1"-14 UNF-2A	16.70	(F10)	102.00	M10x20	80	208
2½"	2"	inch	2.01	11.89	7.64	4.92	10.83	13.56	15.14	15.79	9.45	0.74	0.63	0.89		0.66		4.02		176.0	241
DN80	DN65	mm	63.75	378.00	254.00	140.00	292.80	362.30	-	-	265.00	28.45	23.75	35.20	1½"-12 UNF-2A	26.20	(F12)	125.00	M12x20	125	300
3"	2½"	inch	2.51	14.88	10.00	5.51	11.53	14.26	-	-	10.43	1.12	0.94	1.39		1.03		4.92		275.0	348
DN100	DN80	mm	80	410.00	N/A	140.00	395.00	507.70	-	-	310.00	35.92	35.92	46.50	2"-8 UN-2A	40.00	(F14)	140.00	M16x20	175	615
4"	3"	inch	3.15	16.14	N/A	5.51	15.55	19.99	-	-	12.20	1.41	1.41	1.83		1.57		5.51		385.0	713
DN150	DN100	mm	100	510.00	N/A	195.00	480.00	281.00	-	-	395.00	45.90	45.90	55.00	2¾"-8 UN-2A	50.00	(F16)	165.00	M20x30	435	872
6"	4"	inch	3.94	20.08	N/A	7.68	18.90	11.06	-	-	15.55	1.81	1.81	2.17		1.97		6.50		957.0	1012

⁶⁾ Due to high valve torque, pipe handle cannot be used. A manual gear or automation means should be used to operate the valve.

Components & materials

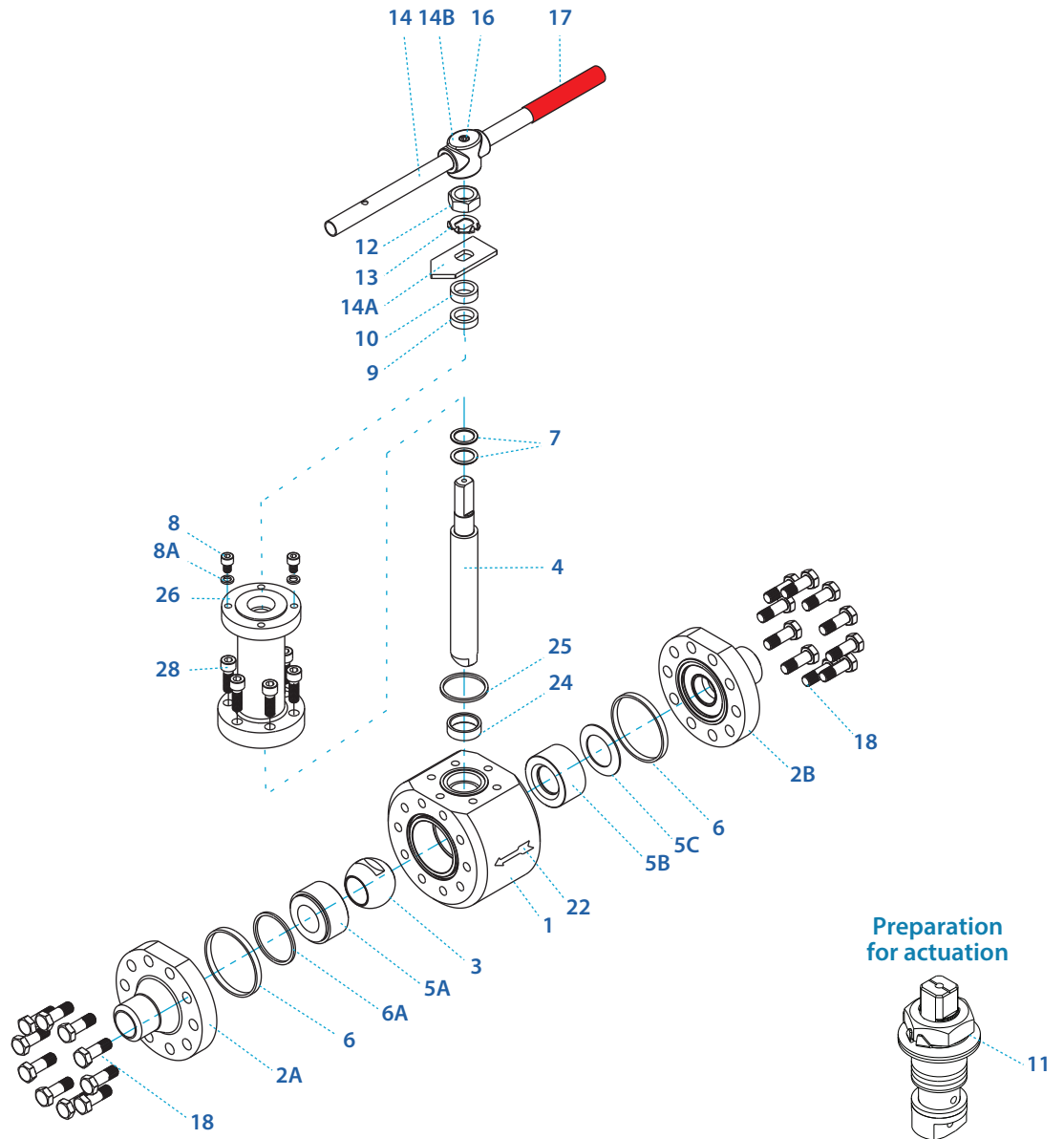

Item	Description	Material specification	Qty.
1	Body	A479 316H, A479 321H, A182 F22, B637 N07718 Inconel 718	1
2A	Downstream end	A479 316H, A479 321H, A182 F22, B637 N07718 Inconel 718	1
2B	Upstream end	A479 316H, A479 321H, A182 F22, B637 N07718 Inconel 718	1
3	Ball	Base material: A182 F316, A182 F316H, A182 F6A Coating: Cr3C2 - Chromium Carbide with Nickel Chrome binder (HVOF)	1
4	Stem	B637 N07718 Inconel 718	1
5A	Downstream seat	Base material: A182 F316, A182 F316H, A182 F6A Coating: Cr3C2 - Chromium Carbide with Nickel Chrome binder (HVOF).	1
5B	Upstream seat	Base material: A182 F316, A182 F316H, A182 F6A Coating: Cr3C2 - Chromium Carbide with Nickel Chrome binder (HVOF)	1
5C	Upstream seat spring	Inconel 718	1
6*	Body seal	Graphite	2
6B*	Seat seal	Graphite	1
7*	Stem thrust seal	A479 316L, Hardened with LTPN - Low Temperature Plasma carboNitriding technology. B637 N07718 Inconel 718	2
8	Stop pin	A582 303	1

Item	Description	Material specification	Qty.
9*	Stem seal	Graphite	1
10	Follower	B783 316L	1
11	Disc spring	A693 631 17-7PH	2
12	Stem nut	A194 8M, EN3506-2 A4-80	1
13	Tab lock washer	A240 304	1
14**	Handle	C.St. A29 G10200 Zinc plate, A240 430	1
14A	Stop plate	C.St. 1.0402 Zinc plate, A240 430	1
14B	Wrench head	Ductile Iron A536 Gr. 65-45-12, A216 WCB, A351 CF8M	1
16	Wrench bolt	EN3506-1 A2-70/A4-80, A193 Gr B8/B8M	1
17	Sleeve	PVC	1
18	Body bolts	A193 B8M, A193 B7 zinc plated, A534 660	16-52
22	Arrow flow	A167 304	1
23	Tag (not shown)	A167 304	1
24	Bonnet seal	Graphite	1
25	Stem Bearing	B637 N07718 Inconel 718 , Bonze	1
26	Bonnet	A479 316H, A479 321H, B637 N07718 Inconel 718	1
28	Bonnet bolts	A193 B8M, A534 660	6-12

* Repair kit components

** Gear operator should be used for size 3" DN80 and above (handle components are not included)

Floating Ball Valves

Metal seated valves

General

Up to
400 °C / 752 °F

Up to
538 °C / 1000 °F

Up to
650 °C / 1200 °F

Ordering
code system

Ordering code system

The HABONIM metal seated ball valve identification code

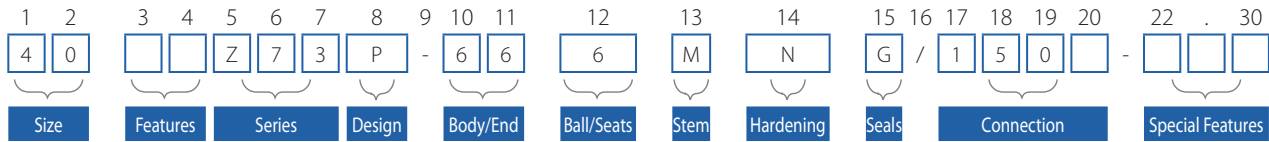

Size		
Code	inch	mm
02	1/4"	8
03	3/8"	10
05	1/2"	15
07	3/4"	20
10	1"	25
12	1 1/4"	32
15	1 1/2"	40
20	2"	50
25	2 1/2"	65
30	3"	80
40	4"	100
60	6"	150
80	8"	200

Features	
Z	Metal seats
F	Fire safe
B ⁽⁵⁾	Full port
N	Control
R	Flush tank

Series	
Z47	3 Pcs design
Z28	High pressure design
Z73	Flanged ANSI 150
Z74	Flanged ANSI 300
Z77	Flanged DIN PN16
Z78	Flanged DIN PN40

Design	
X	-60 °C to 230 °C (-76 °F to +446 °F) HermetiX™ stem seal
P ⁽⁴⁾	-60 °C to +400 °C (-76 °F to +752 °F)
T ⁽¹⁾	-60 °C to +538 °C (-76 °F to +1000 °F)
T ⁽¹⁾	-60 °C to +650 °C (-76 °F to +1200 °F)

Body / End connection	
4	ASTM A105 C.St A216 C.St WCB
6	ASTM A479 S.St. 316/316L ASTM A351 S.St CF8M/CF3M
F	ASTM A350 LF2 C.St
I	Inconel 625
P	ASTM A182 F22
U	ASTM A479 321
H	ASTM A479 321H
D	Duplex A995 CD3MN 4A
K	S.Duplex A995 CE3MN 5A
S	254SMO A351 CK3MCuN

Ball / Seats Set	
6	ASTM A479 S.St. 316 / 316L
G	ASTM A479 S.St. 316Ti
L	ASTM A479 S.St. 310H
N	ASTM A479 S.St. 410
D	D Duplex A479 S31803
K	S.duplex A479 S32750
S	254SMO A479 S31254

Stem	
M	S.St. 17-4PH
Z	Inconel 718

Hardening	
N	LTPN - Low Temperature Plasma carboNitriding
I	Cr ₃ C ₂ - Chromium Carbide with Nickel Chrome binder - HVOF technique
O	WC-Co - Tungsten Carbide with Cobalt binder - HVOF technique
E	Stellite - PTA technique

Seals	
G	Expanded graphite
B	NBR Sh. 90
V	Viton Sh. 70

Special Features	
V30 ⁽²⁾	Characterized control downstream seat
WR	DD Stem
FF	Flat facing
RTJ	Ring type joint facing
159	C ball
B	Rolled bar

End Connection ⁽³⁾	
BSPT	BS 21
DIN	DIN 2999 (BSPP)
NPT	B1.20.1
XBW	Extended butt weld
XSW	Extended Socket Weld
Flange connection	
ANSI B16.5 (B16.47 series A) - Raised Face 150, 300, 600, 900, 1500, 2500	
EN 1092 Pt.1&2 Raised Face PN16, PN25, PN40, PN64, PN100, PN250, PN400	

⁽¹⁾ The material code of construction identify between the two temperature segments.

⁽²⁾ For more information use Habonim control valves catalog.

⁽³⁾ Other end connections are available upon request.

⁽⁴⁾ Use 28 Series without the 'P' suffix.

⁽⁵⁾ Applicable for 47 series only.

It is essential to provide as many details possible on the application such as: media, temperature, pressure, pipe line size and type of connection.

In some applications the available options above are limited to specific sizes. Consult with Habonim for details.



www.habonim.com

Habonim ISRAEL

Tel: +972-4-6914911

Fax: +972-4-6914935

sales_international@habonim.com

Habonim EUROPE

Tel: +34 640 384 759

sales_eu@habonim.com

Habonim UK

Tel: +44-1633-484554

Fax: +44-1633-482252

sales_uk@habonim.com

Habonim USA

Toll Free Phone: 1-866-261-8400

Toll Free Fax: 1-866-243-9959

sales_usa@habonim.com

Habonim CHINA

Tel: + 86 21 64453190 *146

sales_china@habonim.com

Habonim AUSTRALIA

Tel: +61 3 9556 5428

sales_au@habonimau.com



www.habonim.com

Metal seated valves 02/17 REV203

MAXMARK

