

Sievers* M5310 C TOC Analyzers

operation and maintenance manual

2.00 firmware or later



Sievers M5310 C
Total Organic Carbon (TOC) Analyzers



Printed in the USA © 2020

**6060 Spine Road
Boulder, CO 80301 USA
www.sieversinstruments.com**

***For technical support, contact Technical Support or your local service provider.
In North America, contact Technical Support at +1 888 245 2595.
In Europe, the Middle East, and Africa, contact
Technical Support at +44 161 864 6800.***

***To order standards or replacement parts, contact Customer Care
at +1 800 255 6964 or your local service provider.***

***For a copy of the Declaration of Conformity and ISO 9001 Registration:
Visit our website (Library > Declarations of Conformity)
and (Company > ISO 9001 Certification).***

Electronic versions of the *Analyzer's Operation and Maintenance Manual*
and *M9 Qualification Packages* are available from our website (Library > Manuals).

Identification Records

Analyzer serial number¹:

Date Analyzer received and installed²:

-
1. The serial number is located on the rear panel of the Laboratory and Portable Analyzers, and on the side panel of the On-Line TOC Analyzer.
 2. This is the warranty date.

Table of Contents

Sievers M5310 C TOC Analyzers	17
<i>Document Revision History</i>	17
<i>Trademarks and Patents</i>	17
<i>Confidentiality</i>	18
<i>Standard Limited Warranty</i>	18
Chapter 1: Introduction	23
Chapter 2: System Overview	25
System Specifications	26
The Sample Flow	27
CO ₂ Transfer Modules	31
The Analyzer's Major Subsystems	32
Optional Configurations	33
Two-Stream Inlet	33
Accessories	34
Printer	34
Mouse	34
Sievers Autosampler	34
Sievers DataPro2 Software	34
Automated User and System Protocols	35
Secure Data	35
Chapter 3: Installation	37
Overview	37
Installation Instructions	37
Step 1: Unpack and Inspect the Analyzer	37
Packing List	38
Additional Equipment Requirements	39
Removing the DI Loop Shipping Bracket	40
Step 2: Complete the Identification Records	40
Step 3: Select a Location for the Analyzer	40
Sievers On-Line TOC Analyzer	41
Sievers Laboratory and Portable TOC Analyzers	42

Sievers Autosampler System	42
Step 4: Install the Reagent Cartridges	42
<i>To install the reagent cartridges (Opaque type) — Laboratory and Portable Analyzers</i>	44
<i>To install the reagent cartridges (Clear type) — Laboratory and Portable Analyzers . . .</i>	46
<i>To install the reagent cartridges (Opaque type) — On-Line TOC Analyzer</i>	47
<i>To install the reagent cartridges (Clear type) — On-Line TOC Analyzer</i>	48
Step 5: Install the DI Water System	49
<i>To fill the DI water reservoir</i>	50
<i>To install the resin cartridge</i>	52
Step 6: Install I/O Control Wiring (Optional)	53
Working with the Terminal Blocks	53
Wiring 4-20 mA and Alarm Outputs	53
<i>To install 4-20 mA and alarm outputs — On-Line TOC Analyzer</i>	54
<i>To install 4-20 mA and alarm outputs — Portable TOC Analyzer</i>	54
Working with Pinout Tables and Wiring Diagrams	55
J4 Terminal Wiring	56
J6 Terminal Wiring	56
Wiring the Remote Start (Binary Input)	57
J5 Terminal Wiring	57
<i>To install the binary input connections</i>	58
<i>To install the binary input connections — On-Line TOC Analyzer</i>	59
<i>To install the binary input connections — Portable TOC Analyzer</i>	60
Step 7: Install Power	61
Installing the Power Source	61
Power Cord Installation	61
Conduit Installation	62
<i>To wire the AC conduit</i>	62
Powering On and Off the Analyzer	64
<i>To power on the Analyzer</i>	64
<i>To power off the Analyzer</i>	64
Step 8: Prime the DI Pump	65
<i>To prime the DI Water pump</i>	65
Step 9: Install Ethernet and External Devices	67
Installing an Ethernet Connection	68
<i>To install the Ethernet Connection</i>	68
Installing a USB Connection	68
USB Device Port	69

<i>To install a USB connection — Device Port (Optional)</i>	69
USB Host Ports	69
<i>To install a USB Host port connection — Printer (Optional)</i>	69
<i>To install a USB Host port connection — Mouse (Optional)</i>	69
<i>To install a USB Host port connection — Portable USB memory drive</i>	70
<i>To install a USB Host port connection — Sievers Autosampler (Optional)</i>	70
Installing a Printer	70
<i>To install a USB printer</i>	70
Step 10: Install the iOS System	71
<i>To connect the inlet tubing to the iOS</i>	71
Step 11: Install the Waste Outlet— Laboratory TOC analyzer	75
<i>To install the waste outlet</i>	75
Step 12: Configure Basic Analyzer Settings	76
Enabling Password Protection (Optional)	77
<i>To enable Password Protection</i>	77
Naming the Analyzer Location (Optional)	78
<i>To name an Analyzer Location</i>	78
Setting Up the Data History Warning	78
<i>To set database backup and archiving reminders</i>	78
<i>To schedule automatic database archiving</i>	79
Configuring Ethernet Output	80
<i>To configure the Ethernet output</i>	80
Set Up the Printer (Optional)	80
<i>To enable printing from the Analyzer</i>	80
Set Up the USB Mouse (Optional)	81
<i>To interact with the Analyzer Using a USB Mouse</i>	81
Exporting System Constants	82
<i>To export system settings (constants)</i>	82
Configuring the Data I/O (Optional)	82
<i>To set up the Data I/O</i>	83
<i>To enable Binary Input (start/stop)</i>	84
<i>To configure the alarms</i>	84
Step 13: Flush and Rinse (optional) the Analyzer	85
<i>To flush and rinse the Analyzer</i>	85
Step 14: Install a Sievers Autosampler	89
Chapter 4: Operation	91
Overview	91

Sampling Using the iOS System	92
Two-Stream Operation	92
The Analyzer Screens	93
Overview of the Analyzer Screens	93
The Home Screen	95
User Defined Methods	96
Creating Grab Mode User-Defined Methods	96
<i>To create or change a user defined method — GRAB MODE</i>	96
<i>To create or change a TOC Removal Grab Method</i>	98
Creating On-Line User-Defined Methods	100
Using TOC Removal Online Measurement (Optional)	100
<i>To use the TOC Removal Online</i>	100
Using On-Line Timed Measurement	103
<i>To use the On-Line Time Measurement feature</i>	103
Creating an On-Line Mode Method	105
<i>To create or change a user defined method — ONLINE MODE</i>	105
Running a Sample Analysis	108
<i>To run a sample analysis</i>	108
Setting Reagent Rates	110
Autoreagent Mode	110
Manually Setting Flow Rates	110
Understanding Analysis Times	111
Viewing Consumables Levels	112
Reviewing Errors and Warnings	113
<i>To review a warning or error</i>	114
Shutting Down the Instrument	115
The Protocols Screen	115
System Protocols	116
User Defined Methods	116
<i>To run a sample analysis (Protocols screen)</i>	117
<i>To export user defined method details</i>	118
The Configuration Screen	119
Using the Result Preferences Tab	120
<i>To set result preferences</i>	120
Using the Environment Preferences Tab	121
<i>To set the language</i>	122
<i>To set preferences for warnings</i>	122
<i>To set other environment preferences</i>	123
Using the Keyword Search Tab	124
<i>To set keyword search options</i>	124
Using the System Setup Tab	125

Setting the System Clock	125
<i>To set the system clock</i>	125
Configuring Printer Setup	126
Configuring the Network Connection	126
<i>To configure the network connection</i>	126
Turning off the UV Lamp	127
<i>To temporarily turn off the UV lamp</i>	127
Configuring Flow Sensors	128
<i>To configure the flow sensors</i>	128
Configuring I/O Setup	129
4-20 mA Calibration Tab	129
4-20 mA Output Tab	129
Binary Input (Start/Stop) Tab	129
Alarm Output Tab	129
Configuring Online Setup	129
Manually setting the TOC Offset	130
The Maintenance Screen	131
Overview of the Maintenance Screen	131
The Consumables Tab	131
The IC Removal Tab	131
The Error History Tab	131
The Diagnostics Tab	132
The Advanced Tab	132
The Settings Tab	132
Reviewing Consumables Status	133
Reviewing IC Removal Consumables Status	134
Cleaning the Analyzer	134
<i>To clean the external housing</i>	134
<i>To clean the touchscreen</i>	134
Upgrading Firmware	135
<i>To upgrade firmware</i>	135
Archiving the Database	135
<i>To archive the database</i>	135
Backing Up the Database	135
<i>To back up the database</i>	136
Performing a Syringe Flush	136
<i>To perform a syringe flush</i>	136
Viewing Archive Files	136
<i>To view an archive file</i>	136
Restoring the Database	137
<i>To restore the database</i>	137
Creating Master Settings	138
<i>To create master settings</i>	138

Loading Master Settings	138
<i>To load master settings</i>	138
Backing Up Settings	138
<i>To back up settings</i>	138
Restoring Settings	139
<i>To restore settings</i>	139
Resetting Offset Default Values	140
The Data View Screen	140
<i>To view data history</i>	141
The Security Screen	142
The Help Screen	143
Chapter 5: Password Protection	145
Overview	145
Using Password Protection	145
Enabling Password Protection	145
<i>To enable or disable Password Protection</i>	146
<i>To log in using Password Protection</i>	146
<i>To change the password</i>	147
Chapter 6: Calibration	149
Overview	149
Using the Autoreagent Verification	150
Required Calibration Supplies	150
To Order	150
DI Water for Syringe Flush	150
Required Standards Lists	150
Standards Required for Single-Point Calibration	151
Standards Required for Multi-Point Calibration	151
Standards Required for Single-Point Verification	152
Standards Required for Autoreagent Verification	152
Preparing for Calibration	152
<i>To back up the database</i>	153
Backing Up Settings (Constants)	153
<i>To back up system settings (constants)</i>	153
Performing Annual Maintenance Tasks	154
Performing a TOC Autozero (optional)	154
<i>To perform a TOC Autozero (optional)</i>	155
System Protocols	157

Performing a Single-Point Calibration for Grab/On-Line Operation	157
<i>To perform a Single-Point Calibration</i>	158
Performing a Multi-Point Calibration for Grab/On-Line Operation	161
<i>To perform a Multi-Point calibration</i>	163
Performing a Single-Point Verification for Grab/On-Line Operation.	166
<i>To perform a Single-Point verification</i>	167
Performing an Autoreagent Verification for Grab/On-Line Operation (Optional)	170
<i>To perform an Autoreagent Verification</i>	171
Calibration History	173
Viewing Calibration History	174
<i>To view and export calibration/verification history</i>	174
Chapter 7: Maintenance	175
Overview.	175
Interior Views of the Analyzer.	176
On-Line Analyzer Views.	176
Laboratory Analyzer Views	178
Portable Analyzer Views	179
Monitoring Analyzer Maintenance	180
Monitoring Consumables Using the Home Screen	180
Monitoring Consumables Using the Maintenance Screen	181
Tracking and Renewing Consumables Expiration	181
Consumables Replacement Schedule	182
Annual Maintenance and Calibration Activities	182
Tracking Consumables Levels	185
Renewing Expiration Dates	185
<i>To renew an expiration date</i>	185
Replacing Reagents and Other Consumables	186
Replacing the Chemical Reagents.	186
<i>To replace a reagent cartridge (Opaque type) — Lab and Portable Analyzers</i>	188
<i>To replace a reagent cartridge (Clear type) — Lab and Portable Analyzers</i>	190
<i>To replace a reagent cartridge (Opaque type) — On-Line TOC Analyzer</i>	192
<i>To replace a reagent cartridge (Clear type) — On-Line TOC Analyzer</i>	193
Replacing other Consumables	195
<i>To replace the resin cartridge</i>	195
<i>To drain excess water from the DI water reservoir</i>	198
<i>To replace the UV Lamp</i>	200
<i>To replace the sample pump heads</i>	202
<i>To replace the in-line filter element</i>	205
Replacing ICR Consumables	208

Replacing the ICR Degasser	209
<i>To replace the ICR Degasser (Portable or Laboratory TOC Analyzer)</i>	209
<i>To replace the ICR Degasser (On-Line TOC Analyzer)</i>	210
Performing Routine Maintenance Tasks	211
Flushing Reagent Syringes	211
<i>To flush the reagent syringes</i>	211
Maintaining the DI Water Reservoir Level	212
<i>To fill the DI water reservoir</i>	212
<i>To drain excess water from the DI water reservoir</i>	214
Cleaning the Analyzer	215
<i>To clean the external housing</i>	215
<i>To clean the touchscreen</i>	215
Chapter 8: Troubleshooting	217
Overview.	217
Step 1: Review Failures, Warnings, and Errors	217
Reviewing the Self Check Summary	217
Reviewing Errors and Warnings.	218
<i>To review errors and warnings</i>	218
Step 2: Visual Inspection	220
Performing an External Inspection	221
Performing an Internal Inspection	221
Step 3: Review Solutions for Basic Problems	222
Reviewing Solutions for Basic Problems	222
Correcting Minor Sensor Differences.	222
<i>To perform a TC/IC Cell Conductivity Autozero (optional)</i>	223
The Analyzer Will Not Power On	224
<i>To replace the fuse in the power entry module</i>	224
Connection Problems to DataPro2 Software and Sievers Autosampler	226
<i>To re-establish connection to DataPro2 Software or the Sievers Autosampler</i>	226
Connection Problems Directly following a Sievers Autosampler Installation	228
<i>To verify the Sievers Autosampler cable connections</i>	228
Problems with the DI Pump	228
Lack of Flow.	229
<i>To check the sample pumps</i>	229
<i>To check the syringes</i>	231
<i>To check the valves</i>	232
<i>To check the inlet tubing</i>	233
<i>To prepare for the backflush</i>	233
<i>To test the DI fluidics side for obstruction</i>	236
Bubbles in Reagent Lines or Syringes.	236

pH of Waste Stream is Too High	237
Possible High pH Causes	237
Erratic Readings Due to High IC	237
Negative Measurements	237
<i>To manually set the TOC Offset</i>	238
Problems Changing the program language	238
<i>To change the program language</i>	239
Step 4: Perform Additional Diagnostics	241
Disabling the UV Lamp	241
<i>To disable the UV lamp</i>	241
Using the Diagnostics Tab	242
<i>To test the Ethernet connection</i>	243
<i>To test the USB connection</i>	246
Step 5: Obtain Technical Support.	248
Step 6: Return Analyzer to SUEZ.	248
<i>To prepare the Analyzer for travel</i>	249

Appendix A: SAFETY WARNINGS. 251

English	251
Hazardous Material Disposal	254
Operational Cautions	255
中文 (Chinese)	256
有害物质处理	259
操作注意事项	259
日本語(Japanese)	260
有害物質処分	263
操作上の注意	263
Deutsch	264
ENTSORGUNG VON GEFAHRSTOFFEN	268
VORSICHTSMASSNAHMEN BEIM BETRIEB	268
Français	269
MISE AU REBUT DES MATÉRIAUX DANGEREUX	272
PRÉCAUTIONS DE FONCTIONNEMENT	273
Italiano	275
SMALTIMENTO DI MATERIALI PERICOLOSI	278
AVVERTENZE PER IL FUNZIONAMENTO	278
Español	279
DESECHO DE MATERIALES PELIGROSOS	283
PRECAUCIONES OPERATIVAS	283

Appendix B: Protocol Worksheets 291

Documenting Calibration Results	291
Single-Point Calibration for Grab/On-Line Worksheet	293

Multi-Point Calibration for Grab/On-Line Worksheet	295
Single-Point Verification for Grab/On-Line Worksheet.	297
Autoreagent Verification for Grab/On-Line Worksheet.	299
Appendix C: Working with Modbus	301
An Introduction to Modbus	301
Implementing Modbus Communications on the Analyzer	301
<i>To verify the Modbus connection</i>	<i>302</i>
<i>To clear warnings and errors using Modbus.</i>	<i>303</i>
Modbus Map	303
Appendix D: Streaming Data Via Ethernet	311
<i>To stream data via Ethernet</i>	<i>311</i>
Appendix E: Warning and Error Descriptions	313

List of Tables

Table 1	Serial and 4-20 mA Outputs (J4)	56
Table 2	Alarm Outputs (J6)	57
Table 3	Binary Inputs (Terminal BlockJ5)	58
Table 4	The Analyzer's Standard Toolbar	94
Table 5	Recommended Oxidizer Flow Rates	110
Table 6	Recommended Acid Flow Rates — Sievers M5310 C TOC Analyzers . .	111
Table 7	Sample Analysis Time by Reagent Mode	111
Table 8	Standards Required for Single-Point Calibration	151
Table 9	Standards Required for Multi-Point Calibration	151
Table 10	Standards Required for Single-Point Verification	152
Table 11	Standards Required for Autoreagent Verification	152
Table 12	Consumables Replacement Schedule	182
Table 13	Verification / Calibration Activities after Consumables Replacement . . .	184
Table 14	Verification / Calibration Activities after Major Repair	184
Table 15	Connection Problem Types	226
Table 16	SUEZ Modbus Map	303
Table 17	Possible Mode Values	309

List of Figures

Figure 1	Sievers M5310 C TOC Analyzer System Specifications	26
Figure 2	Sievers M5310 C TOC Analyzer Schematic — On-Line and Portable Models . . .	27
Figure 3	Sievers M5310 C TOC Analyzer Schematic — Two-Stream On-Line Model	28
Figure 4	Sievers M5310 C TOC Analyzer Schematic — Laboratory Model.	29
Figure 5	Sample Flow through the CO ₂ Transfer Module	31
Figure 6	Required Installation Clearances — On-Line TOC Analyzer (Front View).	41
Figure 7	Required Installation Clearances — On-Line TOC Analyzer (Side View)	42
Figure 8	Identifying Reagent Cartridge Types	44
Figure 9	Metal Port Latches	50
Figure 10	Assembled Filling Fixture	50
Figure 11	Filling the DI Water Reservoir	51
Figure 12	DI Reservoir Level with Float	51
Figure 13	Resin Cartridge — Position for Priming	52
Figure 14	Wiring 4-20 mA Connections	55
Figure 15	Wiring Option for Binary Input — Using Analyzer’s Internal Supply.	58
Figure 16	Wiring Option for Binary Input — Using External Supply.	59
Figure 17	Wiring AC Power Conduit	63
Figure 18	Viewing the Reservoir Water Level	66
Figure 19	DI Reservoir Cartridge — “Prime” and “Run” Positions	67
Figure 20	iOS	73
Figure 21	iOS — (Optional) Two Stream	74
Figure 22	Waste Outlet Fitting — Laboratory TOC Analyzer	76
Figure 23	iOS — <i>On-Line and Portable TOC Analyzers</i>	92
Figure 24	The Standard Toolbar	93
Figure 25	The Home Screen	95
Figure 26	Consumable Level Indicators.	112
Figure 27	Consumables Tab	112
Figure 28	The Home Screen — Warning and Error Indicator	113
Figure 29	The Shut Down Button.	115
Figure 30	The Configuration Screen	119
Figure 31	The Result Preferences Tab	120
Figure 32	The Environment Preferences Tab	121
Figure 33	The Keyword Search Tab	124
Figure 34	The Maintenance Screen.	131
Figure 35	The Consumables Tab.	133
Figure 36	The IC Removal Tab	134

Figure 37	The Data History Tab	140
Figure 38	Password Protection Screen	142
Figure 39	The Help Screen	143
Figure 40	TOC Autozero Setup	155
Figure 41	The Data View Screen	174
Figure 42	Interior Overview — Sievers M5310 C On-Line TOC Analyzer	176
Figure 43	Electronics Enclosure (Top Shelf) — Sievers M5310 C On-Line TOC Analyzer	177
Figure 44	Electronics on Inside Door — Sievers M5310 C On-Line TOC Analyzer	177
Figure 45	Fluidics Side — Sievers M5310 C Laboratory TOC Analyzer	178
Figure 46	Electronics Side — Sievers M5310 C Laboratory TOC Analyzer	178
Figure 47	Fluidics Side — Sievers M5310 C Portable TOC Analyzer	179
Figure 48	Electronics Side — Sievers M5310 C Portable TOC Analyzer	179
Figure 49	The Home Screen with Consumables Levels	180
Figure 50	The Maintenance Screen with Consumables Tab	181
Figure 51	Identifying Reagent Cartridge Types	188
Figure 52	Resin Cartridge — “Prime” and “Run” Positions	198
Figure 53	Water Reservoir with Float.	200
Figure 54	Sample Pump Heads and Tubing — TC Side	203
Figure 55	Sample Pump Heads and Tubing — IC Side.	204
Figure 56	iOS — One Stream	206
Figure 57	iOS — (Optional) Two Stream	207
Figure 58	ICR Bracket	209
Figure 59	ICR Bracket	210
Figure 60	Filling the DI Pump.	213
Figure 61	DI Reservoir Level with Float.	213
Figure 62	<i>Self Check</i> Dialog Boxes	218
Figure 63	Stream Splitters and Valves.	222
Figure 64	Power Entry Component with Fuse Compartment.	224
Figure 65	The Sievers Autosampler Fuse Housing	225
Figure 66	Sample Pumps.	229
Figure 67	TC/IC Y-Connector	234
Figure 68	Backflushing the Sample Side	236
Figure 69	The Diagnostics Tab	242
Figure 70	Connecting the Ethernet Cable — Portable and Laboratory Analyzers.	244
Figure 71	Internal Ethernet Ports — On-Line TOC Analyzer.	244
Figure 72	Ethernet Port on DUC board	245
Figure 73	PuTTy Screen	311

Sievers M5310 C TOC Analyzers

DOCUMENT REVISION HISTORY

Document Version	Firmware/Software Version	Date
DLM 77100-01 EN Rev. B	1.02 Firmware / 1.01 Software Product Release	May 2014
DLM 77100-01 EN Rev. C	1.03 Firmware / 1.01 Software Product Release	June 2014
DLM 77100-01 EN Rev. D	1.04 Firmware / 1.02 Software	November 2014
DLM 77100-02 EN Rev. A	1.05 Firmware / 1.02 Software	February 2015
DLM 77100-03 EN Rev. A	1.06 Firmware / 1.03 Software	June 2015
DLM 77100-04 EN Rev. A	1.07, 1.08 Firmware / 1.05 Software	June 2016
DLM 77100-05 EN Rev. A	1.10 Firmware / 1.07 Software	December 2017
DLM 77100-06 EN Rev. A	1.11 Firmware / 1.08 Software	April 2018
DLM 77120-01 EN Rev. A	2.00 Firmware / 2.00 Software	December 2020

TRADEMARKS AND PATENTS

Sievers[®], DataPro2[®], and DataGuard[®] are trademarks of SUEZ and may be registered in one or more countries.

Allen[®] is a trademark of the Allen Manufacturing Company; HyperTerminal[®] is a registered trademark of Hilgraeve; Norprene[®] is a registered trademark of Norton Performance Plastics Corporation; Swagelok[®] is a registered trademark of the Swagelok Company; TORX[®] is a registered trademark of Acument Intellectual Properties, LLC. Microsoft Windows[®], Windows XP[®], Windows Vista[®], Microsoft[®], Excel[®], Microsoft Edge[®], and Internet Explorer[®] are registered trademarks of Microsoft Corporation.

The Analyzer described in this manual is covered by one or more patents issued to and owned or pending by SUEZ, including the following:

US 6723565 and any of their non-US counterparts
US 8101417 and any of their non-US counterparts
US 8003048 and any of their non-US counterparts
US 9116099 and any of their non-US counterparts
US 9074967 and any of their non-US counterparts
and other patents pending

CONFIDENTIALITY

The information contained in this manual may be confidential and proprietary and is the property of SUEZ. Information disclosed herein shall not be used to manufacture, construct, or otherwise reproduce the goods disclosed herein. The information disclosed herein shall not be disclosed to others or made public in any manner without the express written consent of SUEZ.

STANDARD LIMITED WARRANTY

SUEZ warrants its Sievers[®] products for defects in materials and workmanship. SUEZ will, at its option, repair or replace instrument components that prove to be defective with new or remanufactured components. The warranty set forth is exclusive and no other warranty, whether written or oral, is expressed or implied.

WARRANTY TERM

The SUEZ warranty term is thirteen (13) months ex-works, or twelve (12) months from installation or start up by SUEZ-certified service personnel. In no event shall the standard limited warranty coverage extend beyond thirteen (13) months from original shipment date.

WARRANTY SERVICE

Warranty Service is provided to customers through telephone support, Monday - Friday, from 8:00 a.m. to 5:00 p.m. (Mountain Time), excluding all company and legal holidays. Telephone support is provided for troubleshooting and determination of parts to be shipped from SUEZ to the customer in order to return the product to operation. If telephone support is not effective, the product may be returned to SUEZ for repair or replacement. In some instances, suitable instruments may be available for short duration loan or lease.

SUEZ warrants that any labor services provided shall conform to the reasonable standards of technical competency and performance effective at the time of delivery. All service interventions are to be reviewed and authorized as correct and complete at the completion of the service by a customer representative, or designate. SUEZ warrants these services for 30 days after the authorization and will correct any qualifying deficiency in labor provided that the labor service deficiency is exactly related to the originating event. No other remedy, other than the provision of labor services, may be applicable.

Repair components (parts and materials), but not consumables, provided in the course of a repair, or purchased individually, are warranted for 90 days ex-works for materials and workmanship. In no event will the incorporation of a warranted repair component into an instrument extend the whole instrument's warranty beyond its original term.

Consumables (e.g., dilution standards, verification solutions, and UV lamps, etc.) are warranted to the extent of their stated shelf life, provided these items are maintained within the stated

environmental limitations. Warranty claims for consumables and verification standards are limited to the replacement of the defective items, prorated from the time of claim to the expiration of shelf life.

SHIPPING

A Repair Authorization Number (RA) must be obtained from the Technical Support Group before any product can be returned to the factory. SUEZ will pay freight charges, exclusive of any taxes and duties, for replacement or repaired products shipped to the customer site. Customers shall pay freight charges, including all taxes and duties, for all products returning to SUEZ. Any product returned to the factory without an RA number will be returned to the customer.

LIMITATION OF REMEDIES AND LIABILITY

The foregoing warranty shall not apply to defects resulting from improper or inadequate installation, maintenance, adjustment, calibration, or operation by customer. Installation, maintenance, adjustment, calibration, or operation must be performed in accordance with instructions stated in the Operation and Maintenance Manual. Usage of non-recommended maintenance materials may void a warranty claim.

The remedies provided herein are the customer's sole and exclusive remedies. In no event shall SUEZ be liable for direct, indirect, special, incidental or consequential damages (including loss of profits) whether based on contract, tort, or any other legal theory. The Operation and Maintenance Manual is believed to be accurate at the time of publication and no responsibility is taken for any errors that may be present. In no event shall SUEZ be liable for incidental or consequential damages in connection with or arising from the use of the manual and its accompanying related materials. Warranty is valid only for the original purchaser. This Limited Warranty is not transferable from the original purchaser to any other party without the express written consent from SUEZ. SUEZ specifically disclaims the implied warranties of merchantability and fitness for a particular purpose.

LIMITACIÓN DE REMEDIOS Y RESPONSABILIDAD

La garantía anterior no se aplicará a los defectos que resulten de la realización incorrecta o inadecuada de la instalación, el mantenimiento, el ajuste, la calibración o el manejo por parte del cliente. La instalación, el mantenimiento, el ajuste, la calibración o el manejo deberán llevarse a cabo de acuerdo con las instrucciones indicadas en el manual de funcionamiento y mantenimiento. El uso de materiales de mantenimiento que no sean los recomendados puede anular una reclamación de garantía.

Los remedios que aquí se indican serán los únicos los remedios para el cliente. En ningún caso GSUEZ será responsable de daños directos, indirectos, especiales, incidentales o consecuentes (incluida la pérdida de beneficios) ya sean contractuales, extracontractuales o basado en cualquier otra teoría legal. Se considera que el manual de funcionamiento y mantenimiento es exacto en el momento de su publicación y no se acepta ninguna responsabilidad por los errores

que pueda contener. En ningún caso será SUEZ responsable de los daños incidentales o consecuentes que resulten o estén relacionados con el uso del manual y los materiales que lo acompañan. La garantía es únicamente válida para el comprador original. El comprador original no puede transferir esta garantía limitada a ninguna otra parte sin el consentimiento expreso por escrito de SUEZ. SUEZ renuncia específicamente a las garantías implícitas de comercialización e idoneidad para un determinado propósito.

LIMITES DE CORRECTION ET DE FIABILITÉ

La garantie susdite ne s'applique pas aux défauts résultants d'une installation, d'une maintenance, d'un réglage, d'un calibrage ou d'un fonctionnement inapproprié, opéré par l'utilisateur. L'installation, la maintenance, le réglage, le calibrage ou le fonctionnement doit être réalisé conformément aux instructions du manuel de l'utilisateur et de maintenance. La mise en œuvre de procédures de maintenance non recommandées peut annuler toute disposition de garantie.

Les procédures de correction indiquées dans le présent document sont les seuls remèdes du client. Le groupe SUEZ ne saurait en aucun cas être tenu pour responsable de tout préjudice direct, indirect ou spécial de quelque nature que ce soit (y compris, les pertes de bénéfices), qu'il soit fondé sur un contrat, sur un acte dommageable ou sur une autre théorie légale. Le manuel de l'opérateur et de maintenance est aussi précis que possible au moment de la publication et la responsabilité du groupe ne saurait être engagée pour les éventuelles erreurs qu'il pourrait contenir. Le groupe SUEZ ne saurait en aucun cas être tenu pour responsable des préjudices accidentels ou de quelque nature que ce soit, dus à l'utilisation du manuel ou de la documentation connexe. La garantie ne s'applique qu'à l'acquéreur d'origine. La garantie limitée ne peut être transférée par l'acquéreur d'origine à une autre partie sans l'autorisation expresse écrite du groupe SUEZ. SUEZ exclut tout particulièrement les garanties implicites de commercialisation et d'adaptabilité dans un but spécifique.

BESCHRÄNKTE ANSPRÜCHE UND HAFTUNG

Die vorangehende Garantie gilt nicht für Schäden, die aus unsachgemäßer oder unzureichender Installation, Wartung, Anpassung, Kalibrierung oder Betrieb durch den Kunden resultieren. Installation, Wartung, Anpassung, Kalibrierung oder Betrieb müssen gemäß den Anweisungen in der Bedienungsanleitung durchgeführt werden. Durch die Verwendung von nicht empfohlenen Wartungsmaterialien kann der Garantieanspruch erlöschen.

Die hier erwähnten Ansprüche beziehen sich auf die einzigen und ausschließlichen Ansprüche des Kunden. SUEZ ist unter keinen Umständen verantwortlich für direkte, indirekte, besondere, zufällig entstandene oder Folgeschäden (einschließlich Verlust von Einkünften), die auf Vertrag, unerlaubten Handlungen oder andere Rechtstheorien basieren. Die Bedienungsanleitung ist zur Zeit der Veröffentlichung nach bestem Wissen korrekt, und es wird keine Verantwortung für mögliche vorhandene Fehler übernommen. SUEZ ist unter keinen Umständen haftbar für zufällige oder Folgeschäden, die in Verbindung mit oder durch die Verwendung der Bedienungsanleitung und begleitender Materialien entstehen. Die Garantie gilt nur für den ursprünglichen Käufer. Die beschränkte Garantie lässt sich nicht ohne ausdrückliche schriftliche Genehmigung von SUEZ vom ursprünglichen Käufer auf eine andere Person übertragen. SUEZ

schließt besonders die konkludente Garantie der Handelsüblichkeit und Eignung für einen bestimmten Zweck aus.

LIMITAZIONE DI RIMEDI E RESPONSABILITÀ

La precedente garanzia non è valida per difetti risultanti da installazione, manutenzione, regolazione, taratura o utilizzo improprio o inadeguato da parte dell'utente. L'installazione, la manutenzione, la regolazione, la taratura o l'utilizzo deve essere conforme alle istruzioni indicate nel manuale d'uso e manutenzione. L'utilizzo di materiali di manutenzione diversi da quelli consigliati rende nullo un reclamo in garanzia.

Gli unici rimedi spettanti all'utente sono quelli qui inclusi. In nessun caso SUEZ sarà responsabile per danni diretti, indiretti, speciali, accidentali o consequenziali (inclusa la perdita di profitti) risultanti dall'applicazione del contratto, atto illecito o altra teoria legale. Il manuale d'uso e manutenzione è accurato al momento della pubblicazione e l'azienda non si assume alcuna responsabilità per la presenza di eventuali errori. In nessun caso SUEZ sarà responsabile per danni accidentali o consequenziali correlati o derivanti dall'utilizzo del manuale e di altro materiale di supporto correlato. La garanzia è valida solo per l'acquirente originale. La presente garanzia limitata non è trasferibile dall'acquirente originale a terzi senza l'esplicito consenso scritto da parte di SUEZ. SUEZ declina espressamente le garanzie implicite di commerciabilità e idoneità a un particolare scopo.

限定責任および救済

前述の保証は、お客様による不適切または不十分な取り付け、保守、調整、校正、あるいは操作によって生じた不具合には適用されないものとします。取り付け、保守、調整、校正、または操作は、Operation and Maintenance Manual（操作取扱説明書）に記載されている指示に従って行う必要があります。推奨外の保守資材を使用すると、保証請求が無効になる場合があります。

ここで提供される救済は、お客様の唯一の排他的救済となります。SUEZ は、いかなる場合においても、直接的、間接的、特別的、付随的、または派生的損害（利益の逸失を含む）に対し、それが契約、不法行為、またはその他の法的理論に基づくものであるかどうかにかかわらず、一切責任を負いません。Operation and Maintenance Manual（操作取扱説明書）は、出版された時点で正確であるものと考えられており、万が一発生した誤りに対する責任は一切負いません。SUEZ は、いかなる場合においても、マニュアルまたはそれに付属の関連資料の使用に関連して、またはその使用が原因で発生した付随的または派生的損害にも一切責任を負いません。保証は最初の購入者に対してのみ有効です。本限定保証を、SUEZ の書面による同意なしに、最初の購入者から第三者に譲渡することはできません。SUEZ は、商品性および特定の目的に対する適合性の黙示の保証を一切拒否します。

赔偿与责任限制

上述保证不适用于因客户不正确或不恰当的安装、维护、调整、校准或操作导致的故障。安装、维护、调整、校准或操作必须遵循操作与维护手册中的说明进行。使用非推荐的维护材料可能会导致保证失效。这里提供的赔偿为客户的唯一和独占赔偿。在任何情况下，SUEZ 不对任何直接的、间接的、特殊的、偶发的或连带发生的损失（包括利润损失）负责，无论这些损害是依据何种合同责任理论、侵权行为责任理论或其它法律理论进行推断的。操作与维护手册在出版时被认为是

准确的，SUEZ 不对其中可能存在的任何错误负责。在任何情况下，SUEZ 均不对因使用该手册（或与其使用有关）或相关材料导致的偶发或连带发生的损失负责。保证仅对原购买者有效。未经 SUEZ 明确书面同意，此有限保证不可由原购买者转让给任何其他方。SUEZ 特此声明不提供任何关于特殊用途的适销性和适用性的暗示担保。

1

INTRODUCTION

The Sievers M5310 C TOC Analyzers from SUEZ are designed to measure the concentration of total organic carbon (TOC), total inorganic carbon (TIC), and total carbon (TC = TOC + TIC) in water samples.

The Analyzer oxidizes organic compounds to form carbon dioxide (CO₂) using UV radiation and a chemical oxidizing agent (ammonium persulfate). CO₂ is measured using a sensitive, selective membrane-based conductometric detection technique as described by Godec *et al.* (R. Godec *et al.*, "Method and Apparatus for the Determination of Dissolved Carbon in Water," U.S. Patent No. 5,132,094).

For each TOC measurement, the concentration of inorganic carbon species (CO₂, HCO₃⁻, and CO₃⁻²) is determined and, after oxidation of the organic compounds, the total carbon (TC) content of the sample is measured. The concentration of the organic compounds is then calculated from the difference between the concentrations of TC and total inorganic carbon (TIC), generally referred to simply as inorganic carbon (IC).

$$\text{TOC} = \text{TC} - \text{IC}$$

You can use the Analyzer to monitor water samples ranging from high-purity water containing 4 parts per billion (ppb) TOC to water samples containing up to 50 parts per million (ppm) TOC. The Analyzer is easy to operate, with extremely low maintenance, and requires no special training or chemical knowledge. The Analyzer is calibrated at the factory, and calibration remains stable for approximately one year. Recalibration and validation is easily performed onsite.

This manual presents operation and maintenance information for the Sievers M5310 C TOC Analyzers. This information, including step-by-step instructions, applies to ALL three models (*On-Line*, *Lab*, and *Portable*), except where specifically noted.

THIS PAGE IS INTENTIONALLY LEFT BLANK.

2

SYSTEM OVERVIEW

.....

This chapter provides an overview of the Sievers M5310 C TOC Analyzers, including:

- [System Specifications](#)
- [The Analyzer's Major Subsystems](#) — Sample Inlet System, Inorganic Carbon Remover (ICR), Chemical Reagent System, UV Reactor, CO₂ Measurement Module, Fluidics Module, and Electronics
- [Optional Configurations](#) — [Two-Stream Inlet](#)
- [Accessories](#) — [Printer](#), [Sievers Autosampler](#)

Chapter 2 SYSTEM OVERVIEW

System Specifications

	M5310 C Laboratory Analyzer	M5310 C On-Line Analyzer	M5310 C Portable Analyzer
operating specifications			
Range	4 ppb to 50 ppm		
Precision	<1% RSD		
Accuracy	± 2% or ± 0.5 ppb, whichever is greater		
Sample Type	Autosampler or discrete grab sample and TOC removal grab	On-line continuous or discrete grab sample, timed on-line, TOC removal on-line, TOC removal grab	On-line continuous, Autosampler, or discrete grab sample, timed on-line, TOC removal grab
Display Readout	3 significant digits		
Calibration	Typically stable for 12 months		
Analysis Time	2 minutes		
Sample Temperature	5-60 °C (41-140 °F)		
Ambient Temperature	5-40 °C (41-104 °F)		
Sample Pressure	N/A	100 psig	
On-Line Flow Rate	N/A	>50 mL/min (for on-line mode)	
Instrument Sample Flow Rate	0.5 mL/min		
analyzer specifications			
On-Line Inlet(s)	N/A	One stream, or 2-stream inlet (option)	One stream
Outputs	USB device port (1), USB host ports (3), Ethernet	4-20 mA outputs (3); alarm outputs (4); binary input (1); USB device port (1), USB host ports (2); Ethernet TCP/IP	
Display	7" WVGA 800x480 pixel, Color LCD w/ touch-screen		
Power	100 – 240 V~, 50 – 60 Hz, 100 VA		
Fuses	Replace with same type and size fuse: T 1.6 A 250 VAC Fuse (Slow Blow), size 5 x 20 mm appliance inlet		
Dimensions	H: 42.2 cm (16.6 in.); W: 24.6 cm (9.7 in); D: 40.0 cm (15.8 in)	H: 54.9 cm (21.6 in); W: 45.0 cm (17.7 in); D: 26.5 cm (10.4 in)	H: 39.5 cm (15.4); W: 22.9 cm (9.0 in); D: 46.4 cm (18.3 in)
Weight	10.0 kg (22.0 lb)	16.2 kg (35.6 lb)	9.8 kg (21.6 lb)
Enclosure Rating	N/A	IP-45	IP-21
Safety Certifications	ETL. CE		
environment			
Maximum Relative Humidity	0 - 95%, non-condensing		
Maximum Altitude	3,000 m (9,800 ft)		
Pollution Degree	2		

 The UV lamp inside this product contains mercury and must be recycled or disposed of in accordance with local, state, and federal laws.

Figure 1: Sievers M5310 C TOC Analyzer System Specifications

The Sample Flow

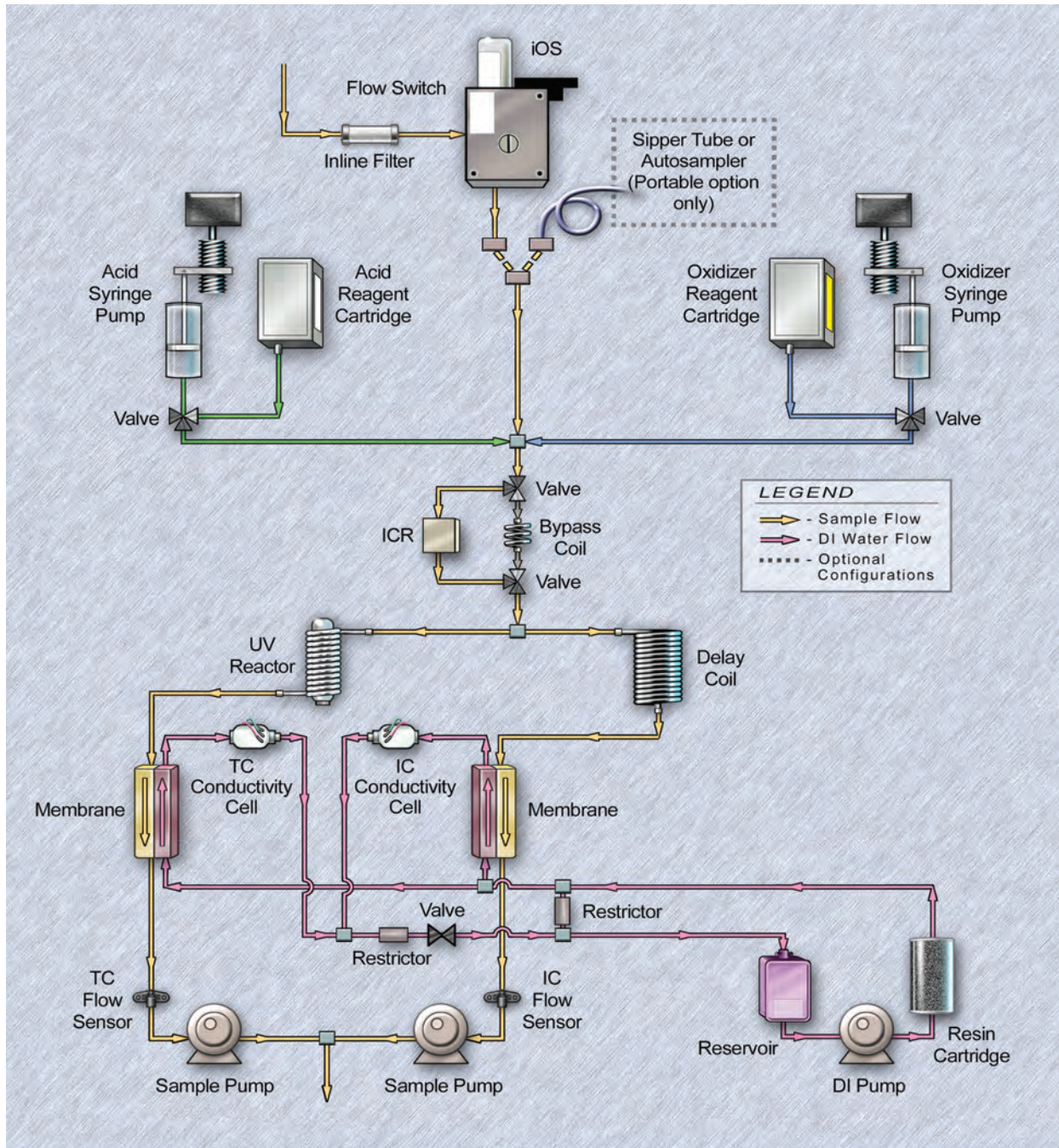

Figure 2: Sievers M5310 C TOC Analyzer Schematic — On-Line and Portable Models

Chapter 2 SYSTEM OVERVIEW

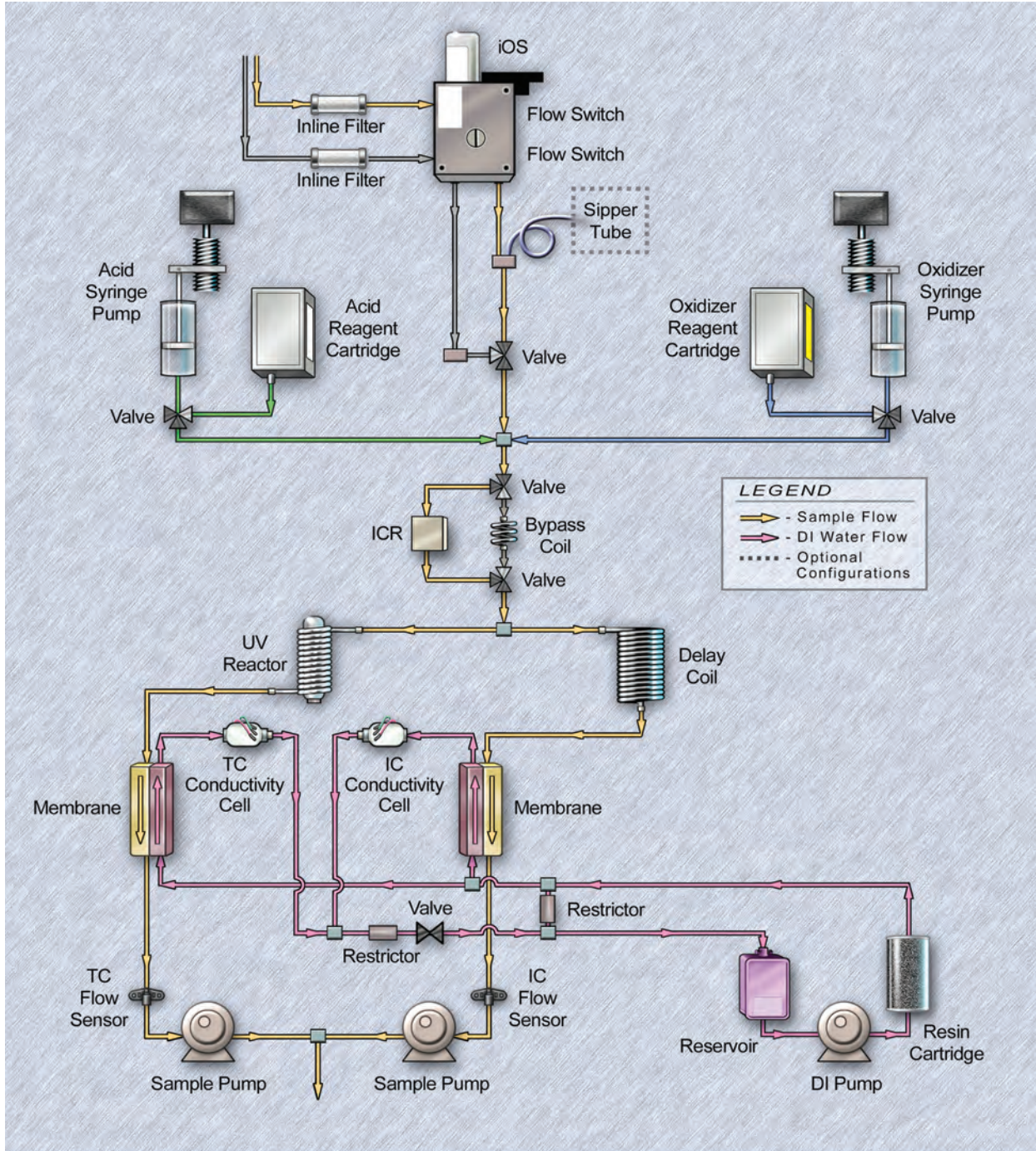

Figure 3: Sievers M5310 C TOC Analyzer Schematic — Two-Stream On-Line Model

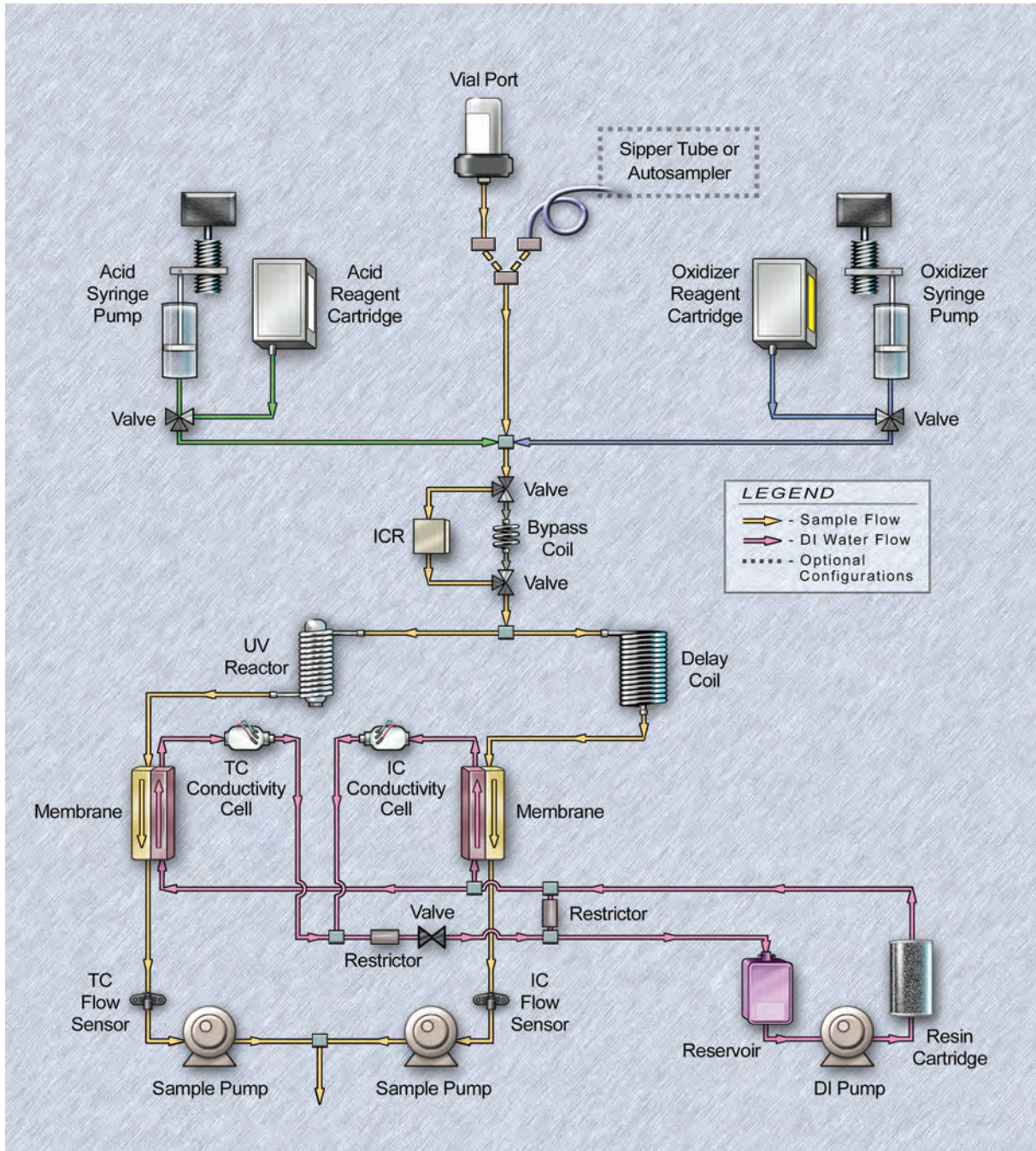

Figure 4: Sievers M5310 C TOC Analyzer Schematic — Laboratory Model

Samples are introduced to the Analyzer as follows:

- **On-Line TOC Analyzer** — Measure continuously by plumbing a sample line to the inlet of the iOS system or measure discrete grab samples by inserting a sample vial into the iOS system.

Chapter 2 SYSTEM OVERVIEW

- **Laboratory TOC Analyzer** — Measure discrete grab samples by inserting a sample vial into the vial port located on the front of the Analyzer, or via a sipper tube. You can also use the optional Sievers Autosampler to automate the analysis of a large number of samples.
- **Portable TOC Analyzer** — Measure discrete grab samples by inserting a sample vial into the iOS System¹, or via a sipper tube bypassing the iOS System. You can also use the optional Sievers Autosampler to automate the analysis of a large number of samples.

After sample is introduced into the Analyzer, the Analyzer injects 6M phosphoric acid (H_3PO_4) into the sample² at a programmed flow rate to reduce the sample pH to approximately 2. This allows for accurate measurement of TC and IC.

The Analyzer then combines the acidified sample with 15% ammonium persulfate [$(NH_4)_2S_2O_8$] to promote oxidation^{3, 4} of the organics. The sample travels through a mixing coil and on to a stream splitter.

The optional Inorganic Carbon Remover (ICR) may also be used to remove excess IC by degasification. See [“The Analyzer’s Major Subsystems” on page 32](#). If using the ICR unit, you may need to add additional acid to the sample to remove excess IC by the ICR.

The stream splitter divides the sample stream into two equal, but separate flows. One stream is processed for the measurement of IC. The other is processed for measurement of TC.

The TC stream passes to an oxidation reactor where the sample is exposed to UV light. The combination of UV light and (depending on the application) persulfate oxidizes the organic compounds in the sample, converting carbon to CO_2 .

The reactor is a spiral quartz tube wrapped around a UV lamp. The UV lamp emits light at 185 nm and 254 nm resulting in the formation of powerful chemical oxidizing agents in the form of hydroxyl radicals produced by the photolysis of water (equation 1) and persulfate (equations 2 and 3):

-
1. The preferred methods for sampling are on-line and grab sampling using the iOS system or vial port. Testing using a grab method with a sipper tube and laboratory glassware shows additional risk for contamination by sample preparation and handling. Contamination can be minimized with this method by using good sampling techniques including covering the open portion of the glassware. For additional information, reference SUEZ “On-Line or Grab Sample Monitoring” Application Note 300 00001 Rev. A, 2005.
 2. The phosphoric acid is referred to as *Acid* in the user interface.
 3. Depending on the application, some samples do **not** require the addition of persulfate. For example, when the TOC concentration in the sample is low (<1 ppm), complete oxidation can usually be achieved using only the hydroxyl radicals from the photolysis of water.
 4. The ammonium persulfate is referred to as *Oxidizer* in the user interface.



The hydroxyl radicals (OH·) will completely oxidize organic compounds, converting the carbon atoms of the organic compound into CO₂ (equation 4):

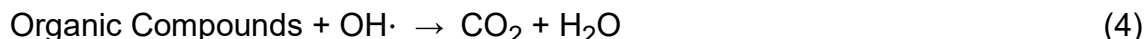

When the TOC concentration in the sample is low (<1 ppm), complete oxidation can usually be achieved using only the hydroxyl radicals from the photolysis of water (example 1) without the addition of persulfate.

The IC stream passes through a delay coil, which is designed to make the total transit time of the IC stream through the Analyzer the same as the transit time of the TC stream through the Analyzer.

CO₂ Transfer Modules

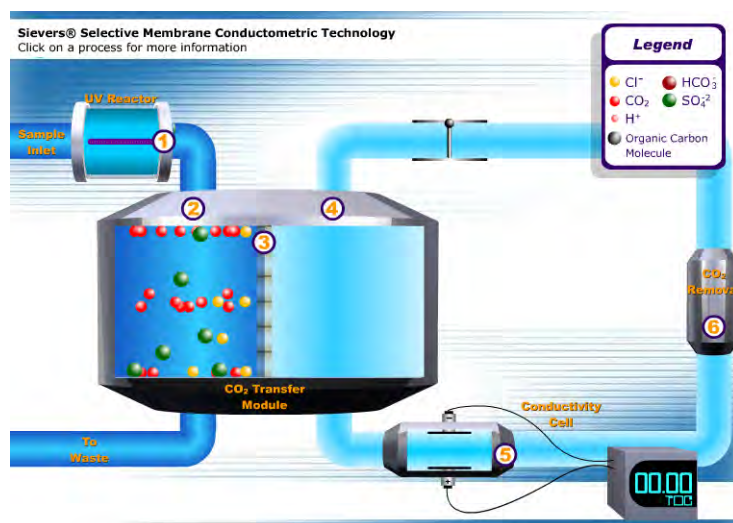

Figure 5: Sample Flow through the CO₂ Transfer Module

When the TC stream exits the oxidation reactor and the IC stream exits the delay coil, each stream moves to separate the CO₂ Transfer Module. The CO₂ Transfer Module is the SUEZ patented *Sievers Selective Membrane Conductometric* design, utilizing a gas-permeable membrane that separates CO₂ from the sample. A graphic depiction of this technology is shown in [Figure 5: Sample Flow through the CO₂ Transfer Module on page 31](#).



NOTE: If you are reading this manual in an Adobe® PDF® format, click the [Figure 5](#) graphic to activate the flow animation, and click any of the numbered processes for more information.

Chapter 2 SYSTEM OVERVIEW

The membrane separates the sample side of the Analyzer from the deionized (DI) water side. The DI side of the Analyzer is a closed loop, and consists of two conductivity cells (*one for the TC stream and one for the IC stream*), a DI pump, a DI water reservoir, and an ion exchange resin bed.

CO₂ from the sample passes through the membrane into the DI water supplied by the integrated DI Loop, while interfering compounds and other oxidation by-products are blocked by the membrane and remain on the sample side. The CO₂ forms carbonic acid upon reaction with water, and the carbonic acid disassociates into hydrogen ions and bicarbonate ions (equation 5):

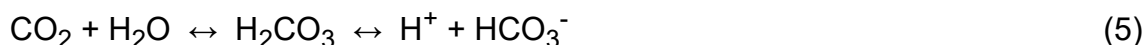

DI water is continuously pumped through the DI side of the Analyzer, collecting the H⁺ and HCO₃⁻ ions and H₂CO₃ and CO₂ molecules from the CO₂ transfer modules, delivering it to the conductivity cell for measurement. Then the ion exchange resin removes the HCO₃⁻ and other ions. The water is then pumped back to the CO₂ transfer module to repeat the sequence.

The TC and IC conductivity cells each contain a thermistor, and all conductivity readings are temperature corrected. The CO₂ from the TC and IC sample streams are measured by the respective conductivity cells, and the conductivity readings are used to calculate the concentration of TC and IC. After the values are measured, TOC is calculated as the difference (equation 6):

$$\text{TOC} = \text{TC} - \text{IC} \quad (6)$$

The Analyzer's Major Subsystems

The Sievers M5310 C TOC Analyzers consist of seven major subsystems. A brief summary about each subsystem follows:

- **Sample Inlet System**—This system includes a dual pump system and a one or two-stream sample line connection to the Analyzer's *Sample Inlet* ports for on-line sampling. The two-stream inlet option enables efficient sampling of two independent sample sources, without the need to alter the initial inlet setup. Measure discrete grab samples by placing a sample vial in the Integrated On-Line Sampling (iOS) System on On-Line and Portable Analyzers or the vial port of the *Laboratory TOC Analyzer*. You can connect the optional Sievers Autosampler system to the *Sample Inlet* port of *Laboratory and Portable TOC Analyzers* for high-volume laboratory applications.
- **Inorganic Carbon Remover (ICR)**—The ICR consists of a Teflon[®] degassing module used to increase accuracy when measuring water with high inorganic carbon (IC) content.
- **Chemical Reagent System**—This system includes reagent reservoirs and syringe pumps used to deliver chemical reagents into the sample.

- **UV Reactor**—The reactor is a spiral quartz tube wrapped around an ultraviolet (UV) lamp used to oxidize the sample.
- **CO₂ Measurement Module**—This module consists of a CO₂ Transfer manifold (a fluidics block with separate TC and IC channels to the gas-permeable membranes, that allows the transfer of CO₂) two quartz conductivity cells (one for the TC channel and the other for the IC channel), and a Dual Conductivity Signal Processor (DCSP) for processing data from each TC and IC channel.
- **Fluidics Module**—The fluidics module contains the TC and IC sample pumps and the DI water loop (DI water reservoir, ion exchange resin column, and the circulation pump).
- **Electronics**—The electronics subsystem includes the six electronic controller and processing boards and a touch panel display. The processing boards include a Data/User Controller (DUC) board, Instrument Controller board (with Ethernet port and two USB ports), Fluidics Controller board, Dual Cell Signal Processor (DCSP) board, and I/O Controller board.

OPTIONAL CONFIGURATIONS

The following optional configuration and accessories (including software) are available for the Sievers M5310 C TOC Analyzers:

Configurations

- Two-Stream Inlet

Accessories (including software)

- Printer
- Mouse
- Sievers Autosampler with Sievers DataPro2[®] Software

Two-Stream Inlet

(On-Line TOC Analyzer Only)

The Sievers Sievers M5310 C On-Line TOC Analyzer is available with a two-stream sample line connection to the Analyzer's *Sample Inlet* port(s). The two-stream inlet option enables efficient sampling of two independent sample sources, without the need to alter the initial inlet setup.

ACCESSORIES

Printer

The Analyzer is designed to work with most USB point-of-service (POS) printers.

The following printers are available as an optional accessory directly from SUEZ.

- **Citizen CD-S500A**
- **Epson TM-U220D**

Mouse

The Analyzer's standard user interface is a touchscreen. You have the option to interact with the Analyzer using a USB mouse supported but not provided by Sievers.

Sievers Autosampler

(Laboratory and Portable TOC Analyzers Only)

The Sievers Autosampler system can be used to automate the analysis of up to a quantity of 120 for 17-mL capacity vials, a quantity of 63 for 30-mL capacity DUCT vials, or a quantity of 63 for 35-mL and 40-mL capacity vials. Results are displayed and stored on your computer via the Sievers DataPro2 Software.

This optional system for high-volume laboratory applications consists of the following:

- Sievers Autosampler
- Sievers DataPro2 Software, running on a your computer with a Windows® Operating Systems [Windows XP (SP2 or higher), Windows 7, Windows 8, Windows 10, Windows Server 2008, or Windows Server 2012]
- Sievers M5310 C Laboratory or Portable TOC Analyzer
- Printer (optional)

Sievers DataPro2 Software

Sievers DataPro2 Software integrates the Sievers Autosampler with the Sievers M5310 C Laboratory or Portable TOC Analyzer, giving you the ability to operate the Sievers Autosampler with up to four Analyzers. The software runs on the following Microsoft operating systems with a familiar Windows interface design:

- Windows XP (SP2 or higher)

- Windows 7
- Windows 8
- Windows 10
- Windows Server 2008
- Windows Server 2012

AUTOMATED USER AND SYSTEM PROTOCOLS

Use the Sievers DataPro2 Software to create automated customer user protocols and summary reports for running sample analyses. The following pre-set protocols are also included in the software:

Calibration

- Single-Point Calibration (1 ppm, 5 ppm, 10 ppm, 25 ppm, 50 ppm)
- Multi-Point Calibration

Municipal Tests

- Single-Point Verification (500 ppb, 1 ppm, 2 ppm, 5 ppm, 10 ppm, 25 ppm, 50 ppm)
- Autoreagent Verification

Validation

- ICR Validation

SECURE DATA

To ensure the integrity of all protocol results, all result files are fixed and cannot be altered. Save the data to a network (or a static media such as DVD or tape archive) to provide the secure environment required by the FDA.

Sievers DataPro2 Software also supports 21 CFR Part 11 TOC Analyzer compliance by providing secure data, audit information, and the ability to save results to a static media. For additional information, refer to *Sievers DataPro2 Software with (Optional) DataGuard User Guide*.

THIS PAGE IS INTENTIONALLY LEFT BLANK.

3

INSTALLATION

OVERVIEW

This chapter provides installation instructions for the Sievers M5310 C TOC Analyzers and applies to ALL models (*On-Line, Laboratory, and Portable*), except where noted.

An interior overview diagram of each Analyzer model is provided in [Chapter 7. "Maintenance."](#)

If you need additional assistance contact Technical Support or your local representative.

INSTALLATION INSTRUCTIONS

Perform the following steps, in the listed order, to install and configure the Analyzer for operation.

STEP 1: UNPACK AND INSPECT THE ANALYZER

Unpack the shipping carton(s) and verify that the shipment contains all the contents shown in the following [Packing List](#) section.

Warning



Shipping boxes containing an Analyzer may weigh over 40 lb—necessitating a two-person lift technique when handling. Such boxes are labeled with this warning, supporting OSHA standards intended to protect employees from injury.

We recommend that our customers use a two-person lift and use this handling technique when lifting items weighing over 40 lb.



NOTE: Save *all* original packing materials! If you need to return the Analyzer now or in the future, you **must** pack it in the **original** carton to ensure that no damage occurs during shipment. Also, always insure the Analyzer in any return shipments.

Packing List

- Sievers M-Series Analyzer
- Power cord (*Laboratory and Portable Analyzers*)
- M-Series TOC Analyzer Quick Start Guide
- *Certificate of Calibration*
- PVC tubing (*On-Line and Portable TOC Analyzers Only*)
- Reagents carton (shipped separately)
- Analyzer Accessories Kit (specific to your Analyzer model):

Sievers Laboratory TOC Analyzer

- Teflon tubing, with fittings
- Plastic waste tubing, 1/8" OD with Swagelok® fitting
- Dispensing bottle
- Filling fixture [two lengths of tubing (one with an elbow fitting) and a T-fitting]
- Individual (loose) elbow fitting
- Resin cartridge
- Reagent holder
- USB

Sievers On-Line and Portable TOC Analyzers

- Teflon tubing with fittings
- Dispensing bottle
- Filling fixture [two lengths of tubing (one with an elbow fitting) and a T-fitting]
- Individual (loose) elbow fitting
- C-flex tubing
- One (or two with *Two-Stream* option) 1/4" PFA tubing sections, each with in-line filter
- Resin cartridge
- Reagent holder (*Portable TOC Analyzers Only*)
- USB

Additional Equipment Requirements

You will also need to provide the following for the installation process:

- Plastic tubing for the waste outlet (3/4" OD / 1/2" ID)
- Ethernet cable (optional for Modbus TCP/IP communications or for data management using Ethernet)

(On-Line TOC Analyzer Only)

- Electrostatic Discharge (ESD) protection
- Conduit connector (strain relief hubs) for power conduit wiring
- Sealing washer for conduit connector
- Ring terminal for AC conduit ground wire, 16-14 American Wire Gauge (AWG)
- Insulated wire for AC power conduit¹ (18-12 AWG), rated to 300 Volts. Strip length should be 8-9 mm (0.33 in.) (Metallic conduit is required for the Analyzer to meet CE marking electrical requirements.)
- External circuit breaker or switch that disconnects both poles of the supply voltage, rated appropriately
- Strain relief hub (conduit connector) and washer for I/O wiring
- Analog (4-20 mA) recorder (optional)
- Wire for 4-20 mA and alarm output (28-16 AWG), rated to 300 Volts

¹. Metallic conduit is required for the Analyzer to meet CE marking electrical requirements.

Chapter 3 INSTALLATION

- Mounting hardware to support the Analyzer — Mounting bolts should support four times the weight of the Analyzer [total = 64.8 kg (142.40 lb)]. For more information, see [“Step 3: Select a Location for the Analyzer.”](#)

(Portable TOC Analyzer Only)

- Analog (4-20 mA) recorder (optional)

Removing the DI Loop Shipping Bracket

Remove the shipping foam inserts from the Analyzer inserted to secure the DI loop during shipping. Leave the bracket in place. Save the foam inserts to re-install in the event of returning the Analyzer to SUEZ for servicing.

STEP 2: COMPLETE THE IDENTIFICATION RECORDS

Complete the Identification Records information on [page 3](#) by recording the Analyzer serial number and the date of installation. The serial number is located outside on the back of *Laboratory and Portable TOC Analyzers*, and on the right side of the *On-Line TOC Analyzer*.

STEP 3: SELECT A LOCATION FOR THE ANALYZER

The enclosure for the On-Line TOC Analyzer is rated IP 45 to withstand the hazards of industrial process environments. The Portable TOC Analyzer is rated IP 21 for incidental exposure to water.

Select a location away from direct sunlight and extreme temperatures. Avoid operating at temperatures greater than 40 °C (104 °F) or lower than 10 °C (50 °F), as temperatures outside this range can prevent proper operation.

In addition to these general instructions, refer to the sections that follow for information pertaining to the specific model of your Analyzer.

Sievers On-Line TOC Analyzer

Sievers On-Line TOC Analyzers are designed to be mounted on a wall or support stand. When selecting the location, mount the Analyzer so that the display screen is approximately at eye-level. For illustrations of required clearances, see [Figure 6](#) and [Figure 7](#). Allow a minimum of 5 cm (2 in.) clearance between the back of the Analyzer and the wall for heat dissipation. Plan for 30.5 cm (12.0 in.) of clearance on the sides, top, and bottom of the Analyzer for the plumbing and electrical connections. This clearance provides the proper circulation for temperature and humidity control.

Provide hardware for mounting the Analyzer on a wall or instrument rack, as hardware should be selected based on site-specific circumstances. Choose mounting bolts to support four times the weight of the unit² [total = 64.8 kg (142.40 lb)].

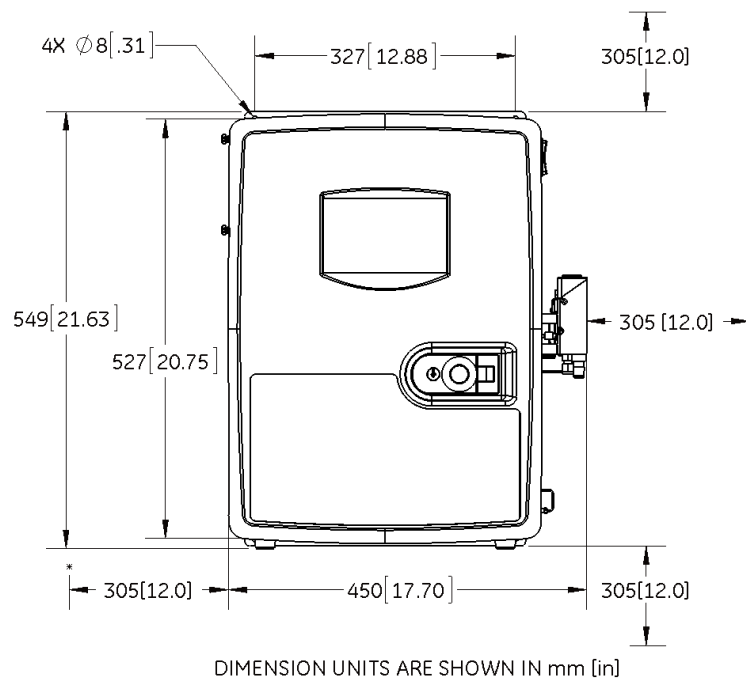

Figure 6: Required Installation Clearances — On-Line TOC Analyzer (Front View)

². 4 x 16.2 kg = 64.8 kg (4 x 35.6 lb = 142.40 lb)

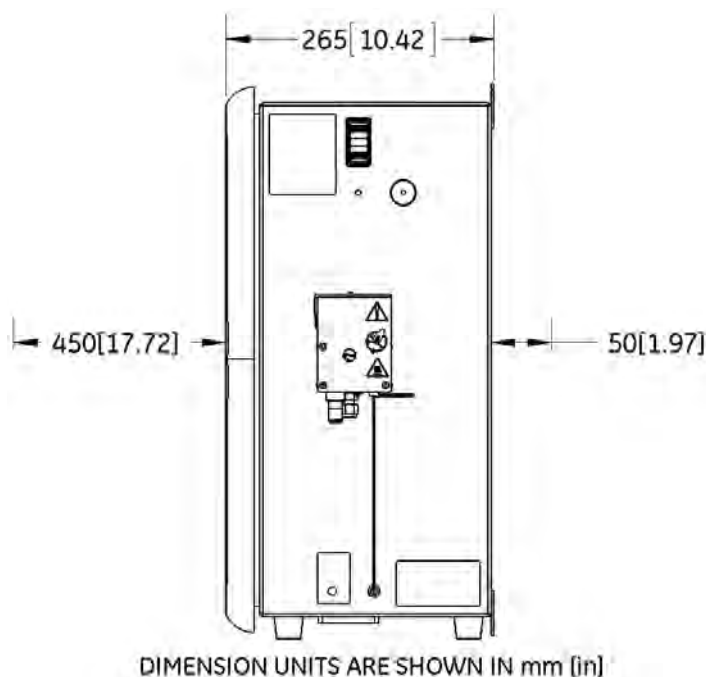

Figure 7: Required Installation Clearances — On-Line TOC Analyzer (Side View)

Sievers Laboratory and Portable TOC Analyzers

The Analyzer is designed to be operated right-side up, resting on the rubber feet. Place the Analyzer on a clean, unobstructed surface that can accommodate the Analyzer's dimensions and weight. For information regarding the specifications for your Analyzer model, refer to the corresponding model section in [Chapter 2, "System Overview."](#) Also, for proper heat dissipation, ensure that 16 cm (6.3 in.) is available at the rear and on both sides of the Analyzer.

SIEVERS AUTOSAMPLER SYSTEM







If using the Analyzer with an Autosampler system, allow approximately 2.5 cm (1 in.) of space between the Sievers Autosampler and Analyzer to ensure the proper functioning of both units. Plan for room to accommodate a computer and (if applicable) a printer near the Analyzer and Autosampler. For additional information, refer to the *Sievers Autosampler Installation Guide*.

STEP 4: INSTALL THE REAGENT CARTRIDGES

The oxidizer and acid reagents are shipped separately from SUEZ in specific packaging for safe transit. Carefully read the attached MSDS sheets prior to opening the packaging. There will be two reagent cartridges inside the packaging, one clearly identified as

“OXIDIZER (15% ammonium persulfate)” and one as “PHOSPHORIC ACID SOLUTION.” After installing these reagent cartridges, record the installation on the *Consumables* tab of the Analyzer’s *Maintenance* screen. Refer to [“To renew an expiration date” on page 185.](#)

The reagent installation procedures in this section are specific to the Analyzer model. Refer to the applicable section for your Analyzer

Know These Safety Warnings	
	Hazardous reagents (ammonium persulfate and phosphoric acid) are used in the Analyzer. Before installing a reagent, read the corresponding Material Safety Data Sheet (MSDS) for proper handling precautions and spill or leak procedures. The MSDS are contained in the pouch located on the outside of the reagent shipping box.
	Installation of reagents and most Analyzer maintenance requires access to the inside of the Analyzer. To avoid potentially dangerous shock—BEFORE opening the Analyzer—first stop any analysis, stop the operating system (using the SHUT DOWN  button in the Analyzer’s firmware) and then turn off power and disconnect from the power supply.
	To avoid exposure to the chemical reagents, wear acid-resistant gloves and safety goggles.
	Reagent cartridges are for single-use only. Do not refill. Any refilling or reusing of reagent cartridges will void all Analyzer parts and warranties and will nullify any performance claims.
	Keep the opaque type reagent cartridge in an upright position before attaching and detaching the reagent supply line to avoid exposure to the chemical reagent. Save the plug to later reinsert it into the nozzle inlet after removing the cartridge from the Analyzer during a cartridge replacement process.

Chapter 3 INSTALLATION



Opaque Reagent Cartridge Type (without Red/Green Button Valve) ***Clear Reagent Cartridge Type (with Red/Green Button Valve)***

Figure 8: Identifying Reagent Cartridge Types



NOTE: There are two types of reagent cartridges for the acid and oxidizer reagents. The **CLEAR CARTRIDGE** type includes a red/green button valve on the inlet nozzle. The other **OPAQUE CARTRIDGE** type does not have a valve, but has a plug with containment tape over the inlet nozzle. The **OPAQUE CARTRIDGE** type also has a vent on the bottom of the cartridge, covered by a yellow sticker with a red tab.

The installation differs as noted in the instructions.

To install the reagent cartridges (Opaque type) — Laboratory and Portable Analyzers

This procedure includes instructions for installing both the *Acid* and *Oxidizer* reagent cartridges of the **Opaque Cartridge** type in a *Sievers Laboratory or Portable TOC Analyzer*. (Refer to [Figure 8: Identifying Reagent Cartridge Types](#) on [page 44](#) to identify. The **OPAQUE TYPE** cartridge does **not** have a red and green valve button valve.)

1. Before opening and working inside the Analyzer (and working with the chemical reagents) ensure that:
 - The Analyzer power switch is Off and the power cord is disconnected. (**Always** stop the operating system first by using the **SHUT DOWN** button on the *Home* screen **before** turning the power switch to **OFF**.)
 - You are wearing the recommended personal protective equipment (PPE), as outlined in the previous Safety Warnings.
2. Open the Analyzer by removing the right side panel. (The panel is attached to the Analyzer by magnets.) Stabilize the Analyzer with one hand on the top panel (*Laboratory TOC Analyzer*) or handle (*Portable TOC Analyzer*). Grasp the edge of the right side panel from the back of the Analyzer. Pull the entire panel away from the Analyzer.
3. Locate and remove the reagent holder. Set it next to the Analyzer for the assembly process. Stand the holder up vertically on its short side with the cut-out end pointed upward and the label facing you.
4. Start with the *Acid* reagent cartridge. Pull the red tab to remove the yellow sticker from the vent on the bottom of the cartridge. Pause briefly to let the air vent.
5. Holding the reagent cartridge with the plugged nozzle inlet facing upward (as directed by the “This end up” label), remove the containment tape from the top of the reagent cartridge inlet nozzle. Next, remove the plug from the nozzle. (SAVE the plug to use in a future replacement process.)
6. Inside the Analyzer, locate the reagent supply line with the label that matches the cartridge being installed. (The reagent supply line for the *Acid* reagent cartridge is labeled *Acid*. The reagent supply line for the *Oxidizer* reagent cartridge is labeled *Oxidizer*.) Attach the reagent supply-line PEEK nut to the inlet at the top of the reagent cartridge and tighten finger tight.
7. Repeat steps [5](#) and [6](#) to connect the *Oxidizer* reagent cartridge.
8. Place the *Acid* reagent cartridge in the back compartment of the reagent holder, ensuring that the nozzle-end of the cartridge is pointed through the cutout portion of the reagent holder and is closest to the bottom.
9. Place the *Oxidizer* reagent cartridge in the front compartment of the reagent holder, ensuring that the nozzle-end of the cartridge is pointed through the cutout portion of the reagent holder and is closest to the bottom.
10. Lift the entire reagent holder (with the *Acid* and *Oxidizer* reagent cartridges in place) and set the holder horizontally onto the reagent holder mount, which is located on the floor of the unit. The magnet feet of the holder fit into the corner grooves on the mount. You should feel the magnets secure the holder into place.

Chapter 3 INSTALLATION

11. Replace the side panel on the Analyzer. Ensure that the magnets have connected and the panel is secure.



NOTE: Record the installation of the reagent cartridges in the Analyzer later as part of [“Step 12: Configure Basic Analyzer Settings” on page 76.](#)

To install the reagent cartridges (*Clear type*) — *Laboratory and Portable Analyzers*

This procedure includes instructions for replacing both the *Acid* and *Oxidizer* cartridge of the **CLEAR** type in a *Sievers Laboratory or Portable TOC Analyzer*. (Refer to [Figure 8: Identifying Reagent Cartridge Types](#) on [page 44](#) to identify.)

1. Before opening and working inside the Analyzer (and working with the chemical reagents) ensure that:
 - The Analyzer power switch is Off and the power cord is disconnected. (**Always** stop the operating system first by using the **SHUT DOWN** button on the *Home* screen **before** turning the power switch to **OFF**.)
 - You are wearing the recommended personal protective equipment (PPE), as outlined in the previous Safety Warnings.
2. Open the Analyzer by removing the right side panel. (The panel is attached to the Analyzer by magnets.) Stabilize the Analyzer with one hand on the top panel (*Laboratory TOC Analyzer*) or handle (*Portable TOC Analyzer*). Grasp the edge of the right side panel from the back of the Analyzer. Pull the entire panel away from the Analyzer.
3. Locate and remove the reagent holder and set it next to the Analyzer for the assembly process. Stand the holder up vertically on its short side with the cut-out end pointed upward and the label facing you.
4. Inside the Analyzer, locate the reagent supply line with the label that matches the cartridge being installed. (The reagent supply line for the *Acid* reagent cartridge is labeled *Acid*. The reagent supply line for the *Oxidizer* reagent cartridge is labeled *Oxidizer*.) Attach the supply-line PEEK nut to the inlet at the top of the reagent cartridge and tighten finger tight.
5. Slide the green button on the nozzle inlet in to open the valve.
6. Repeat steps [4](#) and [5](#) to connect the *Oxidizer* reagent cartridge.
7. Place the *Acid* reagent cartridge in the back compartment of the reagent holder, ensuring that the nozzle-end of the cartridge is pointed through the cutout portion of the reagent holder and is closest to the bottom.
8. Place the *Oxidizer* reagent cartridge in the front compartment of the reagent holder, ensuring that the nozzle-end of the cartridge is pointed through the cutout portion of the reagent holder and is closest to the bottom.

9. Lift the entire reagent holder (with the *Acid* and *Oxidizer* reagent cartridges in place) and set the holder horizontally onto the reagent holder mount, which is located on the floor of the unit. The magnet feet of the holder fit into the corner grooves on the mount. You should feel the magnets secure the holder into place.
10. Replace the side panel on the Analyzer. Ensure that the magnets have connected and the panel is secure.



NOTE: Record the installation of the reagent cartridges in the Analyzer later as part of [“Step 12: Configure Basic Analyzer Settings” on page 76.](#)

To install the reagent cartridges (*Opaque type*) — *On-Line TOC Analyzer*

This procedure includes instructions for installing both the *Acid* and *Oxidizer* reagent cartridges of the *Opaque Cartridge* type in a *Sievers On-Line TOC Analyzer*. (Refer to [Figure 8: Identifying Reagent Cartridge Types](#) on [page 44](#) to identify. The **OPAQUE TYPE** cartridge does **not** have a red and green valve button valve.)

1. Before opening and working inside the Analyzer (and working with the chemical reagents) ensure that:
 - The power switch is Off and the Mains turned Off. (**Always** stop the operating system first by using the **SHUT DOWN** button on the *Home* screen **before** turning the power switch to **OFF**.)
 - You are wearing the recommended personal protective equipment (PPE), as outlined in the previous Safety Warnings.
2. Open the door to the Analyzer. Push the release button and pull the tab to unlatch the door.
3. Loosen the thumbscrews on the reagent housing cover, which is located on the (lower front) floor of the Analyzer. Lift the cover straight up to remove and set it aside during the assembly process.
4. Start with the *Acid* reagent cartridge. Pull the red tab to remove the yellow sticker from the vent on the bottom of the cartridge.
5. Holding the reagent cartridge with the plugged nozzle inlet facing upward (as directed by the “This end up” label), remove the containment tape from the top of reagent cartridge inlet nozzle. Next, remove the plug from the nozzle. (SAVE the plug to use in a future replacement process.)
6. Inside the Analyzer, locate the reagent supply line with the label that matches the cartridge being installed. (The reagent supply line for the *Acid* reagent cartridge is labeled *Acid*. The reagent supply line for the *Oxidizer* reagent

Chapter 3 INSTALLATION

cartridge is labeled *Oxidizer*.) Attach the supply-line PEEK nut to the inlet at the top of the reagent cartridge and tighten finger tight.

7. Repeat steps [5](#) and [6](#) to connect the *Oxidizer* reagent cartridge.
8. Place the *Acid* reagent cartridge into the back compartment of the reagent housing, positioning the cartridge horizontally with the tubing-end facing toward the right and open-side of the housing and the nozzle closest to the bottom.
9. Place the *Oxidizer* reagent cartridge into the front compartment of the reagent holder, positioning the cartridge horizontally with the tubing-end facing toward the right and open-side of the housing and the nozzle closest to the bottom.
10. Carefully lower the reagent housing cover over the reagents, sliding the guide pin (located toward the back and on top of the reagent housing) through the guide hole on the cover.

Also, make sure that the two tubing lines are carefully positioned between the cover and cradle-side cushions of the housing.

11. Tighten the thumbscrews on the reagent housing cover to secure.
12. Close and latch the door to the Analyzer.



NOTE: Record the installation of the reagent cartridges in the Analyzer later as part of [“Step 12: Configure Basic Analyzer Settings” on page 76.](#)

To install the reagent cartridges (*Clear type*) — *On-Line TOC Analyzer*

This procedure includes instructions for installing both the *Acid* or *Oxidizer* reagent cartridges of the *Clear Cartridge* type in a *Sievers On-Line TOC Analyzer*. (Refer to [Figure 8: Identifying Reagent Cartridge Types](#) on [page 44](#) to identify.)

1. Before opening and working inside the Analyzer (and working with the chemical reagents) ensure that:
 - The power switch is Off and the Mains turned Off. (ALWAYS stop the operating system first by using the **SHUT DOWN** button on the *Home* screen BEFORE turning the power switch to **OFF**.)
 - You are wearing the recommended personal protective equipment (PPE), as outlined in the previous Safety Warnings.
2. Open the door to the Analyzer. Push the release button and pull the tab to unlatch the door.
3. Loosen the thumbscrews on the reagent housing cover, which is located on the (lower front) floor of the Analyzer. Lift the cover straight up to remove and set it aside during the assembly process.

4. Inside the Analyzer, locate the reagent supply line with the label that matches the cartridge being installed. (The reagent supply line for the *Acid* reagent cartridge is labeled *Acid*. The reagent supply line for the *Oxidizer* reagent cartridge is labeled *Oxidizer*.) Attach the supply-line PEEK nut to the inlet at the top of the reagent cartridge and tighten finger tight.
5. Slide the green button on the nozzle inlet in to open the valve.
6. Repeat steps [4](#) and [5](#) to connect the Oxidizer reagent cartridge.
7. Place the *Acid* reagent cartridge into the back compartment of the reagent housing, positioning the cartridge horizontally with the tubing-end facing toward the right and open-side of the housing and the nozzle closest to the bottom.
8. Place the *Oxidizer* reagent cartridge into the front compartment of the reagent holder, positioning the cartridge horizontally with the tubing-end facing toward the right and open-side of the housing and the nozzle closest to the bottom.
9. Carefully lower the reagent housing cover over the reagents, sliding the guide pin (located toward the back and on top of the reagent housing) through the guide hole on the cover.

Also, make sure that the two tubing lines are carefully positioned between the cover and cradle-side cushions of the housing.
10. Tighten the thumbscrews on the reagent housing cover to secure.
11. Close and latch the door to the Analyzer.



NOTE: Record the installation of the reagent cartridges in the Analyzer later as part of [“Step 12: Configure Basic Analyzer Settings” on page 76](#).

STEP 5: INSTALL THE DI WATER SYSTEM

The Analyzer is shipped with its DI water reservoir empty and the resin cartridge is shipped separately inside the Analyzer’s Accessories Kit. Fill the DI water reservoir with low-TOC DI water and install the resin cartridge. Prime the DI pump later in [" To prime the DI Water pump" on page 65](#) of this installation process.



NOTE: Each port (*Prime, Run, and DI Pump Outlet*) has a metal latch to use when detaching a fitting ([Figure 9](#)). Press the latch with your finger to release a fitting and close the valve. When inserting or detaching the resin cartridge, insert or detach both end-fittings simultaneously to avoid damaging movement to the cartridge.



Figure 9: Metal Port Latches

To fill the DI water reservoir

1. Before working inside the Analyzer, ensure that the Power switch is off and the power cord is disconnected (*Laboratory and Portable TOC Analyzers*), or the Mains turned **OFF** (*On-Line TOC Analyzer*).

(**Always** shut down the system in the firmware before pressing the power switch to **OFF**.)

2. Locate the following in the Analyzer's Accessories Kit:
 - Dispensing bottle
 - Filling fixture [two lengths of tubing (one with an elbow fitting) and a T-fitting]

Have a paper towel nearby, in case of any leakage during the installation process.

3. Assemble the filling fixture by connecting the two lengths of tubing from the Accessories Kit together using the T-fitting. Attach the remaining open end of the tubing to the nozzle on the dispensing bottle. See [Figure 10](#).



Figure 10: Assembled Filling Fixture

4. Unscrew the lid of the dispensing bottle (leaving the filling fixture attached to the top of the lid), and fill the bottle with this DI water. Replace and tighten the lid to secure it.

5. Insert the elbow-fitting end of the filling fixture into the *Prime* outlet ([Figure 11](#)).

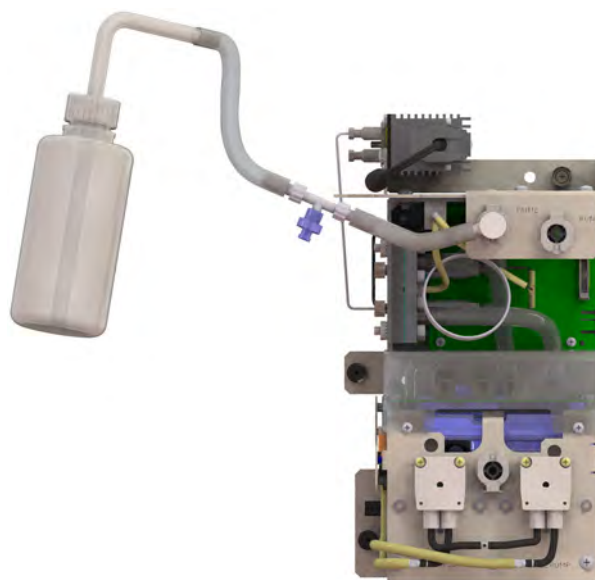

Figure 11: Filling the DI Water Reservoir

6. Squeeze the bottle to fill the DI reservoir until the water line reaches JUST BELOW the top of the reservoir. Use the float seen through the window as a guide, as shown in [Figure 12](#).

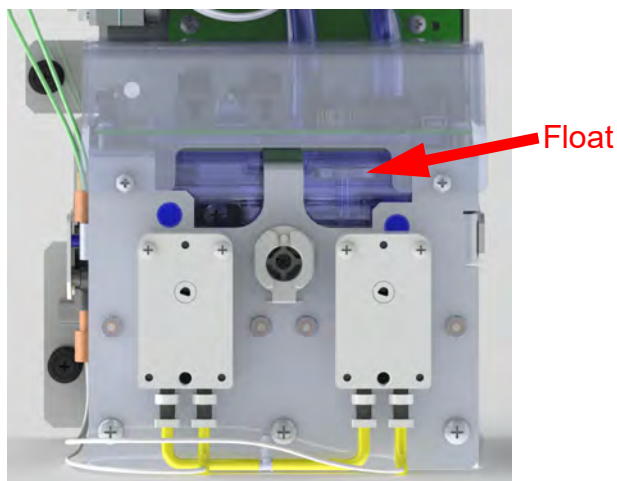

Figure 12: DI Reservoir Level with Float



NOTE: It is important to only fill the reservoir to the suggested level. Otherwise, the water in the viewable portion of the reservoir may overflow to another level in the reservoir (which is not viewable from the window). If you do overfill the reservoir, drain the excess water by following the troubleshooting procedure, [“To drain excess water from the DI water reservoir” on page 198.](#)

Chapter 3 INSTALLATION

7. Press the latch of the *DI pump* outlet up to release the dispensing bottle's elbow-fitting for removal of the dispensing bottle accessory.
8. Proceed to the next section to install the resin cartridge.

To install the resin cartridge

Install the resin cartridge into the *Prime* position to prepare for priming the DI pump later in the installation process in [“Step 8: Prime the DI Pump” on page 65](#).

1. Ensure that the DI water reservoir is filled, according to the previous instruction.
2. Install the resin cartridge. Simultaneously, insert one elbow-fitting end of the cartridge into the *Prime* port and the other elbow-fitting end into the DI pump outlet.

Verify that the ends are secure before moving to the next step.



NOTE: The DI pump outlet is located between the IC and TC sample pumps, as shown in [Figure 13: Resin Cartridge — Position for Priming](#).

3. You will prime the DI pump in a later step after installing I/O control wiring (optional) and power.

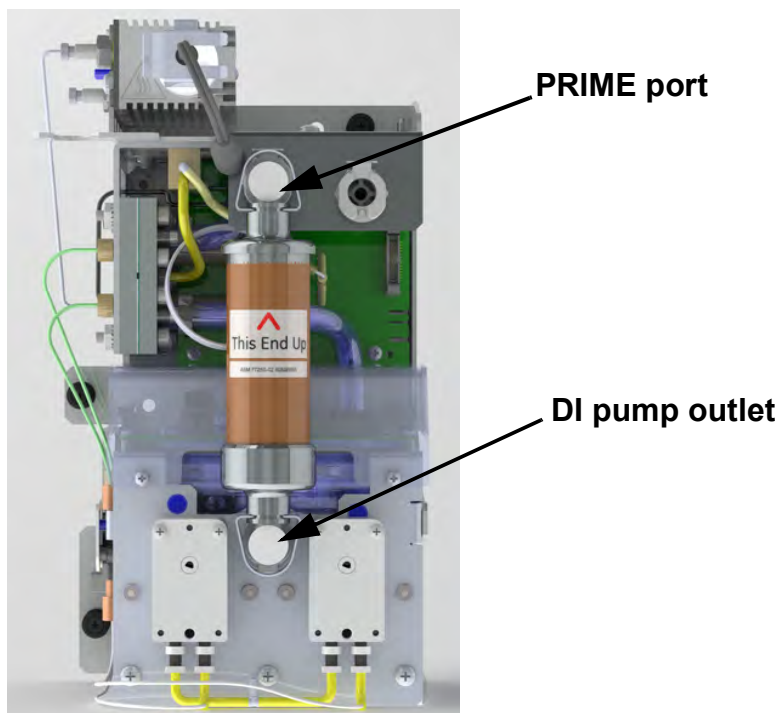



Figure 13: Resin Cartridge — Position for Priming

STEP 6: INSTALL I/O CONTROL WIRING (OPTIONAL)

(On-Line and Portable TOC Analyzers Only)

Warning	
	<p>The output and alarm connections should be installed by a qualified electrician. Ensure that ESD protection is worn during installation of any wiring inside the Analyzer.</p>

This section includes:

- [Working with the Terminal Blocks](#)
- [Wiring 4-20 mA and Alarm Outputs](#)
- [Working with Pinout Tables and Wiring Diagrams](#)
- [Wiring the Remote Start \(Binary Input\)](#)

Working with the Terminal Blocks

The J4, J5, and J6 terminal blocks contain the following:

- **(J4) Serial and 4-20 mA Outputs 1-3** — Use these outputs to record Analyzer data. The analog output is calibrated at the factory prior to shipping. Each output has a voltage isolation level of 500 V and is individually isolated. The maximum 4-20 mA load is 600 ohms.
- **(J5) Binary Input** — Use these connections to execute “Start Analysis” and “Stop Analysis” commands to the Analyzer from a remote location, such as a Programmable Logic Controller (PLC).
- **(J6) Alarm Output 1-4** — Use these outlets for alarm outputs. Each output has a power isolation level of 500 V and is individually isolated. The maximum load for the alarm ports is 30 VDC at 1.0 A or 125 VAC at 0.5 A.

Wiring 4-20 mA and Alarm Outputs

Refer to the appropriate step-by-step instruction procedures that follow, corresponding to your Analyzer model: *On-Line TOC Analyzer* or *Portable TOC Analyzer*.

Chapter 3 INSTALLATION

To install 4-20 mA and alarm outputs — *On-Line TOC Analyzer*

Use this instruction to install 4-20 mA and alarm output connections on the I/O board inside the On-Line TOC Analyzer.

Provide a small flat-blade screwdriver and wire to complete this procedure. The wire should be 28-16 AWG, rated to 300 Volts. The strip length for each pin should be 8-9 mm (0.33 in).

1. Before working with any of the Analyzer's inside components, exercise ESD protection.
2. To access the I/O board, open the door to the Analyzer (push the release button and pull the tab to unlatch). Remove the enclosure cover located on the back of the door by using a Phillips-head (crosshead) screwdriver #2 to loosen the two captive screws securing the cover. The I/O board is located behind the inside panel of the Analyzer's door and the board is mounted in the lower-left area of the door.
3. On the left side-panel, remove the cap from the bottom pass-through cut-out. Squeeze the conical side of the cap and push it out of the Analyzer.
4. Route the cables to the terminal block through this pass-through port. Terminal block J4 is designated for 4-20 mA outputs and terminal block J6 is for the alarm outputs.

To install the wires in a terminal block, first remove it from the I/O board. Note the orientation of the terminal block before removing it and firmly grasp the terminal block. Pull it straight out from the terminal header on the board.

5. Identify the correct pin position for each wire you are installing according to Tables [1](#) and [2](#).
6. Use a small, flat-blade screwdriver to completely loosen the screw for that pin. (The screws are located underneath the terminal block.) Insert the wire into the clamp for the pin (located on the side of the terminal block) and tighten the pin screw to secure the wire.
7. Repeat steps [5](#) and [6](#) for each pin you will be using.
8. Gently pull on each connection to make sure the connection is secure.
9. Plug the terminal block into the terminal header on the I/O board.
10. Repeat steps [4](#) through [9](#) for each terminal block, as needed.

To install 4-20 mA and alarm outputs — *Portable TOC Analyzer*

Provide a small flat-blade screwdriver, a #2 Phillips-head (crosshead) screwdriver, and wire to complete this procedure. The wire should be 28-16 AWG, rated to 300 Volts. The strip length for each pin should be 8-9 mm (0.33 in).

1. To access the I/O board, detach the protective cover from the rear of the Analyzer by removing the two Phillips-head (crosshead) screws.

The I/O board is mounted perpendicular to the back of the Analyzer, and the terminal blocks extend outside the Analyzer through cutouts in the housing. These terminal blocks are accessible from the back of the Analyzer and are labeled “Alarms,” “Binary,” and “4-20 mA.”
2. To install the wires in a terminal block, first pull out the terminal block for ease in the installation process. Note the orientation of the terminal block before removing it. Firmly grasp the terminal block and pull it straight out from the terminal header on the board.
3. Identify the correct pin location for each wire you are installing according to Tables [1](#) and [2](#).
4. Use a small flat-blade screwdriver to completely loosen the screw for that pin. The screws are located underneath the terminal block. Insert the wire into the clamp for the pin (located on the side of the terminal block) and tighten the pin screw to secure the wire.
5. Repeat steps [3](#) and [4](#) for each pin you will be using.
6. Gently pull on each connection to make sure the connection is secure.
7. Plug the terminal block into the terminal header on the I/O board.
8. Repeat steps [2](#) through [7](#) for each terminal block, as needed.
9. Replace the Analyzer’s enclosure panel, making sure that the magnets are secured.

Working with Pinout Tables and Wiring Diagrams

Reference the following information, as needed, when wiring 4-20 mA outputs and alarms.

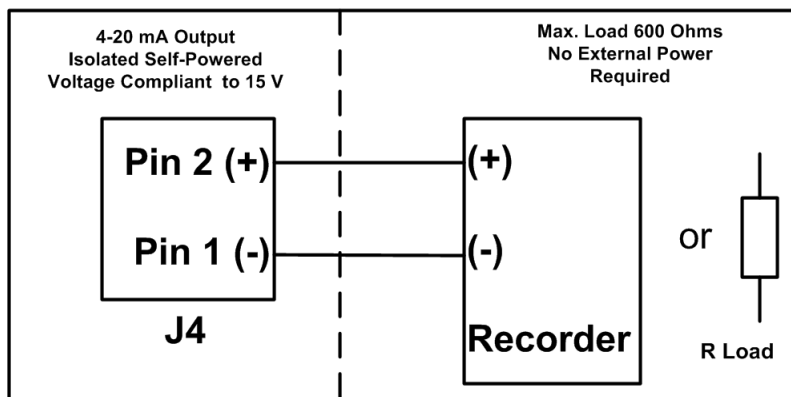

Figure 14: Wiring 4-20 mA Connections

Chapter 3 INSTALLATION

J4 TERMINAL WIRING

The *4-20 mA analog outputs* are isolated from system ground. The 4-20 mA outputs are also individually isolated from each other, and therefore may be connected to multiple industrial control systems (ICS) with differences in ground potential.

TABLE 1: SERIAL AND 4-20 MA OUTPUTS (J4)

Pin Number	Output
1	#1 4-20 mA (Return) -
2	#1 4-20 mA (Out) +
3	#2 4-20 mA (Return) -
4	#2 4-20 mA (Out) +
5	#3 4-20 mA (Return) -
6	#3 4-20 mA (Out) +

J6 TERMINAL WIRING

The *alarm outputs* are isolated from system ground and from each other. You can configure each of the alarm outputs.

The *outputs* are implemented by relays, which are intended for low voltage use only. The load switched by the relays should be resistive and should be limited to 1 Amp maximum and 30 Volts DC maximum.

TABLE 2: ALARM OUTPUTS (J6)

Pin Number	Outputs
1	Alarm 1 (Common) output
2	Alarm 1 (NC*) output
3	Alarm 1 (NO*) output
4	Alarm 2 (Common) output
5	Alarm 2 (NC*) output
6	Alarm 2 (NO*) output
7	Alarm 3 (Common) output
8	Alarm 3 (NC*) output
9	Alarm 3 (NO*) output
10	Alarm 4 (Common) output
11	Alarm 4 (NC*) output
12	Alarm 4 (NO*) output

* NC = normally closed, NO = normally open

Wiring the Remote Start (Binary Input)

The remote start (binary input) connection is intended to execute “Start Analysis” and “Stop Analysis” commands to the Analyzer from a remote location, such as a PLC.

J5 TERMINAL WIRING

The J5 terminal block is used for the binary input. For the pin references, refer to ["Figure 15: Wiring Option for Binary Input — Using Analyzer’s Internal Supply" on page 58.](#)

The *binary start/stop analysis input* is isolated from system ground. You can configure the polarity of operation.

The *+ input* should be supplied with a voltage from +11 volts to +24 volts and the *-input* should be controlled by a relay or an open collector transistor.

Chapter 3 INSTALLATION

TABLE 3: BINARY INPUTS (TERMINAL BLOCKJ5)

Pin Number	Output
1	+24 V
2	In+
3	In-
4	GND



NOTE: The +24 volts (0.5 A max) and system ground are provided for local use only and are not intended for connections more than 4.5 meters (15 ft) away from the Analyzer.

To install the binary input connections

You can wire the binary input connection in a variety of ways, such as the examples shown in [Figure 15: Wiring Option for Binary Input — Using Analyzer's Internal Supply](#) and [Figure 16: Wiring Option for Binary Input — Using External Supply](#).

Before using the binary input connection, you must activate the *Binary Input* feature in the Analyzer firmware. You will do this later during the installation process in [“Step 12: Configure Basic Analyzer Settings” on page 76](#).



NOTE: Make sure to confirm the correct signal strength before setting the *Binary Input* to **ON** in order to avoid unexpectedly starting or stopping analysis.

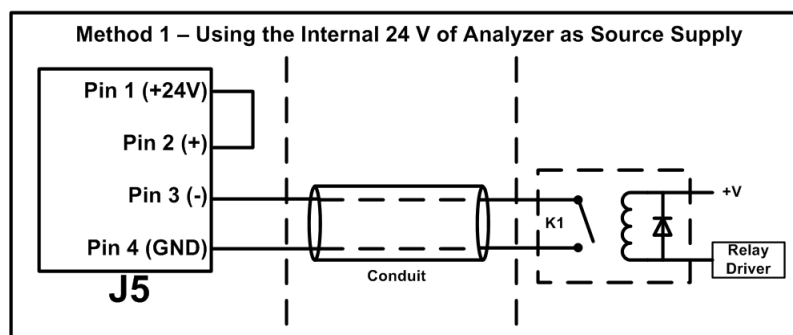

Figure 15: Wiring Option for Binary Input — Using Analyzer's Internal Supply

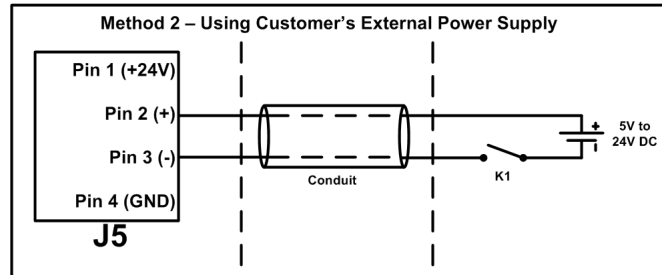

Figure 16: Wiring Option for Binary Input — Using External Supply

To install the binary input connections — *On-Line TOC Analyzer*

Use this instruction to install the binary input connections on the I/O board inside the On-Line TOC Analyzer.

You will need a small flat-blade screwdriver and wire to complete this procedure. The wire should be 28-16 AWG, rated to 300 Volts. The strip length for each pin should be 8-9 mm (0.33 in).

1. To access the I/O board, open the door to the Analyzer (push the release button and pull the tab to unlatch). Remove the enclosure cover located on the back of the door by using a Phillips-head (crosshead) screwdriver #2 to loosen the two captive screws securing the cover. The I/O board is located behind the inside panel of the Analyzer's door, and the board is mounted in the lower-left area of the door.
2. On the right side-panel, remove the cap from the pass-through cut-out (labeled "AC POWER IN"). Squeeze the conical side of the cap and push it out of the Analyzer.
3. Route the cables to the terminal block through this pass-through port. Terminal block J5 is designated for binary inputs.

To install the wires in a terminal block, first remove it from the I/O board. Note the orientation of the terminal block before removing it and firmly grasp the terminal block. Pull it straight out from the terminal header on the board.

4. Identify the correct pin position for each wire you are installing according to Table 3.
5. Use a small, flat-blade screwdriver to completely loosen the screw for that pin. (The screws are located underneath the terminal block.) Insert the wire into the clamp for the pin (located on the side of the terminal block) and tighten the pin screw to secure the wire.
6. Repeat steps 4 and 5 for each pin you will be using.
7. Gently pull on each connection to make sure the connection is secure.
8. Plug the terminal block into the terminal header on the I/O board.

Chapter 3 INSTALLATION

To install the binary input connections — *Portable TOC Analyzer*

You will need a small flat-blade screwdriver, a #2 Phillips-head (crosshead) screwdriver, and wire to complete this procedure. The wire should be 28-16 AWG, rated to 300 Volts. The strip length for each pin should be 8-9 mm (0.33 in).

1. Before working with any of the Analyzer's inside components, ensure that you are exercising ESD protection.
2. To access the I/O board, detach the protective cover from the rear of the Analyzer by removing the two Phillips-head (crosshead) screws.

The I/O board is mounted perpendicular to the back of the Analyzer, and the terminal blocks extend outside the Analyzer through cutouts in the housing. The "Binary" terminal block is accessible from the back of the Analyzer.

3. To install the wires in the terminal block, first pull out the terminal block for ease in the installation process. Note the orientation of the terminal block before removing it and firmly grasp the terminal block. Pull it straight out from the terminal header on the board.
4. Identify the correct pin location for each wire you are installing according to Tables Table [3](#).
5. Use a small flat-blade screwdriver to completely loosen the screw for that pin. The screws are located underneath the terminal block. Insert the wire into the clamp for the pin (located on the side of the terminal block). Tighten the pin screw to secure the wire.
6. Repeat steps [4](#) and [5](#) for each pin you will be using.
7. Gently pull on each connection to make sure the connection is secure.
8. Plug the terminal block into the terminal header on the I/O board.
9. Replace the Analyzer's enclosure panel, making sure that the magnets are secured.

STEP 7: INSTALL POWER

This section contains information about how to install power to the Analyzer. Both the *Laboratory and Portable TOC Analyzers* come supplied with power cords. The On-Line TOC Analyzer requires the installation of conduit to provide an external source of AC power, which is connected to the enclosure using a water-tight conduit connector. This type of electrical connection should be performed by a qualified electrician.

Warning	
	<p>To avoid damaging the DI pump, do not turn the Analyzer to ON without first ensuring that the DI water reservoir is filled, as described in Step 5: Install the DI Water System.</p>

Installing the Power Source

Instructions for connecting to a power source follow. Proceed to the section that applies to your specific model of Analyzer:

- **Laboratory and Portable Analyzers** — [“Power Cord Installation” on page 61](#).
- **On-Line Analyzers** — [“Conduit Installation.”](#)

Additionally, guidelines for [“Powering On and Off the Analyzer”](#) are on [page 64](#).

POWER CORD INSTALLATION

(Laboratory and Portable TOC Analyzers Only)

The *Sievers M5310 C Laboratory and Portable TOC Analyzers* come supplied with power cords. Attach the connector end of the power cord into the connection labeled “Power” on the Analyzer and insert the plug end into a grounded power source. Make sure the cord is seated securely at both ends.

Warning



The Analyzer requires an A/C mains supply of 100-240 volts, and requires the correct power cord for safe operation. Use ONLY the power cord supplied in the Analyzer's Accessory Kit with the Analyzer, which meets this A/C mains supply requirement.

CONDUIT INSTALLATION

(On-Line TOC Analyzer Only)

The *Sievers M5310 C On-Line TOC Analyzer* requires the installation of an external source of AC power connected to the enclosure using a water-tight conduit connector. The electrical connection MUST be performed by a qualified electrician. SUEZ recommends an external switch or circuit breaker to facilitate maintenance and servicing of the Analyzer. Install it near the Analyzer and clearly mark it as the disconnecting device for the Analyzer.

Warning



Electrical conduit should be installed by a qualified electrician. Also, before installing any wiring inside the Analyzer, make sure to wear ESD protection.

To wire the AC conduit

You will need to provide the following:

- Insulated wire for AC power conduit (18-12 AWG), rated to 300 Volts. Strip length should be 8-9 mm (0.33 in.).
- Metallic AC power conduit³ (optional)
- Strain relief hub (conduit connector) and washer
- Terminal ring for AC conduit ground wire, 16-14 AWG
- External circuit breaker or switch that disconnects both poles of the supply voltage, rated appropriately (recommended)

3. Metallic conduit is required for the Analyzer to meet CE marking electrical requirements.

1. Push the release button to unlatch and open the door to the Analyzer.
2. Remove the electrical enclosure cover at the top of the Analyzer by using a Phillips-head (crosshead) screwdriver #2 to loosen the two captive screws securing the cover.
3. Remove the cap from the pass-through port located on the right side-panel of the Analyzer. Squeeze the conical side of the cap and push it outside of the Analyzer.
4. Route the AC power conduit⁴ through this same pass-through port, and secure a strain relief hub (conduit connector) and washer to the conduit and Analyzer bulkhead.
5. Connect the conduit *Line* (brown or black wire) to the bottom of the Terminal block in the left port, and connect the *Neutral* (blue or white wire) in the right port ([Figure 17](#)).

When connecting the wire to the terminal block, loosen the screws on the front of the block and insert the wires as designated. Tighten the screws to secure the wires.

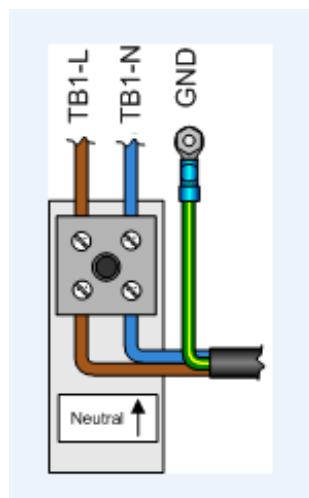



Figure 17: Wiring AC Power Conduit

6. After connecting the wires, pull on each connection gently to make sure the connection is secure.
7. Attach a terminal ring to the grounding conductor (green OR green/yellow wire), and connect it to the ground stud ([Figure 17](#)).
8. Replace the electrical enclosure cover at the top of the Analyzer, and using a Phillips-head (crosshead) screwdriver #2 to tighten the two captive screws for securing the cover.
9. Close and latch the door to the Analyzer.

⁴. Metallic conduit is required for the Analyzer to meet CE marking electrical requirements.

Chapter 3 INSTALLATION

Powering On and Off the Analyzer

Each Analyzer model (*On-Line*, *Laboratory*, and *Portable*) has an **ON/OFF** power switch located on the outside of the Analyzer.⁵ However, before switching the power switch to **OFF**, FIRST press the **SHUT DOWN**  button on the Analyzer's *Home* screen to avoid damaging the Analyzer's operating system. Next, switch the physical power switch (located on the outside of the Analyzer) to **OFF** to complete the power-down cycle.



When performing maintenance inside the Analyzer, SUEZ also recommends disconnecting the power cord from the A/C outlet (*Laboratory and Portable TOC Analyzers*) or shut down the Mains power supply (*On-Line TOC Analyzer*).

Warning	
	To avoid injury and to ensure accurate analysis results, ensure that the Analyzer door (<i>On-Line TOC Analyzer</i>) is closed and latched or side panels (<i>Laboratory and Portable TOC Analyzers</i>) are on and in place during normal operation.

To power on the Analyzer

Press the power switch to **ON** to initiate power in the Analyzer. The firmware screen illuminates for immediate operation.

To power off the Analyzer

1. On the *Home*  screen, press the **SHUT DOWN** button  located in the lower-right portion of the screen. The *Shutdown System* dialog box appears.

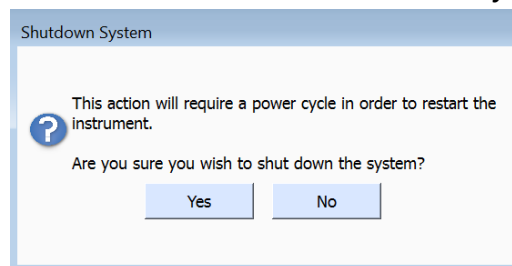

2. Press **YES** to confirm. The system will automatically shut down and the screen will darken (go blank).
3. Locate the power switch on the outside of the Analyzer, and press the power switch to **OFF** to complete the power-down cycle.

⁵. A power **ON/OFF** switch is located on the back of the *Laboratory and Portable TOC Analyzers* and on the right side of the *On-Line TOC Analyzer*.



NOTE: The power cycle is **not** complete until you have pressed the power switch to **OFF**. This ensures that power to ALL circuit boards is disconnected.

4. If planning to perform maintenance inside the Analyzer, disconnect the Analyzer's power cord from the A/C outlet (*Laboratory and Portable TOC Analyzers*) or shut down the Mains power supply (*On-Line TOC Analyzer*).

Warning



In order to avoid the possibility of corrupting the Analyzer's operating system, always **FIRST** shut down system operations on the Analyzer's *Home* screen before pushing the Analyzer's power switch to the **OFF** position.

STEP 8: PRIME THE DI PUMP

With power now installed to the Analyzer, prime the DI pump. This process helps to properly clear the DI loop of air bubbles and saturate the resin cartridge. The priming process takes 180 minutes, plus minimal setup and reset time.

(Optional) Subsequent steps in the installation process can be performed during the 180 minutes time frame for the DI pump to circulate water in the DI loop.

To prime the DI Water pump

1. Ensure that the resin cartridge is set in place with the top valve securely connected in the *Prime* position, according to the instructions performed previously in [“Step 5: Install the DI Water System” on page 49](#).
2. Plug in the Analyzer's power cord (*Laboratory and Portable TOC Analyzers*) or turn on the Mains (*On-Line TOC Analyzer*).
3. Press the Analyzer's power switch to the **ON** position, and let the Analyzer run 180 minutes to allow the DI pump to circulate water in the DI loop.

Chapter 3 INSTALLATION

- After 180 minutes, on the *Home* screen, press the **SHUT DOWN** button  located in the lower-right portion of the screen. The *Shutdown System* dialog box appears.

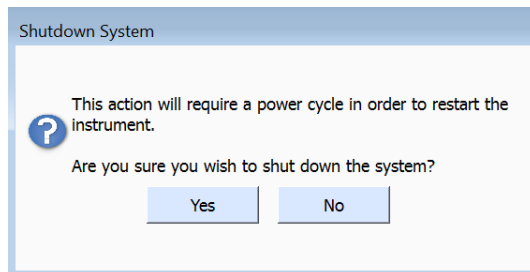

- Press **YES** to confirm.
- Turn the power switch to the **OFF** position.
- View the reservoir water level and verify that the water level reaches **JUST BELOW** the top of the reservoir, as shown in [Figure 18](#).

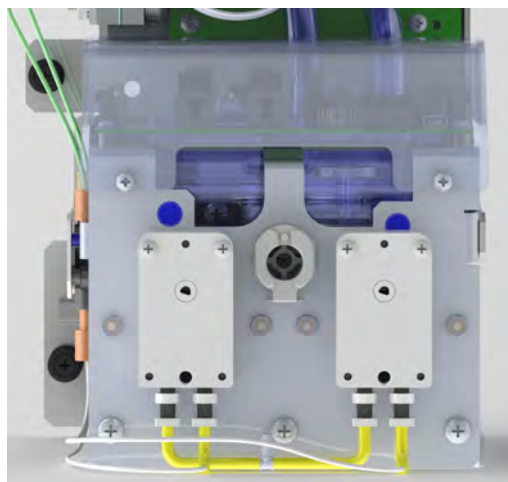

Figure 18: Viewing the Reservoir Water Level

- The water level may now be lower as water will circulate in the DI loop and saturate the resin cartridge during the priming process. Fill the DI reservoir with water if needed, repeating the procedure [“To fill the DI water reservoir” on page 50](#). There is no need to prime the DI pump again.
- After verifying that the water level has stabilized to **JUST BELOW** the top of the reservoir, remove the top valve of the resin cartridge from the prime position. While holding the DI cartridge, simultaneously press the latches on the *Prime* port and the *DI Pump Outlet* port to eject the cartridge.
- Install the resin cartridge into the *Run* position. Insert the elbow-fitting ends of the cartridge into the *Run* port and the *DI Pump Outlet* port. Hold the cartridge tightly in place.

Verify that the ends are secure before moving to the next step.

11. Close and latch the Analyzer's door (*On-Line TOC Analyzer*) or replace the panel (*Laboratory and Portable TOC Analyzers Only*).

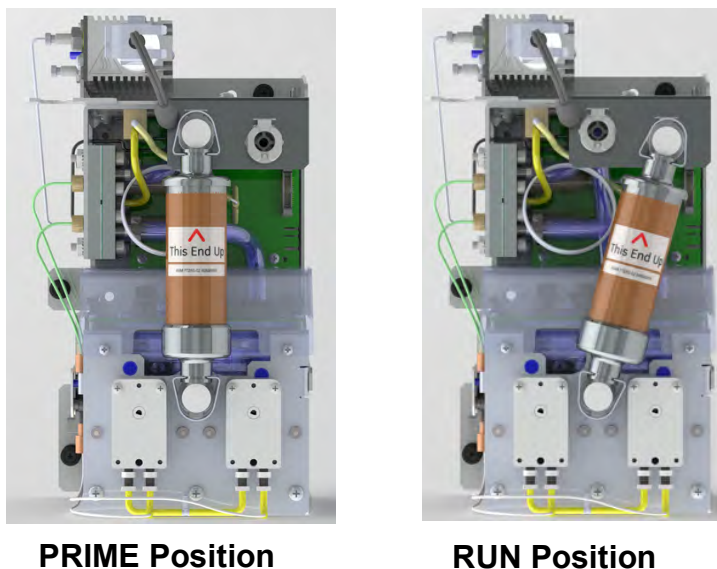

Figure 19: DI Reservoir Cartridge — “Prime” and “Run” Positions

STEP 9: INSTALL ETHERNET AND EXTERNAL DEVICES

This step includes guidance for installing an Ethernet connection. Additionally, you can install a printer or USB connection now.



NOTE: An Ethernet connection allows the user to export historical data from the Analyzer to the computer, computer network, or PLC.

Specific instructions for the following are included in this section:

- Installing an Ethernet connection
- Installing a Printer
- Installing USB connections, including:
 - One Device Port (USB type B) — *Used only for connecting a computer when operating with Sievers DataPro2 Software.*
 - Two Host Ports (USB type A) — *Used for connecting a Sievers Autosampler, printer, mouse, or portable USB memory drive.*

Installing an Ethernet Connection

The Analyzer supports communication to industrial control systems that support the Modbus TCP/IP protocol over the Analyzer's Ethernet port. For more information on Modbus TCP/IP communications, refer to [“The Security Screen” on page 142](#) and [Appendix C, “Working with Modbus.”](#)

This section describes installing the Ethernet connection. You will then need to activate the Ethernet connection in the Analyzer's firmware later in [“Step 12: Configure Basic Analyzer Settings.”](#) You may need more assistance from your network administrator or Information Technology (IT) professional to configure the Modbus communications protocol when connecting to a PLC.



NOTE: You can alternately export data directly to a computer using a USB memory drive. Refer to [“Installing a USB Connection” on page 68](#) for additional information.

To install the Ethernet Connection

Provide either a cross-over Ethernet cable (for connecting directly to a computer) or a straight-through Ethernet cable (for connecting to a network).

1. Attach one end of the Ethernet cable to the *Ethernet* port on the Analyzer and attach the other end of the cable either to an Ethernet port on a network or a computer.
2. You will activate the Ethernet connection and Modbus in [“Step 12: Configure Basic Analyzer Settings”](#) as described in the section, [“To configure the Ethernet output” on page 80](#).



NOTE: The USB ports on the Analyzer are **not** intended for Ethernet connectivity, and cannot not be used with an Ethernet to USB adapter. For acceptable uses of the USB ports, refer to the section [“Installing a USB Connection” on page 68](#).

Installing a USB Connection

Sievers On-Line and Portable TOC Analyzers contain one *device* port labeled “USB COMPUTER,” and two *host* ports labeled “USB HOST.” All USB ports are located on the left side of the *On-Line TOC Analyzer* and on the back of the *Portable TOC Analyzer*.

The Sievers Laboratory TOC Analyzer contains one *device* port labeled “USB COMPUTER” and two *host* ports labeled “USB HOST” on the back of the Analyzer, as well as one additional USB *host* port (Unlabeled) on the front of the Analyzer.

USB DEVICE PORT

The Analyzer has one USB device port labeled “USB COMPUTER”) for connecting the Analyzer directly to a computer, when using the optional Sievers DataPro2 Software to control the Analyzer and the Sievers Autosampler. The USB device port is shaped for a rounded -corner, square connector in contrast to the typical (flat) USB host connector. A *USB-device to USB-host* cable is included in the Sievers Autosampler Accessories Kit.



NOTE: *The USB Device port is intended solely for connecting the Analyzer to the computer for operation with the Sievers DataPro2 Software. It is not possible to export data to a computer through this USB Device port without the use of the Sievers DataPro2 Software.*

To install a USB connection — Device Port (*Optional*)

Install this USB connection in [“Step 14: Install a Sievers Autosampler” on page 89](#) and not at this time. Reference instructions included in *Sievers Autosampler Installation Guide*. Do **not** install the USB connection from the Sievers Autosampler to a computer at this time, as it is imperative to perform this step according to the specific order outlined in the Sievers Autosampler and Sievers DataPro2 Software installations.

USB HOST PORTS

The *On-Line and Portable TOC Analyzers* have two USB host ports (labeled “USB HOST”). These USB host ports are located on the right side of the *On-Line TOC Analyzer* and on the back of the *Portable TOC Analyzer*. The (*Laboratory TOC Analyzer*) also contains two USB host ports (labeled “USB”) on the back of the Analyzer, as well as one additional USB host port (unlabeled) on the front of the Analyzer.

The USB host ports are designed for use with the following peripheral accessories:

- **Printer**
- **Portable USB memory drive**
- **USB Mouse**
- **Sievers Autosampler**

To install a USB Host port connection — Printer (*Optional*)

Refer to the section, [“Installing a Printer” on page 70](#), for step-by-step instructions.

To install a USB Host port connection — Mouse (*Optional*)

To interact with the Analyzer using a USB mouse instead of the touchscreen, you can use any of the USB Host ports on the Analyzer. Insert the USB cable for a

Chapter 3 INSTALLATION

wired mouse or the USB receiver for a wireless mouse into a Host port and follow the step-by-step instructions for [“Set Up the USB Mouse \(Optional\)” on page 81](#).

To install a USB Host port connection — Portable USB memory drive

You can export data from the Analyzer to a portable USB memory drive using any of the USB Host ports on the Analyzer. Insert the USB memory drive into a Host port and follow the step-by-step instructions for exporting data history included in [“To view data history” on page 141](#).

To install a USB Host port connection — Sievers Autosampler (Optional)

Do **not** install the USB connection from the Analyzer to the Sievers Autosampler at this time. You will install this USB connection in [“Step 14: Install a Sievers Autosampler” on page 89](#), and reference instructions included in *Sievers Autosampler Installation Guide*.

Installing a Printer

The Analyzer is designed to work with most USB point-of-service (POS) printers.

The following printers are available as an optional accessory directly from SUEZ.

- Citizen CD-S500A
- Epson TM-722OD

To install a USB printer

1. Connect the USB host connector-end of the printer cable into one of the USB host ports (labeled “USB”) on the Analyzer.
2. Connect the other end of the cable into the printer USB device port.
3. Consult the instructions that come with the printer for additional help, as needed.
4. You will enable and test the printer in the Analyzer later in the installation process in [“Step 12: Configure Basic Analyzer Settings.”](#)

STEP 10: INSTALL THE IOS SYSTEM

(On-Line and Portable TOC Analyzers Only)



NOTE: If you are using a Sievers Autosampler with a Laboratory or Portable TOC Analyzer model, **Do not** proceed with this section. Instead, refer to the Sievers Autosampler User Guide. The information for connecting the sample tubing to the Sample Inlet port is located in the section, “Route the Sample Tubing.”

Plumb a sample inlet line to the integrated On-Line Sampling (iOS) system for continuous on-line measuring. Or, if the Analyzer has the two-stream option, you can connect two sample inlet lines. As part of the sample-inlet installation process, also install a waste line. With this inlet system installed, you can conveniently switch between on-line sampling and discrete sampling using vials in the iOS.

There is no further installation required for On-Line and Portable TOC Analyzers to measure discrete grab samples from a vial. The iOS is ready for measuring grab samples without the need to disconnect the on-line inlet tubing. The Analyzer automatically shuts off on-line water flow when it detects that the iOS lid is closed and/or a vial is inserted into the iOS.

Also, select an appropriate *On-line* or *Grab* measurement mode on the *Setup* screen in the Analyzer’s firmware and then start the sampling on the *Home* screen. For complete step-by-step instructions, refer to [“Running a Sample Analysis” on page 108](#).



NOTE: The Laboratory TOC Analyzer arrives ready to measure discrete grab samples using the vial port (located on the front) of the Analyzer. It is not designed for continuous on-line sampling. Go to the next section, [“Step 11: Install the Waste Outlet— Laboratory TOC analyzer” on page 75](#), to install the waste outlet.

To connect the inlet tubing to the iOS

You will need the 1/4” PFA inlet tubing (with in-line filter) from the Analyzer’s Accessories Kit. Provide 3/4” OD plastic waste tubing.

Refer to [Figure 20: iOS](#) and [Figure 21: iOS — \(Optional\) Two Stream](#) when performing this instruction.

1. Ensure that the power to the Analyzer is off and disconnected.
2. Verify that the water source is disabled until the sample inlet system is completely installed and the Analyzer is ready to begin analysis.
3. Locate the 1/4" PFA inlet tubing (with the in-line filter) in the Accessories Kit and connect the tubing into the sample inlet (**B**) on the iOS System. Using a 9/16" open-end wrench, secure the nut. Do **not** over-tighten the nut.

Chapter 3 INSTALLATION

If the Analyzer has the two-stream option, you can connect the other inlet tubing into the second sample inlet (**B-2**) at this time.

4. Slide one end of the waste tubing over the waste outlet (barbed) fitting (**A**).
5. Position the tubing for a gravity drain of the waste water, collecting the waste in a glass laboratory cartridge or facility-approved waste or return line.



Warning

Hazardous reagents (oxidizer and acid) are used in the Analyzer. The waste stream from the Analyzer is acidic and must be disposed of properly. Consult federal, state, and local government regulations.

6. Ensure that the stainless steel tubing is connected to the bulkhead fitting, labeled *Sample Inlet* (installed at the factory).
7. Establish a water flow to the iOS System.
8. Adjust the flow to between ≥ 50 mL/min using the flow rate adjustment screw (**C**).



NOTE: The flow rate is controlled by a needle valve, which you can adjust by turning the screw located on the iOS. If the Analyzer has the two-stream option, there are two separate screws respective to each stream (**C**) and (**C-2**). Turn the appropriate screw clockwise to decrease flow, or counter-clockwise to increase flow.

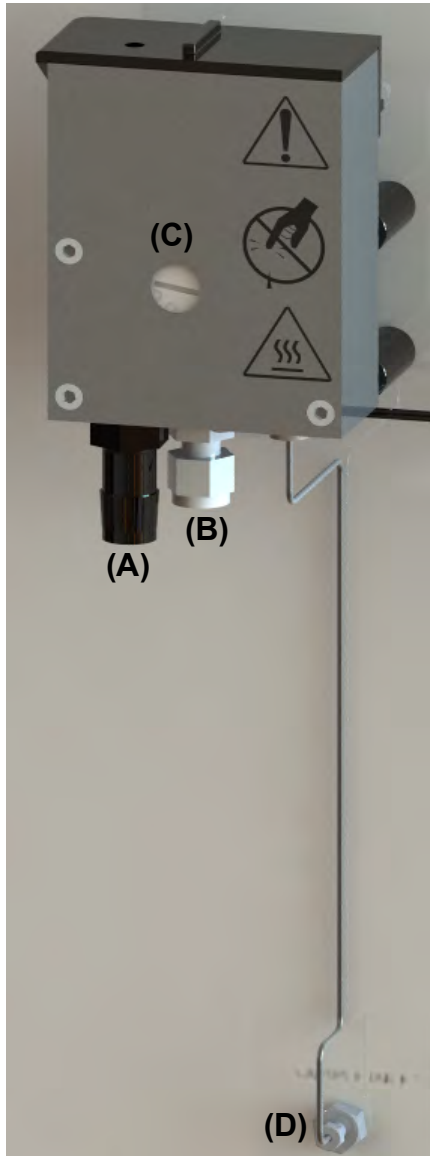

- (A) (Barbed) Waste Outlet Fitting
- (B) iOS Sample Inlet
- (C) Flow Rate Adjustment Screw
- (D) Analyzer Sample Inlet

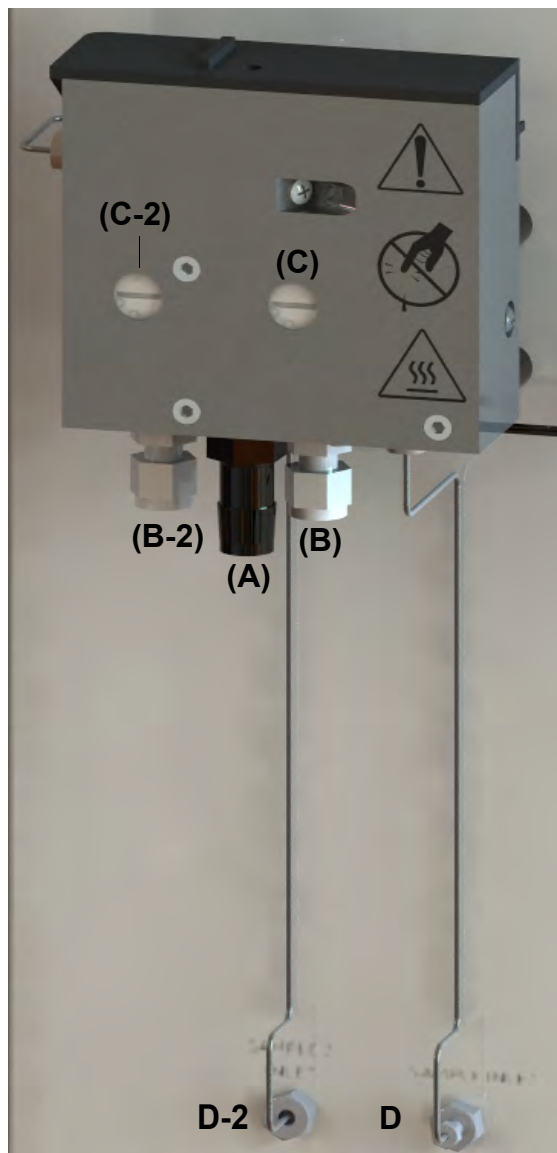

Figure 20: iOS

Chapter 3 INSTALLATION



- (A) (Barbed) Waste Outlet Fitting
- (B) Stream 1 iOS Sample Inlet
- (B-2) Stream 2 iOS Sample Inlet
- (C) Stream 1 Flow Rate Adjustment Screw
- (C-2) Stream 2 Flow Rate Adjustment Screw
- (D) Stream 1 Analyzer Sample Inlet
- (D-2) Stream 2 Analyzer Sample Inlet

Figure 21: iOS — (Optional) Two Stream

Warnings	
	<p>(On-Line and Portable TOC Analyzers) Operation of the Analyzer without the in-line filter on the sample inlet line will damage the Analyzer and void the warranty. To avoid damaging the Analyzer, install the filter and replace the filter element, as needed.</p>
	<p>Always make sure the sample is flowing through the iOS System and the DI water reservoir is filled before starting analysis.</p>

STEP 11: INSTALL THE WASTE OUTLET— LABORATORY TOC ANALYZER

(Laboratory TOC Analyzer Only)

To install the waste outlet

Locate the 1/8" OD plastic waste tubing with Swagelok fitting (provided in the Accessories Kit).

1. Using a 7/16" open-end wrench, disconnect the nut that connects to the *Waste* port.
2. Locate the 1/8" OD plastic waste tubing with Swagelok fitting (provided in the Accessories Kit).
3. Attach the Swagelok fitting to the *Waste* port, and use the 7/16" open-end wrench to tighten securely.
4. Position the hose for a gravity drain⁶ of the waste water, collecting the waste in a glass laboratory container or facility-approved waste or return line.

Warnings



Hazardous reagents (oxidizer and acid) are used in the Analyzer. The waste stream from the Analyzer is acidic and must be disposed of properly. Consult federal, state, and local government regulations.

⁶. The collecting laboratory container or line should be positioned lower than the iOS waste outlet to facilitate a gravity-induced flow.

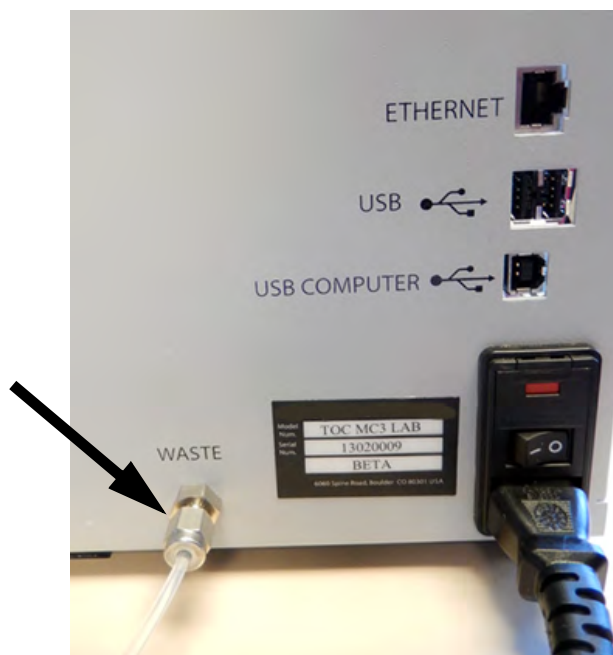

Figure 22: Waste Outlet Fitting — Laboratory TOC Analyzer

STEP 12: CONFIGURE BASIC ANALYZER SETTINGS

Before placing the Analyzer into service, record the installation of the *Acid* and *Oxidizer* reagent cartridges (installed in Step 4) on the *Consumables* tab of the *Maintenance* screen. In the appropriate *Acid* or *Oxidizer* section, press **RENEW** and verify the expiration dates. For more information refer to [“To renew an expiration date” on page 185](#).

Configure various basic settings in the Analyzer’s firmware using the touchscreen display (located on the front of the Analyzer). You will not need to change most of these settings unless you move the Analyzer, or reconfigure the operational environment.

This section includes how to configure basic analyzer settings, including:

- [“Enabling Password Protection \(Optional\)” — page 77](#)
- [“Naming the Analyzer Location \(Optional\)” — page 78](#)
- [“Setting Up the Data History Warning” — page 78](#)
- [“Configuring Ethernet Output” — page 80](#)
- [“Set Up the Printer \(Optional\)” — page 80](#)
- [“Set Up the USB Mouse \(Optional\)” — page 81](#)
- [“Exporting System Constants” — page 82](#)
- [“Configuring the Data I/O \(Optional\)” — page 82](#)

Enabling Password Protection (Optional)

The Sievers M5310 C TOC Analyzers include a *Password Protection* feature that allows you to set and require a password for entering and starting analysis, or gaining access to menu screens.

This section includes information for enabling Password Protection. For additional information about Password Protection, refer to [Chapter 5](#).

To enable Password Protection

1. On the *Security*  screen select the **ENABLE PASSWORD** option.

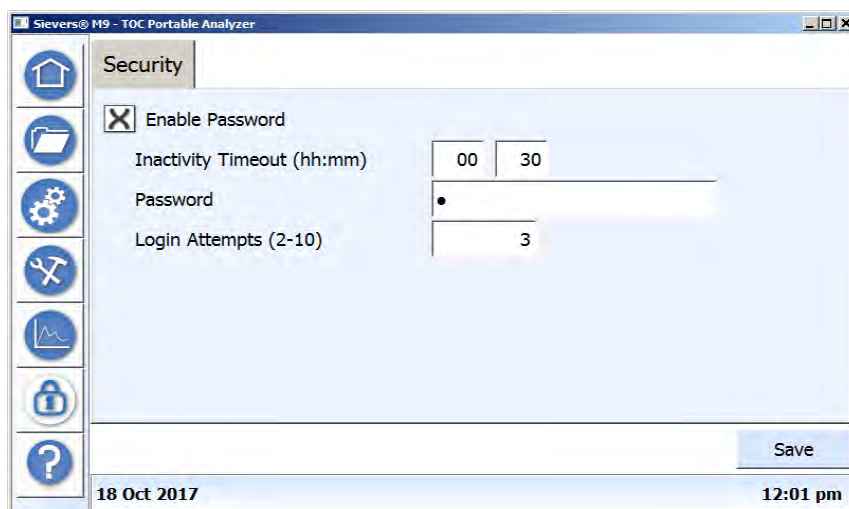

2. Complete the following:
 - **Inactivity Timeout (hh:mm)** — Defines the number of minutes and seconds of allowable keypad inactivity before users are required to re-enter their login information. The minimum timeout is one (1) minute.
 - **Password** — Press the field and use the alpha/numeric keypad to enter one password for all users. The maximum number of characters is 30.
 - **Login Attempts (2-10)** — Press the field and use the numeric keypad to enter a number for the number of inaccurate login attempts before the system will lock out the user.
3. Press **SAVE** to implement the password.
4. Record the new password in a secure location. ALL users will be required to enter this log in information to access the Analyzer's menus.

Naming the Analyzer Location (Optional)

To name an Analyzer Location

You can assign a name to the Analyzer, and this name will appear with printed and exported data. This is useful for readily distinguishing data collected from each unit when there are multiple Analyzers at a facility.

1. On the *Configuration*  screen, select the *Environment Preferences* tab.
2. Complete the following:



NOTE: *In printed and exported data, if you do not enter a name, the Analyzer name is blank.*

- **Analyzer Name** — Press the field and use the alpha/numeric pad to enter a name for this Analyzer.
 - **Location** — Press the field and use the alpha/numeric pad to enter the name for the location of the Analyzer.
 - **Service Provider** — Press the field and using the alpha/numeric pad and enter the name of the service provider.
3. Press **SAVE**.

Setting Up the Data History Warning

Before taking measurements, set the environment preferences for enabling warning message reminders for archiving data (retention of data) and/or backing up data (files created for exporting). Use the *Environment Preferences* tab on the *Configuration*  screen to define the period of time and age of data that when reached will generate a *Warning* message to archive the data history. Also, set the interval for generating a *Warning* message to back up data.

The ability to enable automatic database archiving is also available on the *Environment Preferences* tab.

To set database backup and archiving reminders

Enable or disable automatic database backup and archive reminders. The Analyzer will generate a corresponding warning message according to the interval set. After receiving a reminder message, or archive the database, as indicated. The *Database Backup* feature makes a copy of the database to a USB memory drive for any future restoration needs. The database remains active in the Analyzer. The *Database Archive* feature removes the database from the Analyzer and moves/saves it to a USB memory drive. Refer to [“Backing Up the Database” on page 135](#) or [“Viewing Archive Files” on page 136](#), as needed.



To schedule automatic archiving, select the corresponding option as described in [“To schedule automatic database archiving” on page 79.](#)

1. On the *Configuration*  screen, select the *Environment Preferences* tab.
2. Scroll down to the *Archive Options* section, *Archive Reminder* and select *Enable Database Archive Reminder*.
3. Press the *Interval (Days)* field and use the numeric keypad to enter a value. (For example, entering **30** creates the corresponding reminder every **30** days.) Press **OK**.
4. To disable the archive reminder, deselect the *Enable Database Archive Reminder* option.
5. Scroll down to the *Backup Reminder* section and select *Enable Database Backup Reminder*.
6. Press the *Interval (Days)* field and use the numeric keypad to enter a value. (For example, entering **30** creates the corresponding reminder every **30** days.) Press **OK**.
7. To disable the backup reminder, deselect the *Enable Database Backup Reminder* option.
8. Press **SAVE**.
9. To export the settings on this *Environment Preferences* tab, insert a USB memory drive into the device USB port and press **EXPORT**.

To schedule automatic database archiving

Enable or disable the Analyzer to automatically archive the database according to the frequency and start date and time set. The *Automatic Database Archive* feature removes the database from the Analyzer and moves/saves it to a USB memory drive.

1. Insert a USB memory drive into the device USB port.
2. On the *Configuration*  screen, select the *Environment Preferences* tab.
3. Scroll down to the *Automatic Archive* section and select the *Enable Automatic Database Archive* option.
4. Press the *Frequency (Days)* field and use the numeric keypad to enter a value (minimum 1 day and maximum 90 days) for the frequency of the automatic archives. (For example, entering **72** creates a database archive every **72** days.)
5. Press the first *Start Date & Time (hh:mm)* field and use the calendar to enter the start date.
6. Press the second and last *Start Date & Time (hh:mm)* field. Use the numeric keypad to enter the start date for the first automatic archiving and time (24-hour clock format, such as 13:22) for each automatic archiving. For example,

Chapter 3 INSTALLATION

entering **9** and **2** sets the time for the first and subsequent time database archive starts (9:02 am on the date set in step [5](#)).

7. To disable the automatic archive, deselect the *Enable Automatic Database Archive* option.
8. Press **SAVE**.
9. To export the settings on this *Environment Preferences* tab, insert a USB memory drive into the device USB port and press **EXPORT**.

Configuring Ethernet Output

To configure the Ethernet output

Use the *Configuration* screen to enable the Ethernet output and set up a manual (fixed) IP address or an automatic (dynamic) IP address.

After enabling the Ethernet output, use a third-party data acquisition software or a SCADA system with Modbus TCP/IP to support the collection of real-time instrument data and status information. For more information, refer to [Appendix C. "Working with Modbus."](#) To collect serial data strings, refer to [Appendix D. "Streaming Data Via Ethernet."](#)

1. On the *Configuration*  screen, press the *System Setup* tab.
2. Press **NETWORK SETUP**. The *Network Setup* dialog box appears.
3. Select the *Enable Network Setup* option.
4. Do one of the following:
 - Select the *Automatic* option for a dynamic IP address.
 - Select the *Manual* option for a fixed address and enter the IP Address and Net Mask numbers.
5. Press **OK**.

Set Up the Printer (Optional)

If a printer was installed in ["Step 9: Install Ethernet and External Devices."](#) set up the printer for printing.

To enable printing from the Analyzer

1. Connect the printer to the Analyzer, as described in ["Step 9: Install Ethernet and External Devices."](#)
2. On the *Configuration*  screen, select the *System Setup* tab.

3. Press **PRINTER SETUP** to display the *Printer Setup* dialog box.
4. Select the *Enable Printer* option.
5. Press **TEST PRINT** to verify that printer is working.

If the page does not print, verify that the printer cable is connected as described [“Step 9: Install Ethernet and External Devices.”](#) (See [page 67](#)).

6. Press **OK** to enable the printer.

Set Up the USB Mouse (Optional)

If a USB mouse was installed in [Step 9: Install Ethernet and External Devices](#), set up the USB mouse to interact with the Analyzer.

To interact with the Analyzer Using a USB Mouse

1. Connect the USB cable for a wired mouse to the Analyzer as described in [Step 9: Install Ethernet and External Devices](#).
2. On the *Configuration*  screen, select the *Environmental Preferences* tab.
3. Scroll down the list of preferences to display the *Enable Mouse (restart required)* option and select it.

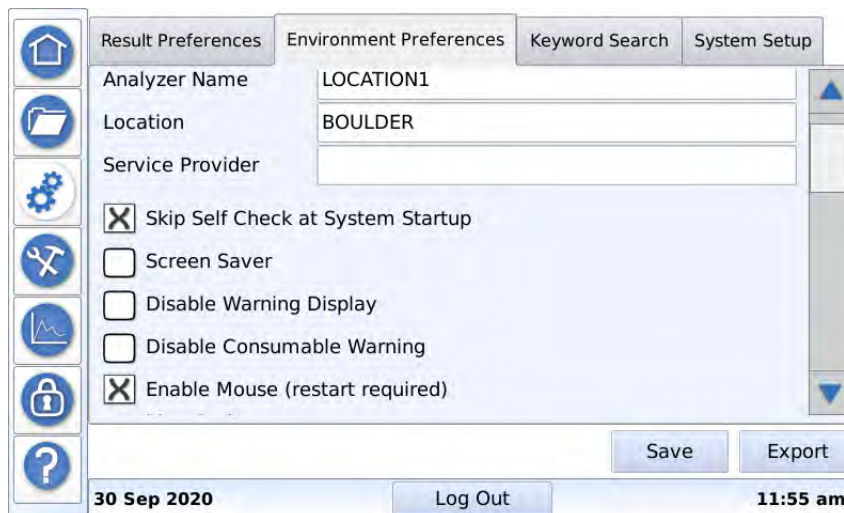

4. Press **SAVE**. A *Restart* message appears: *Mouse settings have been modified. Do you wish to restart?*
5. Press **YES**. The Analyzer automatically shuts down and restarts in order to activate the mouse. When the restart is complete, a cursor appears on the *Home*  screen.

Chapter 3 INSTALLATION

Exporting System Constants

System settings (constants) including calibration constants, reagent flow rates, and other key parameters are stored in the Analyzer's memory. Export these factory settings for future reference.

To export system settings (constants)

1. Insert a USB memory drive into one of the Analyzer's *USB HOST* ports.
2. On the *Maintenance*  screen, select the *Settings* tab.
3. Press **BACKUP SETTINGS**. The *Backup System Settings* dialog box appears.

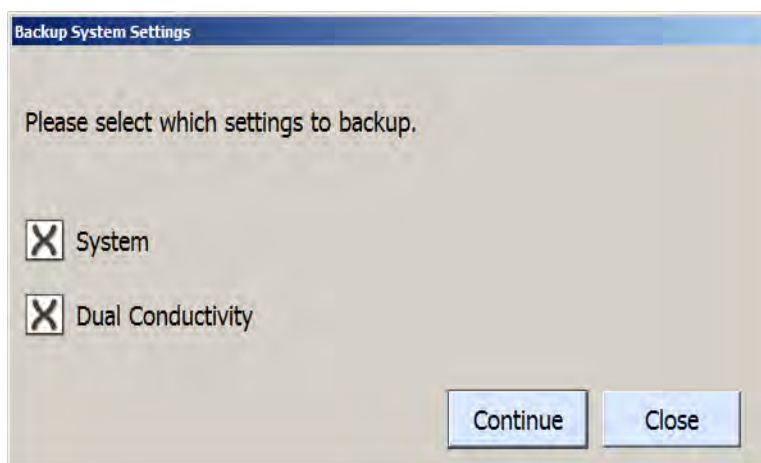

4. Select one or more of the following:
 - System
 - Dual Conductivity
5. Press **CONTINUE**. The Analyzer begins to retrieve system settings and reports its progress on the *Backup System Settings* dialog box.
6. When the backup is complete, a message appears that it is safe to remove the USB memory drive. Remove the USB memory drive and press **CLOSE**.

Configuring the Data I/O (Optional)

(Optional, On-Line, and Portable TOC Analyzers Only)

If you installed 4-20 mA outputs, alarms, and/or binary input (start/stop), set the appropriate values for those features now.



NOTE: You may need to consult with your remote operations center to determine some values.

To set up the Data I/O

Configure the settings for the 4-20 mA outputs.

1. On the *Configuration*  screen, select the *System Setup* tab.
2. Press **I/O SETUP**.
3. The *I/O Setup dialog* box appears.
4. Select the *4-20 mA Calibration* tab. Enter the calibration values for each 4-20 mA output (*output 1*, *output 2*, and *output 3*). (Drag the scroll bar to each output area.):
5. Select the *4-20 mA Output* tab and enter the following:
 - **Error** — Select one of the following values to set when the Analyzer issues an error: *1 mA*, *2.5 mA*, *4 mA*, *20 mA*, *22 mA* or *Hold Last*.
 - **Standby** — Select one of the following values to set when the Analyzer switches out of analysis mode into standby mode: *1 mA*, *2.5 mA*, *4 mA*, *20 mA*, *22 mA* or *Hold Last*.
 - **Warning** — Select one of the following values to set when the Analyzer issues a warning: *1 mA*, *2.5 mA*, *4 mA*, *20 mA*, *22 mA* or *Hold Last*.



NOTE: If you disable consumables warnings, the 4-20 mA output will not react to consumables warnings. For more information, refer to [“To set preferences for warnings” on page 122](#).

6. For one-stream On-Line TOC Analyzers, select the analog output value (TOC, TC, or IC) in the *Value Option* list for each of the following: *4-20 mA Output 1*, *Output 4-20 mA Output 2* and *4-20 mA Output 3*. (Drag the scroll bar to each output area.)
7. For two-stream On-Line TOC Analyzers, select one of the following analog output values in the *Value Option* list for each of the following: *4-20 mA Output 1*, *Output 4-20 mA Output 2*, and *4-20 mA Output 3*. (Drag the scroll bar to each output area.)
 - **TOC for Stream 1**
 - **TC for Stream 1**
 - **IC for Stream 1**
 - **TOC for Stream 2**
 - **TC for Stream 2**

Chapter 3 INSTALLATION

- **IC for Stream 2**
 - **TOC % Removal for Stream 2**
8. For each *Value Option*, set the following:
 - **Minimum Value** — Enter the lowest value (ppb) for output.
 - **Maximum Value** — Enter the highest value (ppb) for output.
 - **System Protocol** — Select one of the following for running system protocols: **REMAIN STANDBY** to output the *Standby* values entered in step [5](#) or **NORMAL PROCESS** to output actual values from protocol analyses.
 9. Press **OK** to save the information.

To enable Binary Input (start/stop)

Enable the binary input connection for communicating remote start and stop commands to the Analyzer.

1. On the *Configuration*  screen, select the *System Setup* tab.
2. Press **I/O SETUP**.
3. The *I/O Setup dialog* box appears.
4. Select the *4-20mA Output* tab.
5. Select **ENABLE BINARY INPUT**. The polarity options activate:
 - **Low** — Select to indicate a closed switch.
 - **High** — Select to indicate an open switch.
6. Press **OK** to save.

To configure the alarms

The Analyzer has two customizable alarm outputs that can be triggered if the measured TOC, TC, or IC exceeds a set value—or if a warning or error occurs. By default, both alarms are disabled. When external alarms connected to the Analyzer, use these instructions to set the alarm levels.

1. On the *Configuration*  screen, select the *System Setup* tab.
2. Press **I/O SETUP**.
3. The *I/O dialog* box appears.
4. Select the *Alarm Output* tab.
5. Enter the following for each alarm (*alarm 1*, *alarm 2*, *alarm 3*, and *alarm 4*) wired in the system (*Drag the scroll bar to each output area.*):
 - **Power Failure Polarity** — Select **Low** (closed switch) or **High** (open switch).

- **Value Option** — Set one of the following output values to trigger the alarm when its threshold value is exceeded: **TOC**, **TC**, **IC**, **Standby**, **Warning**, **Warning/Error**, **Error**, **Measurement Complete**, and **Break-in**.



NOTE: If you set one of the value options to **Warning** and you disable consumables warnings, the 4-20 mA output alarm will not go to the warning state when the system issues a consumables warning. For more information, refer to [“To set preferences for warnings” on page 122](#).

- **Threshold Value** — Set the threshold value to trigger the alarm. Press the *Threshold Value* field and use the alpha/numeric keypad to enter a value (ppb). Press and toggle the (>) symbol to indicate a threshold value greater than (>) or less than (<) the entered number.
6. Press **OK** to save.

Step 13: Flush and Rinse (optional) the Analyzer

Before placing the Analyzer into normal operation, flush the reagents to remove any gas bubbles that may have formed in the reagent lines. Next, run the Analyzer in *OnLine* or *Continuous* mode for a minimum of three hours to thoroughly rinse the sample flow path.

To flush and rinse the Analyzer

Use either a continuously flowing on-line stream or a large flask of low TOC DI water. If planning to use a flask water supply, use sipper tubing (with nut-and-ferrule compression fitting) from the Analyzer's Accessories Kit, a large flask of low TOC DI water, and a 1/4" open-end wrench.

Prepare the Analyzer

1. Connect to one of the following supplies of low-TOC DI water in preparation for both the reagent flush and the Analyzer rinse performed in this procedure:
 - *A continuously flowing on-line stream* — (*On-Line and Portable TOC Analyzers Only*) No additional setup is required if an inlet line was connected from a continuous low TOC DI water source in [Step 10: Install the iOS System](#). Proceed to step [3](#).
 - *A large flask (1000-2000 mL)* (*On-Line and Portable TOC Analyzers Only*) — Bypass the iOS system by removing the stainless steel tubing that connects the iOS to the Analyzer. Attach a sipper tube to the *Sample Inlet* port located on the back of the *Portable TOC Analyzer* or right side of the *On-Line TOC Analyzer*. For the two stream analyzer, add a second sipper tube or second large flask to flush both sides. Proceed to step [2](#).

Chapter 3 INSTALLATION

- A large flask (1000-2000 mL) (*Laboratory TOC Analyzer Only*) — Attach a sipper tube to the *Sample Inlet* port located on the lower left side of the Analyzer. Proceed to step [2.2](#).
 - A 40 mL vial — Fill a 40 mL vial with low-TOC DI water and insert into the vial port (*Laboratory TOC Analyzer*), iOS (*On-Line and Portable Analyzer*), or Autosampler Emergency rack (*Laboratory or Portable Analyzer*). (For the two stream analyzer the low-TOC DI water flows through stream 1.)
2. If the configuration uses a sipper tube with an iOS, do the following. Otherwise, go to step [3](#).
 - 2.1 Use a 1/4" open-end wrench to loosen the Valco nut that connects the stainless steel tubing from the iOS System to the *Sample Inlet* port.
Carefully pull the stainless steel tubing out of the *Sample Inlet* port (D). See "[Figure 20: iOS](#)" on page [73](#).
 - 2.2 Insert the sipper tube's Valco fitting into the *Sample Inlet* port and tighten the Valco nut finger tight. Using a 1/4" open-end wrench, tighten the nut an additional 1/8 turn.
 - 2.3 Place the other end of the sipper tube into a large flask containing 1000-2000 mL of low TOC DI water.
 3. Power on the Analyzer.
 4. Continue to *Flush the reagent syringes*.

Flush the reagent syringes

1. Continue from *Prepare the Analyzer*.
2. On the *Maintenance*  screen, select the *Advanced* tab.
3. Press **SYRINGE FLUSH**. The *Syringe Flush* screen appears with a message asking you to confirm that the water source is connected.
4. If the water source is connected, press **OK**. The *Syringe Flush* dialog box appears.
5. Press the *Number of Times to Move the Syringe* field, and select a number from **1-20**, based on the amount of water used. (The default value is **3**).
6. Press **Flush**. The Analyzer begins the syringe flush process and reports the time remaining on the screen.

When the syringe flush concludes, the Flush Time Remaining on the Syringe Flush dialog box will read **00:00:00**.

7. Press **CLOSE**.
8. On the *Home*  screen, press **SHUT DOWN** button and turn the power switch to **OFF**.

9. Visually inspect inside the Analyzer for any leaks, especially around the DI water reservoir. If a leak is detected, make sure all fittings are tight and secure.
10. Continue to *Create a Rinse Method*.

Create a Rinse Method

1. Continue from *Flush the Reagent Syringes*.
2. Create a Rinse Method. On the *Home*  screen, press **SETUP** to display the *Modify Method* dialog box.

3. Select **ONLINE** or **CONTINUOUS** (Laboratory) in the *Measurement Mode* field.
4. Do one of the following to name⁷ the method:
 - To create a new name when the *Method Name* field contains characters — Press **NEW** to display the alpha/numeric keypad. Use the keypad to enter **RINSE** and press **OK**.
 - To create a new name when the *Method Name* field is blank — Press the *Method Name* field to display the alpha/numeric keypad. Use the keypad to enter **RINSE** and press **OK**.



NOTE: After entering a new name, the **NEW** button changes to the **CANCEL** button. Press **CANCEL** to cancel the newly added name.

5. To change the default name in the *Stream* field, press inside the field to display the alpha/numeric keypad.

⁷. Special characters allowed in *Method Name* and *Stream Name* are the “at” symbol (@), asterisk (*), hyphen (-), underscore (_), period (.), and colon (;).

Chapter 3 INSTALLATION





6. Complete the following:
 - **ICR** (If installed) — Set to **ON**.
 - **Acid** — Set the value to 0.5 (mL/min).
 - **Oxidizer** — Set the value to 0.5 (mL/min).



NOTE: Setting the ICR online or offline here does not affect a TOC Autozero protocol. To run a TOC Autozero with the ICR in-line, enable the ICR on the TOC Autozero Setup dialog box. For more information, refer to [“To perform a TOC Autozero \(optional\)” on page 155](#).

7. Press **FLUSH** to display a numeric keypad. Use the keypad to enter **240**, or as preferred. The available range for the setting is between 240 - 480 seconds (4-8 minutes). Press **OK**.
8. Press **SAVE** to save the method and return to the *Home* screen. This will overwrite the previous *OnLine or Continuous (Laboratory)* method file, and erase any earlier settings.
9. Continue to *Rinse the Analyzer*.

Rinse the Analyzer

1. Continue from *Create a RINSE Method*.
2. On the *Home*  screen, press **RUN**  to begin the rinse.
3. Let the Analyzer run for at least three hours.
4. On the *Home*  screen, press **STOP**  to end the rinse.
5. Do one of the following:
 - *If a continuously flowing on-line stream was used* — No additional steps are required. The Analyzer is ready to begin normal sample analyses.
 - *If a large flask was used (1000-2000 mL) (On-Line and Portable TOC Analyzers Only)* — Reconnect the iOS system by reattaching the stainless steel tubing that connects the iOS to the Analyzer. Remove the sipper tube from the *Sample Inlet* port located on the back of the Analyzer, and connect the inlet tubing from an on-line water source. (You can also choose not to connect to an on-line water source.)

The *On-Line or Portable TOC Analyzer* is ready to begin normal sample analyses.

- *If you used a large flask (1000-2000 mL) (Laboratory TOC Analyzer Only)* — Remove the sipper tube from the *Sample Inlet* port located on the lower left side of the Analyzer.

The *Laboratory TOC Analyzer* is ready to begin normal sample analyses.

STEP 14: INSTALL A SIEVERS AUTOSAMPLER

(Laboratory and Portable TOC Analyzers)

If you are planning to use a Sievers Autosampler with the Analyzer, install it now. Refer to the *Sievers Autosampler Installation Guide* for complete installation instructions.



NOTE: Verify the communication cable connections. Refer to [“Connection Problems Directly following a Sievers Autosampler Installation” on page 228.](#)

THIS PAGE IS INTENTIONALLY LEFT BLANK.

4

OPERATION

OVERVIEW

The Sievers M5310 C TOC Analyzers utilize a touch-sensitive color LCD for all menu selection activities. This chapter describes the operation activities of the Analyzer.

If your configuration will include a Sievers Autosampler, consult the *Sievers DataPro2 Software User's Guide* for details on operating the Analyzer and Sievers Autosampler using the Sievers DataPro2 Software.



NOTE: *Screenshots in this chapter show the Sievers M9 Portable TOC Analyzer firmware. However, the functionality is the same for all models, unless specifically noted.*

SAMPLING USING THE iOS SYSTEM



Figure 23: iOS — On-Line and Portable TOC Analyzers

With the Analyzer configured in an on-line configuration you can conveniently switch between on-line sampling and discrete sampling using the iOS. There is no need to change the configuration to analyze a standard with the iOS System. The Analyzer automatically shuts off on-line water flow when it detects that the iOS lid is closed and/or a vial is inserted into the iOS.

To use, stop analysis and slide the iOS System lid open to the left. Wait 30 seconds for sample to drain from the iOS System and then insert a 40-mL vial containing sample or the standard.

After establishing water flow to the iOS System, adjust the flow rate so that flow exiting the waste line is ≥ 50 mL/min. The flow rate is controlled by a needle valve, which is adjusted by the screw on the iOS. Turn the screw clockwise to decrease flow, and turn the screw counter-clockwise to increase flow.

Always stop analysis before opening the iOS System lid. If the flow sensor is On, opening the iOS System lid while analysis is taking place causes the flow sensor to activate and stop analysis. If the flow sensor is Off, opening the iOS System lid while analysis is taking place results in air being drawn into the Analyzer.

TWO-STREAM OPERATION

(On-Line TOC Analyzer Only)

If the Analyzer is configured with the 2-stream option, before running the analysis, select the stream to be analyzed. To switch between one stream or another, select **STREAM 1** or

STREAM 2 in the user defined method using the *Setup* dialog box (*Home*  screen > **SETUP** button). You can save one or more methods for *Stream 1* and one or more methods for *Stream 2* (each with unique settings) to use again. You can then easily switch between streams by selecting the stream and method without having to re-plumb the inlet.

THE ANALYZER SCREENS

Overview of the Analyzer Screens

The Analyzer's touchscreen display changes according to the screen you select from the *Standard* toolbar (located on left side of the screen).

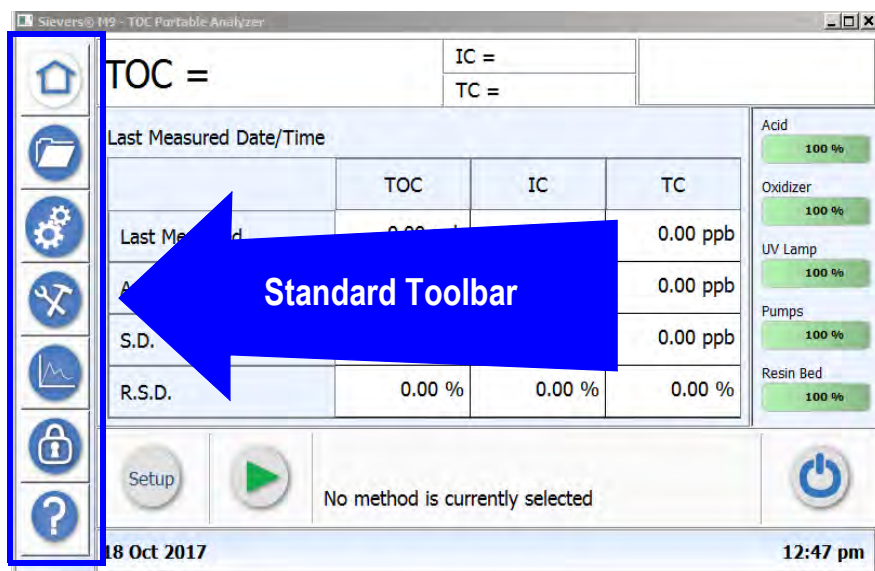









Figure 24: The Standard Toolbar

When the Analyzer is first powered on, the Analyzer begins initialization to check the status of consumables and prepare for taking measurements. The Analyzer performs a *Self Check* and displays the related status and an opportunity to view the summary. Press **CLOSE** on the *Self Check* dialog box to display the *Home*  screen.

To display other screens, simply press one of the following icons on the Analyzer's **Standard Toolbar** to display the related screen:

TABLE 4: THE ANALYZER'S STANDARD TOOLBAR

	<p>HOME (For more screen details, go to page 95.)</p>	<p>Sample Setup Configuration, Running samples, Viewing Errors and Warnings, Quick View of Consumable Status, Instrument Shut Down, and Password Protection Enabled Indicators</p>
	<p>PROTOCOLS (For more screen details, go to page 115.)</p>	<p>System Protocols (<i>Calibration, Autozero, Verification, and Municipal Tests</i>) and User Defined Methods</p>
	<p>CONFIGURATION (For more screen details, go to page 119.)</p>	<p>Result Preferences, Environment Preferences, Keyword Search, and System Setup ()</p>
	<p>MAINTENANCE (For more screen details, go to page 131.)</p>	<p>Consumables, IC Removal (<i>if ICR is installed</i>), Error History, Diagnostics, Advanced (<i>Clean Screen, Upgrade Firmware, Archive (move) Database, Back Up (copy) Database, Syringe Flush, Archive Viewer, Restore Database, and Autosampler Connection</i>), and Settings (<i>Create Master Settings, Load Master Settings, Back Up (copy) Settings, Restore Settings, and Reset Settings</i>)</p>
	<p>DATA VIEW (For more screen details, go to page 140.)</p>	<p>Data History, Calibration History, and Municipal Test History</p>
	<p>SECURITY (For more screen details, go to page 142.)</p>	<p>Password Protection</p>
	<p>HELP (For more screen details, go to page 143.)</p>	<p>Location, Firmware, IP Address, MAC Address, Serial Number, and Bar Code (Detail button: Firmware Version, Supported DataPro2 Versions; Database Usage button: list of database tables and available records in each table)</p>



NOTE: *If Password Protection is enabled, log in before starting analysis or proceeding to the Home screen.*

THE HOME SCREEN

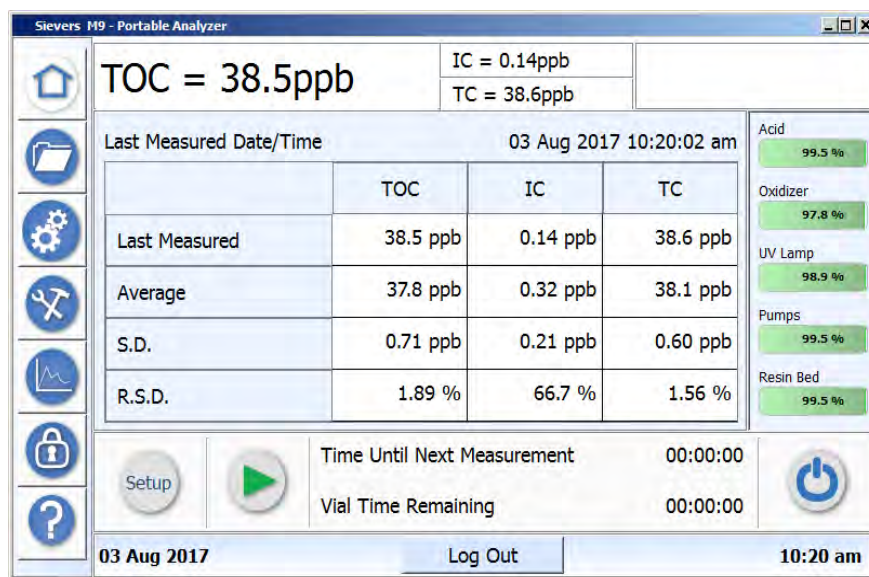

Figure 25: The Home Screen

When the Analyzer is first powered on, the *Startup* screen displays basic SUEZ contact information and the firmware version number. The Analyzer then begins initialization to check the status of consumables and prepare for taking measurements. When the Analyzer is done with initialization, the *Home* screen appears.

Use the *Home* screen to set up and run sample analyses of TOC measurements. The Analyzer reports the sampling status and data on this screen during the process, including the TOC (IC and TC) data along with mean standard deviation (SD) and relative standard deviation (RSD) of the last measured sample.

For 2-stream M5310 C TOC Analyzers, the stream ID (Stream 1, Stream 2, or user-defined stream name) appears on the lower-right portion of the screen for available measurements.

Monitor remaining consumables' levels using the indicators on the right of the screen. Any warnings or errors appear on the top right of the screen. Press this area to view the specific message(s) and access the *Diagnostics* screen. (For additional information on the Diagnostics screen, see [Chapter 8, "Troubleshooting."](#))



NOTE: On the Home screen, you can disable the display of all warnings, or only the warnings for consumables. For more information, see ["To set preferences for warnings" on page 122.](#)

Chapter 4 OPERATION

This section includes instructions for:

- [“Creating Grab Mode User-Defined Methods” on page 96](#)
- [“Creating On-Line User-Defined Methods” on page 100](#)
- [“Running a Sample Analysis” on page 108](#)
- [“Setting Reagent Rates” on page 110](#)
- [“Viewing Consumables Levels” on page 112](#)
- [“Reviewing Errors and Warnings” on page 113](#)
- [“Shutting Down the Instrument” on page 115](#)

USER DEFINED METHODS

Before running a sample, first define the measurement mode (*On-Line* or *Grab*) and related settings and save these settings as a user defined Method. A Method is simply a pre-defined set of settings that can be selected to run a current or future sample analysis.

The following step-by-step instructions are provided for:

- [“Creating Grab Mode User-Defined Methods” on page 96](#)
- [“Creating On-Line User-Defined Methods” on page 100](#)

Creating Grab Mode User-Defined Methods

The following step-by-step instructions are provided for creating user defined methods in *Grab* mode.

To create or change a user defined method — GRAB MODE

When selecting *Grab* mode, specify the number of replicate measurements and rejects.

1. On the *Home*  screen, press **SETUP**. The *Modify Method* dialog box appears.

2. Select *Grab* in the *Measurement Mode* field to measure TOC from a vial port or iOS.
3. Do one of the following:
 - *To create a new method* — Press **NEW** to display the numeric keypad. Use the keypad to enter a name¹ for the method and press **OK**. The new name appears in the *Method Name* field.
 - *To change an existing method* — Select the configuration in the *Method Name* field.
4. (Optional) Type a new name in the *Sample Name* field.
5. To operate the Analyzer with the ICR, set the **ICR** indicator to *On*.



NOTE: *Setting the ICR online or offline here does not affect a TOC Autozero protocol. To run a TOC Autozero with the ICR in-line, enable the ICR on the TOC Autozero Setup dialog box. For more information, refer to [“To perform a TOC Autozero \(optional\)” on page 155](#).*

6. To use the Autoreagent feature (recommended for unknown samples), do the following. Otherwise, go to step [7](#).
 - Set the **AUTOREAGENT** indicator to *On*. The Acid and Oxidizer indicators change to the inactive state. The Analyzer automatically calculates and implements the flow rate for oxidizer and acid for this method, The data is captured and the new calculated values appear on each indicator.
 - Continue to step [8](#).

¹. Special characters allowed in *Method Name* and *Sample Name* include the *at* symbol (@) or the asterisk (*).

Chapter 4 OPERATION

7. To manually set the flow rate of the reagents for known specific flow rates, do the following:
 - Verify that the Autoreagent indicator is set to *Off* to ensure that the **ACID** and **OXIDIZER** buttons are in an active state.
 - Press **ACID** to display the numeric keypad. Use the keypad to enter a value and press **OK**.
 - Press **OXIDIZER** to display the numeric keypad. Use the keypad to enter a value and press **OK**.



NOTE: For recommended reagent rates, refer to [Table 6, “Recommended Acid Flow Rates — Sievers M5310 C TOC Analyzers.” on page 111](#) and [“Recommended Oxidizer Flow Rates” on page 110](#). For more information, see [“Setting Reagent Rates” on page 110](#).

8. Do the following:
 - Press **FLUSH** to display the numeric keypad. Use the keypad to enter a value for the flush time and press **OK**.
 - Press **REPEATS** to display the numeric keypad. Use the keypad to enter a value for the number of replicate measurements of the TOC sample and press **OK**.
 - Press **REJECTS** to display the numeric keypad. Use the keypad to enter a value for the number of replicate measurements to be rejected in calculating average values and standard deviations and press **OK**.
9. Do one of the following:
 - *To save a new method* — Press the *Sample Name* field and use the keypad to enter a name for the method and press **OK**. Press **SAVE** to save the new method and return to the *Home* screen.
 - *To save an existing method* — Press **SAVE** to save with the existing name and return to the *Home* screen. To save with a new name, press **SAVE AS**. Review the confirmation message that appears. Press **YES** to confirm and return to the *Home* screen.

To create or change a *TOC Removal Grab Method*

The *TOC Removal Grab* feature is available in Sievers M5310 C TOC Analyzers. When selected, the Analyzer measures an **Influent** and **Effluent** sample and then automatically calculates and reports the percent TOC removal.

TOC % Removal is calculated as follows:

$$\frac{(\text{Influent TOC Average}) - (\text{Effluent TOC Average})}{(\text{Influent TOC Average})} \times 100$$

1. On the *Modify Method* dialog box (*Home* screen>**SETUP**), select **TOC Removal Grab** in the *Measurement Mode* field.

2. Do one of the following:
 - *To create a new method* — Press **NEW** to display the alphanumeric keypad. Use the keypad to enter a name² for the method and press **OK**. The new name appears in the *Method Name* field.
 - *To change an existing method* — Select the configuration in the *Method Name* field.
3. Select **Influent** in the *Vial Name* field.
4. (Optional) Type a name in the *Sample Name* field for this Influent sample.
5. Press and change the various method settings, as needed, for the Influent sample. (For additional information, refer to [“To create or change a user defined method — GRAB MODE” on page 96.](#))



NOTE: The Autoreagent periodicity feature is not available with the TOC Removal Grab mode.

6. Select **Effluent** in the *Vial Name* field.
7. (Optional) Type a name in the *Sample Name* field for this Effluent sample.

². Special characters allowed in *Method Name* and *Sample Name* are the “at” symbol (@), asterisk (*), hyphen (-), underscore (_), period (.), and colon (:).

Chapter 4 OPERATION

8. Press and change the various method settings, as needed, for the Effluent sample. (For additional information, refer to [“To create or change a user defined method — GRAB MODE” on page 96.](#))
9. Do one of the following:
 - *To save a new method* — Press the *Sample Name* field and use the keypad to enter a name for the method and press **OK**. Press **SAVE** to save the new method and return to the *Home* screen.
 - *To save an existing method* — Press **SAVE** to save with the existing name and return to the *Home* screen. To save with a new name, press **SAVE AS**. Review the confirmation message that appears. Press **YES** to confirm and return to the *Home* screen.

Creating On-Line User-Defined Methods

The following step-by-step instructions are provided for creating user defined On-Line methods.

- [“Using TOC Removal Online Measurement \(Optional\)” on page 100](#)
- [“Using On-Line Timed Measurement” on page 103](#)
- [“Creating an On-Line Mode Method” on page 105](#)

USING TOC REMOVAL ONLINE MEASUREMENT (OPTIONAL)

(Sievers M5310 C On-Line TOC Analyzer with a Two-Stream Configuration Only)

The *TOC Removal Measurement* feature is available in Sievers M5310 C On-Line TOC Analyzer configured with two streams. When selected, the Analyzer measures Stream 1 and then Stream 2 (each defined as either **Influent** or **Effluent**) according to the defined lag time (period of time set between the two measurements).

To use the *TOC Removal Online*

Configure the *TOC Removal Measurement* and *Stream Naming* options beforehand and then select *TOC Removal Online* as the Measurement Mode when creating a user defined method.

1. On the *Configuration*  screen, press the *System Setup* tab.
2. Press **ONLINE SETUP**. The *Online Setup* dialog box appears.

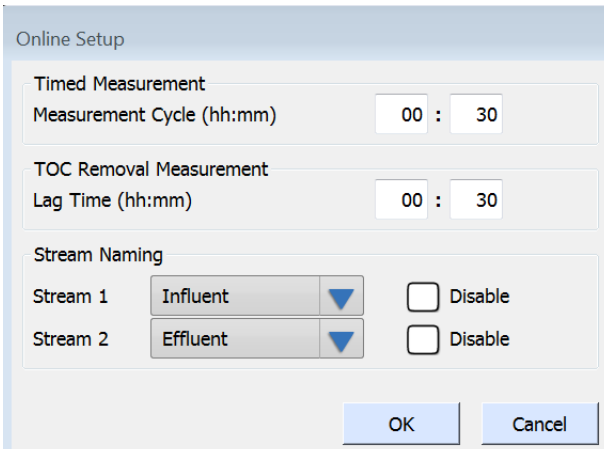

3. Set the Lag Time in (hh:mm) for the Analyzer to switch from taking measurements on one stream to taking measurements on the other stream.
4. Set *Stream 1* and *Stream 2* as either **Influent** or **Effluent**.
5. Press **OK** to save.
6. Go to the *Modify Method* dialog box (*Home* screen>**SETUP**) and select **TOC Removal Online** in the *Measurement Mode* field.

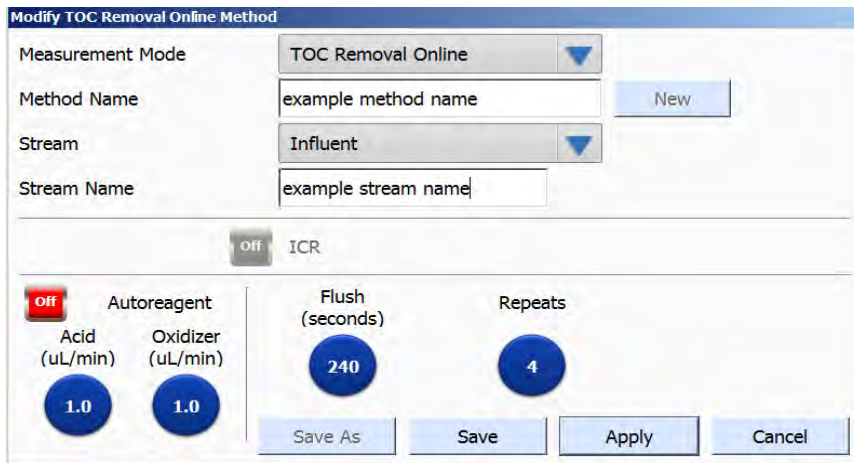

Chapter 4 OPERATION

7. Do one of the following:
 - *To create a new method* — Press **NEW** to display the numeric keypad. Use the keypad to enter a name³ for the method and press **OK**. The new name appears in the *Method Name* field.
 - *To change an existing method* — Select the configuration in the *Method Name* field.
8. Select **Influent** in the *Stream* field.
9. (Optional) Type a name in the *Stream Name* field for this Influent stream.
10. Press and change the various method settings, as needed, for the Influent stream. (For additional information, refer to [“To create or change a user defined method — ONLINE MODE” on page 105.](#))



NOTE: *The Autoreagent periodicity feature is not available for the TOC Removal Online mode.*

11. Select **Effluent** in the *Stream* field.
12. (Optional) Type a name in the *Stream Name* field for this Effluent stream.
13. Press and change the various method settings, as needed, for the Effluent stream. (For additional information, refer to [“To create or change a user defined method — ONLINE MODE” on page 105.](#))
14. Do one of the following:
 - *To save a new method* — Press the *Sample Name* field and use the keypad to enter a name for the method and press **OK**. Press **SAVE** to save the new method and return to the *Home* screen.
 - *To save an existing method* — Press **SAVE** to save with the existing name and return to the *Home* screen. To save with a new name, press **SAVE AS**. Review the confirmation message that appears. Press **YES** to confirm and return to the *Home* screen.

³. Special characters allowed in *Method Name* and *Stream Name* are the “at” symbol (@), asterisk (*), hyphen (-), underscore (_), period (.), and colon (:).

USING ON-LINE TIMED MEASUREMENT

The *On-Line Timed Measurement* feature is available in Sievers M5310 C TOC Analyzers configured with one or two streams. Timed Measurement helps conserve reagents when continuous measurements are not necessary. Instead, the instrument will repetitively take one measurement for each user-defined time interval. If the Analyzer is configured with two streams, the Analyzer will first measure Stream 1 and then automatically measure Stream 2.

To use the *On-Line Time Measurement* feature

Configure the *On-Line Time Measurement* and *Stream Naming* options beforehand and then select *On-Line Timed Measurement* as the Measurement Mode when creating a user defined method.

1. On the *Configuration*  screen, press the *System Setup* tab.
2. Press **ONLINE SETUP**. The *Online Setup* dialog box appears.

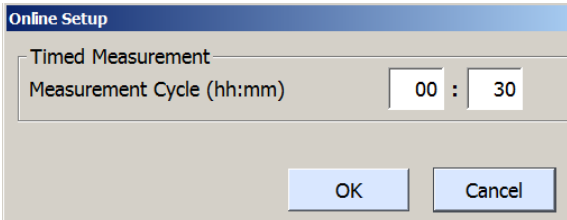

Online Setup Dialog Box — One-Stream Analyzer

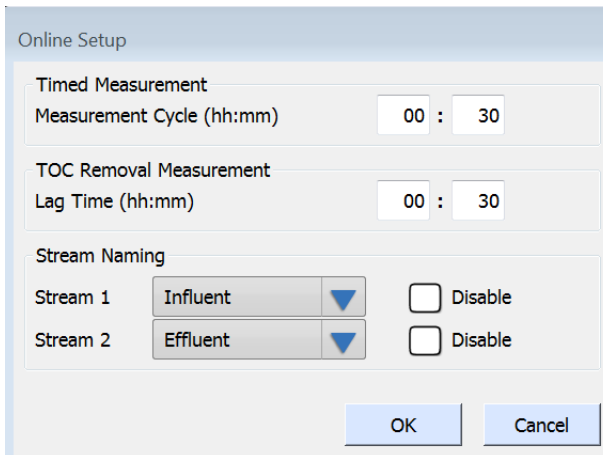

Online Setup Dialog Box — Two-Stream

3. In the *Timed Measurement* section, set the Measurement cycle in (hh:mm) for the Analyzer to repetitively take measurements on a stream.
4. (Optional for a two-stream Analyzer) Set *Stream 1* and *Stream 2* as either **Influent** or **Effluent**.



NOTE: The starting stream is the stream set as the Influent.

5. (Optional for a two-stream Analyzer) Select the *Disable* option for a stream, if applicable.
6. Press **OK** to save.

Chapter 4 OPERATION

7. Go to the *Modify Method* dialog box (*Home* screen>**SETUP**) and select **On-Line Timed** in the *Measurement Mode* field.

The screenshot shows the 'Modify Timed Online Method' dialog box. It contains the following fields and controls:

- Measurement Mode:** A dropdown menu set to 'On-Line Timed'.
- Method Name:** A text input field containing 'example method name' and a 'New' button to its right.
- Stream:** A dropdown menu set to 'Stream 1'.
- Stream Name:** A text input field containing 'example stream name'.
- ICR:** A section with a toggle switch set to 'Off'.
- Autoreagent:** A section with two sub-sections: 'Acid (uL/min)' and 'Oxidizer (uL/min)'. Each has a red 'Off' indicator and a blue circular dial set to '1.0'.
- Flush (seconds):** A blue circular dial set to '240'.
- Repeats:** A blue circular dial set to '4'.
- Buttons:** 'Save As', 'Save', 'Apply', and 'Cancel' buttons at the bottom.



NOTE: The *Stream* field only appears on M5310 C Analyzers configured with two streams.

8. Do one of the following:
 - *To create a new method* — Press **NEW** to display the numeric keypad. Use the keypad to enter a name⁴ for the method and press **OK**. The new name appears in the *Method Name* field.
 - *To change an existing method* — Select the configuration in the *Method Name* field.
9. (For a two-stream Analyzer) Select **Stream 1** in the *Stream* field.
10. (Optional) Type a name in the *Stream Name* field for Stream 1.
11. Press and change the various method settings, as needed. (For additional information, refer to [“To create or change a user defined method — ONLINE MODE” on page 105.](#))
12. (For a two-stream Analyzer) Select **Stream 2** in the *Stream* field and (optional) type a name in the *Stream Name* field for Stream 2.
13. (For a two-stream Analyzer) Press and change the various method settings, as needed, for Stream 2. (For additional information, refer to [“To create or change a user defined method — ONLINE MODE” on page 105.](#))

⁴. Special characters allowed in *Method Name* and *Stream Name* include the *at* symbol (@) or the asterisk (*).

14. Do one of the following:

- *To save a new method* — Press the *Sample Name* field and use the keypad to enter a name for the method and press **OK**. Press **SAVE** to save the new method and return to the *Home* screen.
- *To save an existing method* — Press **SAVE** to save with the existing name and return to the *Home* screen. To save with a new name, press **SAVE AS**. Review the confirmation message that appears. Press **YES** to confirm and return to the *Home* screen.

CREATING AN ON-LINE MODE METHOD

To create or change a user defined method — ONLINE⁵ MODE

1. On the *Home*  screen, press **SETUP** to display the *Modify Method* dialog box.



NOTE: The *Stream* field only appears on M5310 C Analyzers configured with two streams.

2. Select **OnLine** (On-Line or Portable Analyzers) or **Continuous** (Laboratory Analyzers) in the *Measurement Mode* field to measure TOC continuously from a sample stream. The *Modify Online Method* dialog box appears.

5. For Laboratory Analyzers, this mode is “Continuous.”

Chapter 4 OPERATION

3. Do one of the following:
 - *To create a new method* — Press **NEW** to display the numeric keypad. Use the keypad to enter a name⁶ for the method and press **OK**. The new name appears in the *Method Name* field.
 - *To change an existing method* — Select the configuration in the *Method Name* field.
4. For a two-stream Analyzer, select **Stream 1** or **STREAM 2** in the *Stream* field
5. (Optional for a two-stream Analyzer) Type a name in the *Stream Name* field.
6. Press **REPEATS** to display the numeric keypad. Use the keypad to enter a value for the number of replicate measurements of the TOC sample and press **OK**.



NOTE: *(Two-Stream Analyzer Models Only) When one stream has been disabled, the Repeats setting is inactive (and the indicator appears dimmed). The Analyzer will not check for a current rep as the active stream will automatically run continuously.*

7. (Optional) To operate the Analyzer with the ICR, set the **ICR** indicator to *On*.



NOTE: *Setting the ICR online or offline here does not affect a TOC Autozero protocol. To run a TOC Autozero with the ICR in-line, enable the ICR on the TOC Autozero Setup dialog box. For more information, refer to [“To perform a TOC Autozero \(optional\)”](#) on page 155.*

8. *(One-Stream TOC Analyzers Only)* For two-stream Analyzers the **AUTOREAGENT** button is not available; therefore, skip this step and go to [12](#). To use the Autoreagent feature (recommended for unknown samples) for one-stream Analyzers, set the **AUTOREAGENT** indicator to *On*. The **AUTOREAGENT** button is now active and the *Oxidizer* and *Acid* indicators are now inactive.
9. (Optional) Press **AUTOREAGENT** to enable Autoreagent Periodicity. The *Autoreagent Periodicity Setup* dialog box appears.

⁶. Special characters allowed in *Method Name* and *Stream Name* are the “at” symbol (@), asterisk (*), hyphen (-), underscore (_), period (.), and colon (:).

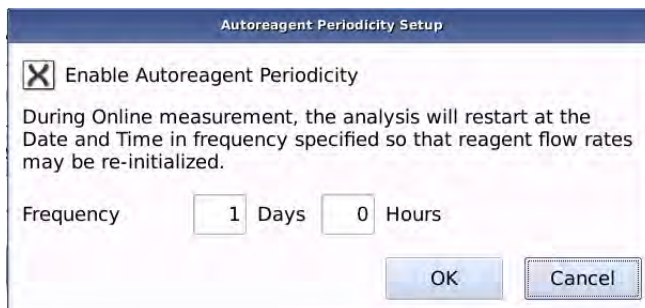

10. Select the *Enable Autoreagent Periodicity* option.



NOTE: With the *Autoreagent* option activated, the Analyzer automatically calculates, implements, and displays the proper reagent flow rates for the method. The Analyzer captures these new rates in the Data Record.

11. Complete either the *Days* or *Hours* field, but not both. Press inside the field to display the numeric keypad and use the keypad to enter a value. Press **OK** to return to the *Autoreagent Periodicity Setup* dialog box.

12. To manually set the flow rate of the reagents for known specific flow rates, do the following:

- Verify that the Autoreagent indicator is set to *Off* to ensure that the **ACID** and **OXIDIZER** buttons are in an active state.
- Press **ACID** to display the numeric keypad. Use the keypad to enter a value and press **OK**.
- Press **OXIDIZER** to display the numeric keypad. Use the keypad to enter a value and press **OK**.



NOTE: For recommended reagent rates, refer to [“Recommended Acid Flow Rates — Sievers M5310 C TOC Analyzers” on page 111](#) and [“Recommended Oxidizer Flow Rates” on page 110](#). For more information, see [“Setting Reagent Rates” on page 110](#).

13. Press **FLUSH** to display the numeric keypad. Use the keypad to enter a value for the flush time and press **OK**.

14. For a two-stream Analyzer, return to step [4](#) to configure **Stream 2**.

15. Do one of the following:



- *To save a new method* — Press the *Sample Name* field and use the keypad to enter a name for the method and press **OK**. Press **SAVE** to save the new method and return to the *Home* screen.
- *To save an existing method* — Press **SAVE** to save with the existing name and return to the *Home* screen. To save with a new name, press **SAVE As**.

Chapter 4 OPERATION

Review the confirmation message that appears. Press **YES** to confirm and return to the *Home* screen.

16. To run a sample analysis using this completed method, refer to [“To run a sample analysis” on page 108](#).

Running a Sample Analysis



After creating a user defined method, as described in the previous procedures, the Analyzer is ready to take TOC measurements. You can run a sample analysis by applying a user defined method from the *Home*  screen (**SETUP** > *Modify Current Method* dialog box) or from the *Protocols*  screen (*User Defined* tab).

To run a sample analysis

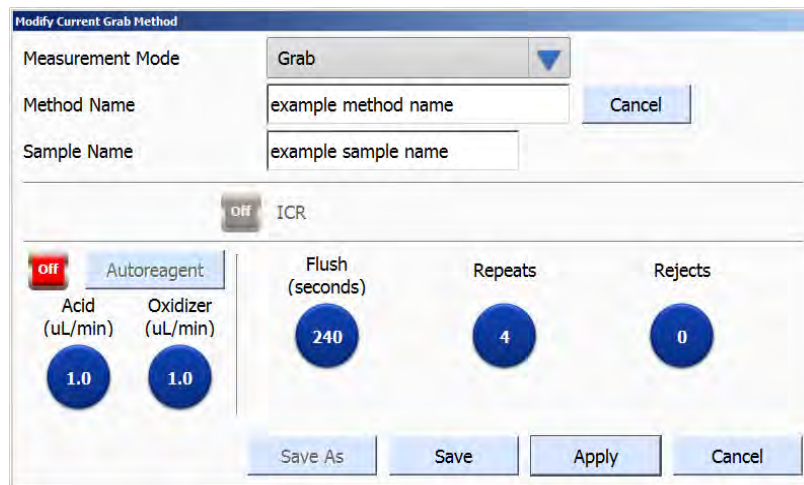
1. On the *Home*  screen, press **SETUP** to display the *Modify . . . Method* dialog box.



2. Select the measurement mode in the *Measurement Mode* field to use:
 - **GRAB**
 - **TOC REMOVAL GRAB**
 - **ONLINE** (*Portable and On-Line TOC Analyzer Only*)
 - **ON-LINE TIMED** (*Portable and On-Line TOC Analyzer Only*)
 - **CONTINUOUS** (*Laboratory TOC Analyzer Only*)
 - **TOC REMOVAL ONLINE** (*On-Line TOC Analyzer Only*)
3. Select the method to use in the *Method Name* field.
4. (Optional) Assign a sample name. Press inside the *Sample Name* field to display the numeric keypad. Use the keypad to enter a name for the sample and press **OK**. The new name appears in the *Sample Name* field.

- Press **APPLY** to use this method and return to the *Home* screen.
- Press **RUN**  to begin the sampling. The Run icon turns to a red square  and the sampling progress and measurement data appears on the screen in real time.

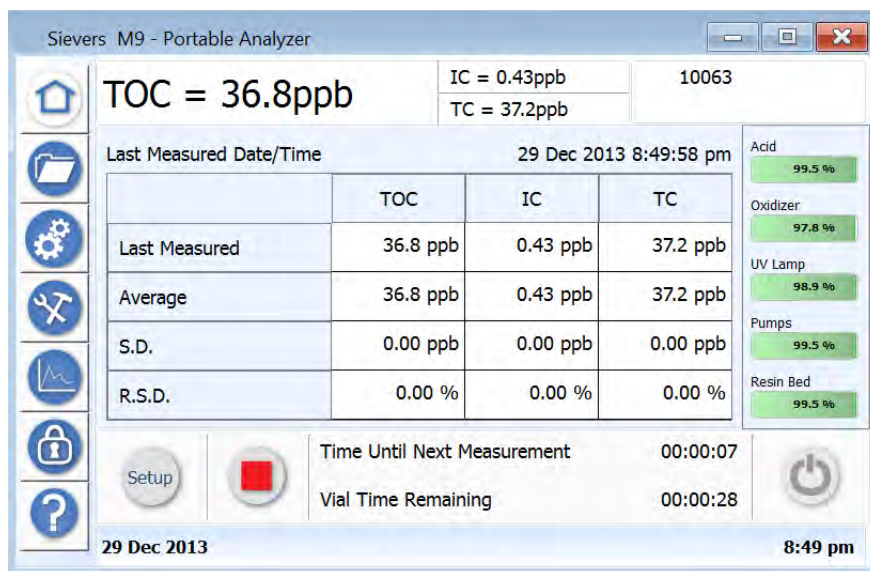

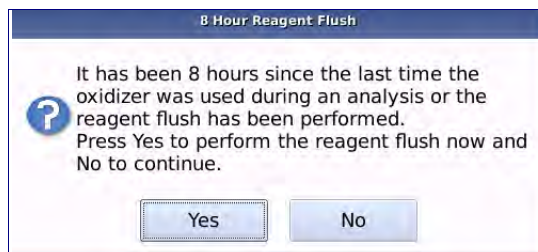

- If a reagent/syringe flush or analysis has **not** been performed in the last eight hours and Oxidizer is set >0, the *8 Hour Reagent Flush* message appears. If a reagent/syringe flush **HAS** been performed in the last eight hours and/or Oxidizer is set to 0, go to step [12](#).



- (If performing a reagent/syringe flush) Make sure you are connected to an on-line or continuous source of deionized (DI) Water — If an on-line source of DI water is not available, adjust the sample inlet so that the Analyzer can draw from at least a 1,000 mL container of DI water. Or, if operating in grab mode, insert a 40 mL vial of low-TOC DI water into the iOS System (*On-Line or Portable Analyzer*) or Vial Port (*Laboratory Analyzer*).
- Press **YES** to perform the reagent flush. The Analyzer displays a water-source connection message. Press **OK** to confirm.
- When the flush is complete, remove the vial used for flushing.
- Press **OK** to continue.

Chapter 4 OPERATION

- When the analysis has completed Time Until Next Measurement and Vial Time Remaining read 00:00:00 and the Run icon changes back to green triangle  .
- To review details and a trend graph of sampling results, go to the *Data View*  screen. Refer to [“The Data View Screen” on page 140](#).

Setting Reagent Rates

When creating an *On-Line* or *Grab* mode method, manually set the reagent flow rates or set the Analyzer for the Autoreagent mode. Using the Autoreagent mode, the Sievers M5310 C TOC Analyzer automatically calculates and implement the proper reagent flow rates.

AUTOREAGENT MODE

When the Autoreagent function is active, the Analyzer performs a preliminary measurement of each new sample before it performs the measurements for reporting. The Analyzer uses the preliminary measurement to determine the correct acid and oxidizer flow rates for the subsequent analysis of that sample. The Analyzer display these new flow rates and captures these settings in the Data Record.

MANUALLY SETTING FLOW RATES

Refer to [Table 5](#) and [Table 6](#) to manually set the reagent flow rates.

TABLE 5: RECOMMENDED OXIDIZER FLOW RATES

<i>TOC Concentration</i>	<i>Oxidizer Flow Rate</i>
<1 ppm	0.0 - 0.7 µL/min
0-25 ppm	1.4 - 7.5 µL/min
1 - 5 ppm	0.7 - 1.4 µL/min
5 - 10 ppm	0.7 - 2.8 µL/min
25 - 50 ppm	2.8 - 13.5 µL/min

TABLE 6: RECOMMENDED ACID FLOW RATES — SIEVERS M5310 C TOC ANALYZERS

<i>IC Concentration</i>	<i>Acid Flow Rate</i>
50 - 100 ppm	1.0-2.0 µL/min
0-50 ppm	0.5-1.0 µL/min
Deionized water	Not applicable
Modify the acid flow rate according to the alkalinity of the sample water. For example, use an acid flow rate of approximately 1 µL/min for alkalinity of 100 mg/L. For all samples, verify that the pH of waste is <2 and adjust the acid flow rate, as needed.	

UNDERSTANDING ANALYSIS TIMES

The following table describes the analysis times for the instrument various sample modes.

TABLE 7: SAMPLE ANALYSIS TIME BY REAGENT MODE

<i>Parameter</i>	<i>Manual Reagent Mode*</i>		<i>Autoreagent Mode*</i>	
	No ICR or ICR Bypassed	ICR Inline	No ICR or ICR Bypassed	ICR Inline
Time to first measured value	8 minutes	12 minutes	21.7 minutes	25.7 minutes
Time for flush and four replicate measurements	14 minutes	18 minutes	27.7 minutes	31.7 minutes
* Additional time may be required if the reagent syringes must be filled during the analysis.				

Chapter 4 OPERATION

Viewing Consumables Levels

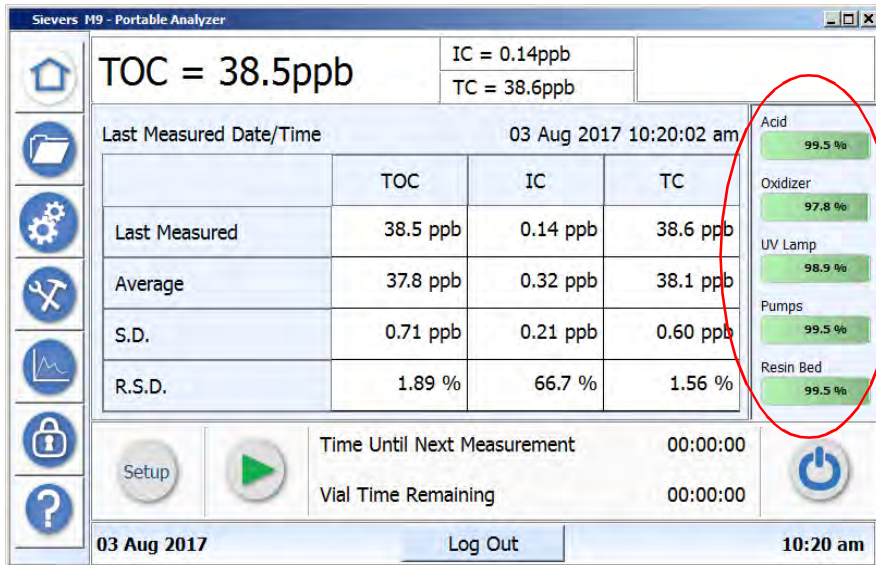

Figure 26: Consumable Level Indicators

The *Home* screen displays a quick view of levels for each of the Analyzer's consumables: Acid, Oxidizer, UV lamp, (sample) pumps, and resin cartridge. Status indicators on the *Home* screen include a status bar that displays the percentage of useful life remaining for each consumable.

Press any one of the consumables indicators to display the *Consumables* tab (Figure 27). Volume, expiration dates, days remaining, and installation dates are listed for each consumable item. For information on replacing consumables, see [Chapter 7. "Maintenance."](#)

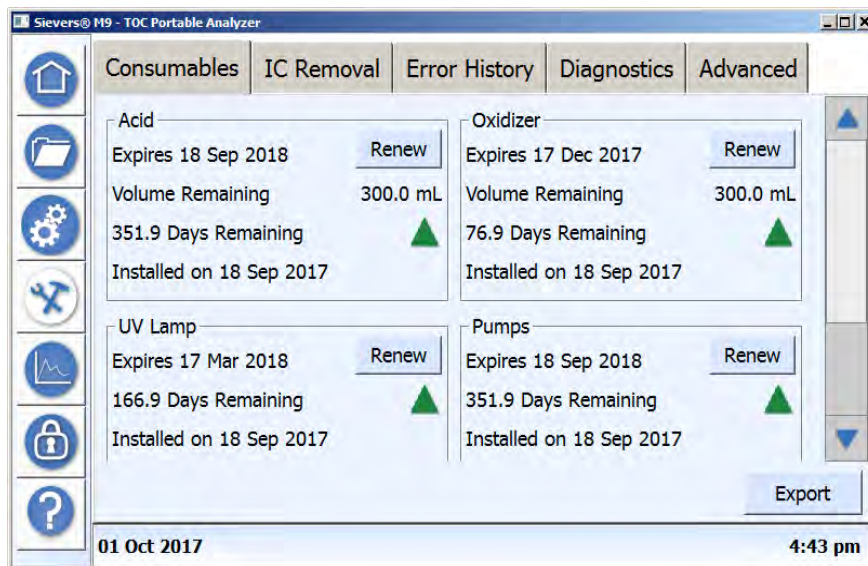

Figure 27: Consumables Tab

Reviewing Errors and Warnings

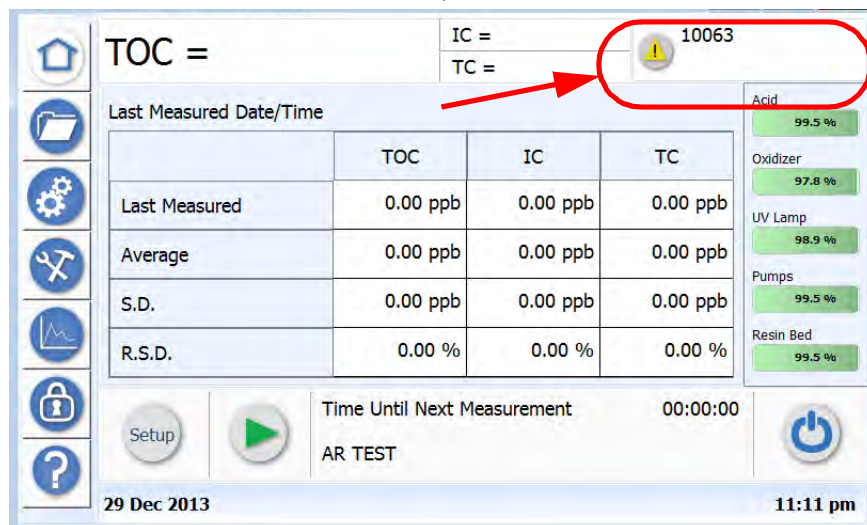



Figure 28: The Home Screen — Warning and Error Indicator

A warning icon  (yellow for warning or red for error) appears on the top-right portion of the *Home* screen to indicate that the Analyzer has issued a warning or error message.



NOTE: If you do not want an icon to appear on the Home screen for any warning, or if you do not want an icon to appear for any warning about consumables, you can disable the display of those warnings. For more information, see [“To set preferences for warnings” on page 122](#). All warnings are still displayed on the Error History tab located on the Maintenance  screen.

Press the icon to display a dialog box with the date, error number, error description, a brief suggestion for corrective action, time of last occurrence, and the number of times this warning or error has occurred. Use the buttons on the dialog box to view a cumulative list of recent and historical error and warning messages. The Analyzer issues two levels of messages:



Warnings — Warnings do not stop TOC measurements, but may indicate that corrective action is required.

Errors — Errors are critical alerts that require immediate corrective action.

See Chapter 8, "Troubleshooting" for a detailed description of the warnings and errors.

Chapter 4 OPERATION

To review a warning or error

1. Press the warning icon  (yellow for warning or red for error) located on the top-right corner of the *Home*  screen. The *Detailed Information* dialog box appears.



2. Press **PREVIOUS** or **NEXT** to scroll through multiple messages.
3. Press **CLEAR** to acknowledge and remove the displayed message from the list, or press **CLEAR ALL** to remove all unacknowledged warning and error messages.
4. When you have completed viewing the message(s), press **OK** to return to the *Home* screen.



NOTE: You can also access warning and error information on the *Error History* tab located on the *Maintenance*  screen. Refer to [“The Maintenance Screen” on page 131](#) for more information.



NOTE: You can review and clear warnings and errors remotely if you have third-party data acquisition software or a SCADA system with Modbus TCP/IP support. For additional information, refer to [Appendix C, “Working with Modbus.”](#)

Shutting Down the Instrument

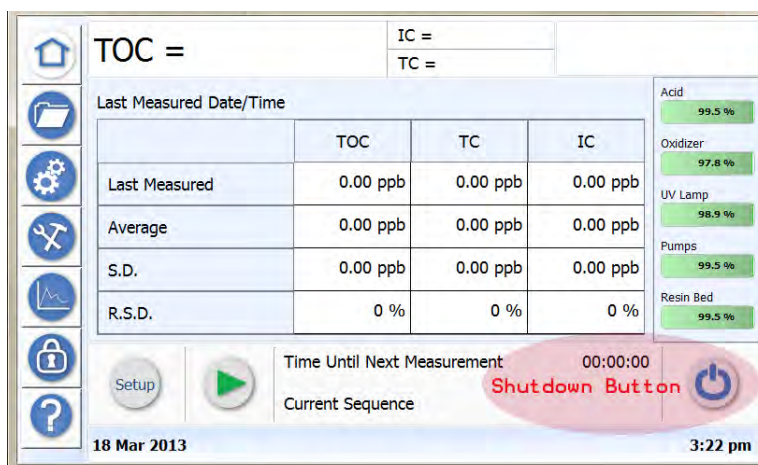



Figure 29: The Shut Down Button

Each Analyzer model (*On-Line*, *Laboratory*, and *Portable*) has an **ON/OFF** power switch located on the outside of the Analyzer⁷. However, before switching the power switch to **OFF**, FIRST press the **SHUT DOWN**  button on the Analyzer's *Home*  screen to avoid damaging the Analyzer's operating system. Next, switch the physical power switch (located on the outside of the Analyzer) to **OFF** to complete the power-down cycle.

Refer to [“Powering On and Off the Analyzer” on page 64](#) for additional information.

THE PROTOCOLS SCREEN



This screen contains the System Protocols and User Defined Methods.

⁷. A power **ON/OFF** switch is located on the back of the *Laboratory and Portable TOC Analyzers* and on the right side of the *On-Line TOC Analyzer*.

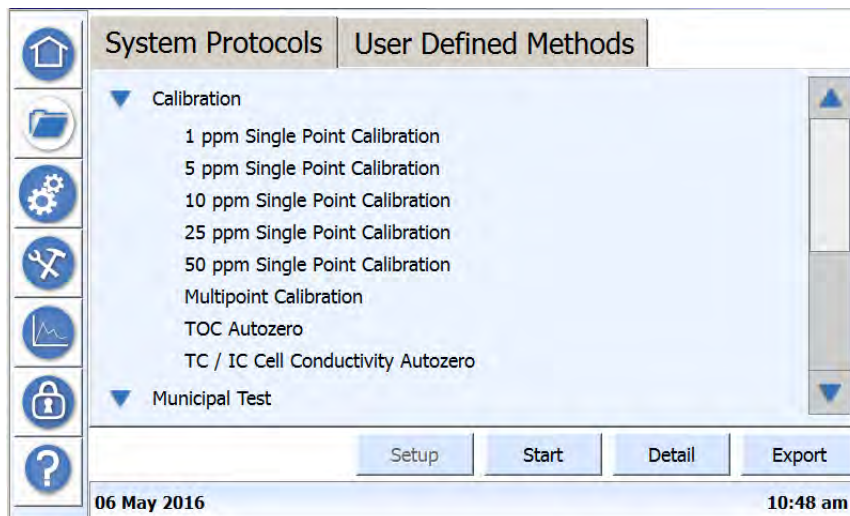

System Protocols

Refer to the following for additional information and step-by-step instructions for running system protocols.

- Calibration Protocols — See [“Calibration” on page 149](#), [“Performing a TOC Autozero \(optional\)” on page 154](#), and [“To perform a TC/IC Cell Conductivity Autozero \(optional\)” on page 223](#).



User Defined Methods

This section included instructions for running a sample analysis using a previously created user-defined method.

To run a sample analysis (*Protocols* screen)

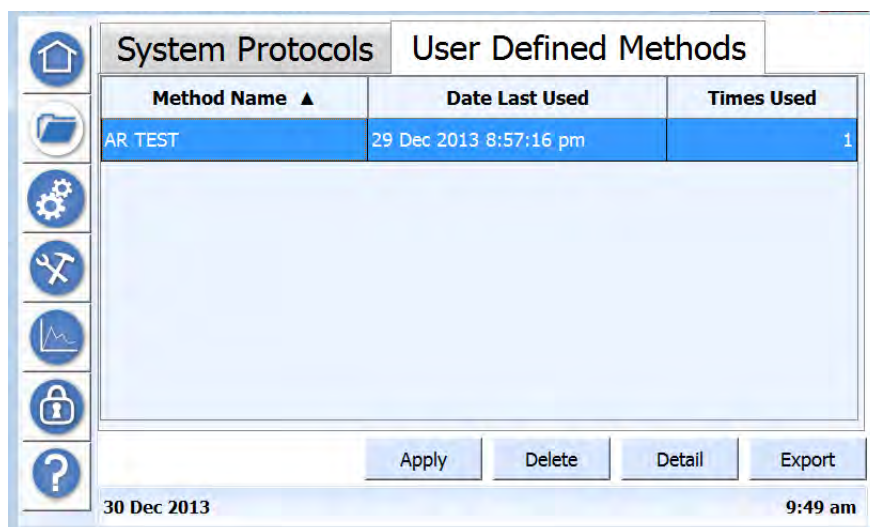
1. On the *Protocols*  screen, select the **USER DEFINED METHODS** tab.



2. Select the line with the measurement mode to use.
3. To view details of the user defined method, press **DETAIL**. (Press **OK** to return to the tab view.)
4. Press **APPLY** to run a sample analysis using this method. The *Home* screen appears.
5. Press **RUN**  to begin the sampling. The Run icon turns to a red square  and the sampling progress and measurement data appears on the screen in real time.

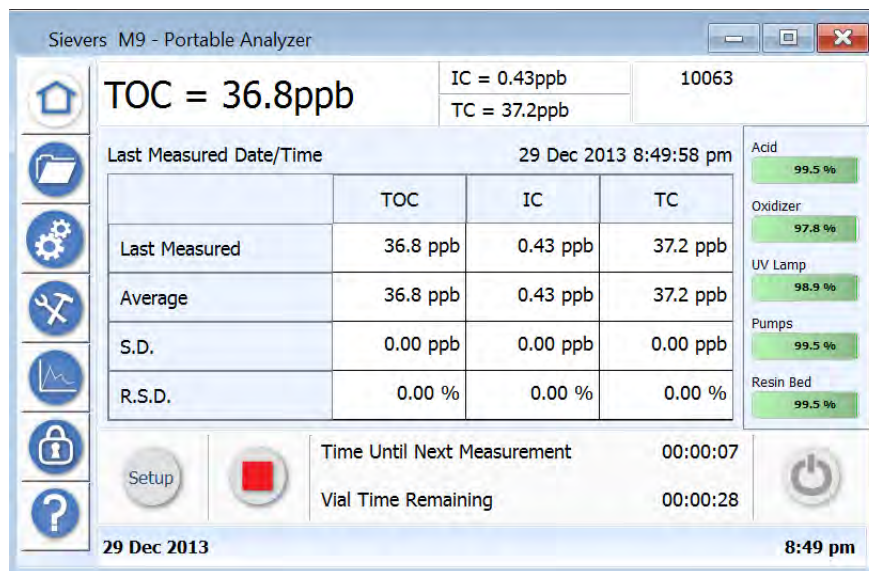

- When the analysis has completed Time Until Next Measurement and Vial Time Remaining read 00:00:00 and the Run icon changes back to green triangle .
- To review details and a trend graph of sampling results, go to the *Data View* screen. Refer to [“The Data View Screen” on page 140](#).

To export user defined method details

- On the *Protocols*  screen, select the **USER DEFINED METHODS** tab.

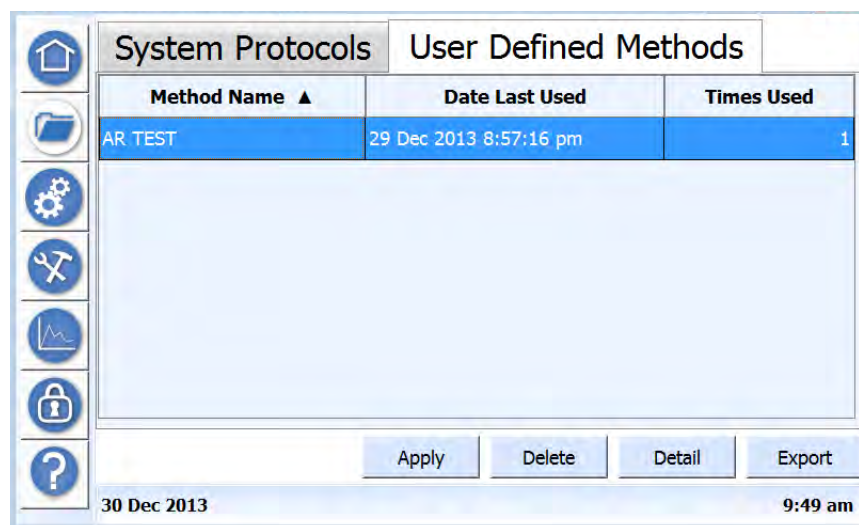

- Select the line with the user defined method to export.

3. To view details of the user defined method, press **DETAIL**. (Press **OK** to return to the tab view.)
4. To export the user defined method, insert a USB memory drive into one of the USB host ports and press **EXPORT**.

THE CONFIGURATION SCREEN

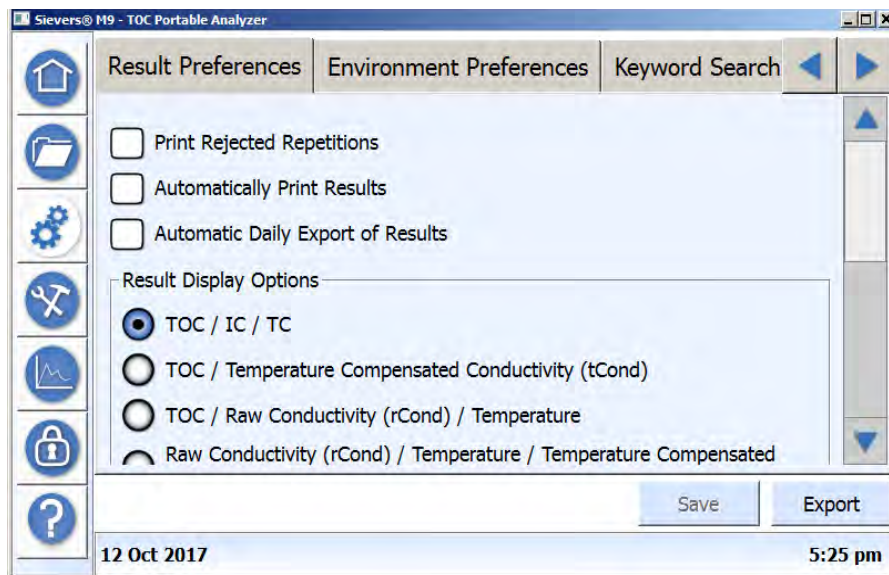

Figure 30: The Configuration Screen

Use this screen to specify preferences and basic operation settings for the Analyzer configuration. If the sample conditions for your application remain relatively constant, these settings seldom require re-configuration especially if the Autoreagent flow rate mode is used.

Configure settings using the following tabs:

- [“Using the Result Preferences Tab” on page 120](#)
- [“Using the Environment Preferences Tab” on page 121](#)
- [“Using the Keyword Search Tab” on page 124](#)
- [“Using the System Setup Tab” on page 125](#)

Using the Result Preferences Tab

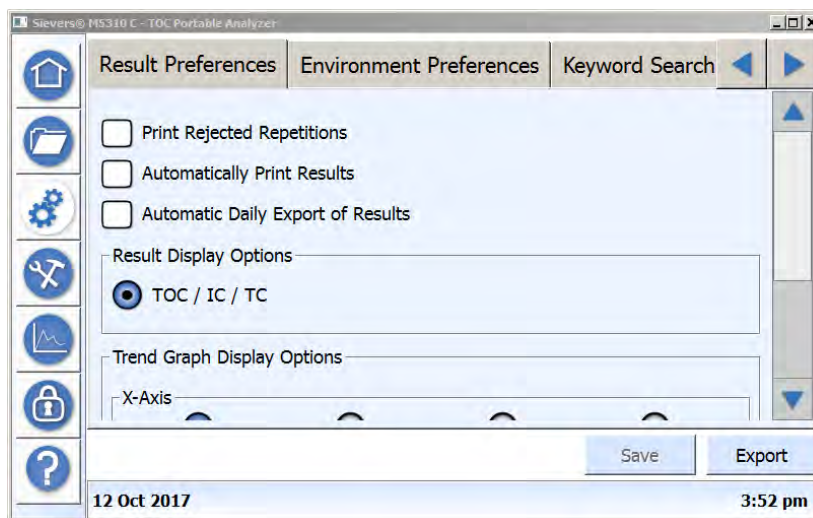



Figure 31: The Result Preferences Tab

Use this tab to set preferences for printing and exporting results, as well as to define settings for the (sampling analysis) trend graph. The trend graph appears on the *Home* screen when the **ON-LINE** mode is selected as the *Measurement Mode* on the *Modify Current Online Method* dialog box.

To set result preferences

1. On the *Configuration*  screen, select the *Result Preferences* tab.
2. Select any or all of the following options to set preferences for printing and exporting results:
 - Print Rejected Repetitions
 - Automatically Print Results
 - Automatic Daily Export of Results
3. Select or deselect the TOC/IC/TC result display option as the type of data to graph.
4. Select one of the following *Trend Graph Display* options for the data on the X-Axis (time ranges): 1 Hour, 2 Hours, 4 Hours, 8 Hours, 1 Day, 2 Days, or 1 Week.
5. Select one of the following *Trend Graph Display* options for the TOC range on the Y-Axis:
 - Auto — Select to have the Analyzer automatically calculate the appropriate TOC range.

- Manual — Select to activate the *Min* and *Max* fields and enter a value in ppb units in each field.

6. Press **SAVE**.

Using the Environment Preferences Tab

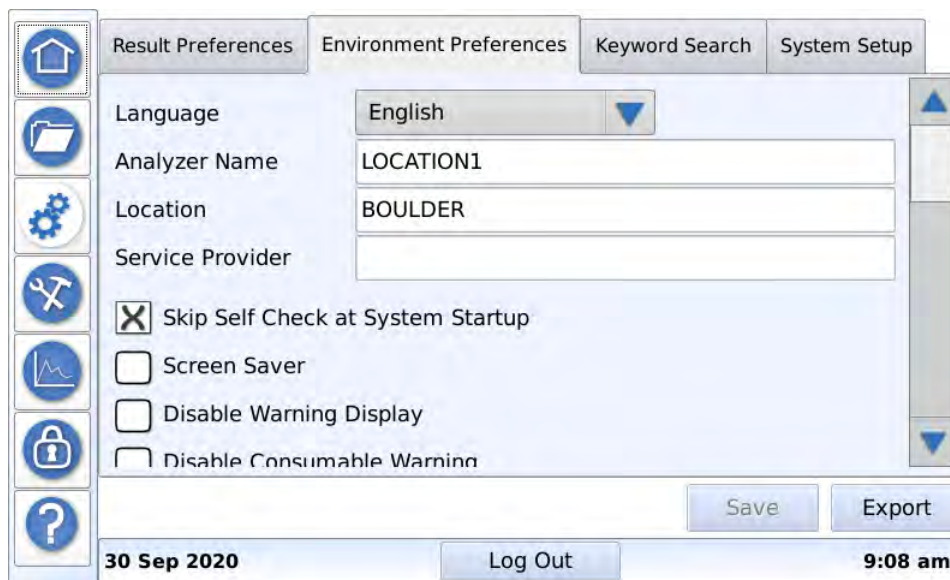

Figure 32: The Environment Preferences Tab



Use this tab to set the language (*Simplified Chinese, Japanese, or English*). There are also options for assigning a name, location, and service provider to the Analyzer to appear on printed and exported data. This feature is particularly useful if you have multiple Analyzers at your facility and want to easily distinguish data collected from each.

Additionally, this tab contains options for:

- Skipping the *Self Check* at startup
- Displaying a screen saver
- Disabling the display of all warnings on the *Main* screen
- Disabling the display **and** all other outputs of warnings for consumables
- Enabling a mouse to interact with the Analyzer
- Archiving interval and data age
- Backup interval
- Time and date format





To set the language

To change to a new language other than the default language (English) configured at the factory, perform the following steps.

1. On the *Configuration*  screen, select the *Environment Preferences* tab.
2. Select one of the preferred languages for the Analyzer:
 - English (*1st position in language option list*)
 - Simplified Chinese (*2nd position in language option list*)
 - Japanese (*3rd position in language option list*)
3. Press **SAVE** (*1st button on the lower-right of screen*).
4. Restart the Analyzer for this change to take effect. On the *Home*  screen, press the **SHUT DOWN** button and then restart the Instrument.

To set preferences for warnings

Two environmental preferences control how the Analyzer processes warnings:

- *Disable Warning Display* — This option prevents a warning icon from appearing on the *Home*  screen when a warning occurs. The warning is still logged, and it still impacts your 4-20 mA outputs and alarms based on how you have configured warnings. For example, you could disable the warning display and then set up your 4-20 mA output to hold the last value if you do not want the warning to impact the output. On the other hand, if you disable the warning display but set up a 4-20 mA alarm to trigger on Warnings, you would still get the alarm even though nothing would show up on the *Home*  screen.
 - *Disable Consumable Warning* — This option is specific to warnings associated with the expiration of the UV lamp, pump head, resin bed, and acid/oxidizer. The option not only prevents a warning icon from appearing on the *Home*  screen when a warning occurs, it also suppresses any changes to 4-20 mA state or alarm state (even if you have them configured to respond to other warnings), and it suppresses the registers on Modbus coils. When you select this option, consumables warnings are visible only on the *Error History* tab on the *Maintenance*  screen.
1. On the *Configuration*  screen, select the *Environment Preferences* tab.
 2. Select or de-select the following preferences:
 - Disable Warning Display
 - Disable Consumable Warning
 3. Press **SAVE**.

To set other environment preferences

1. On the *Configuration*  screen, select the *Environment Preferences* tab.
2. Press inside each of the following fields to display the alphanumeric keypad. Use the keypad to enter a name and press **OK**. The new name appears in the corresponding field.
 - Analyzer Name
 - Location
 - Service Provider
3. Select or de-select the following display preferences:
 - Skip *Self Check* at System Startup
 - Screen Saver
 - Enable Mouse (restart required)For more information, see [“To interact with the Analyzer Using a USB Mouse” on page 81.](#)
4. Select or de-select these Archive options and set the corresponding values:
 - *Archive Reminder*
 - *Automatic Archive*For for information, see [“To set database backup and archiving reminders” on page 78.](#)
5. Select or de-select the *Backup Reminder* option and set the corresponding value.
For for information, see [“To schedule automatic database archiving” on page 79.](#)
6. Select one of the following for the time formats to display:
 - 01:42:58 (am/pm)
 - 13:42:58 (24 Hour)
7. Select one of the following date formats to display:
 - 16 Jan 2012 (Text Based)
 - 01/16/2012 (Month First)
 - 16/01/2012 (Day First)
 - 2012/01/16 (Year First)
8. Press **SAVE**.

Using the Keyword Search Tab

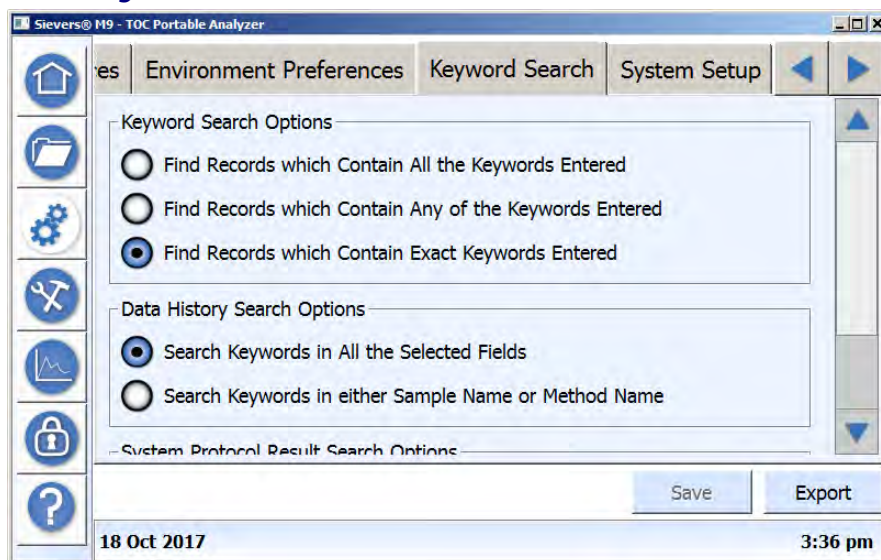



Figure 33: The Keyword Search Tab

Select parameter options for the keyword search that is accessed through the *Data History* tab on the *Configuration* screen. Select whether to search ALL selected fields, or only the *Sample Name* or *Method Name* field.

To set keyword search options

1. On the *Configuration*  screen, select the *Keyword Search* tab.
2. Select one of the following *Keyword Search Options*
 - Find Records which Contain All the Keywords Entered
 - Find Records which Contain Any of the Keywords Entered
 - Find Records which Contain Exact Keywords Entered
3. Select one of the following *Data History Search Options*
 - Search Keywords in All the Selected Fields
 - Search Keywords in either Sample Name or Method Name
4. Select one of the following *System Protocol Result Search Options*
 - Search Keywords in All the Selected Fields
 - Search Keywords in either Protocol Name or Vial Name
5. Press **SAVE**.

Using the System Setup Tab

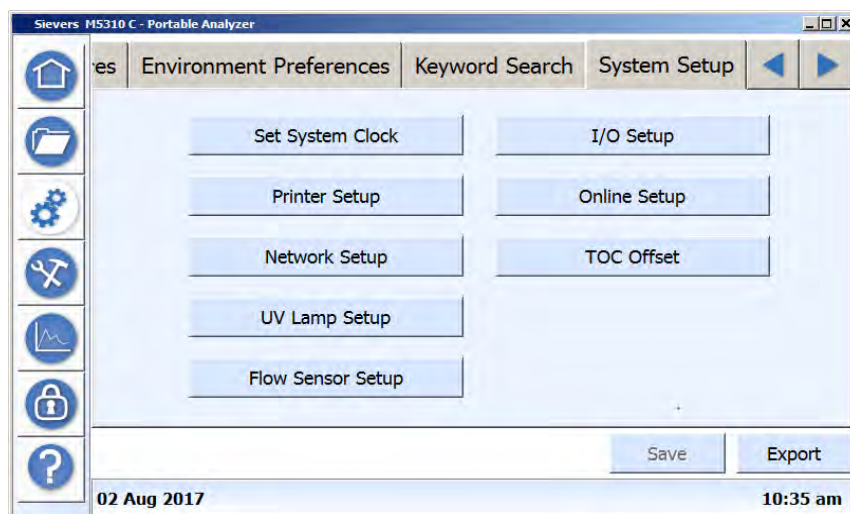

Use the following buttons on this screen:

- **SET SYSTEM CLOCK** — See [“Setting the System Clock” on page 125](#).
- **PRINTER SETUP** — See [“Configuring Printer Setup” on page 126](#).
- **NETWORK SETUP** — See [“Configuring the Network Connection” on page 126](#).
- **UV LAMP SETUP** — See [“Turning off the UV Lamp” on page 127](#).
- **FLOW SENSOR SETUP** — See [“Configuring Flow Sensors” on page 128](#).
- **I/O SETUP** (Sievers On-Line and Portable TOC Analyzers Only) — See [“Configuring I/O Setup” on page 129](#).
- **ONLINE SETUP** — See [“Configuring Online Setup” on page 129](#).
- **TOC OFFSET** — See [“To manually set the TOC Offset” on page 238](#).

Setting the System Clock

Use this procedure to set the date and time for the system clock.

To set the system clock

1. On the *Configuration*  screen, select the *System Setup* tab.
2. Press **SET SYSTEM CLOCK**. The *Set System clock* dialog box appears.

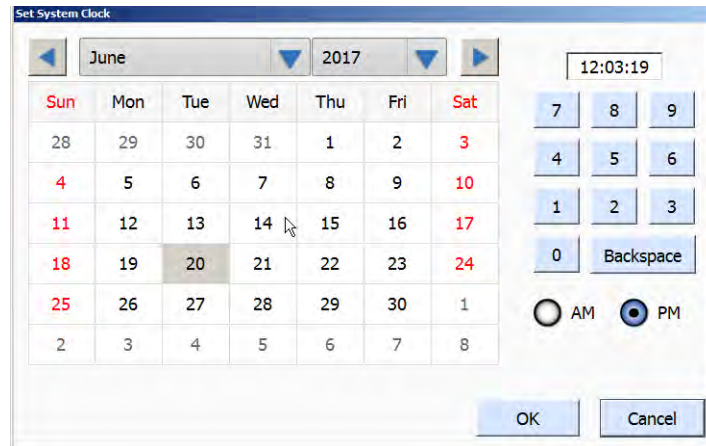

3. Using the calendar, set today's current date.
4. Using the numeric keypad to the right, set the current time and select either the **AM** or **PM** option.
5. Press **OK** to accept the settings and return to the *System Setup* tab.

Configuring Printer Setup

See [“Set Up the Printer \(Optional\)” on page 80](#).

Configuring the Network Connection

After connecting the Analyzer to a network via Ethernet (as described in [“Installing an Ethernet Connection” on page 68](#)), use this procedure to configure the network connection on the Analyzer.

To configure the network connection



NOTE: You may need assistance from your network administrator or Information Technology (IT) department to set the IP address correctly for your network.

1. Confirm that an active Ethernet cable is connected to the Analyzer.
2. On the **CONFIGURATION**  screen, select the *System Setup* tab.

- Press **NETWORK SETUP** to display the *Network Configuration* dialog box.



- Select **ENABLE NETWORK**.
- To use a dynamic IP address, select **Automatic** and press **OK**. Go to step 7.
- To use a fixed IP address, select **MANUAL**.
- Enter the IP and net mask addresses. Press inside each field to display the numeric keypad. Use the keypad to enter the appropriate number and press **OK**. The new number appears in the individual field.
- After you have entered the full IP Address and Net Mask addresses, press **OK**. A confirmation message appears.

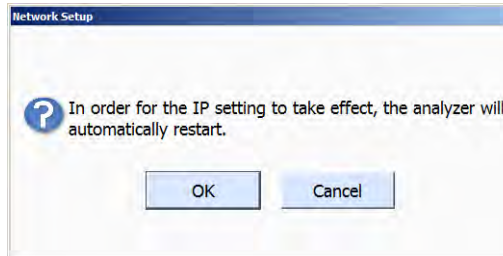

- Press **OK** to confirm the restart. The Analyzer automatically shuts down and restarts in order to implement the new IP setting.

Turning off the UV Lamp

Use this procedure to temporarily disable the UV lamp.

To temporarily turn off the UV lamp

- On the **CONFIGURATION**  screen, select the *System Setup* tab.
- To disable the UV lamp during analysis, press **UV LAMP SETUP**. The *UV Lamp Setup* dialog box appears.
- Select the *Turn off UV Lamp During Analysis* option and press **OK**.

Configuring Flow Sensors

Use the *System Setup* tab dialog box to disable one or more flow sensors, including the TC, IC, and iOS flow sensors. For applications that expect sample flow to stop, use the option for enabling the automatic restart of analysis.

There is also an option for setting a delay for the message notification after the Analyzer detects no flow. For Analyzers configured with I/O output and alarms, there are options for enabling the flow alarm and continuing analysis.

To configure the flow sensors

(Portable and On-Line TOC Analyzers Only)

1. On the **CONFIGURATION**  screen, select the *System Setup* tab.
2. Press **FLOW SENSOR SETUP**. The *Flow Sensor Setup* dialog box appears.

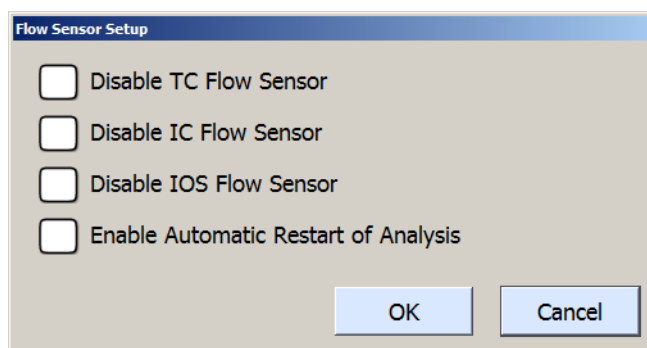

NOTE: Deselected flow sensor options are **enabled**.

3. To disable one or more flow sensors, select one or more of the following options:
 - *Disable TC Flow Sensor*
 - *Disable IC Flow Sensor*
 - *Disable iOS Flow Sensor*
4. Select the *Enable Automatic Restart of Analysis*. (This option applies to all sensors.)
5. Press **OK**.

Configuring I/O Setup

(Sievers On-Line and Portable TOC Analyzers Only)

This screen contains the following tabs:

- 4-20 mA Calibration
- 4-20 mA Output
- Binary Input (Start/Stop)
- Alarm Output

4-20 mA Calibration TAB

Use the *4-20 mA Calibration* tab for setting calibration values. Refer to [“To set up the Data I/O” on page 83](#) for step-by-step instructions.

4-20 mA Output TAB

Use the *4-20 mA Output* tab for configuring 4-20 mA outputs. Refer to [“To set up the Data I/O” on page 83](#) for step-by-step instructions.

Binary Input (Start/Stop) TAB

Use the *Binary Input (Start/Stop)* tab for configuring binary input (start/stop). Refer to [“To enable Binary Input \(start/stop\)” on page 84](#) for step-by-step instructions.

Alarm Output TAB

Use the *Alarm Output* tab for configuring alarm output. Refer to [“To configure the alarms” on page 84](#) for step-by-step instructions.

Configuring Online Setup

1. On the *Configuration*  screen, press the *System Setup* tab.
2. Press **ONLINE SETUP**. The *Online Setup* dialog box appears.

Chapter 4 OPERATION

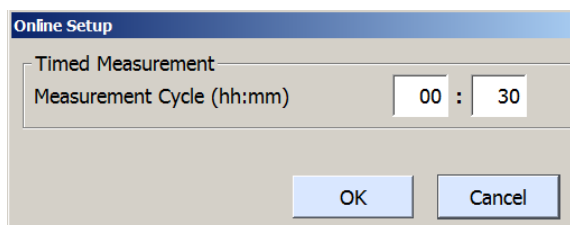

Online Setup Dialog Box — One-Stream Analyzer

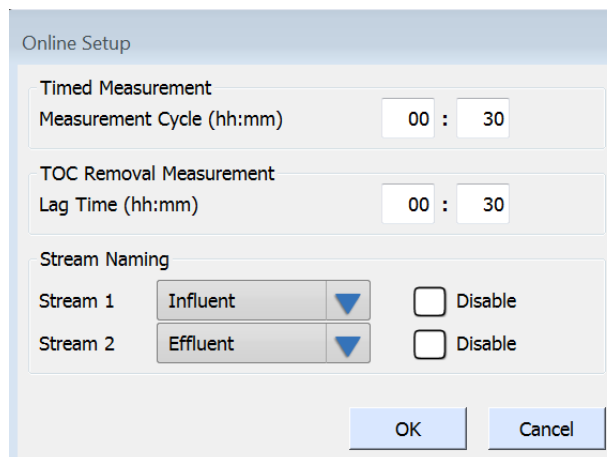

Online Setup Dialog Box — Two-Stream

3. In the *Timed Measurement* section, set the Measurement cycle in (hh:mm) for the Analyzer to repetitively take measurements on a stream.
4. (Optional for a two-stream Analyzer) Set *Stream 1* and *Stream 2* as either **Influent** or **Effluent**.



NOTE: The starting stream is the stream set as the Influent.

5. (Optional for a two-stream Analyzer) Select the *Disable* option for a stream, if applicable.
6. Press **OK** to save.

Manually setting the TOC Offset

See [“To manually set the TOC Offset” on page 238](#).

THE MAINTENANCE SCREEN

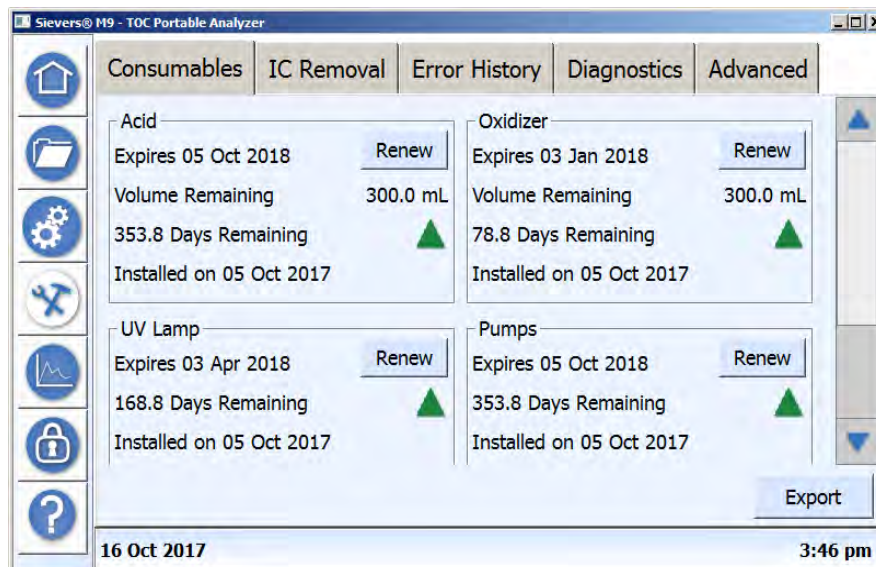

Figure 34: The Maintenance Screen

Overview of the Maintenance Screen

Use the *Maintenance* screen to review consumables status and to perform some advanced and miscellaneous Analyzer functions, including:

THE CONSUMABLES TAB

Use this tab to monitor remaining levels of consumables as described in [“Reviewing Consumables Status” on page 133](#).

THE IC REMOVAL TAB

Use this tab to monitor remaining levels of consumables as described in [“Reviewing IC Removal Consumables Status” on page 134](#).

THE ERROR HISTORY TAB

Use this tab to review the list of errors and warnings issued by the Analyzer during operation of the instrument. See [Chapter 8, “Reviewing Errors and Warnings.”](#)

Chapter 4 OPERATION

THE DIAGNOSTICS TAB

Perform diagnostic functions to create data files to send to Technical Support or your local service provider when troubleshooting operational and analysis issues. See [Chapter 8, "Using the Diagnostics Tab."](#)

THE ADVANCED TAB

This tab includes the following buttons for additional maintenance activities.

- **CLEAN SCREEN** — See ["Cleaning the Analyzer" on page 134.](#)
- **UPGRADE FIRMWARE** — See ["Upgrading Firmware" on page 135.](#)
- **ARCHIVE DATABASE** — See ["Viewing Archive Files" on page 136.](#)
- **BACKUP DATABASE** — See ["Backing Up the Database" on page 135.](#)
- **SYRINGE FLUSH** — See ["Performing a Syringe Flush" on page 136.](#)
- **ARCHIVE VIEWER** — See ["Viewing Archive Files" on page 136.](#)
- **RESTORE DATABASE** — See ["Restoring the Database" on page 137.](#)

Also included on this tab is a button for troubleshooting connection problems to DataPro2 or the Sievers Autosampler.

AUTOSAMPLER CONNECTION — See [Chapter 8, "Connection Problems to DataPro2 Software and Sievers Autosampler."](#)

THE SETTINGS TAB

Use this tab to create system settings on a primary instrument and propagate the settings to other instruments, to copy and restore system settings, and to reset offset values to factory default values.

- **CREATE MASTER SETTINGS** — See ["Creating Master Settings" on page 138.](#)
- **LOAD MASTER SETTINGS** — See ["Loading Master Settings" on page 138.](#)
- **BACKUP SETTINGS** — See ["Backing Up Settings" on page 138.](#)
- **RESTORE SETTINGS** — See ["Restoring Settings" on page 139.](#)
- **RESET SETTINGS** — See ["Resetting Offset Default Values" on page 140.](#)

Reviewing Consumables Status

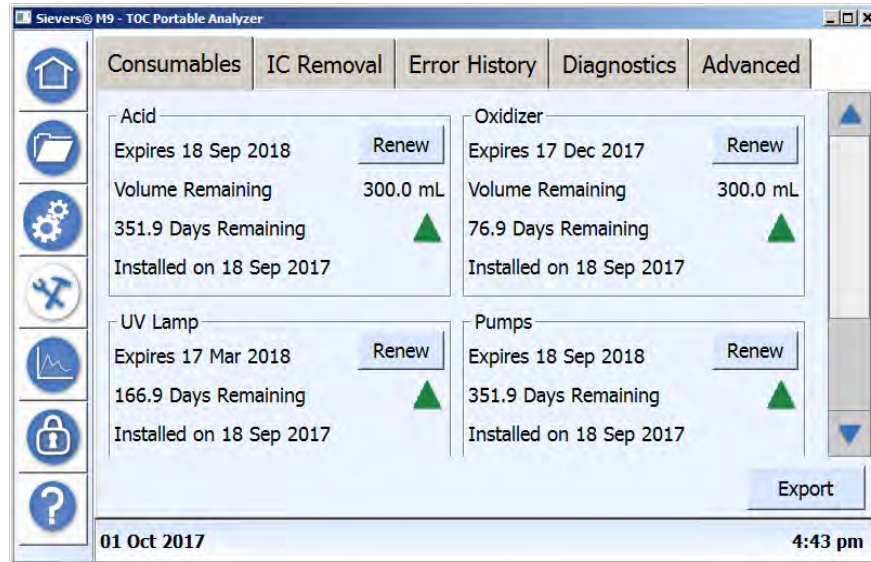



Figure 35: The Consumables Tab

Use the *Consumables* tab to monitor remaining consumables' levels for each of the Analyzer's consumables: Acid, Oxidizer, UV lamp, (sample) pumps, and resin cartridge. Volume, expiration dates, days remaining, and installation dates are listed for each consumable item. For information on replacing consumables, see [Chapter 7. "Maintenance."](#)

See another quick view of remaining consumables levels on the *Home*  screen. Press any of the consumable status bars and this *Consumables* tab appears.

Reviewing IC Removal Consumables Status

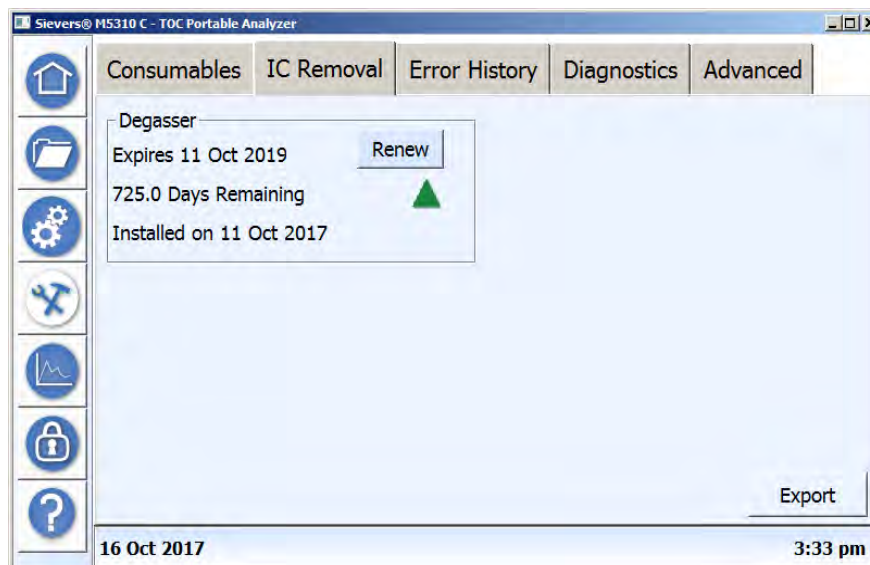

Figure 36: The IC Removal Tab

Use the *IC Removal* tab to monitor expiration information for the degasser.

Cleaning the Analyzer

This section includes suggested cleaning supplies and instructions for cleaning the Analyzer's external housing and touchscreen.

To clean the external housing

You will need a clean, soft cloth dampened with water or a non-abrasive cleaner, and another clean, *dry* soft cloth.

1. Shut down and turn *off* power to the Analyzer, then disconnect it from the main power source.
2. Wipe the external housing with a clean cloth dampened with water or a non-abrasive cleaner.
3. Wipe dry with another clean, *dry* soft cloth.

To clean the touchscreen

You will need a clean, soft (and *dry*) cloth or cotton pad.

1. Disable the screen for cleaning. On the *Maintenance*  screen, select the *Advanced* tab.
2. Press **CLEAN SCREEN** to temporarily disable the screen for 30 seconds. Repeat, as needed, if the 30-second time frame expires while cleaning.
3. Wipe the touchscreen with a clean, soft (and dry) cloth or cotton pad.

Upgrading Firmware

Use this instruction to install firmware updates.

To upgrade firmware

1. On the *Maintenance*  screen, select the *Advanced* tab.
2. Insert the USB memory drive with the firmware update into one of the *Host* USB ports on the Analyzer.
3. Press **UPGRADE FIRMWARE**. The Analyzer first performs an automatic backup and restore of system settings, and then processes the firmware update.
4. Upon receiving a message that the upgrade is complete, shut down and restart the Analyzer.

Archiving the Database

Use this feature to remove the database from the Analyzer and move/save it to a USB memory drive.

To archive the database

1. On the *Maintenance*  screen, select the *Advanced* tab.
2. Insert a USB memory drive into one of the *Host* USB ports on the Analyzer.
3. Press **ARCHIVE DATABASE**. The Analyzer shows the status of the process.
4. When the Analyzer indicates the process is complete, press **CLOSE**.
5. Remove the USB memory drive.

Backing Up the Database

Use this instruction to make a copy of the database to a USB memory drive for any future restoration needs. The database remains active in the Analyzer.

Chapter 4 OPERATION

To back up the database

1. On the *Maintenance*  screen, select the *Advanced* tab.
2. Insert a USB memory drive into one of the *Host* USB ports on the Analyzer.
3. Press **BACKUP DATABASE**. The Analyzer shows the status of the process.
4. When the Analyzer indicates the process is complete, press **CLOSE**.
5. Remove the USB memory drive.

Performing a Syringe Flush

Use this instruction to perform a syringe flush.

To perform a syringe flush

1. On the *Maintenance*  screen, select the *Advanced* tab.
2. Press **SYRINGE FLUSH**. The Analyzer shows the status of the process.
3. When the Analyzer indicates the process is complete, press **CLOSE**.

Viewing Archive Files

Use this instruction to view content that has been moved to an archive file.

To view an archive file

1. On the *Maintenance*  screen, select the *Advanced* tab.
2. Insert the USB memory drive with the Archived Database files into one of the *Host* USB ports on the Analyzer.
3. Press **ARCHIVE VIEWER**. The *Select an Archived File* dialog box appears.



4. Select an archive file from the list and press **OK** to load and view the content. The *Archive Viewer* screen appears.

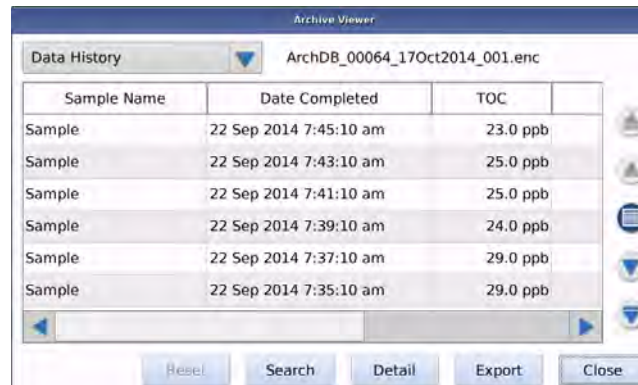

5. Select one of the following from the list located at the left of the name of the archive file:
 - Data History
 - Calibration History
 - Verification History
 - Validation History
 - Error History
6. Use the up and down arrows to view additional records.
7. Select a record and press **DETAIL** for additional information.
8. Press **SEARCH**, or press the calendar  icon, to define a range of records to display.
9. Insert a USB memory drive and press **EXPORT** to export data as viewed.
10. Press **CLOSE** and remove the USB memory drive.

Restoring the Database

To restore the database

1. On the *Maintenance*  screen, select the *Advanced* tab.
2. Insert the USB memory drive with the backup database into one of the *Host* USB ports on the Analyzer.
3. Press **RESTORE DATABASE**.
4. Click **YES** to proceed. The current database is backed up prior to restoring the database. Or, click **No** to cancel.
5. When the Analyzer indicates the process is complete, press **CLOSE**.
6. Remove the USB memory drive.

Creating Master Settings

Use this feature to create a file containing the system settings on a primary instrument. You can use the file to propagate those system settings to other instruments.

To create master settings

1. On the *Maintenance*  screen, select the *Settings* tab.
2. Insert a USB memory drive into one of the *Host* USB ports on the Analyzer.
3. Press **CREATE MASTER SETTINGS**.
4. When the Analyzer indicates the process is complete, press **CLOSE**.
5. Remove the USB memory drive.

Loading Master Settings

After you have created a file containing the system settings on a primary instrument, use this instruction to load the system settings onto other instruments.

To load master settings

1. On the *Maintenance*  screen, select the *Settings* tab.
2. Insert the USB memory drive with the system settings saved on the primary instrument into one of the *Host* USB ports on the Analyzer.
3. Press **LOAD MASTER SETTINGS**.
4. When the Analyzer indicates the process is complete, press **CLOSE**.
5. Remove the USB memory drive.

Backing Up Settings

Use this instruction to make a copy of the system settings for later reference and/or to use for any needed troubleshooting or restore activities.

To back up settings

1. On the *Maintenance*  screen, select the *Settings* tab.
2. Insert a USB memory drive into one of the *Host* USB ports on the Analyzer.
3. Press **BACKUP SETTINGS**.

4. Select which settings to back up, including *System* or *Dual Conductivity*.
5. Press **CONTINUE** and the Analyzer begins the backup process. When the message indicates 100% completion, press **CLOSE**.
6. Remove the USB memory drive.

Restoring Settings

Use this instruction to restore system settings to the Analyzer from a USB memory drive containing previously saved system settings files.

To restore settings

1. On the *Maintenance*  screen, select the *Settings* tab.
2. Insert the USB memory drive with the saved Analyzer settings into one of the *Host* USB ports on the Analyzer.
3. Press **RESTORE SETTINGS**. A confirmation message appears.
4. Review the message and press **YES** to confirm. The *Restore System Settings* dialog box appears.

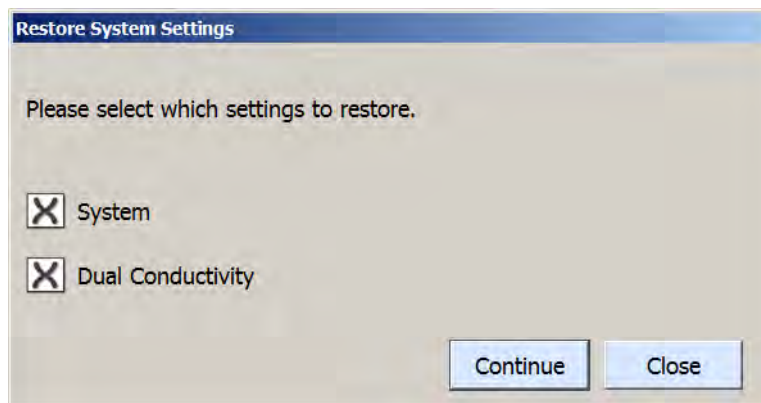

5. Select one or more of the following:
 - System
 - Dual Conductivity (restore settings on the TC/IC electronics board)
6. Press **CONTINUE** or press **CLOSE** to return to the *Advanced* tab. The Analyzer shows the status of the process on the *Restore System Settings* dialog box.
7. When the Analyzer indicates the process is complete and that it is safe to remove the USB memory drive, remove it.
8. Press **RESTART** to automatically restart the Analyzer.

Chapter 4 OPERATION

Resetting Offset Default Values

Use this instruction to reset the TOC Offset setting to the factory-default value.

1. On the *Maintenance*  screen, select the *Settings* tab.
2. Press **RESET SETTINGS**. The *Reset System Settings* dialog box appears.
3. Select the *TOC Offset* option.
4. Press **RESET**. A confirmation message appears to verify resetting to the factory default value.
5. Press **YES** to confirm and return to the *Reset System Settings* dialog box.
6. Press **CLOSE** to return to the *Advanced* tab menu.

THE DATA VIEW SCREEN



The data for sample analyses is located on the *Data View* screen (*Municipal Test History* tab). View various levels of detail and export data, as needed.

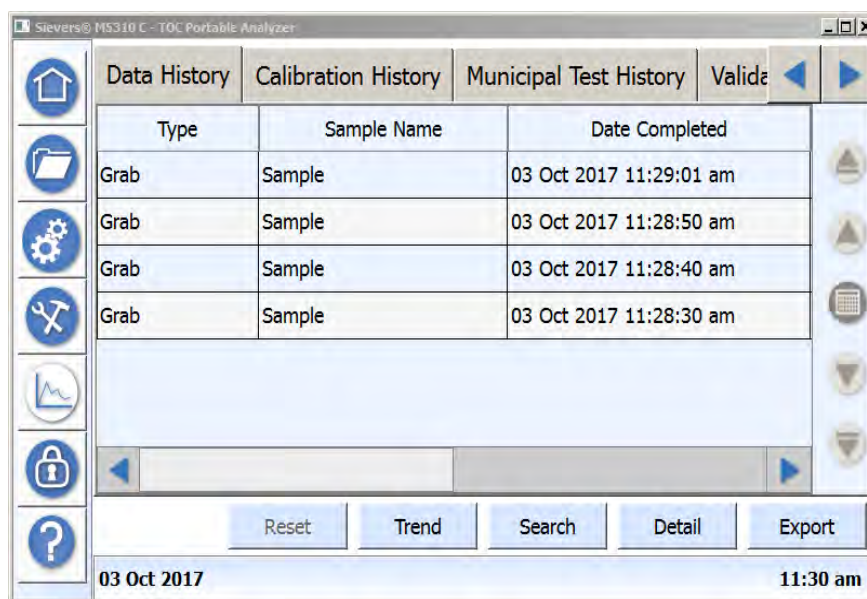



The screenshot shows the 'Data History' tab of the Sievers M5310 C TOC Portable Analyzer. The interface includes a navigation menu on the left with icons for Home, Folder, Settings, Wrench, Graph, Lock, and Help. The main area displays a table with columns for Type, Sample Name, and Date Completed. Below the table are buttons for Reset, Trend, Search, Detail, and Export. The status bar at the bottom shows the date 03 Oct 2017 and the time 11:30 am.

Type	Sample Name	Date Completed
Grab	Sample	03 Oct 2017 11:29:01 am
Grab	Sample	03 Oct 2017 11:28:50 am
Grab	Sample	03 Oct 2017 11:28:40 am
Grab	Sample	03 Oct 2017 11:28:30 am

Figure 37: The Data History Tab

To view data history

1. On the *Data View*  screen, select one of the following tabs:
 - Data History
 - Calibration History
 - Municipal Test History
 - Validation History
2. Use the horizontal scroll bar and the *up* and *down* arrows to scroll through the list, as needed. To search by date, press the calendar  icon. Or, to search for a specific protocol, press **SEARCH**, enter search criteria, and press **SEARCH**.
3. Select the line for the analysis and press **DETAIL** to view additional information. The *Detail* dialog box appears displaying the Protocol description.

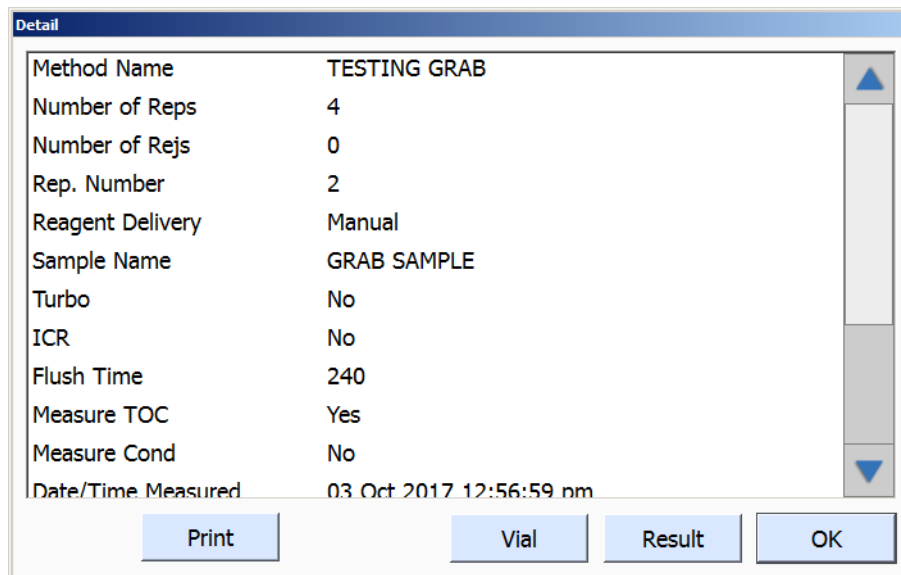

Detail	
Method Name	TESTING GRAB
Number of Reps	4
Number of Rejs	0
Rep. Number	2
Reagent Delivery	Manual
Sample Name	GRAB SAMPLE
Turbo	No
ICR	No
Flush Time	240
Measure TOC	Yes
Measure Cond	No
Date/Time Measured	03 Oct 2017 12:56:59 pm

Buttons: Print, Vial, Result, OK



NOTE: The available buttons vary on each tab according to the type of sample analysis.

4. Press **VIAL** (*Data History* tab only) to view a summary of the sampling method.
5. Press **RESULT** to return to the details of the sampling method.
6. Press **PRINT** to print the details.
7. Press **PROTOCOL** (*Calibration History*, *Verification History*, and *Validation History* tabs only) to return to the Protocol description.
8. When finished viewing the data, press **OK** to return to the tab view.

Chapter 4 OPERATION

9. To view a trend graph of the sampling results, press **TREND**.
10. To search for a particular sampling result, press **SEARCH**. The *Search Result Criteria* dialog box appears. Enter criteria information and press **SEARCH**.
11. To export the data, insert a USB memory drive into one of the USB host ports. Select the protocol line and press **EXPORT**.

THE SECURITY SCREEN

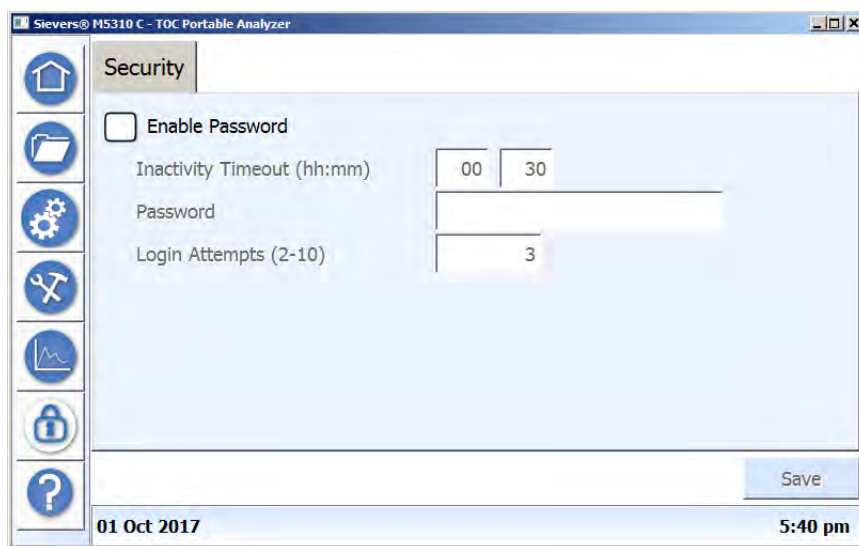

Figure 38: Password Protection Screen

Use this screen to configure Password Protection. Refer to [Chapter 5. "Password Protection"](#) for step-by-step instructions.

THE HELP SCREEN

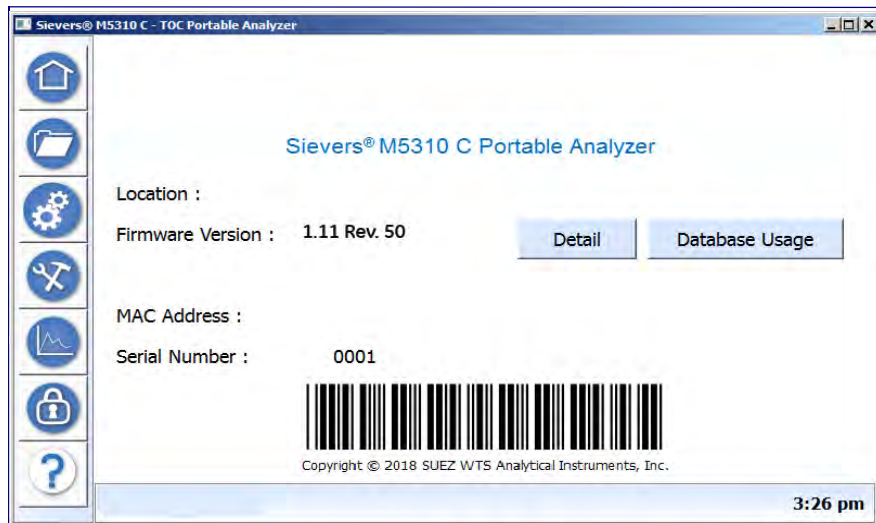

Figure 39: The Help Screen

Refer to this screen to confirm Analyzer *Location*, *Firmware Version*, *IP Address*, *MAC Address*, and Analyzer *Serial Number*. The bar code also contains identifying information. Press **DETAILS** to display the *Firmware Version*, *Supported DataPro2 Versions*, and *Installed ICR Type*. Press **DATABASE USAGE** to display a list of the database tables showing the remaining available records for each.



NOTE: A warning appears when database tables (such as the *User* or *Protocol* database tables) are at 75%, 90%, 95% and 99% full. An error appears when the table is full.

THIS PAGE IS INTENTIONALLY LEFT BLANK.

5

PASSWORD PROTECTION

OVERVIEW

The Password Protection feature is included with all Analyzers and provides a basic level of security. Password Protection allows for the use of one User ID and password, which users are required to enter before starting and stopping analysis or gaining access to menu screens.

USING PASSWORD PROTECTION

To ensure that only authorized personnel access the Analyzer, assign one User ID and password that all users must enter before starting and stopping analysis or gaining access to menu screens.

Enabling Password Protection

The same User ID and password will be required by all users. Any user using this ID and password can change the password, as needed, to comply with internal security policies.

Chapter 5 PASSWORD PROTECTION

To enable or disable Password Protection

1. On the *Security*  screen, select the *Security* tab.

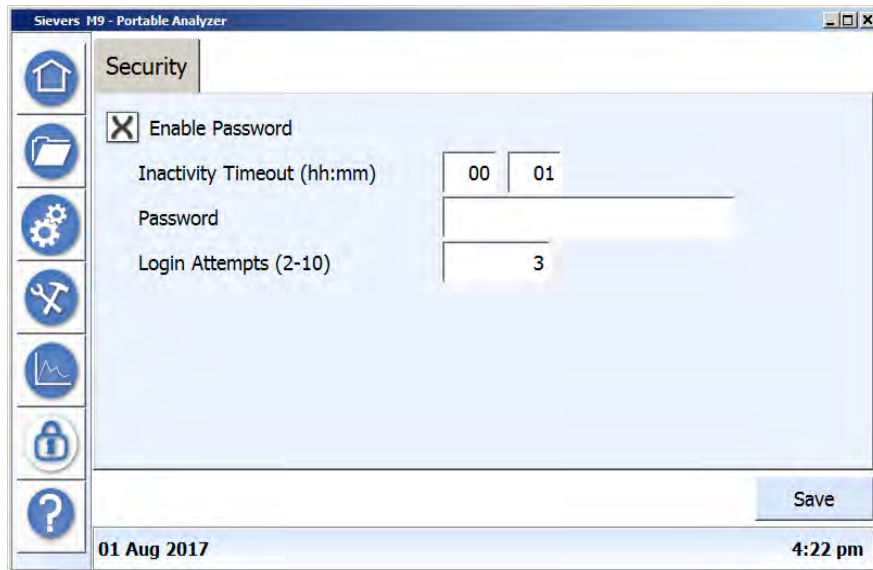

2. Select the *Enable Password* option.
3. Complete the following:
 - Inactivity Timeout (hours and minutes) The minimum timeout is one (1) minute.
 - Login Attempts (2-10)
4. Press the *Password* field and use the alpha numeric keypad to enter a password.
5. Press **SAVE**.

To log in using Password Protection

1. Power on the Analyzer. The *Home* screen appears.
2. Press any screen icon. The *Login* dialog box appears.

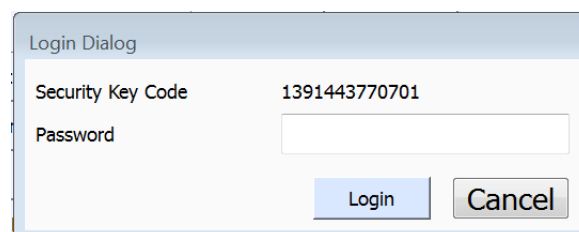

3. Press the *Password* field and use the alpha numeric keypad to enter the password.
4. Press **LOGIN**.

To change the password

1. On the *Security*  screen, select the *Security* tab.

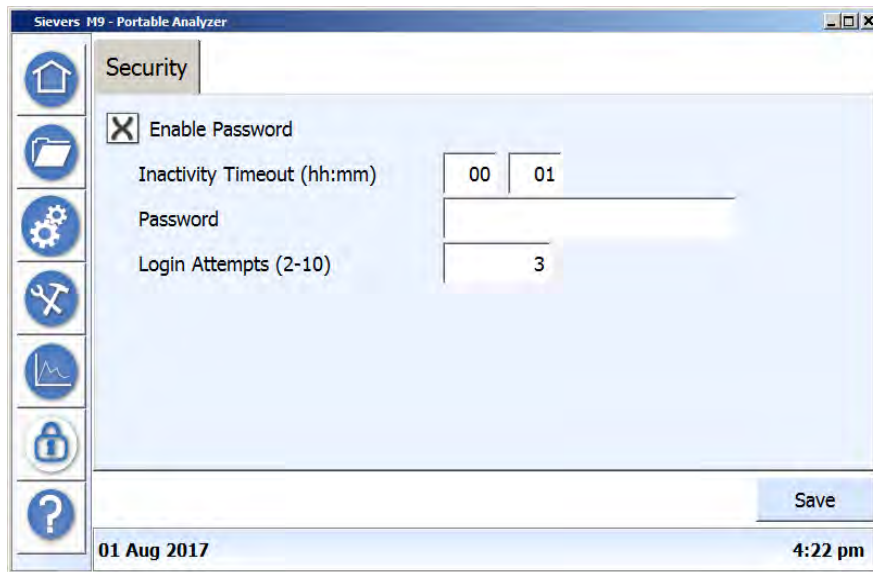

2. Press the *Password* field and use the alpha numeric keypad to enter a new password.
3. Press **SAVE**. The previous password will be overwritten.

THIS PAGE IS INTENTIONALLY LEFT BLANK.

6

CALIBRATION

OVERVIEW

This chapter describes the calibration and verification procedures for Analyzers running in *On-Line* or stand-alone *Grab* mode without the use of a Sievers Autosampler.



NOTE: *If your configuration includes the use of a Sievers Autosampler, refer to the calibration instructions in the Datapro2 Software User Guide instead of using the instructions in this chapter.*

The Analyzer is calibrated at the factory and requires annual recalibration. Perform a calibration verification when replacing components that affect analysis, such as the UV lamp.

Calibration and verification involve using Sievers Standards in vials sampled via the Analyzer's iOS System (*Sievers On-Line and Portable TOC Analyzers*) or vial port (*Sievers Laboratory TOC Analyzer*). The Sievers M5310 C TOC Analyzer facilitates the calibration and verification process with automatic calculations. You will then have the opportunity to apply or not apply the calibration at the end of the procedure.

Calibrate the Sievers M5310 C TOC Analyzer using **either** the Single-Point Calibration (at 1, 5, 10, 25 or 50 ppm) **or** a Multi-Point Calibration (at 0.25, 1, 5, 10, 25, and 50 ppm). **Do not perform both types** of calibration as the Analyzer only stores the last applied calibration. A Single-Point Calibration requires approximately one hour to complete and the Multi-Point Calibration requires approximately two hours.

SUEZ recommends calibrating the Analyzer using the Single-Point Calibration at a concentration above the range of interest. For customers typically operating below 1 ppm, SUEZ recommends selecting the 1 ppm Single-Point Calibration. Multi-Point Calibration calibrates the Analyzer over its entire operating range, and is available as an alternate procedure.



NOTE: Screenshots in this chapter show the Sievers M9 Portable TOC Analyzer firmware. However, the functionality is the same for all models, unless specifically noted.

Using the Autoreagent Verification

Do an autoreagent verification at x-interval amount of time when using the autoreagent feature. Use the autoreagent feature when concentration in the sample is not known. (See [“To perform an Autoreagent Verification” on page 171.](#))

REQUIRED CALIBRATION SUPPLIES

To ensure accurate results, ALWAYS use Sievers Standards for all calibration and verification procedures. Standards sets for calibration and verification can be purchased individually or as combined Calibration & Verification Sets. Standards for use in the Analyzer are provided in 40-mL vials.

To Order

To order standards, contact Customer Care or your local service provider.

DI Water for Syringe Flush

If a reagent syringe flush has not been performed in eight hours previous to performing a calibration, the Analyzer will prompt you to perform one. For on-line configurations, this requires access to a continuous water supply (or a 40-mL vial of DI water). If the Analyzer is configured for Grab mode, one 40-mL vial DI water is needed for a reagent syringe flush prior to calibration.

REQUIRED STANDARDS LISTS

This section details what standards are required for each system protocol. Contact Customer Care or your local service provider to request our *Reference Standards Parts List* or *Sievers Certified Reference Materials and Consumables Catalog* to order the correct standards for your instrument.



NOTE: 1 ppm = 1 mg C/L, 1 ppb = 1 µg C/L

Standards Required for Single-Point Calibration

Purchase Sievers Single-Point Calibration standards in a concentration that is appropriate for your application. Sets include one vial of reagent water and one vial each of TOC and IC in the selected concentration.

TABLE 8: STANDARDS REQUIRED FOR SINGLE-POINT CALIBRATION

<i>TOC Calibration Standards</i>
Calibration Blank
1, 5, 10, 25, or 50 ppm TOC (as KHP)
<i>IC Calibration Standards</i>
1, 5, 10, 25, or 50 ppm IC (as Na ₂ CO ₃)

Standards Required for Multi-Point Calibration

Sievers Multi-Point Calibration sets include all the TOC and IC standards shown in Table 9.

TABLE 9: STANDARDS REQUIRED FOR MULTI-POINT CALIBRATION

<i>TOC Calibration Standards</i>
Calibration Blank
250 ppb TOC (as KHP)
1 ppm TOC (as KHP)
5 ppm TOC (as KHP)
10 ppm TOC (as KHP)
25 ppm TOC (as KHP)
50 ppm TOC (as KHP)
<i>IC Calibration Standards</i>
10 ppm IC (as Na ₂ CO ₃)

Standards Required for Single-Point Verification

Purchase Verification standards in a concentration that is appropriate for your application. Sets include one vial of reagent water blank and one vial each of TOC and IC in the selected concentration. The available concentrations are shown in Table 10.

TABLE 10: STANDARDS REQUIRED FOR SINGLE-POINT VERIFICATION

<i>TOC Verification Standards</i>
Verification Blank
500 ppb or 1, 2, 5, 10, 25, or 50 ppm TOC (as sucrose)
<i>IC Verification Standards</i>
500 ppb or 1, 2, 5, 10, 25, or 50 ppm IC (as Na ₂ CO ₃)

Standards Required for Autoreagent Verification

Autoreagent verification standards sets include the standards shown in Table 11.

TABLE 11: STANDARDS REQUIRED FOR AUTOREAGENT VERIFICATION

<i>Autoreagent Verification Standards</i>
10 ppm TOC (as sucrose)
25 ppm TOC (as sucrose)

PREPARING FOR CALIBRATION

Before calibrating the Analyzer, back up the database and system settings (constants). For annual calibrations, also perform annual maintenance tasks. Additionally, if the Analyzer is used online with water less than 50 ppb TOC, perform a TOC Autozero ([page 155](#)).

Backing Up the Database

Prior to performing any calibration procedure, back up the database to save a copy of the Analyzer's data.

To back up the database

1. On the *Maintenance*  screen, press the *Advanced* tab.



2. Insert a USB memory drive into one of the USB host ports.
3. Press **BACKUP DATABASE**. The Analyzer begins the backup process. When the message indicates 100% completion, press **CLOSE**.

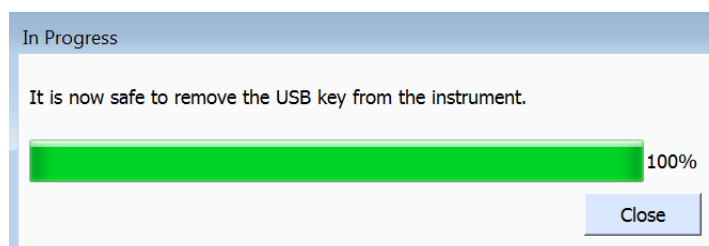

4. Remove the USB memory drive and store for safekeeping.

Backing Up Settings (Constants)

Prior to performing any calibration procedure, save the system settings (constants).

To back up system settings (constants)

1. On the *Maintenance*  screen, select the *Settings* tab.
2. Insert a USB memory drive into one of the USB host ports.

Chapter 6 CALIBRATION

3. Press **BACKUP SETTINGS**.
4. Select which settings to back up, including *System* or *Dual Conductivity*.
5. Press **CONTINUE** and the Analyzer begins the backup process. When the message indicates 100% completion, press **CLOSE**.

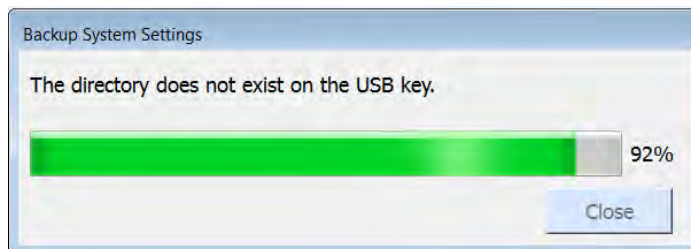

6. Remove the USB memory drive and store for safekeeping.

Performing Annual Maintenance Tasks

Before an annual Analyzer calibration, replace consumables as appropriate, such as the sample pump heads, UV lamp, chemical reagents, and resin bed. Refer to the Chapter 7, "Maintenance" for step-by-step instructions.

Performing a TOC Autozero (optional)

Only perform this procedure before calibrating the Analyzer if regularly analyzing online samples with TOC <50 ppb. If using the Analyzer to analyze water that is >50 ppb or for grab samples using vials, there is no need to perform a TOC Autozero (unless instructed to do so by Technical Support or your local service provider). The optional TOC Autozero corrects for minor differences in the response of the two CO₂ sensors. This adjustment is critical only for the determination of low-level TOC concentrations.

(Optional On-Line Only) To enable scheduled TOC Autozero operations, select the TOC Autozero protocol and press **SETUP** to display the *TOC Autozero Setup* dialog box ([Figure 40](#)). Select the option and set the Frequency and Start Date and Time.

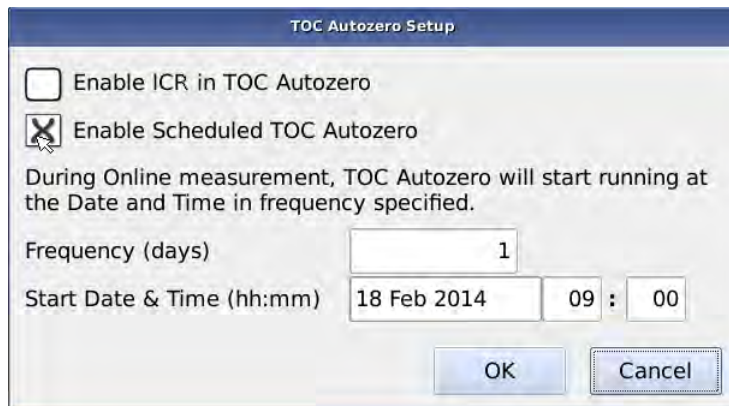

Figure 40: TOC Autozero Setup

To perform a TOC Autozero (optional)

1. If Password protection is enabled, log in to the Analyzer with the appropriate password.
2. Stop (*Home* screen) or cancel (*Protocols* screen) any current analysis.
3. For a *Grab* mode configuration, connect the Analyzer to a supply of (at least 1000 mL) low-TOC DI water. (Otherwise, go to step 6 for an on-line configuration).

Disconnect the stainless steel tubing that runs from the iOS system to the *Sample Inlet* port.

4. Attach the sipper tube (provided in the Accessories Kit) to the Analyzer's *Sample Inlet* port.
5. Insert the other end of the sipper tube into a large flask (at least 1000 mL) of low-TOC DI water.
6. For an on-line configuration, ensure that the Analyzer is connected to a DI water source.

Chapter 6 CALIBRATION

7. On the *Protocols* screen, select the *System Protocols* tab.

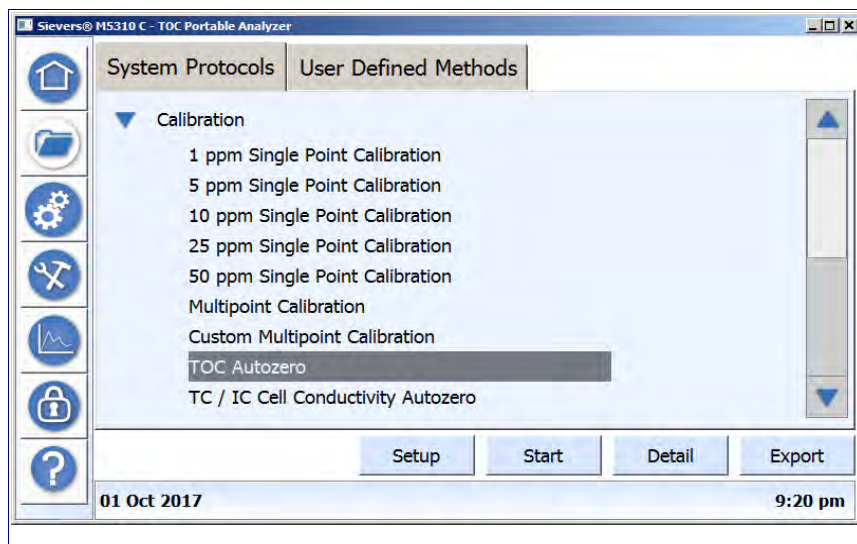

8. Select **TOC AUTOZERO**.
9. (Optional ICR Unit Only) If you want to run the TOC Autozero with the ICR enabled, press **SETUP**. The *TOC Autozero Setup* dialog box appears. See [Figure 40: TOC Autozero Setup on page 155](#).

Select the *Enable ICR in TOC Autozero* option, and press **OK**.



NOTE: The state of the ICR (online or offline) in an active user-defined method has no relation to running a TOC Autozero with the ICR enabled. Even if you are not using the ICR, you have the option to run TOC Autozeroes with the ICR enabled (in-line).

10. Press **START**.

The System Protocol: TOC Autozero dialog box appears.

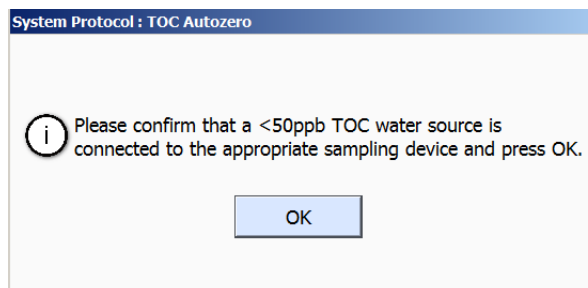

11. Confirm that an appropriate water source is connected and press **OK**. The Analyzer begins the TOC Autozero process and reports the number of minutes passing before it completes.
12. Wait for the TOC Autozero to complete and record its completion on the *Single-Point Calibration Worksheet*. Write **YES** to indicate that the TOC Autozero was completed.

13. If you changed your sample inlet configuration at the beginning of this procedure to a sipper tube connection, reconnect the stainless steel tubing to the *Sample Inlet* port.

SYSTEM PROTOCOLS

Worksheets for use in recording calibration and verification protocol results are provided in Appendix B, "Protocol Worksheets."

Performing a Single-Point Calibration for Grab/On-Line Operation

1.0 INTRODUCTION

Analyzer is calibrated at the factory to ensure accurate measurements and comes with a *Certificate of Calibration*. Thereafter, the Analyzer should require re-calibration only once per year. Perform this procedure to calibrate the Analyzer to factory specifications. This procedure uses a Single-Point of calibration as per the normal range of TOC measurement for your application.



NOTE: *It is **only** necessary to perform either a Single-Point calibration or a Multi-Point calibration, as the Analyzer only stores the last accepted calibration. Do not perform both types of calibration.*

2.0 SCOPE

This procedure applies to all Sievers M5310 C Analyzers operating in *Grab* or *On-Line* mode.

After completing this calibration, perform a Single-Point Verification to confirm that the calibration is accurate.

3.0 MATERIALS



NOTE: *Use **only** Sievers standards purchased from SUEZ.*

- 3.1 Sievers M5310 C Analyzer
- 3.2 *Single-Point Calibration for Grab/On-Line Worksheet*
- 3.3 Single-Point Calibration Standards Set
 - 3.3.1 One vial — Blank (Rw)

Chapter 6 CALIBRATION

- 3.3.2 One vial — 1 ppm, 5 ppm, 10 ppm, 25 ppm, or 50 ppm TOC (as KHP)
- 3.3.3 One vial — 1 ppm, 5 ppm, 10 ppm, 25 ppm, or 50 ppm IC (as Na₂CO₃)
- 3.3.4 (Optional, if performing a reagent/syringe flush) One vial — DI water.

4.0 DEFINITIONS

- 4.1 DI — DEIONIZED
- 4.2 TOC — TOTAL ORGANIC CARBON
- 4.3 TC — TOTAL CARBON
- 4.4 IC — INORGANIC CARBON

5.0 PROCEDURE

To perform a Single-Point Calibration

- 5.1 If Password protection is enabled, log in to the Analyzer with the appropriate password.
- 5.2 Stop (*Home* screen) or cancel (*System Protocols* screen) any current analysis.
- 5.3 Back up the database and settings for later reference.
 - 5.3.1 Insert a USB memory drive into one of the USB host ports and press the *Advanced* tab on the *Maintenance* screen.
 - 5.3.2 Press **BACKUP DATABASE**. The Analyzer begins the backup process.
 - 5.3.3 When the backup is complete, a message appears that it is safe to remove the USB memory drive. Leave the USB memory drive inserted and press **CLOSE**.
 - 5.3.4 Press the *Settings* tab on the *Maintenance* screen.
 - 5.3.5 Press **BACKUP SETTINGS**. Select which settings to back up, including *System* or *Dual Conductivity*.
 - 5.3.6 Press **CONTINUE** and the Analyzer begins the backup process. When the message indicates 100% completion, remove the USB memory drive and press **CLOSE**.
- 5.4 On the *Protocols*  screen, select the *System Protocols* tab.

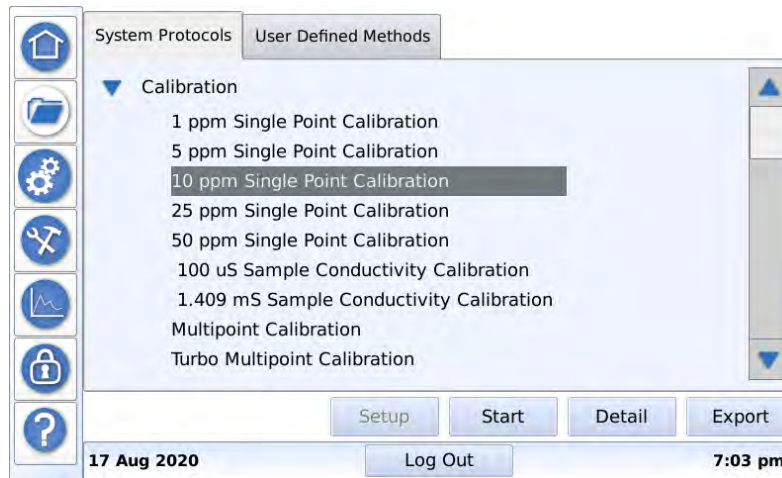

- 5.5 If regularly analyzing online samples with <50 ppb TOC, perform a TOC Autozero (as described in the *Analyzer's Operation and Maintenance Manual*).
- 5.6 Select the appropriate Single Point Calibration (1 ppm, 5 ppm, 10 ppm, 25 ppm, or 50 ppm). Press **START**. The *FSE Certification License* dialog box appears.

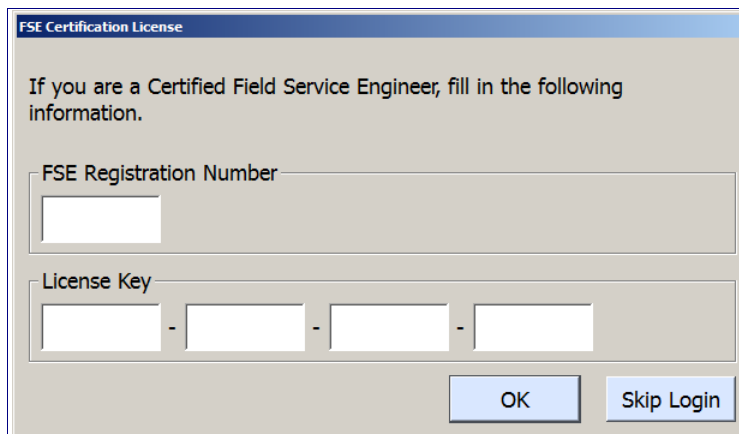

- 5.6.1 If you are a Certified Field Service Engineer, complete the fields and press **OK**. Otherwise, press **SKIP LOGIN**.
- 5.7 If the Analyzer has not been used during the last eight hours for a protocol that uses oxidizer (such as this one) and a reagent flush has not been

Chapter 6 CALIBRATION

performed, the *8 Hour Reagent Flush* message appears. Otherwise, go directly to step [5.9](#).

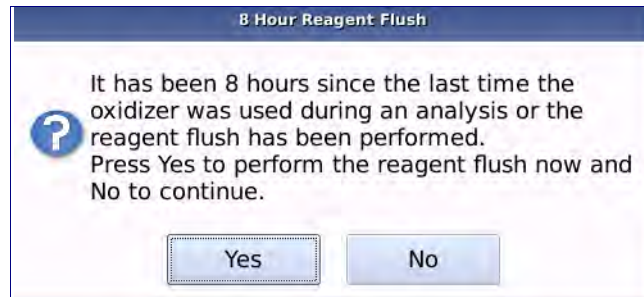

5.8 On the message dialog box, do one of the following:

- *To perform the suggested reagent flush* — Press **YES** to continue and display the *Connect Water Source* dialog box. Insert a 40 mL vial of low-TOC DI water into the iOS System (*On-Line or Portable Analyzer*) or Vial Port (*Laboratory Analyzer*) and press **OK**. The Syringe Flush dialog box appears while the Analyzer performs the flush. When the flush is complete, go to step [5.9](#).
- *To continue without performing a reagent flush* - Press **NO** and go to step [5.9](#).

5.9 The *System Protocol: Single Point Calibration* message appears. Insert the *Blank (Rw)* vial into the iOS or vial port and press **CONTINUE**. The sample analysis begins.

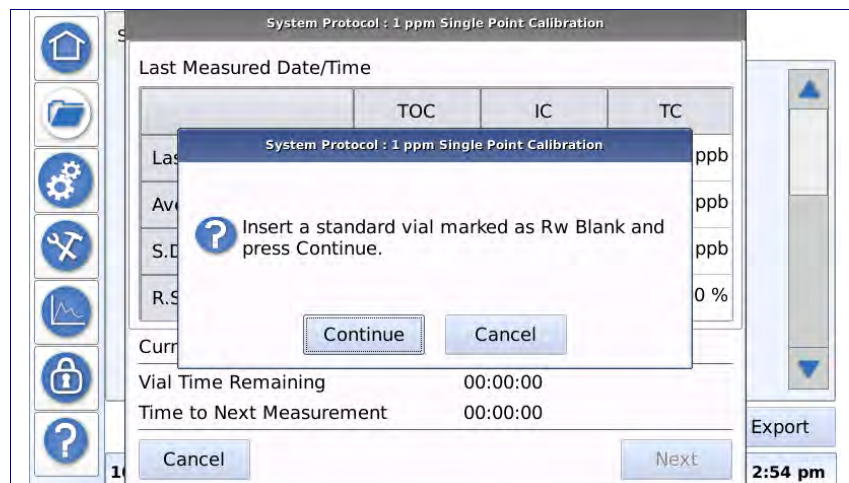

5.10 When the Analyzer completes the measurement, the **NEXT** button will flash.

5.11 Press **NEXT** and follow the Analyzer's instructions for the remaining vials.

5.12 When the Analyzer completes the measurements, the *Calibration Result* screen appears with the result data and indication if the *Calibration Passed* or *Calibration Failed*.

Calibration Result			
System Protocol : 10 ppm Single Point Calibration			Calibration Passed
	Rw Blank	10 ppm TOC	10 ppm IC
1	12.0ppb	9.96ppm	10.2ppm
2	13.0ppb	10.1ppm	10.2ppm
3	15.0ppb	9.96ppm	10.2ppm
Average	13.3ppb	10.0ppm	10.2ppm
RSD	11.5	0.81	0.00
Expected	N/A	10.0ppm	10.3ppm
% Diff	N/A	0.00	-0.97
Adjusted	12.8ppb	10.0ppm	10.3ppm
Result	N/A	Passed	Passed

5.13 Do one of the following:

- If the calibration passed, press **APPLY** to accept the calibration.
- If the calibration failed, leave the screen as is and contact Technical Support or your local service provider. Before calling, e-mail the backup and system settings files (created in advance of running calibration protocols). After analysis of the data, you may be advised to accept the results or to pursue additional troubleshooting steps.

5.14 To print or export the results, press the corresponding button.

5.15 Remove the last vial from the Analyzer.

Performing a Multi-Point Calibration for Grab/On-Line Operation

1.0 INTRODUCTION

The Analyzer is calibrated at the factory to ensure accurate measurements and comes with a *Certificate of Calibration*. Thereafter, the Analyzer should require re-calibration only once per year. Perform this procedure to calibrate the Analyzer to factory specifications.

This Multi-Point Calibration procedure calibrates the Analyzer over its entire operating range. The Multi-Point Calibration procedure is as an alternative to the recommended Single-Point Calibration procedure. SUEZ recommends performing the Multi-Point Calibration procedure prior to performing the Autoreagent Verification procedure.

Chapter 6 CALIBRATION



NOTE: It is **only** necessary to perform either a *Single-Point* calibration **or** a *Multi-Point* calibration, as the Analyzer only stores the last calibration performed and applied.

2.0 SCOPE

This procedure applies to all Sievers M5310 C Analyzers operating in *Grab* or *On-Line* mode.

After completing this calibration, perform a Single-Point Verification to confirm that the calibration is within specification.

3.0 MATERIALS



NOTE: Use **only** Sievers standards purchased from SUEZ.

- 3.1 Sievers M5310 C Analyzer
- 3.2 Multi-Point Calibration for Grab/On-Line Worksheet
- 3.3 Multi-Point Calibration Standards Set
 - 3.3.1 One vial — Blank (Rw)
 - 3.3.2 One vial — 250 ppb TOC (as KHP)
 - 3.3.3 One vial — 1 ppm TOC (as KHP)
 - 3.3.4 One vial — 5 ppm TOC (as KHP)
 - 3.3.5 One vial — 10 ppm TOC (as KHP)
 - 3.3.6 One vial — 25 ppm TOC (as KHP)
 - 3.3.7 One vial — 50 ppm TOC (as KHP)
 - 3.3.8 One vial — 10 ppm IC (as Na₂CO₃)
- 3.4 (Optional, if performing a reagent/syringe flush) One vial — DI water.

4.0 DEFINITIONS

- 4.1 DI — DEIONIZED
- 4.2 TOC — TOTAL ORGANIC CARBON
- 4.3 TC — TOTAL CARBON
- 4.4 IC — INORGANIC CARBON

5.0 PROCEDURE

To perform a Multi-Point calibration

- 5.1 If Password protection is enabled, log in to the Analyzer with the appropriate password.
- 5.2 Stop (*Home* screen) or cancel (*Protocols* screen) any current analysis.
- 5.3 Back up the database and settings for later reference.
 - 5.3.1 Insert a USB memory drive into one of the USB host ports and press the *Advanced* tab on the *Maintenance* screen.
 - 5.3.2 Press **BACKUP DATABASE**. The Analyzer begins the backup process.
 - 5.3.3 When the backup is complete, a message appears that it is safe to remove the USB memory drive. Leave the USB memory drive inserted and press **CLOSE**.
 - 5.3.4 Press the *Settings* tab on the *Maintenance* screen.
 - 5.3.5 Press **BACKUP SETTINGS**. Select which settings to back up, including *System* or *Dual Conductivity*.
 - 5.3.6 Press **CONTINUE** and the Analyzer begins the backup process. When the message indicates 100% completion, remove the USB memory drive and press **CLOSE**.

Chapter 6 CALIBRATION

5.4 On the *Protocols*  screen, select the *System Protocols* tab.

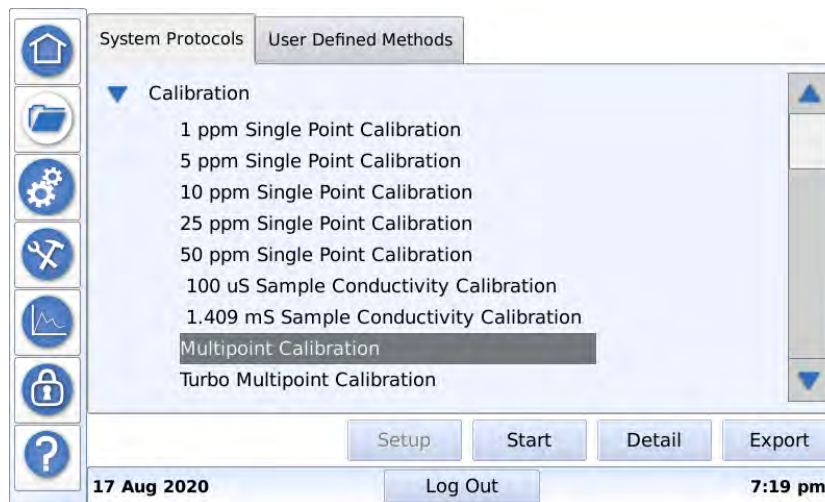

5.5 If regularly analyzing online samples with <50 ppb TOC, perform a TOC Autozero.

5.6 Select **MULTIPOINT CALIBRATION** and press **START**. The *FSE Certification License* dialog box appears.

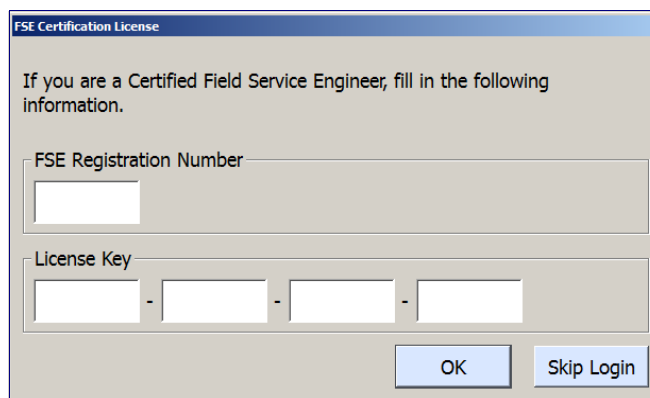
The dialog box is titled 'FSE Certification License'. It contains the text: 'If you are a Certified Field Service Engineer, fill in the following information.' Below this text are two input fields. The first is labeled 'FSE Registration Number' and is a single-line text box. The second is labeled 'License Key' and is a four-part text box with hyphens between the parts. At the bottom right of the dialog box are two buttons: 'OK' and 'Skip Login'.

5.7 If you are a Certified Field Service Engineer, complete the fields and press **OK**. Otherwise, press **SKIP LOGIN**.

5.8 If the Analyzer has not been used during the last eight hours for a protocol that uses oxidizer (such as this one) and a reagent flush has not been

performed, the *8 Hour Reagent Flush* message appears. Otherwise, go directly to step [5.10](#).

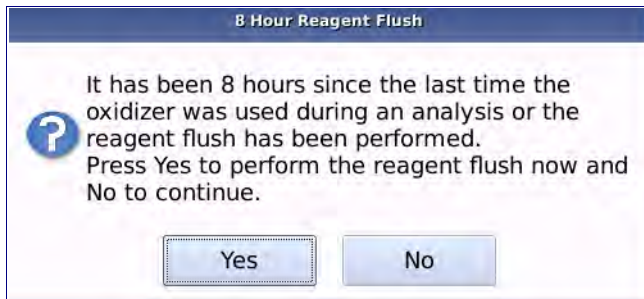

5.9 On the message dialog box, do one of the following:

- *To perform the suggested reagent flush* — Press **YES** to continue and display the *Connect Water Source* dialog box. Insert a 40 mL vial of low-TOC DI water into the iOS System (*On-Line or Portable Analyzer*) or Vial Port (*Laboratory Analyzer*) and press **OK**. The *Syringe Flush* dialog box appears while the Analyzer performs the flush. When the flush is complete, go to step [5.10](#).
- *To continue without performing a reagent flush* - Press **NO** and go to step [5.10](#).

5.10 The *System Protocol: Multipoint Calibration* dialog box appears. Insert the *Blank (Rw)* vial into the iOS or vial port and press **CONTINUE**. The sample analysis begins.

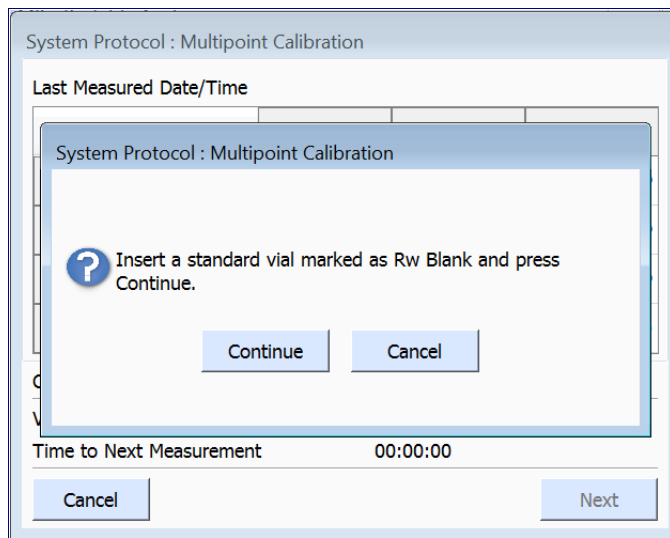

5.11 When the Analyzer completes the measurement, the **NEXT** button will flash.

5.12 Press **NEXT** and follow the Analyzer’s instructions for the remaining vials.

Chapter 6 CALIBRATION

5.13 When the Analyzer completes the measurements, the *Calibration Result* dialog box appears with the results data and indication if the *Calibration Passed* or *Calibration Failed*.

	Rw Blank	250 ppb TOC	1 ppm TOC	
1	2.08ppb	244ppb	980ppb	
2	3.87ppb	243ppb	979ppb	
3	3.22ppb	244ppb	979ppb	
Average	27.7ppb	277ppb	1.04ppm	
RSD	2.09	1.10	0.00	
Expected	N/A	275ppb	1.03ppm	
% Diff	N/A	0.73	0.97	
Adjusted	25.2ppb	271ppb	1.02ppm	

R² = 1.000

Print Export Apply Cancel

5.14 Do one of the following:

- If the calibration passed, press **APPLY** to accept the calibration.
- If the calibration failed, leave the screen as is and contact Technical Support or your local service provider. Before calling, e-mail the backup and system settings files (created in advance of running calibration protocols). After analysis of the data, you may be advised to accept the results or to pursue additional troubleshooting steps.

5.15 To print or export the results, press the corresponding button.

5.16 Remove the last vial from the Analyzer.

Performing a Single-Point Verification for Grab/On-Line Operation

1.0 INTRODUCTION

Use this verification procedure to confirm that the Analyzer's current calibration is within specification. This verification procedure applies to either the Single-Point Calibration or the Multi-Point Calibration. SUEZ also recommends performing this verification after replacement of the (sample) pump heads or reagents.

Verification occurs at a single selectable concentration. Choose a concentration that is appropriate for your application.

2.0 SCOPE

This procedure applies to all Sievers M5310 C Analyzers operating in *Grab* or *On-Line* mode.

3.0 MATERIALS



NOTE: Use *only* Sievers standards purchased from SUEZ.

- 3.1 Sievers M5310 C Analyzer
- 3.2 *Single-Point Verification for Grab/On-Line Worksheet*
- 3.3 Single-Point Verification Standards Set
 - 3.3.1 One vial — Blank (Rw)
 - 3.3.2 One vial — 500 ppb or 1, 2, 5, 10, 25, or 50 ppm TOC (as sucrose)
 - 3.3.3 One vial — 500 ppb or 1, 2, 5, 10, 25, or 50 ppm IC (as Na₂CO₃)
 - 3.3.4 (Optional, if performing a reagent/syringe flush) One vial — DI water.

4.0 DEFINITIONS

- 4.1 DI — DEIONIZED
- 4.2 TOC — TOTAL ORGANIC CARBON
- 4.3 TC — TOTAL CARBON
- 4.4 IC — INORGANIC CARBON

5.0 PROCEDURE

To perform a Single-Point verification

- 5.1 If Password protection is enabled, log in to the Analyzer with the appropriate password.
- 5.2 On the *Protocols*  screen, select the *System Protocols* tab.

Chapter 6 CALIBRATION

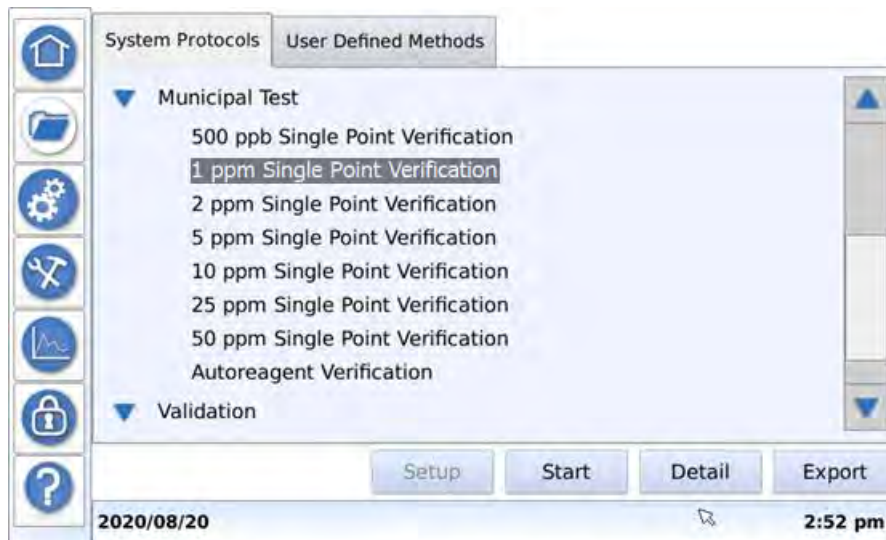

- 5.3 Select the Single Point Verification (500 ppb, 1 ppm, 2 ppm, 5 ppm, 10 ppm, 25 ppm, 50 ppm) to run. Press **START**. If selecting the 500 ppb Single Point Verification, go to step [5.6](#).
- 5.4 If the Analyzer has not been used during the last eight hours for a protocol that uses oxidizer (such as this one) and a reagent flush has not been performed, the *8 Hour Reagent Flush* message appears. Otherwise, go directly to step [5.6](#).

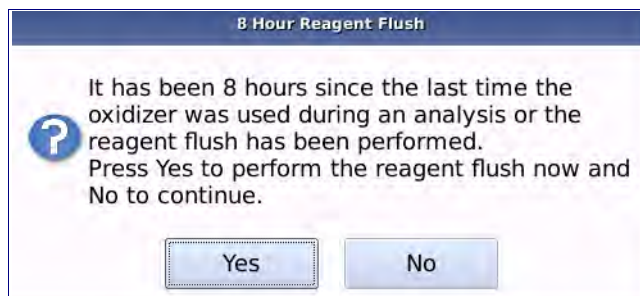

- 5.5 On the message dialog box, do one of the following:
- *To perform the suggested reagent flush* — Press **YES** to continue and display the *Connect Water Source* dialog box. Insert a 40 mL vial of low-TOC DI water into the iOS System (*On-Line or Portable Analyzer*) or Vial Port (*Laboratory Analyzer*) and press **OK**. The Syringe Flush dialog box appears while the Analyzer performs the flush. When the flush is complete, go to step [5.6](#).
 - *To continue without performing a reagent flush* - Press **NO** and go to step [5.6](#).

- 5.6 The *System Protocol: Single Point Verification* dialog box appears. Insert the *Blank (Rw)* vial into the iOS or vial port and press **CONTINUE**. The sample analysis begins.

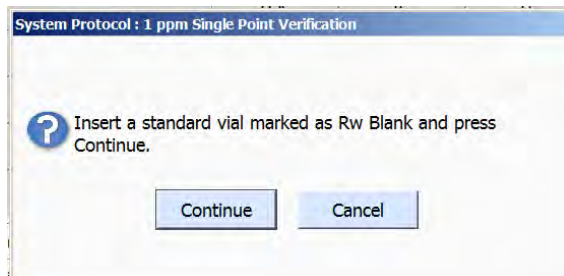

- 5.7 When the Analyzer completes the measurement, the **NEXT** button will flash.
- 5.8 Press **NEXT** and follow the Analyzer's instructions for the remaining vials.
- 5.9 When the Analyzer completes the measurements, the *Single Point Verification Result* dialog box appears with the result data and indication if the Verification *Passed* or *Failed*.

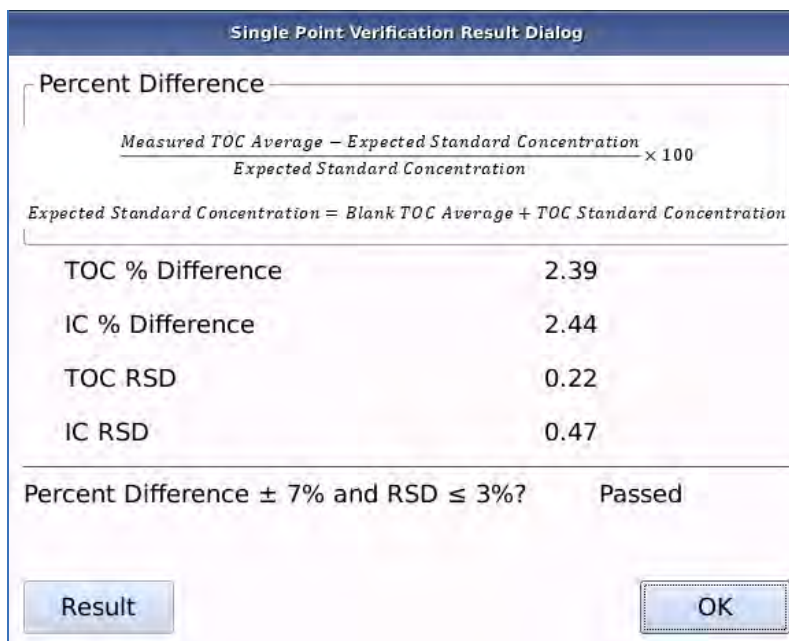

- 5.10 Press **RESULT**. The *Verification Summary* screen appears.
- 5.11 To print or export the results, press the corresponding button.
- 5.12 Press **OK** to return to the *Single Point Verification Result* dialog box.
- 5.13 Press **OK** to return to the *System Protocols* tab.
- 5.14 Remove the last vial from the Analyzer.

Performing an Autoreagent Verification for Grab/On-Line Operation (Optional)

1.0 INTRODUCTION

If using the Autoreagent function, use the Autoreagent Verification to confirm the Analyzer's Autoreagent function is within specification. SUEZ recommends performing the Autoreagent verification during routine maintenance or after calibration. SUEZ also recommends performing a Multi-Point Calibration or a Single-Point Verification prior to performing the Autoreagent Verification.

2.0 SCOPE

This procedure applies to all Sievers M5310 C Analyzers operating in *Grab* or *On-Line* mode.

3.0 MATERIALS



NOTE: Use *only* Sievers standards purchased from SUEZ.

- 3.1 Sievers M5310 C Analyzer
- 3.2 *Autoreagent Verification for Grab/On-Line Worksheet*
- 3.3 Reagents Verification Standards Set
 - 3.3.1 One vial — 10 ppm TOC (as KHP)
 - 3.3.2 One vial — 25 ppm TOC (as KHP)
- 3.4 (Optional, if performing a reagent/syringe flush) One vial — DI water.

4.0 DEFINITIONS

- 4.1 DI — DEIONIZED
- 4.2 TOC — TOTAL ORGANIC CARBON
- 4.3 TC — TOTAL CARBON
- 4.4 IC — INORGANIC CARBON

5.0 PROCEDURE

To perform an Autoreagent Verification

- 5.1 If Password protection is enabled, log in to the Analyzer with the appropriate password.
- 5.2 Stop (*Home* screen) or cancel (*Protocols* screen) any current analysis.
- 5.3 On the *Protocols*  screen, select the *System Protocols* tab.

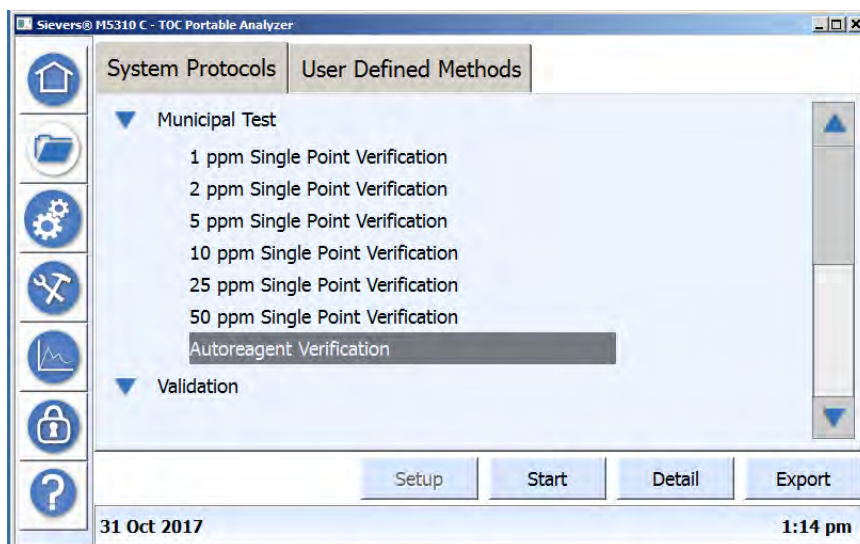

- 5.4 Select **AUTOREAGENT VERIFICATION** and press **START**.
- 5.5 If the Analyzer has not been used during the last eight hours for a protocol that uses oxidizer (such as this one) and a reagent flush has not been performed, the *8 Hour Reagent Flush* message appears. Otherwise, go directly to step [5.7](#).

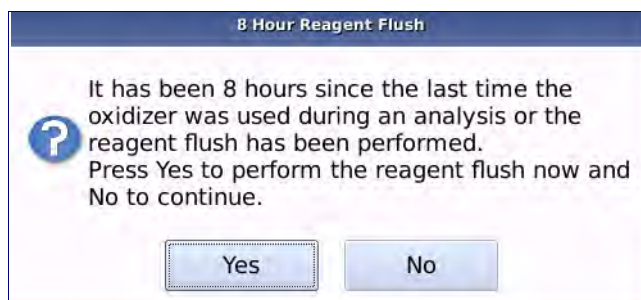

- 5.6 On the message dialog box, do one of the following:
 - *To perform the suggested reagent flush* — Press **YES** to continue and display the *Connect Water Source* dialog box. Insert a 40 mL vial of low-TOC DI water into the iOS System (*On-Line or Portable Analyzer*) or Vial Port (*Laboratory Analyzer*) and press **OK**. The Syringe Flush dialog box

Chapter 6 CALIBRATION

appears while the Analyzer performs the flush. When the flush is complete, go to step [5.7](#).

- *To continue without performing a reagent flush* - Press **NO** and go to step [5.7](#).

5.7 The *System Protocol: Autoreagent Verification* dialog box appears. Insert the *10 ppm TOC* vial into the iOS or vial port and press **CONTINUE**. The autoreagent verification begins.

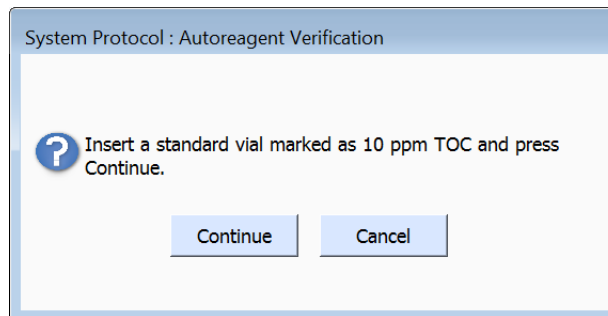

5.8 When the Analyzer completes the measurement, the **NEXT** button will flash.

5.9 Press **NEXT** and follow the Analyzer's instructions for the remaining vials.

5.10 When the Analyzer completes the measurements, the *Autoreagent Verification Result* dialog box appears with an indication if the Autoreagent Verification *passed* or *failed*.

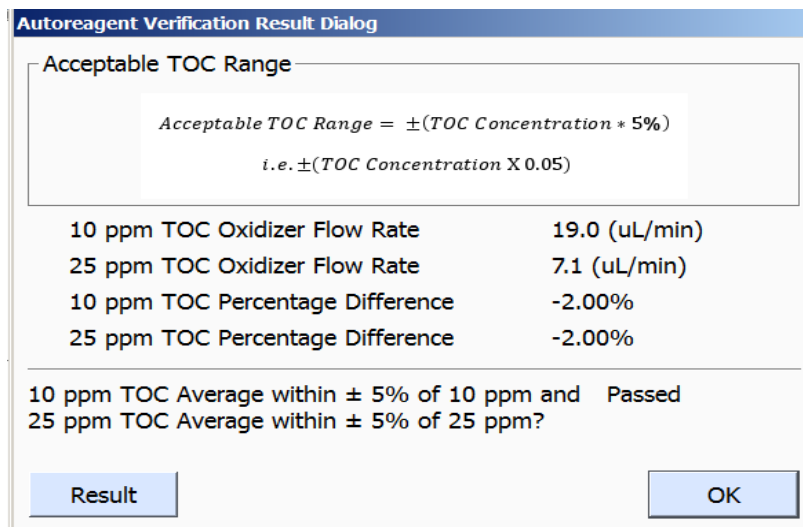

5.11 Press **RESULT**. Details of the result appear on the *Autoreagent Verification* dialog box.

System Protocol : Autoreagent Verification			
10 ppm TOC	TOC	IC	TC
2	9.80ppm	300ppb	10.1ppm
3	9.80ppm	301ppb	10.1ppm
4	9.80ppm	301ppb	10.1ppm
Average	9.80ppm	301ppb	10.1ppm
SD	0.24ppb	0.44ppb	0.31ppb
RSD	0.00	0.15	0.00
25 ppm TOC	TOC	IC	TC
2	24.5ppm	751ppb	25.3ppm
3	24.5ppm	751ppb	25.3ppm
4	24.5ppm	750ppb	25.3ppm

Buttons: Print, Export, OK

5.12 To print or export the results, press the corresponding button.

5.13 Press **OK** to return the previous *Autoreagent Verification Result* dialog box.

5.14 Press **OK** to return to the *Protocols* tab.

5.15 Remove the last vial from the Analyzer.

CALIBRATION HISTORY

The summary of results data for past calibration and verification protocols is located on the *Data View*  screen. View various levels of detail and export data, as needed.

Viewing Calibration History

To view and export calibration/verification history

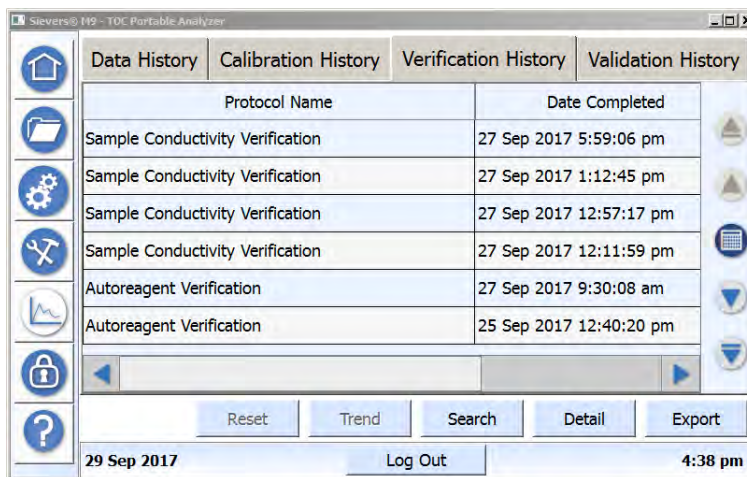



Figure 41: The Data View Screen

1. On the *Data View*  screen, press one of the following:
 - *Calibration History* tab — Contains results from past *TOC Autozero*, *Single-Point Calibration*, *Multi-Point Calibration*, *Single-Point Verification* protocol analyses.
 - *Municipal Test History* tab — Contains results from past *Single-Point Verification*, *Accuracy / Precision*, and *Autoreagent Verification* protocol analyses.
 - *Validation History* tab — Contains results from past *ICR Validations*.
2. Use the horizontal scroll bar and the *up* and *down* arrows to scroll through the list, as needed. To search by date, press the calendar  icon. Or, to search for a specific protocol, press **SEARCH**, enter search criteria, and press **SEARCH**.
3. Select a line and press **DETAIL** to view additional information. Details of the results appear. Press **PRINT** to print the details appearing on this dialog box.
4. Press one the following to view additional results and protocol data:
 - *Summary* (protocol definition)
 - *Results* (for each repetition and statistics)
 - *Protocol* (data)
5. When finished viewing the data, press **OK** to return to the tab view.
6. To export the data, insert a USB memory drive into one of the USB host ports. Select the protocol line and press **EXPORT**.

7

MAINTENANCE

OVERVIEW

To ensure optimal performance of the Analyzer, perform the routine preventative maintenance tasks described in this chapter and follow the recommended maintenance schedule ([Figure 182: Consumables Replacement Schedule on page 182](#)) for the replacement of Analyzer consumables. SUEZ recommends using the chemical reagents, the in-line filter, UV lamp, resin cartridge, and sample pump heads designed for use with the M-Series Analyzers and available from SUEZ.



NOTE: *The use of consumables from other sources—or the failure to replace the consumables on the prescribed replacement schedule—will void the Analyzer’s warranty.*

This chapter applies to ALL Sievers M5310 C TOC Analyzer instrument models, except where noted. An interior overview diagram of each Analyzer model is provided for reference. (See [“Interior Views of the Analyzer” on page 176.](#))

If you need additional assistance when performing this preventative maintenance, contact Technical Support or your local service provider.

Installation and training by a qualified service technician are also available.

Chapter 7 MAINTENANCE

INTERIOR VIEWS OF THE ANALYZER

Locate the diagram in this section for your Analyzer (*On-Line, Laboratory, or Portable*) and refer to it as needed when performing the preventative maintenance described in this chapter.



NOTE: The following diagrams are provided to assist in identifying Analyzer components and consumables only. Cable and tubing positions and connections may be removed or repositioned to show other components.

On-Line Analyzer Views



Figure 42: Interior Overview — Sievers M5310 C On-Line TOC Analyzer



Figure 43: Electronics Enclosure (Top Shelf) — Sievers M5310 C On-Line TOC Analyzer

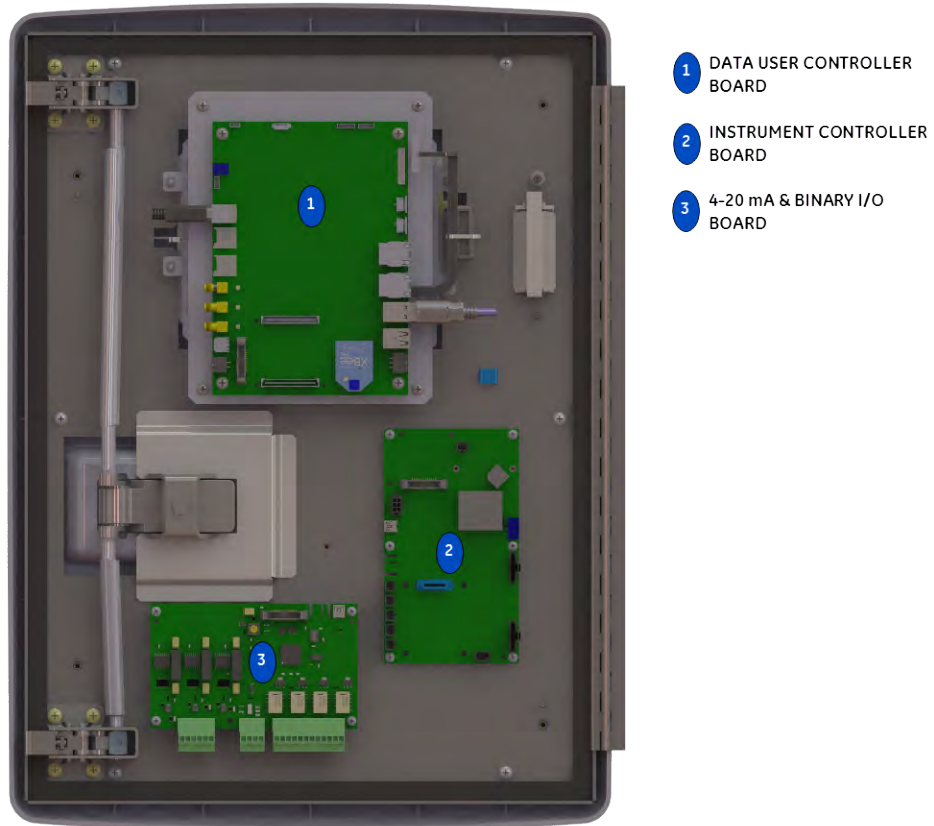

Figure 44: Electronics on Inside Door — Sievers M5310 C On-Line TOC Analyzer

Chapter 7 MAINTENANCE

Laboratory Analyzer Views

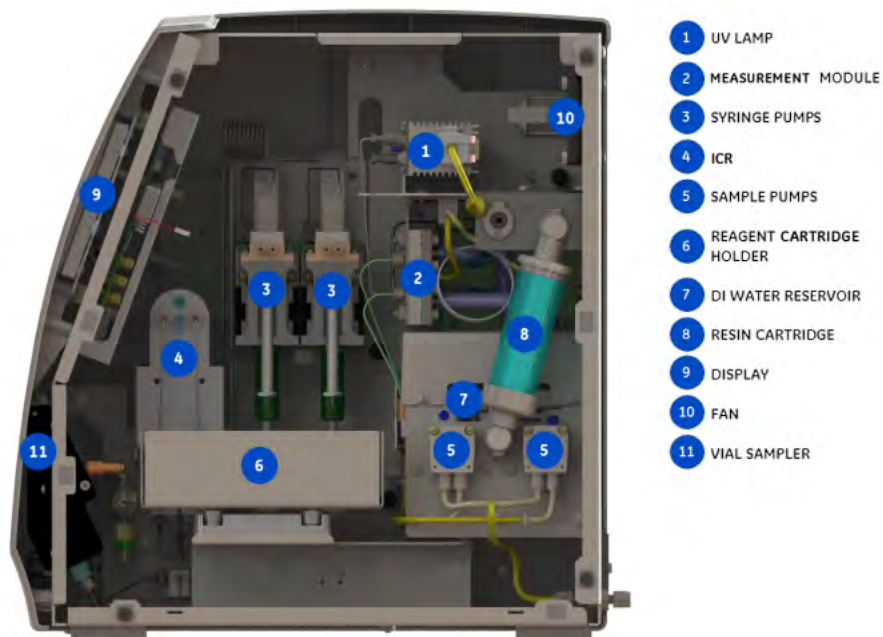

Figure 45: Fluidics Side — Sievers M5310 C Laboratory TOC Analyzer

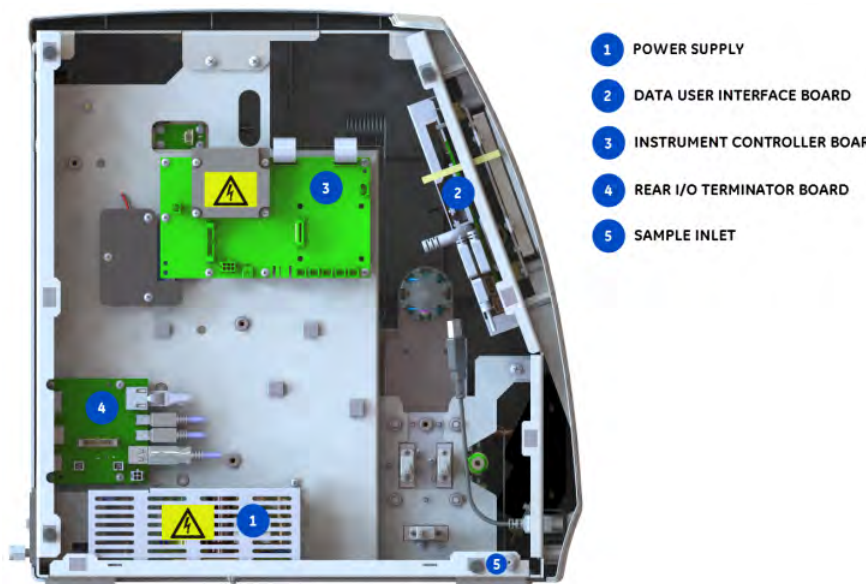

Figure 46: Electronics Side — Sievers M5310 C Laboratory TOC Analyzer

Portable Analyzer Views

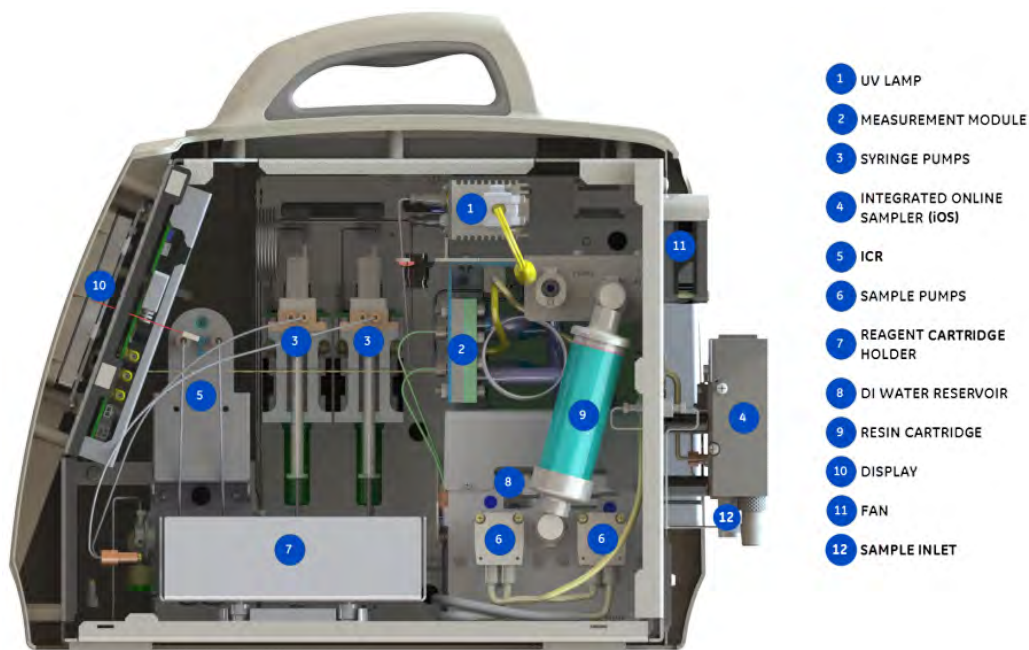

Figure 47: Fluidics Side — Sievers M5310 C Portable TOC Analyzer

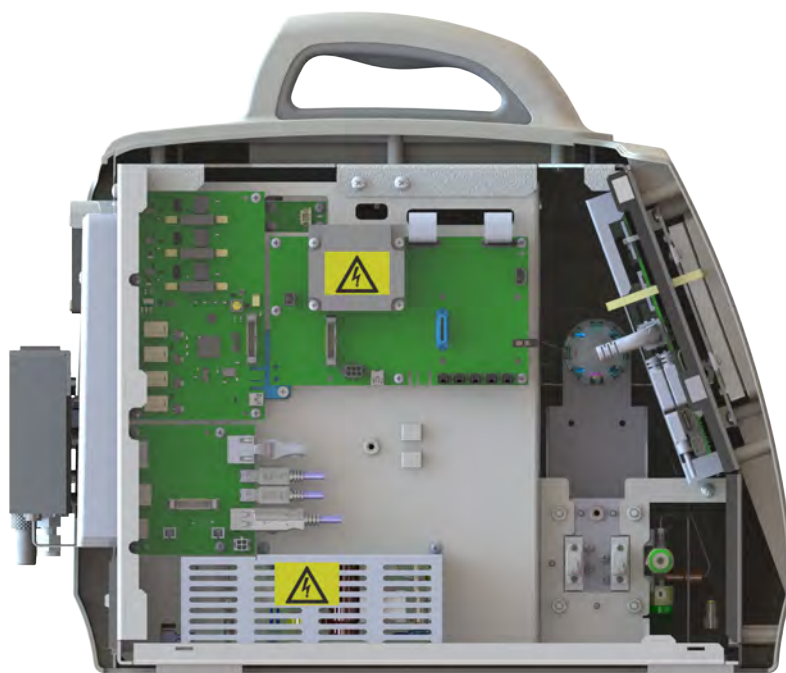

Figure 48: Electronics Side — Sievers M5310 C Portable TOC Analyzer

Chapter 7 MAINTENANCE

MONITORING ANALYZER MAINTENANCE

Consumables monitoring and maintenance tasks are included on the Analyzer's *Home* screen and the *Maintenance* screen.

Monitoring Consumables Using the Home Screen

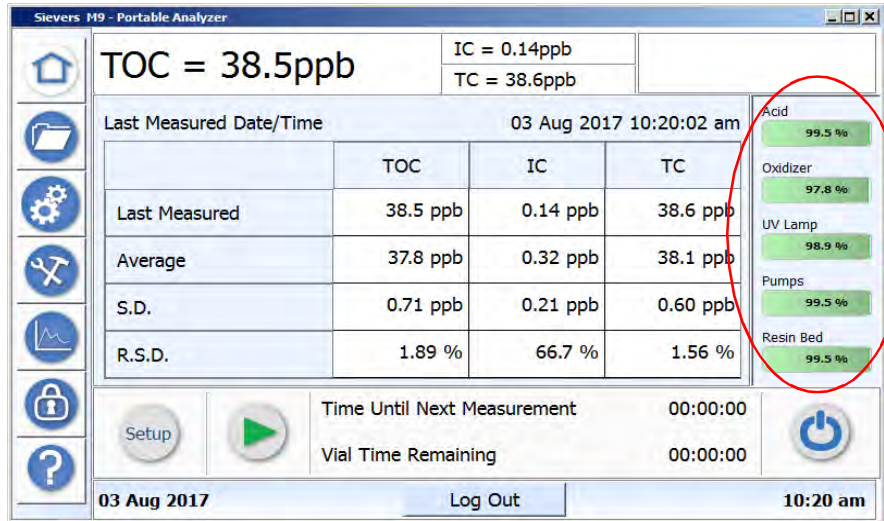



Figure 49: The Home Screen with Consumables Levels

Monitor the remaining general consumables levels on the Analyzer's *Home* screen, using the status indicators (showing percent remaining) located on the right portion of the screen, for the following:

- Acid
- Oxidizer
- UV Lamp
- Pumps (sample pump heads)
- Resin Cartridge

A warning message appears on the Analyzer screen to indicate expiring consumables, and an error message (preventing analysis) appears if the consumable is not replaced by the expiration date. For additional information on specific warning and error messages, please refer to [Chapter 8. "Troubleshooting."](#)



NOTE: You can disable the display **and** all other outputs of warnings for consumables. For more information, see ["To set preferences for warnings" on page 122](#). All warnings are still displayed on the Error History tab located on the Maintenance screen. 

Monitoring Consumables Using the Maintenance Screen

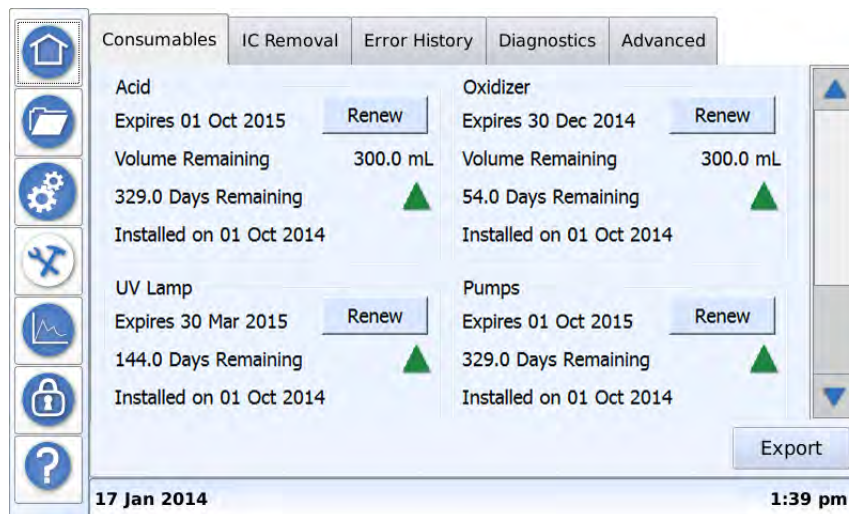

Figure 50: The Maintenance Screen with Consumables Tab

Use the *Maintenance* screen for the following:

- Renewing and tracking consumables expiration — *Consumables* Tab
- Renewing and tracking ICR consumables expiration — *IC Removal* Tab
- Flushing reagent syringes — *Advanced* Tab
- Temporarily disabling the screen for cleaning — *Advanced* Tab



NOTE: For more information about using the Maintenance screen for other functions, see [“The Maintenance Screen” on page 131](#).

TRACKING AND RENEWING CONSUMABLES EXPIRATION

Proactively replace the following Analyzer consumables according to [Table 12: “Consumables Replacement Schedule” on page 182](#). Use the *Maintenance* screen to track current volumes remaining for the acid and oxidizer reagents, as well as the installation and number of days remaining. For other general and ICR consumables, the Analyzer reports the installation date and number of days remaining.

Also use the *Maintenance* screen to renew consumables expiration dates after replacing the item during routine maintenance tasks.

Chapter 7 MAINTENANCE

Consumables Replacement Schedule

TABLE 12: CONSUMABLES REPLACEMENT SCHEDULE

Description	Typical Operating Life
General Consumables	
DI water reservoir	Refill as needed (<i>Check when replacing reagents or UV lamp.</i>)
Oxidizer	3 calendar months, maximum
Acid	12 calendar months, maximum
UV lamp	6 months
Sample pump heads	12 months
Resin cartridge	12 months
Inline filter (<i>On-Line mode</i>)	Replace as needed
ICR Consumables	
ICR degasser (<i>ICR configurations</i>)	24 months

Annual Maintenance and Calibration Activities

Replacement of consumables may affect TOC.

We recommend performing calibration and calibration verification activities **annually** — **after** performing annual maintenance tasks, including replacing the UV lamp, sample pump heads, and resin cartridge.

- **3-month service:** Replace oxidizer. Replace acid, if needed.
- **6-month service:**
 - Replace oxidizer. Replace acid, if needed.
 - Replace UV lamp.
 - Verify TOC calibration. Use the concentration defined in Standard Operating Procedures as the verification level. Calibrate if needed.
- **Annual (12-month) service:**
 - Replace oxidizer and acid.
 - Replace UV lamp, sample pump heads, and resin cartridge.
 - Perform annual TOC calibration activities.

For ICR maintenance activities, we recommend performing ICR verification after successfully performing ICR maintenance, including replacing the ICR degasser, ICR



diaphragm, or ICR chemical trap. For more information about ICR consumables replacement dates, see [“Tracking Consumables Levels” on page 185](#).

For unscheduled replacement of the UV lamp, pump heads, or resin cartridge, we recommend verification of the TOC calibration. Calibrate if needed.

[Table 13 on page 184](#) shows recommended calibration and calibration verification activities after replacement of each consumable.

For major repair of the measurement module, we recommend TOC calibration followed by verification at the selected concentration points. [Table 14 on page 184](#) shows recommended calibration and calibration verification activities after major repairs.

Chapter 7 MAINTENANCE

TABLE 13: VERIFICATION / CALIBRATION ACTIVITIES AFTER CONSUMABLES REPLACEMENT

Consumable	Typical Operating Life	TOC Verification / Calibration
Oxidizer	3 months	None needed
Acid	3-12 months	None needed
UV lamp	6 months	<p>6-month service: We recommend verification. Calibrate if needed.</p> <p>Annual (12-month) service: Replace <i>before</i> performing annual calibration activities.</p> <p>Unscheduled replacement: We recommend verification. Calibrate if needed.</p>
Pump heads	12 months	<p>Annual (12-month) service: Replace <i>before</i> performing annual calibration activities.</p> <p>Unscheduled replacement: We recommend verification. Calibrate if needed.</p>
Resin cartridge	12 months	<p>Annual (12-month) service: Replace <i>before</i> performing annual calibration activities.</p> <p>Unscheduled replacement: We recommend verification. Calibrate if needed.</p>

TABLE 14: VERIFICATION / CALIBRATION ACTIVITIES AFTER MAJOR REPAIR

Repair	TOC Verification / Calibration
Measurement Module	We recommend calibration followed by verification at the selected concentration point(s).

Tracking Consumables Levels

The Analyzer tracks remaining volume by calendar days and by extracted volume. The Analyzer issues an approximate 15-day warning before the expiration date or before the volume reaches 0%.



NOTE: You can disable the display **and** all other outputs of warnings for consumables. For more information, see [“To set preferences for warnings” on page 122](#). All warnings are still displayed on the Error History tab located on the Maintenance  screen.

Use the *Consumables* tab on the *Maintenance* screen to view general consumables volumes and expiration dates:

- Acid
- Oxidizer
- UV Lamp
- Pumps (sample pump heads)
- Resin Cartridge

Use the *IC Removal* (ICR) tab to view expiration information for the following ICR component consumables:

- ICR degasser

A triangle icon appears next to the **RENEW** button to indicate the severity of the expiration date by the color of the triangle. A green triangle indicates an adequate time frame for the consumable's life remains, yellow indicates less 10% remains, and red indicates that less than 5% remains.

Renewing Expiration Dates

After installing a new UV lamp, sample pump heads, or a resin cartridge in the Analyzer (as described later in [“Replacing Reagents and Other Consumables” on page 186](#)), use the *Consumables* tab and *IC Removal* (ICR) tab to renew the consumable so that the Analyzer can track the usage and issue reminders for its expiration.

To renew an expiration date

1. On the *Maintenance*  screen, select one of the following:
 - *Consumables* tab — Renew general consumables, including: reagents, UV lamp, sample pump heads, and resin cartridge.
 - *IC Removal* (ICR) tab — Renew the ICR degasser.

Chapter 7 MAINTENANCE

2. Press the **RENEW** button next to the consumable item that has been replaced. The *Renew Consumable* dialog box appears with installation, expiration, and volume information based on the type of consumable.

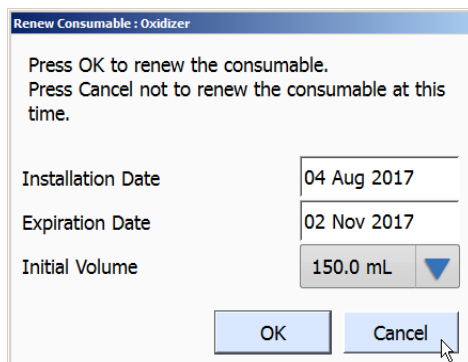

Renew Consumable : Oxidizer

Press OK to renew the consumable.
Press Cancel not to renew the consumable at this time.

Installation Date 04 Aug 2017

Expiration Date 02 Nov 2017

Initial Volume 150.0 mL ▼

OK Cancel

3. In the *Installation Date* field, leave the default date (today's date) or type a new date. The new date value can be any date up to one year from today's date.
4. In the *Expiration Date* field, leave the default date (one year from today) or type a new date. The new date value can be any date up to one year from today's date.
5. Select *150.0 mL* or *300.0 mL* from the *Initial Volume* list for the cartridge you are installing.
6. Press **OK**. The information is now updated in the Analyzer and on the *Consumables* tab.

REPLACING REAGENTS AND OTHER CONSUMABLES

This section includes detailed instructions for replacing reagents and other consumables according to the frequency listed in the [“Consumables Replacement Schedule” on page 182](#). Step-by-step instructions for each of the following consumables categories are included:

- [“Replacing the Chemical Reagents” on page 186](#)
- [“Replacing other Consumables” on page 195](#)
- [“Replacing ICR Consumables” on page 208](#)

Replacing the Chemical Reagents

There are two types of reagent cartridges. The CLEAR CARTRIDGE type includes a red/green button valve on the inlet nozzle. The other OPAQUE CARTRIDGE type does not have a valve, but has a plug with containment tape over the inlet nozzle. The OPAQUE CARTRIDGE type also has a vent on the bottom of the cartridge, covered by a

yellow sticker with a red tab. The two types are shown in [Figure 188: Identifying Reagent Cartridge Types on page 188](#).





The installation steps for replacing chemical reagents differs depending upon the Analyzer and the type of reagent cartridge:



- [“To replace a reagent cartridge \(Opaque type\) — Lab and Portable Analyzers” on page 188](#)
- [“To replace a reagent cartridge \(Clear type\) — Lab and Portable Analyzers” on page 190](#)
- [“To replace a reagent cartridge \(Opaque type\) — On-Line TOC Analyzer” on page 192](#)
- [“To replace a reagent cartridge \(Clear type\) — On-Line TOC Analyzer” on page 193](#)

Before installing new chemical reagents, ensure the following:

- Analysis is stopped.
- The operating system is shut down, the Analyzer power switch is Off, and the power cord is disconnected (*Laboratory and Portable TOC Analyzers*) or Mains is off (*On-Line TOC Analyzer*).

Review the following safety warnings and identify the type of reagent cartridge you have by reviewing [“Identifying Reagent Cartridge Types” on page 188](#).

Know These Safety Warnings	
	Hazardous reagents (ammonium persulfate and phosphoric acid) are used in the Analyzer. Before installing a reagent, read the corresponding Material Safety Data Sheet (MSDS) for proper handling precautions and spill or leak procedures. The MSDS are contained in the pouch located on the outside of the reagent shipping box.
	Installation of reagents and most Analyzer maintenance requires access to the inside of the Analyzer. To avoid potentially dangerous shock—BEFORE opening the Analyzer—first stop any analysis, stop the operating system (using the Shut Down  button in the Analyzer’s firmware), then turn off power and disconnect from the power supply.
	To avoid exposure to the chemical reagents, wear acid-resistant gloves and safety goggles.

Know These Safety Warnings	
	<p>Reagent cartridges are for single-use only. Do not refill. Any refilling or reusing of reagent cartridges will void all Analyzer and parts warranties and nullify any performance claims.</p>
	<p>Keep the OPAQUE type reagent cartridge in an upright position before attaching and detaching the reagent supply line to avoid exposure to the chemical reagent. Save the plug to later reinsert it into the nozzle inlet after removing the cartridge from the Analyzer during a cartridge replacement process.</p>



***Opaque Reagent Cartridge Type
(without Red/Green Button Valve)***

***Clear Reagent Cartridge Type
(with Red/Green Button Valve)***

Figure 51: Identifying Reagent Cartridge Types

To replace a reagent cartridge (Opaque type) — Lab and Portable Analyzers

This procedure includes instructions for replacing the **OPAQUE TYPE** reagent cartridges *Acid*, *Oxidizer*, or both in a *Sievers Laboratory or Portable TOC Analyzer*. (Refer to [Figure 51: Identifying Reagent Cartridge Types](#) on page 188 to identify. The **OPAQUE TYPE** cartridge does **not** have a red and green valve button valve.)

1. Before opening and working inside the Analyzer (and working with the chemical reagents) ensure that:
 - The Analyzer power switch is Off and the power cord is disconnected. (ALWAYS stop the operating system first by using the **SHUT DOWN** button on the *Home* screen **before** turning the power switch to **OFF**.)
 - You are wearing the recommended personal protective equipment (PPE), as outlined in the previous Safety Warnings.
2. Open the Analyzer by removing the right side panel. (The panel is attached to the Analyzer by magnets.) Stabilize the instrument with one hand on the top panel (*Laboratory TOC Analyzer*) or handle (*Portable TOC Analyzer*). Grasp the edge of the right side panel from the back of the Analyzer. Pull the entire panel away from the instrument.
3. Locate and remove the reagent holder. Set it next to the Analyzer for the disassembly and assembly processes. Stand the holder up vertically on its short side with the cut-out end pointed upward and the label facing you.
4. Start with the *Acid* reagent cartridge. Leaving the reagent supply line connected, remove the installed cartridge from the holder. Next, disconnect the reagent supply line by detaching the PEEK nut from the inlet at the top of the *Acid* reagent cartridge. (The reagent supply line for the *Acid* reagent cartridge is labeled *Acid*. The reagent supply line for the *Oxidizer* reagent cartridge is labeled *Oxidizer*.)

Insert the PEEK nut plug (saved from the last time the reagent cartridge was replaced) into the inlet nozzle of the cartridge.
5. Repeat the previous step for the *Oxidizer* reagent cartridge.
6. Set aside the cartridges to dispose of according to federal, state, and local government regulations.
7. If replacing both cartridges, start with the *Acid* reagent cartridge. Pull the red tab to remove the yellow sticker from the vent on the bottom of the cartridge. Pause briefly to let the air vent.
8. Holding the cartridge with the plugged nozzle inlet facing upward (as directed by the “This end up” label), remove the containment tape from the top of the cartridge inlet nozzle. Next, remove the plug from the nozzle. (SAVE the plug to use in a future replacement process.)
9. Inside the Analyzer, locate the reagent supply line with the label that matches the cartridge being replaced. (The reagent supply line for the *Acid* cartridge is labeled *Acid*. The reagent supply line for the *Oxidizer* cartridge is labeled *Oxidizer*.) Attach the reagent supply-line PEEK nut to the inlet at the top of the reagent cartridge and tighten finger tight.
10. Repeat steps [8](#) and [9](#) to connect the *Oxidizer* reagent cartridge.

Chapter 7 MAINTENANCE

11. If replacing the *Acid* reagent cartridge, place the cartridge in the back compartment of the reagent holder, ensuring that the nozzle-end of the cartridge is pointed upward through the cutout portion of the reagent holder and is closest to the bottom.
12. If replacing the *Oxidizer* reagent cartridge, place the cartridge in the front compartment of the reagent holder, ensuring that the nozzle-end of the reagent cartridge is pointed upward through the cutout portion of the reagent holder and is closest to the bottom.
13. Lift the entire reagent holder (with the *Acid* and *Oxidizer* reagent cartridges in place) and set the holder horizontally onto the reagent holder mount, which is located on the floor of the unit. The magnet feet of the holder fit into the corner grooves on the mount. You should feel the magnets secure the holder into place.
14. Replace the side panel on the Analyzer. Ensure that the magnets have connected and the panel is secure.
15. After replacing an *Acid* and/or *Oxidizer* reagent cartridge, record the installation on the *Consumables* tab of the *Maintenance* screen. In the appropriate *Acid* or *Oxidizer* section, press **RENEW**. For more information refer to [“To renew an expiration date” on page 185](#).

To replace a reagent cartridge (*Clear type*) — *Lab and Portable Analyzers*

This procedure includes instructions for replacing either an *Acid* or *Oxidizer* cartridge of the **CLEAR CARTRIDGE** type in a *Sievers Laboratory or Portable TOC Analyzer*. (Refer to [“Identifying Reagent Cartridge Types” on page 188](#) to identify. The **CLEAR TYPE** cartridge type HAS a red and green valve button valve.)

1. Before opening and working inside the Analyzer (and working with the chemical reagents) ensure that:
 - The Analyzer power switch is Off and the power cord is disconnected. (ALWAYS stop the operating system first by using the **SHUT DOWN** button on the *Home* screen BEFORE turning the power switch to **OFF**.)
 - You are wearing the recommended personal protective equipment (PPE), as outlined in the previous Safety Warnings.
2. Open the Analyzer by removing the right side panel. (The panel is attached to the Analyzer by magnets.) Stabilize the instrument with one hand on the top panel (*Laboratory TOC Analyzer*) or handle (*Portable TOC Analyzer*). Grasp the edge of the right side panel from the back of the Analyzer. Pull the entire panel away from the instrument.

3. Locate and remove the reagent holder, setting it next to the Analyzer for the disassembly and assembly processes. Stand the holder up vertically on its short side with the cut-out end pointed upward and the label facing you.
4. Slide the red button on the nozzle inlet of the cartridge in to close the valve.
5. Start with the *Acid* reagent cartridge. Remove the installed cartridge from the holder. Disconnect the reagent supply line by detaching the PEEK nut from the inlet at the top of the reagent cartridge. (The reagent supply line for the *Acid* reagent cartridge is labeled *Acid*. The reagent supply line for the *Oxidizer* reagent cartridge is labeled *Oxidizer*.)

Insert the PEEK nut plug (saved from the last time the reagent cartridge was replaced) into the inlet nozzle of the cartridge.

6. Repeat steps [4](#) and [5](#) for the *Oxidizer* cartridge.
7. Set aside the cartridges to dispose of according to federal, state, and local government regulations.
8. Start with the *Acid* reagent cartridge. Inside the Analyzer, locate the reagent supply line with the label that matches the cartridge being installed. (The reagent supply line for the *Acid* reagent cartridge is labeled *Acid*. The reagent supply line for the *Oxidizer* reagent cartridge is labeled *Oxidizer*.) Attach the supply-line PEEK nut to the inlet at the top of the reagent cartridge and tighten finger tight.
9. Slide the green button on the nozzle inlet in to open the valve.
10. Repeat steps [8](#) and [9](#) for the *Oxidizer* reagent cartridge.
11. If replacing the *Acid* reagent cartridge, place the cartridge in the back compartment of the reagent holder, ensuring that the nozzle-end of the cartridge is pointed upward through the cutout portion of the reagent holder.
12. If replacing the *Oxidizer* reagent cartridge, place the cartridge in the front compartment of the reagent holder, ensuring that the nozzle-end of the cartridge is pointed upward through the cutout portion of the reagent holder.
13. Lift the entire reagent holder (with the *Acid* and *Oxidizer* reagent cartridges in place) and set the holder horizontally onto the reagent holder mount, which is located on the floor of the unit. The magnet feet of the holder fit into the corner grooves on the mount. Ensure the magnets secure the holder into place.
14. Replace the side panel on the Analyzer. Stabilize the instrument with one hand on the top panel (*Laboratory TOC Analyzer*) or handle (*Portable TOC Analyzer*). Use the other hand to fit the panel in place. Ensure that the magnets have connected and the panel is secure.
15. After replacing an *Acid* and/or *Oxidizer* reagent cartridge, record the installation on the *Consumables* tab of the *Maintenance* screen. In the appropriate *Acid* or *Oxidizer* section, press **RENEW**. For more information refer to [“To renew an expiration date” on page 185](#).

To replace a reagent cartridge (*Opaque type*) — *On-Line TOC Analyzer*

This procedure includes instructions for replacing either an *Acid* or *Oxidizer* cartridge of the **OPAQUE CARTRIDGE** type in a *Sievers On-Line TOC Analyzer*. (Refer to [“Identifying Reagent Cartridge Types” on page 188](#) to identify. This **OPAQUE TYPE** cartridge does **not** have a red and green valve button valve.)

1. Before opening and working inside the Analyzer (and working with the chemical reagents) ensure that:
 - The Analyzer power switch is Off and the power cord is disconnected. (ALWAYS stop the operating system first by using the **SHUT DOWN** button on the *Home* screen BEFORE turning the power switch to **OFF**.)
 - You are wearing the recommended personal protective equipment (PPE), as outlined in the previous Safety Warnings.
2. Open the door to the Analyzer. Push the release button and pull the tab to unlatch the door.
3. Loosen the thumbscrews on the reagent housing cover, which is located on the (lower front) floor of the Analyzer. Lift the cover straight up to remove and set it aside during the assembly process.
4. Leaving the reagent supply line connected, remove the installed cartridge from the housing cradle. Next, disconnect the reagent supply line by detaching the PEEK nut from the inlet at the top of the *Acid* reagent cartridge. (The reagent supply line for the *Acid* reagent cartridge is labeled *Acid*. The reagent supply line for the *Oxidizer* reagent cartridge is labeled *Oxidizer*.)

Insert the PEEK nut plug (saved from the installation process) into the inlet nozzle of the cartridge.
5. Repeat the previous step for the *Oxidizer* reagent cartridge.
6. Set aside the cartridges to dispose of according to federal, state, and local government regulations.
7. If replacing both cartridges, start with the *Acid* reagent cartridge. Pull the red tab to remove the yellow sticker from the vent on the bottom of the *Acid* cartridge.
8. Holding the cartridge with the plugged nozzle inlet facing upward (as directed by the “This end up” label), remove the containment tape from the top of the cartridge inlet nozzle. Next, remove the plug from the nozzle. (SAVE the plug to use in a future replacement process.)

9. Inside the Analyzer, locate the reagent supply line with the label that matches the cartridge being replaced. (The reagent supply line for the *Acid* cartridge is labeled *Acid*. The reagent supply line for the *Oxidizer* cartridge is labeled *Oxidizer*.) Attach the supply-line PEEK nut to the inlet at the top of the *Acid* reagent cartridge and tighten finger tight.
10. Repeat steps [8](#) and [9](#) for the *Oxidizer* reagent cartridge.
11. If replacing the *Acid* reagent cartridge, place the *Acid* cartridge into the back compartment of the reagent housing, positioning the cartridge horizontally with the tubing-end facing toward the right and open-side of the housing.
12. If replacing the *Oxidizer* reagent cartridge, place the cartridge into the front compartment of the reagent holder, positioning the cartridge horizontally with the tubing-end facing toward the right and open-side of the housing.
13. Carefully lower the reagent housing cover over the reagents, sliding the guide pin (located toward the back and on top of the reagent housing) through the guide hole on the cover.

Also, make sure that the two tubing lines are carefully positioned between the cover and cradle-side cushions of the housing.
14. Tighten the thumbscrews on the reagent housing cover to secure.
15. Close and latch the door to the Analyzer.
16. After replacing an *Acid* and/or *Oxidizer* reagent cartridge, record the installation on the *Consumables* tab of the *Maintenance* screen. In the appropriate *Acid* or *Oxidizer* section, press **RENEW**. For more information refer to [“To renew an expiration date” on page 185](#).

To replace a reagent cartridge (*Clear type*) — *On-Line TOC Analyzer*

This procedure includes instructions for replacing either an *Acid* or *Oxidizer* cartridge of the **CLEAR CARTRIDGE** type in a *Sievers On-Line TOC Analyzer*. (Refer to [“Identifying Reagent Cartridge Types” on page 188](#) to identify. The **CLEAR TYPE** cartridge HAS a red and green valve button valve.)

1. Before opening and working inside the Analyzer (and working with the chemical reagents) ensure that:
 - The Analyzer power switch is Off and the power cord is disconnected. (ALWAYS stop the operating system first by using the **SHUT DOWN** button on the *Home* screen BEFORE turning the power switch to **OFF**.)
 - You are wearing the recommended personal protective equipment (PPE), as outlined in the previous Safety Warnings.

Chapter 7 MAINTENANCE

2. Open the door to the Analyzer. Push the release button and pull the tab to unlatch the door.
3. Loosen the thumbscrews on the reagent housing cover, which is located on the (lower front) floor of the Analyzer. Lift the cover straight up to remove and set it aside during the assembly process.
4. Slide the red button on the nozzle inlet of the cartridge in to close the valve.
5. Start with the Acid reagent cartridge. Remove the installed cartridge from the housing cradle. Disconnect the reagent supply line by detaching the PEEK nut from the inlet at the top of the cartridge. (The reagent supply line for the *Acid* reagent cartridge is labeled *Acid*. The reagent supply line for the *Oxidizer* reagent cartridge is labeled *Oxidizer*.)

Insert the PEEK nut plug (saved from the last time the reagent cartridge was replaced) into the inlet nozzle of the cartridge.

6. Repeat the steps [4](#) and [5](#) for the *Oxidizer* reagent cartridge.
7. Set aside the reagent cartridges to dispose of according to federal, state, and local government regulations.
8. If replacing both cartridges, start with the *Acid* reagent cartridge. Inside the Analyzer, locate the reagent supply line with the label that matches the cartridge being replaced. (The reagent supply line for the *Acid* cartridge is labeled *Acid*. The reagent supply line for the *Oxidizer* cartridge is labeled *Oxidizer*.) Attach the supply-line PEEK nut to the inlet at the top of the *Acid* reagent cartridge and tighten finger tight.
9. Slide the green button on the nozzle inlet in to open the valve.
10. Repeat steps [8](#) and [9](#) to connect the *Oxidizer* reagent cartridge.
11. Place the *Acid* reagent cartridge into the back compartment of the reagent housing, positioning the cartridge horizontally with the tubing-end facing toward the right and open-side of the housing.
12. Place the *Oxidizer* reagent cartridge into the front compartment of the reagent holder, positioning the cartridge horizontally with the tubing-end facing toward the right and open-side of the housing.
13. Carefully lower the reagent housing cover over the reagents, sliding the guide pin (located toward the back and on top of the reagent housing) through the guide hole on the cover.

Also, make sure that the two tubing lines are carefully positioned between the cover and cradle-side cushions of the housing.

14. Tighten the thumbscrews on the reagent housing cover to secure.

15. Close and latch the door to the Analyzer.
16. After replacing an *Acid* and/or *Oxidizer* reagent cartridge, record the installation on the *Consumables* tab of the *Maintenance* screen. In the appropriate *Acid* or *Oxidizer* section, press **RENEW**. For more information refer to [“To renew an expiration date” on page 185](#).

Replacing other Consumables

Use the following step-by-step instructions to replace the following general consumable items:

- [“To replace the resin cartridge” on page 195](#)
- [“To replace the UV Lamp” on page 200](#)
- [“To replace the sample pump heads” on page 202](#)
- [“To replace the in-line filter element” on page 205](#)

Before installing new consumables, ensure the following:

- Analysis is stopped.
- The operating system is shut down, the Analyzer power switch is Off, and the power cord is disconnected (*Laboratory and Portable TOC Analyzers*) or Mains is off (*On-Line TOC Analyzer*).

To replace the resin cartridge

This process includes installing the resin cartridge into the *Prime* position to prepare for priming the DI pump, priming the DI pump, and installing the resin cartridge into the *Run* position.

1. Remove the installed resin cartridge. Simultaneously press the latches on the *Run* port and the *DI Pump Outlet* port to release the cartridge and pull away. Set aside the resin cartridge for proper disposal according to local area regulations.

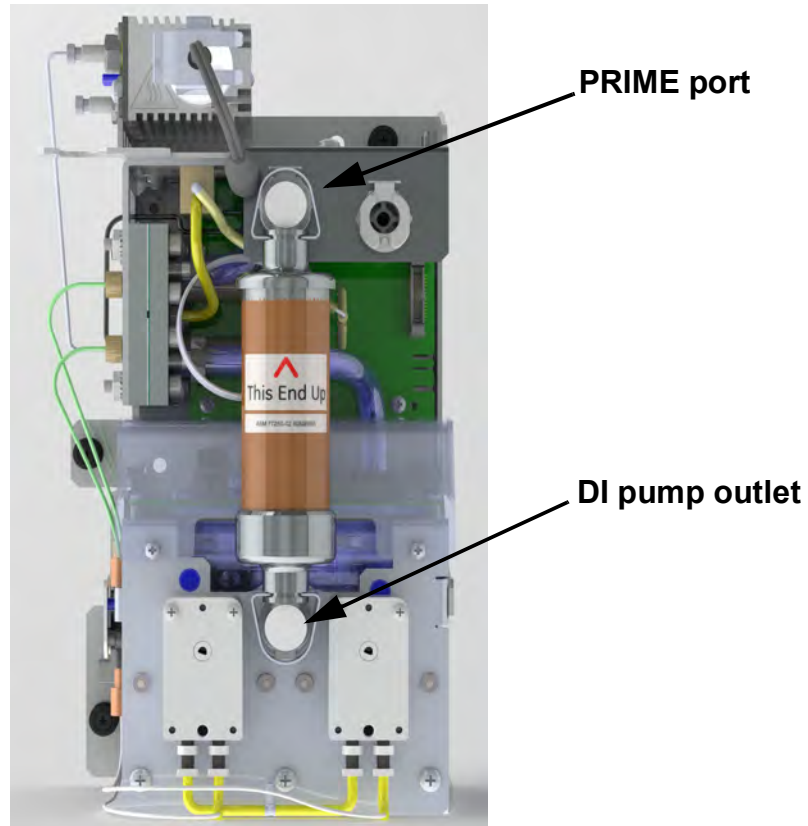

2. Install the new resin cartridge. Simultaneously, insert one elbow-fitting end of the cartridge into the *Prime* port and the other elbow-fitting end into the DI pump outlet.

Verify that the ends are secure before moving to the next step.

3. Press the Analyzer's power switch to the **ON** position, and let the Analyzer run three hours to allow the DI pump to circulate water in the DI loop.
4. After three hours, on the *Home* screen, press the **SHUT DOWN** button  located in the lower-right portion of the screen. The *Shutdown System* dialog box appears.

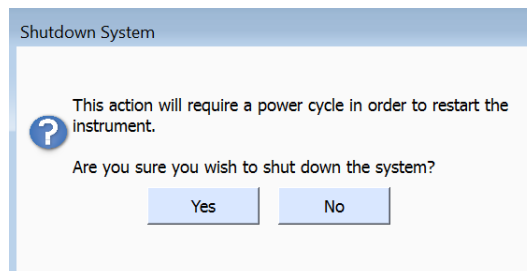

5. Press **YES** to confirm.
6. Turn the power switch to the **OFF** position.

7. View the reservoir water level and verify that the water level reaches **just below** the top of the reservoir.

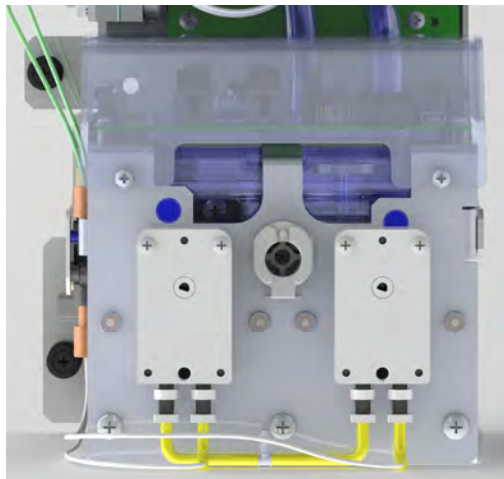

8. The water level may now be lower as water will circulate in the DI loop and saturate the resin cartridge during the priming process. Fill the DI reservoir with water, if needed, repeating the procedure [“To fill the DI water reservoir” on page 212](#). There is no need to prime the DI pump again.
9. After verifying that the water level has stabilized to **just below** the top of the reservoir, remove the top valve of the resin cartridge from the prime position. While holding the DI cartridge, simultaneously press the latches on the *Prime* port and the *DI Pump Outlet* port to eject the cartridge. See [Figure 52 on page 198](#).
10. Install the resin cartridge into the *Run* position. Simultaneously, insert the elbow-fitting ends of the cartridge into the *Run* port and the *DI Pump Outlet* port. Hold the cartridge tightly in place.

Verify that the ends are secure before moving to the next step.
11. Close and latch the Analyzer’s door (*On-Line TOC Analyzer*) or replace the panel (*Laboratory and Portable TOC Analyzers Only*).
12. Renew the installation date of the resin cartridge in the Analyzer using the *Consumables* tab on the *Maintenance* screen. For detailed instructions, see [“To renew an expiration date” on page 185](#).

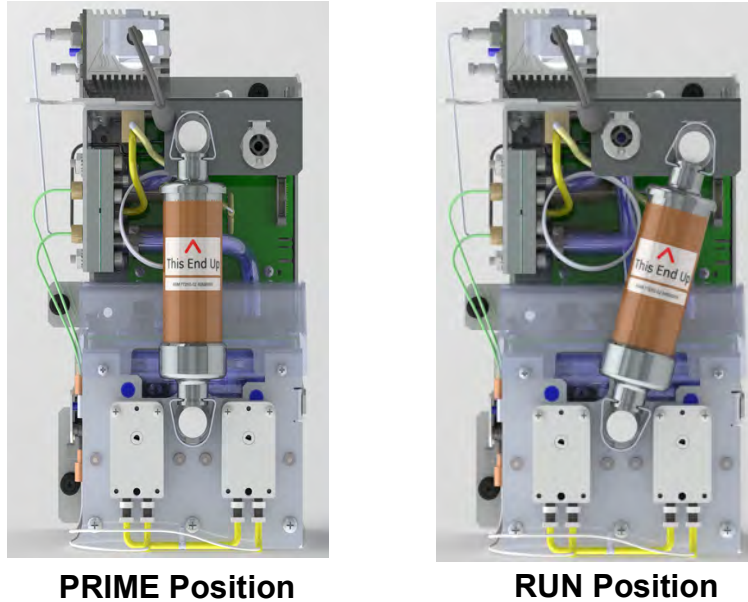

Figure 52: Resin Cartridge — “Prime” and “Run” Positions

13. If this replacement of the resin cartridge is part of the annual (12-month) service, replace the other consumables (UV lamp and pump heads), and then perform the annual calibration activities.

If this replacement of the resin cartridge is unscheduled, we recommend TOC verification. Calibrate if necessary.

To drain excess water from the DI water reservoir

If the DI water reservoir (white) float indicates that excess water is in the DI reservoir, drain the excess water.



NOTE: The float should be just below the top of the reservoir. Do not overfill ([Figure 53](#)).

1. Stop any analysis and ensure that the power to the Analyzer is off and disconnected from its power source.
2. Locate the Dispensing bottle (with attached filling fixture) and the extra elbow fitting from the Analyzer Accessories Kit.
3. Insert the extra elbow fitting into the *Run* port (**A**).

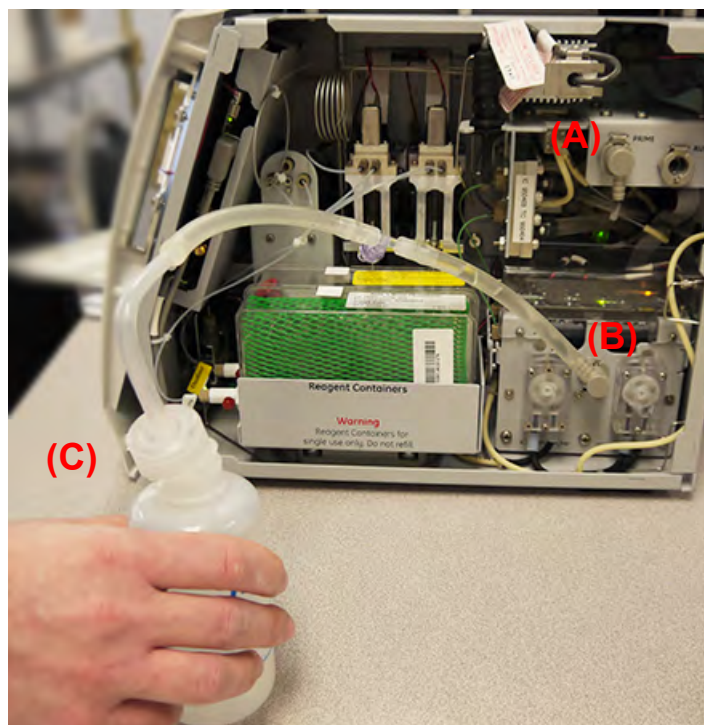

4. Insert the elbow-fitting end of the filling fixture (now attached to the dispensing bottle) into the *DI pump* outlet **(B)**. (The outlet is located between the IC and TC sample pumps.)
5. Loosen the lid of the dispensing bottle **(C)**.
6. Turn the Analyzer power switch to **On**. The DI reservoir will automatically start to drain into the bottle.
7. When finished draining the excess water, shut down and power off the Analyzer.
8. Verify that the water line is **just below** the top of the reservoir ([Figure 53](#)). Add water as needed. See [“To fill the DI water reservoir” on page 50](#)).

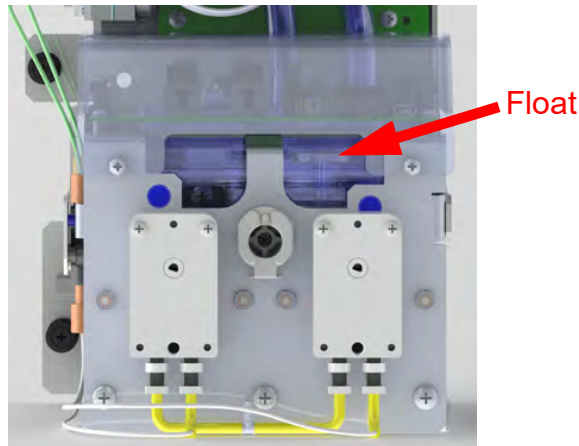

Figure 53: Water Reservoir with Float

9. Press the latch of the *DI pump* outlet up and detach the elbow-fitting end of the filling fixture from the *DI pump* outlet **(B)**.

To replace the UV Lamp

Replace the UV lamp every six months.



NOTE: A cotton glove to be worn during the installation is included with the replacement UV lamp to avoid leaving fingerprints on the lamp.

1. Allow the reactor to cool for at least 30 minutes before removing the previously installed UV lamp.
2. Open the Analyzer and locate the UV lamp enclosure. Refer to [“Interior Views of the Analyzer” on page 176](#), if needed.
3. Disconnect the (black) power connector **(A)** from the power supply by turning the connector and carefully pulling the plug out.

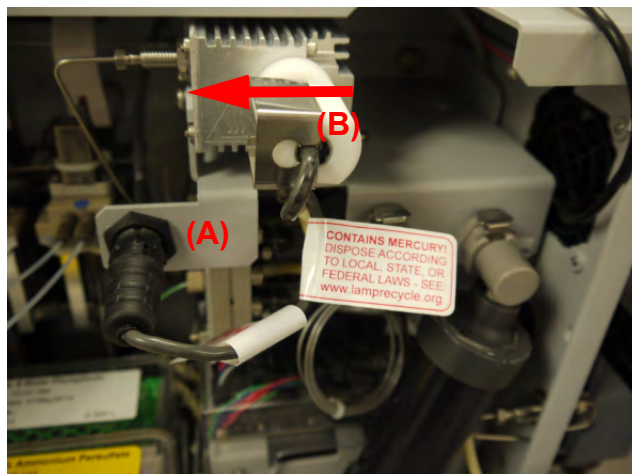

4. Slide the metal bracket to the left and off the (white) thermal mount (B). Set it aside for the reassembly process.
5. Gently pulling on the cord, slowly slide the UV lamp out of the enclosure. Keep the lamp as straight as possible so as not to break it. Set it aside for proper disposal according to local regulations.

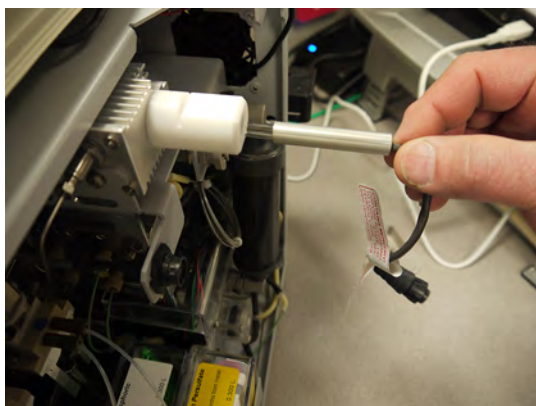

6. Open the end of the UV lamp shipping package without touching the UV lamp.
7. Put on the cotton glove (provided with the replacement kit) and carefully remove the new UV lamp from its packaging.
8. Carefully slide the lamp assembly (lamp end first) into the (white) thermal mount. Keep the lamp as straight as possible so as not to break it. Stop when the metal end is flush with the end of the thermal mount.
9. Slide the metal bracket onto the thermal mount.
10. Reconnect the black power connector from the power supply. Line up the pins and groove and insert the plug. Turn the connector 1/4 turn to secure the plug.
11. Loop the excess cord of the power connector under the restraining clip of the thermal mount bracket (C).

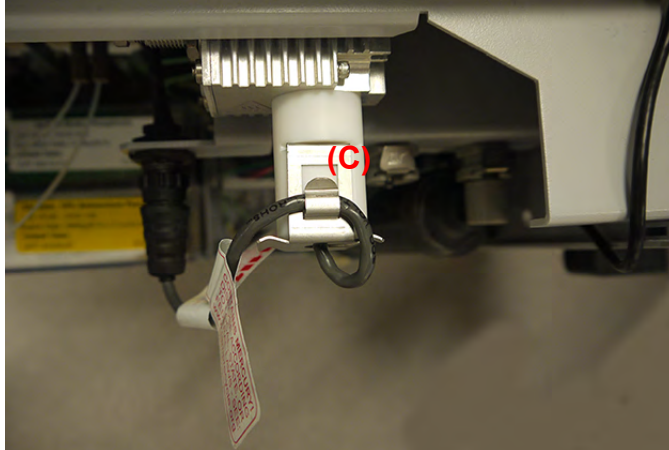

12. Re-establish power to the Analyzer.
13. Renew the installation date of the UV lamp in the Analyzer using the *Consumables* tab on the *Maintenance* screen. For detailed instructions, see [“To renew an expiration date” on page 185](#).
14. If this replacement of the UV lamp is part of the 6-month service, we recommend TOC verification. Use the concentration defined in the Standard Operating Procedures as the verification level. Calibrate if needed.

If this replacement of the UV lamp is part of the annual (12-month) service, replace the other consumables (pump heads and resin cartridge), and then perform the annual calibration activities.

If this replacement of the UV lamp is unscheduled, we recommend TOC verification. Use the concentration defined in the Standard Operating Procedures as the verification level. Calibrate if necessary.

To replace the sample pump heads

Sample pump tubing needs to be replaced every 12 months. This involves replacing the entire sample pump head. The IC and TC sample pumps are replaced on the same frequency schedule. However, follow the steps to replace one sample pump at a time to help more easily identify and keep track of the TC and IC inlets.



NOTE: Place a paper towel nearby to soak up minor spilling during this installation process.

1. Temporarily remove the resin cartridge to provide more room while working in this area. Simultaneously press the latches on the *Run* port and the *DI Pump*

Outlet port to release the cartridge and pull it away. Set aside the resin cartridge.

2. Open the Analyzer and locate the two sample pump heads [Figure 54](#). Refer to [“Interior Views of the Analyzer” on page 176](#) if needed.
3. To remove the TC pump head, disconnect the right *inlet* tubing coming out of the pump head from the fitting at the end of the TC waste tubing **(A)**, [Figure 54](#).

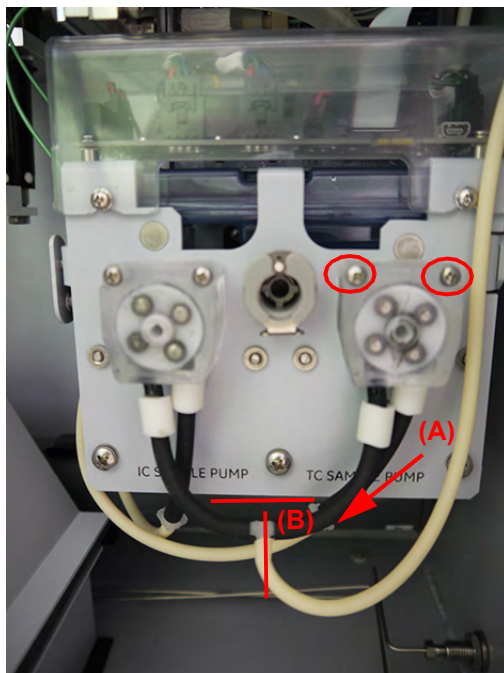

Figure 54: Sample Pump Heads and Tubing — TC Side

4. Disconnect the left *outlet* tubing coming out of the sample pump head from the T-connector **(B)**, [Figure 54](#).
5. Using a Phillips-head (crosshead) #1 screwdriver, remove the two screws from the TC sample pump head. Pull the sample pump head off the shaft. Discard the pump head according to local regulations.
6. Locate one of the new sample pump heads from the replacement kit. Notice that the hole in the middle has one flat side. The shaft also has one flat side. Line up the hole with the shaft when installing.
7. Position the pump head in your hand so that the side with recessed screw holes faces away from the instrument.
8. Insert the center hole of the new sample pump head over the shaft, lining up the flat side of the shaft and hole. You may need to rotate the pump head to fit over the shaft.

Chapter 7 MAINTENANCE

After the pump head is inserted over shaft and is flush with the sheet metal, you may need to rotate the pump head into its final position. The flat top of the pump head should be positioned in a horizontal line and the tubing should be located at the bottom of the pump head.

9. Replace the screws, securing the pump head to the Analyzer.
10. Connect the left tubing end to the T-fitting **(B)**, [Figure 54](#).
11. Connect the right tubing end to the TC waste tubing **(A)**, [Figure 54](#).
12. Now replace the IC pump head. Disconnect the right *inlet* tubing coming out of the pump head from the fitting at the end of the IC waste tubing **(C)**, [Figure 55](#).

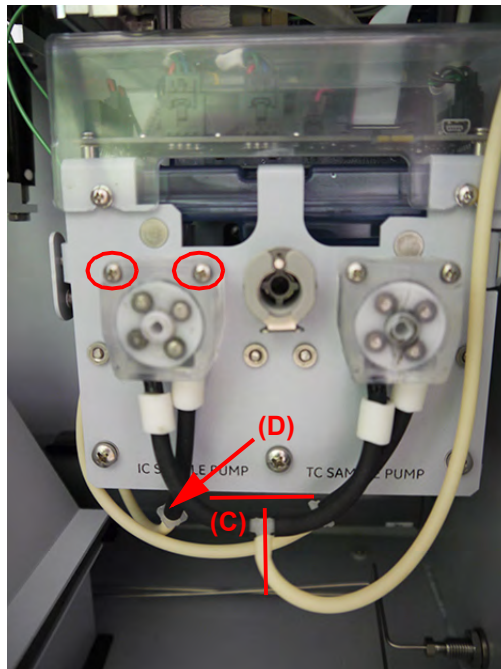

Figure 55: Sample Pump Heads and Tubing — IC Side

13. Disconnect the left *outlet* tubing coming out of the pump heads from the T-connector **(D)**, [Figure 55](#).
14. Using a Phillips-head (crosshead) #1 screwdriver, remove the two screws from the IC sample pump head. Pull the pump head off the shaft. Discard the pump head according to local regulations.
15. Locate the other new sample pump head from the replacement kit and position the pump head in your hand so that the side with recessed screw holes faces you.
16. Insert the center hole of the new sample pump head over the shaft, lining up the flat side of the shaft and hole. You may need to rotate the pump head to fit over the shaft.

- Ensure that the pump head is flush with the sheet metal.
17. Replace the screws, securing the pump head to the Analyzer.
 18. Connect the left tubing end to the T-fitting **(C)**, [Figure 55](#).
 19. Connect the right tubing end to the IC waste tubing **(D)** [Figure 55](#).
 20. Replace the resin cartridge.
 21. Renew the installation date of the sample pump heads in the Analyzer using the *Consumables* tab on the *Maintenance* screen. For detailed instructions, see [“To renew an expiration date” on page 185](#).
 22. If this replacement of the sample pump heads is part of the annual (12-month) service, replace the other consumables (resin cartridge and UV lamp), and then perform the annual calibration activities.

If this replacement of the sample pump heads is unscheduled, we recommend TOC verification. Calibrate if necessary.

To replace the in-line filter element

To prevent clogging in on-line configurations, a filter is used on the sample inlet line. The lifetime of the filter element depends on the level of particles in the water samples.



Warning

Hazardous reagents (ammonium persulfate and phosphoric acid) are used in the Analyzer. The waste stream from the instrument is acidic and must be disposed of properly. Consult federal, state, and local government regulations.

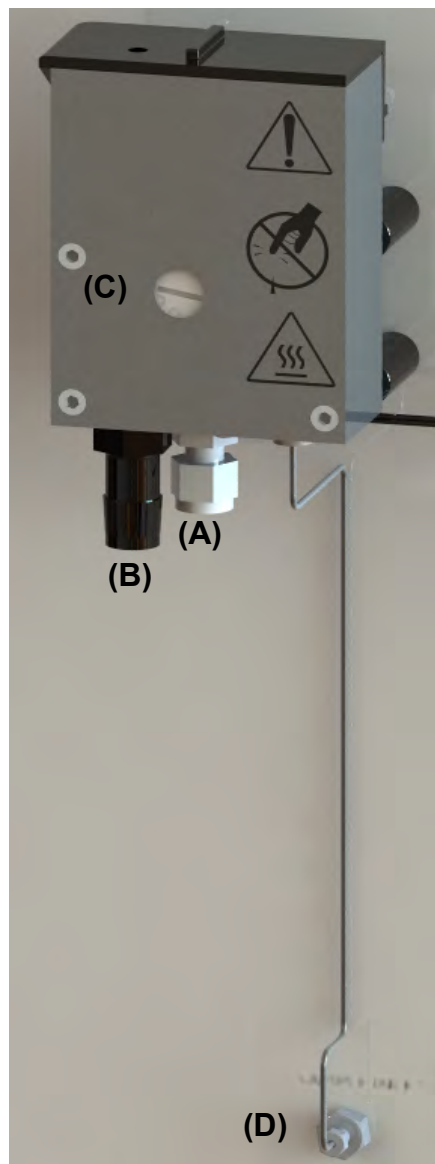

- (A) *iOS Sample Inlet*
- (B) *(Barbed) Waste Outlet Fitting*
- (C) *Flow Rate Adjustment Screw*
- (D) *Analyzer Sample Inlet*

Figure 56: iOS — One Stream

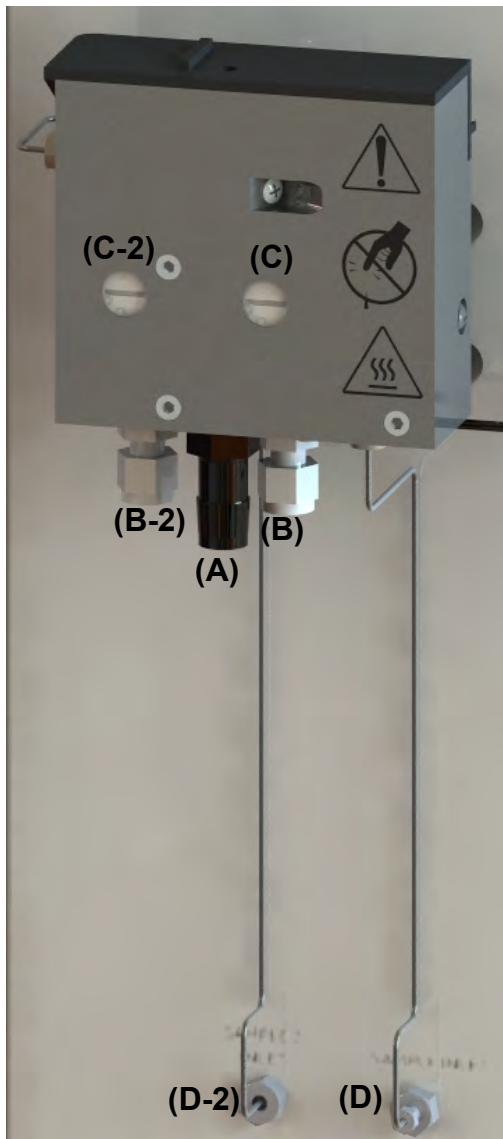

- (A) (Barbed) Waste Outlet Fitting
- (B) Stream 1 iOS Sample Inlet
- (B-2) Stream 2 iOS Sample Inlet
- (C) Stream 1 Flow Rate Adjustment Screw
- (C-2) Stream 2 Flow Rate Adjustment Screw
- (D) Stream 1 Analyzer Sample Inlet
- (D-2) Stream 2 Analyzer Sample Inlet

Figure 57: iOS — (Optional) Two Stream

1. Turn off the water.
2. Using a 9/16" open-end wrench, loosen the Swagelok fitting to remove the inlet tubing (with on-line filter) from the sample inlet **(B)**, [Figure 56](#), on the iOS System. Drain any remaining water left in the tubing.
3. If the Analyzer has the two-stream option, repeat the previous step for sample inlet **(B-2)**.
4. Disconnect each end of the installed filter from the tubing to remove it. Dispose of the filter according to local regulations.

Chapter 7 MAINTENANCE

5. Connect one end of the new filter to the inlet tubing for the water source and the other end of the filter to the inlet tubing for connecting to the Analyzer.
6. Reinstall the inlet tubing into the sample inlet **(B)**, [Figure 56](#), on the iOS System.

Position the capsule with the arrows (indicated on the outside of the filter) pointing toward the Analyzer. Water should flow through the filter in one direction.
7. Tighten the nut one-quarter turn past finger-tight.
8. If the Analyzer has the two-stream option, repeat steps [4](#) through [7](#) for the filter on the second inlet tubing configuration.
9. Ensure that the stainless steel tubing is connected to the bulkhead fitting, labeled *Sample Inlet* (installed at the factory).
10. Establish a water flow to the iOS System.
11. Adjust the flow to ≥ 50 mL/min using the flow rate adjustment screw **(C)**, [Figure 56](#).



NOTE: The flow rate is controlled by a needle valve, which can be adjusted by turning the screw located on the iOS. If the Analyzer has the two-stream option, there are two separate screws respective to each stream **(C)** and **(C-2)**. Turn the appropriate screw clockwise to decrease flow, or counter-clockwise to increase flow.

Warnings	
	(On-Line and Portable TOC Analyzers) Operation of the Analyzer without the in-line filter on the sample inlet line will damage the Analyzer and void the warranty.
	Always make sure the sample is flowing through the iOS System and the DI water reservoir is filled before starting analysis.

REPLACING ICR CONSUMABLES

Use the following instructions to replace ICR consumable items:

- “Replacing the ICR Degasser”
 - [“To replace the ICR Degasser \(Portable or Laboratory TOC Analyzer\)” on page 209](#)
 - [“To replace the ICR Degasser \(On-Line TOC Analyzer\)” on page 210](#)

Before installing new ICR consumables, ensure the following:

- Analysis is stopped.
- The operating system is shut down, the Analyzer power switch is Off, and the power cord is disconnected (*Laboratory and Portable TOC Analyzers*) or Mains is off (*On-Line TOC Analyzer*).

Replacing the ICR Degasser

To replace the ICR Degasser (*Portable or Laboratory TOC Analyzer*)

1. On the *Portable TOC Analyzer*, shut off any on-line sample streams and open the iOS system lid open to divert water from the ICR fluidics system.
2. Remove the right side panel (fluidics side of Analyzer) and locate the ICR inside the Analyzer. If needed, refer to [“Interior Views of the Analyzer” on page 176](#).
3. On the fluidics side of the Analyzer, remove the two knurled-nut tube connectors (1 and 2 in [Figure 58](#)) from the degasser. (Note the orientation of the tubing for the reassembly process.)

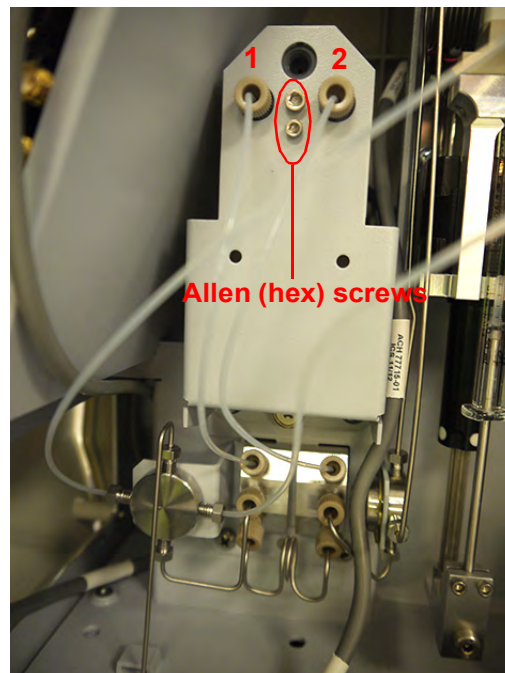

Figure 58: ICR Bracket

4. Loosen both the large and small Allen (hex) screws ([Figure 58](#)). Pull the installed degasser away and dispose of it according to local regulations.

Chapter 7 MAINTENANCE

5. Hold the new degasser in place next to the bracket and secure it with the large and small Allen screws.
6. On the fluidics side of the Analyzer, reconnect the two knurled-nut tube connectors (1 and 2 in [Figure 58](#)) on the degasser.
7. Replace the side panel.
8. On the *Portable TOC Analyzer*, close the iOS system lid and re-establish the on-line water flow.
9. Before resuming normal operation, perform several test measurements with the ICR option selected and check for any leaks in the sample stream.

To replace the ICR Degasser (*On-Line TOC Analyzer*)

1. Shut off any on-line sample streams and open the iOS system lid to divert water from the ICR fluidics system.
2. Open the door to the Analyzer and locate the degasser. If needed, refer to [“On-Line Analyzer Views” on page 176](#).
3. Remove the two knurled-nut tube connectors (1 and 2 in [Figure 59](#)) from the degasser. (Note the orientation of the tubing for the reassembly process.)

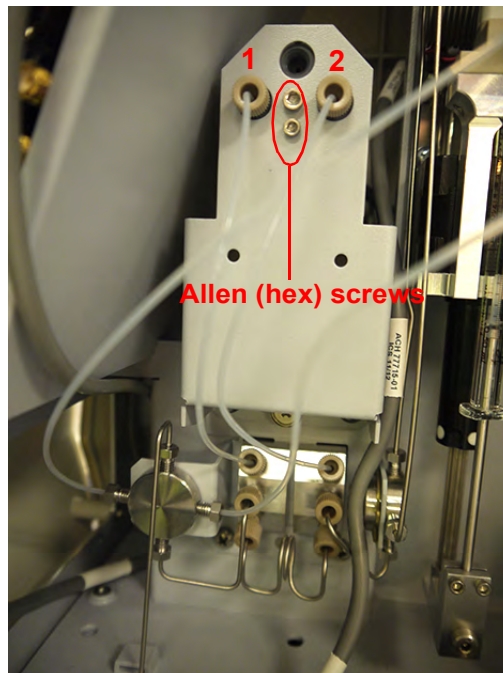

Figure 59: ICR Bracket

4. Loosen both the large and small Allen (hex) screws ([Figure 59](#)). Pull the installed degasser away from the ICR bracket. Dispose of the removed degasser according to local regulations.

5. Hold the new degasser in place next to the bracket and secure it with the large and small Allen screws.
6. Reconnect the two knurled-nut tube connectors (1 and 2 in [Figure 59](#)) to the degasser.
7. Replace the panel over the door electronics and secure with the screws.
8. Close the iOS system lid and re-establish the on-line water flow.
9. Before resuming normal operation, perform several test measurements with the ICR option selected and check for any leaks and proper operation.

PERFORMING ROUTINE MAINTENANCE TASKS

Instructions are included for the following routine maintenance tasks:

- [Flushing Reagent Syringes](#)
- [Maintaining the DI Water Reservoir Level](#)
- [Cleaning the Analyzer](#)

Flushing Reagent Syringes

If the Analyzer has not been used for over eight hours, the decomposition of persulfate can produce oxygen bubbles in the syringe pump and the reagent addition lines. To prevent bubbles from entering the sample stream and interfering in the TOC measurement, a reagent flush is used to remove the bubbles and fill the syringe with fresh reagent. A reagent (syringe) flush also is recommended after installing new chemical reagents.

To flush the reagent syringes

For on-line configurations, this requires access to a continuous water supply. If the Analyzer is configured for Grab mode, one 40-mL vial DI water is needed.

1. Do one of the following:
 - *On-Line Mode* — Make sure the Analyzer is connected to a continuous water supply of low-TOC deionized water.
 - *Grab Mode* — Insert a 40 mL vial of low-TOC deionized water into the iOS¹ System (*On-Line or Portable Analyzer*) or Vial Port (Laboratory Analyzer).
2. On the *Maintenance*  screen, select the *Advanced* tab.

¹. Make sure the stainless steel tubing from the iOS system is connected to the *Sample Inlet* port.

Chapter 7 MAINTENANCE

3. Press **SYRINGE FLUSH**. The *Syringe Flush* dialog box appears.



4. Press the *Number of Times to Move Syringe* field and use the numeric keypad to enter a value and press **OK**.
5. Press **FLUSH**. The remaining flush time appears on the dialog box.
6. When the flush completes and the counter reaches **00:00:00**, press **CLOSE**.
7. If a vial was used for the flush, remove it now.

Maintaining the DI Water Reservoir Level

Check the DI water reservoir level when replacing reagents or the UV lamp and fill the reservoir, as needed.



NOTE: *It is important to ONLY fill the reservoir to the suggested level. If you do overfill the reservoir, drain the excess water by following the troubleshooting procedure, [“To drain excess water from the DI water reservoir”](#) on page 214.*

To fill the DI water reservoir

1. Locate the following in the Analyzer’s Accessories Kit:
 - Dispensing bottle
 - Filling fixture [Two lengths of tubing (one with an elbow fitting) and a T-fitting]
2. Fill the bottle with DI water.
3. Insert the elbow-fitting end of the filling fixture into the *Prime* outlet. ([Figure 60](#)).

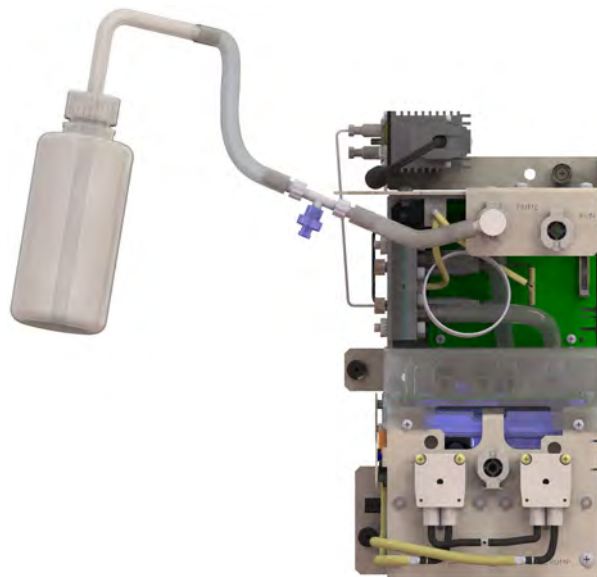

Figure 60: Filling the DI Pump

4. Squeeze the bottle to fill the DI reservoir until the water line reaches **JUST BELOW** the top of the reservoir. Use the float seen through the window as a guide, as shown in [Figure 61](#).

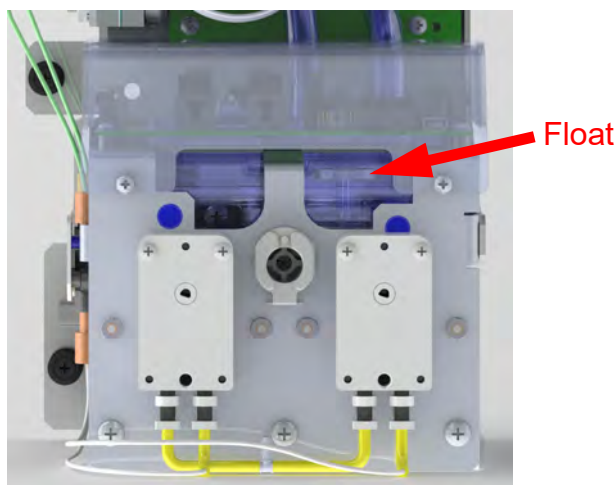

Figure 61: DI Reservoir Level with Float



NOTE: It is important to **ONLY** fill the reservoir to the suggested level. Otherwise, the water in the viewable portion of the reservoir may overflow to another level in the reservoir (which is not viewable from the window). If you do overfill the reservoir, drain the excess water by following the troubleshooting procedure, [“To drain excess water from the DI water reservoir”](#) on page 198.

Chapter 7 MAINTENANCE

5. Press the latch of the *DI pump* outlet up to release the dispensing bottle's elbow-fitting for removal of the dispensing bottle accessory.

To drain excess water from the DI water reservoir

If when filling the DI water reservoir the float indicates that excess water is in the DI reservoir, drain the excess water.

1. Stop any analysis and ensure that the power to the Analyzer is off and disconnected from its power source.
2. Locate the Dispensing bottle (with attached filling fixture) and the extra elbow fitting from the Analyzer Accessories Kit.
3. Insert the extra elbow fitting into the *Run* port **(A)**.

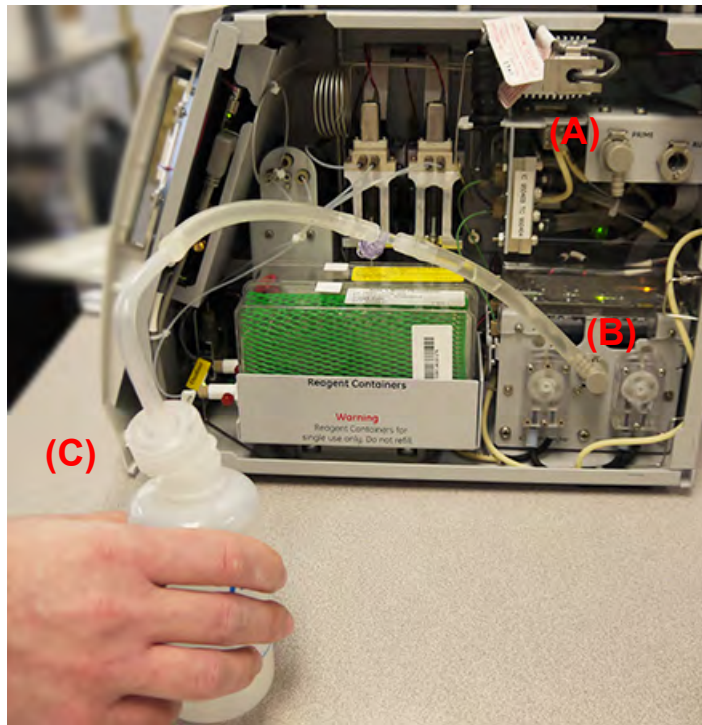

4. Insert the elbow-fitting end of the filling fixture (now attached to the dispensing bottle) into the *DI pump* outlet **(B)**. (The outlet is located between the IC and TC sample pump heads.)
5. Loosen the lid of the dispensing bottle **(C)**.
6. Turn the Analyzer power switch to **On**. The DI reservoir will automatically start to drain into the bottle.
7. When finished draining the excess water, shut down and power off the Analyzer.

8. Verify that the water line is JUST BELOW the top of the reservoir, as shown in [Figure 61: DI Reservoir Level with Float](#). Add water as needed. See [“To fill the DI water reservoir” on page 212](#).
9. Press the latch of the *DI pump* outlet up and detach the elbow-fitting end of the filling fixture from the *DI pump* outlet **(B)**.

Cleaning the Analyzer

When replacing consumables, clean the Analyzer's external housing and touchscreen as part of routine preventative-maintenance schedule.

To clean the external housing

Obtain a clean, soft cloth dampened with water or a non-abrasive cleaner, and another clean *dry* soft cloth.

1. Turn *off* power to the Analyzer and disconnect it from the main power source.
2. Wipe the external housing with a clean cloth dampened with water or a non-abrasive cleaner.
3. Wipe dry with another clean and *dry* soft cloth.

To clean the touchscreen

Obtain a clean, soft (and *dry*) cloth or cotton pad.

1. Disable the screen for cleaning. On the *Maintenance*  screen, select the *Advanced* tab.
2. Press **CLEAN SCREEN** to temporarily disable the screen for 30 seconds. Repeat, as needed, if the 30-second time frame expires while cleaning.
3. Wipe the touchscreen with a clean, soft (and *dry*) cloth or cotton pad.

THIS PAGE IS INTENTIONALLY LEFT BLANK.

8

TROUBLESHOOTING

OVERVIEW

This chapter provides the starting point for troubleshooting basic issues with the Analyzer. For additional assistance, see [“Step 5: Obtain Technical Support” on page 248](#).

This following applies to all Sievers M-Series models, except where noted.

STEP 1: REVIEW FAILURES, WARNINGS, AND ERRORS

The Analyzer automatically runs *Self Check* activities when starting up and provides a summary for reviewing failures. This section includes common failures and troubleshooting suggestions.

The first step in troubleshooting is to review the Warnings and Errors list. For an explanation of warning and errors, refer to [Appendix E. “Warning and Error Descriptions.”](#)

This section includes instructions for:

- [“Reviewing the Self Check Summary” on page 217](#)
- [“Reviewing Errors and Warnings” on page 218](#)

Reviewing the Self Check Summary

When turning on the power to the Analyzer, the Analyzer performs various *Self Check* activities. The *Self Check* dialog box [Figure 62: Self Check Dialog Boxes](#) automatically appears on the Analyzer screen showing the progress of the *Self Check*. At the conclusion of the *Self Check* activity, the Analyzer reports if the check passed (**GREEN CHECK MARK**) or failed (**RED X**), and offers a choice to view the *Self Check Summary* dialog box, which gives more details that may be helpful in the troubleshooting process.

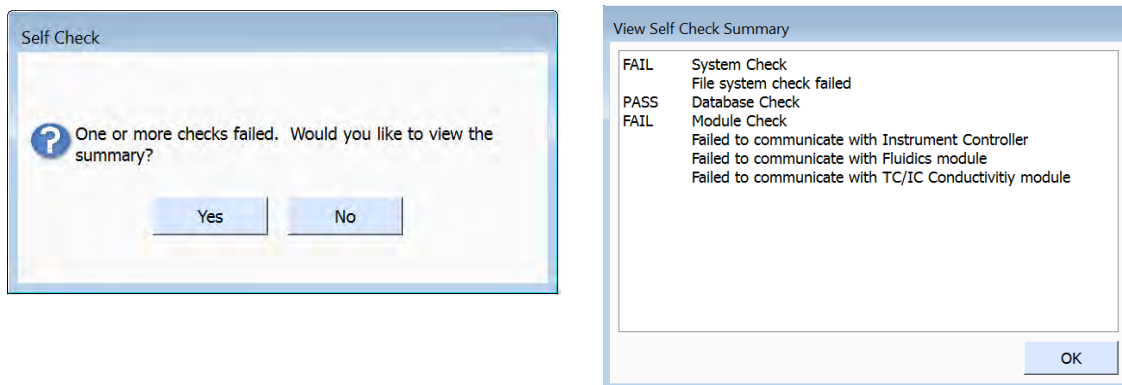

Figure 62: Self Check Dialog Boxes

The Analyzer performs the following *Self Check* activities:

- **System Check** — Checks the general status of the operating system and performs a file system check. If this check fails, one cause may be that the data card has not been inserted correctly. Try reinserting the data card and ensure that it is making contact in the slot.

The Analyzer then checks that the application directory is current and that the system clock is set. A system clock error may occur when first starting the Analyzer. Set the system clock and restart the Analyzer.

The Analyzer also performs a check of USB and Ethernet connections. If either of these fail, check that the connections are secure.

- **Database Check** — Issues an SQL command to count the number of records in each database table and reports an error condition if the system was unable to read the database table. When the system is started for the first time, there are no database tables in the system. Therefore, the Analyzer will likely report a failure. Try restarting the instrument to see if solves the issue.
- **Module Check** — The Analyzer verifies that each hardware module is connected and communicating. The Analyzer will report any modules that the application controller is unable to communicate with. Examine the instrument controller board (to locate the board, reference [“Interior Views of the Analyzer” on page 176](#)) and correct any loose connections to the reported module(s). For additional help, contact Technical Support or your local service provider.

Reviewing Errors and Warnings

To review errors and warnings

Use the *Error History* tab on the *Maintenance* screen to search and view the list of errors and warnings. After filtering the list, return to the full list of errors and warnings by pressing **RESET**.



NOTE: If the display **and** all other outputs of warnings for consumables have been disabled, these warnings will appear **only** on the Error History tab. For more information, see [“To set preferences for warnings” on page 122.](#)

1. On the Maintenance screen, select the *Error History* tab.

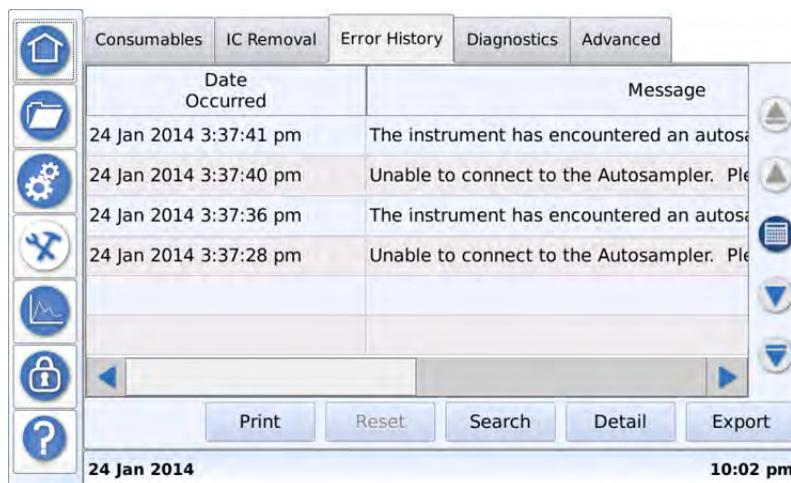

2. Review the list of messages (listed most recent to earliest). To scroll through any additional pages of messages:
 - Use the **UP** and **DOWN** arrows to skip forward or in reverse chronological order by a page.
 - Use the **START** and **END** arrows to take you to the most recent or earliest message (respectively).
3. To search for messages of a specific date, press the **CALENDAR** icon to display the *Calendar* dialog box. Use the navigation arrows (as needed) to locate the date and press the day to view.
4. To search for messages by a keyword, USER ID, and/or occurrence date, press **SEARCH** to display the *Search* dialog box. Select from the options and enter criteria. Press **SEARCH** to filter the list.



NOTE: Toggle the **AND** button to **OR** as needed. Press inside the *Keyword* field to use the alpha/numeric keypad to enter a word (or string of words) to find.

Chapter 8 TROUBLESHOOTING

5. To view additional details of any message, select the message line and press **DETAIL**. The *Detail* dialog box appears.

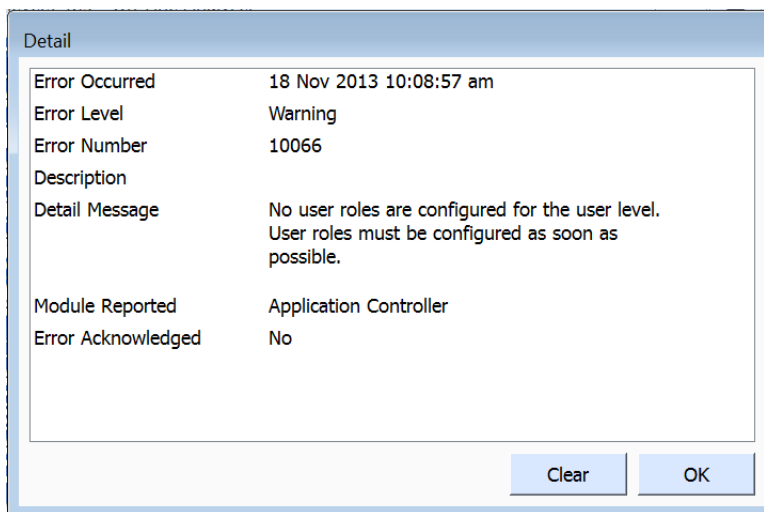

The screenshot shows a dialog box titled "Detail" with the following information:

Error Occurred	18 Nov 2013 10:08:57 am
Error Level	Warning
Error Number	10066
Description	
Detail Message	No user roles are configured for the user level. User roles must be configured as soon as possible.
Module Reported	Application Controller
Error Acknowledged	No

At the bottom right of the dialog box, there are two buttons: "Clear" and "OK".

If the warning or error has not yet been acknowledged, the **CLEAR** button appears active. To acknowledge the warning or error and return to the *Error History* tab, press **CLEAR**.

6. To return to the *Error History* tab without acknowledging the warning or error, Press **OK**.
7. To print the list, press **PRINT**. Press **OK** to return to the *Error History* tab.



NOTE: The Analyzer prints only non-acknowledged errors and warnings.

8. To export the list (all warnings and errors), insert a USB memory drive into one of the Analyzer's USB Host ports. Enter any additional search filters and press **EXPORT**. After the *In Progress* dialog box reports completion, press **CLOSE** to return to the *Error History* tab.

STEP 2: VISUAL INSPECTION

After confirming that there are no warning or error messages indicating a specific problem, proceed to a visual inspection of the Analyzer to identify any obvious physical problems or symptoms. Begin with an external visual inspection, and proceed to an internal visual inspection. If possible, perform the inspection while the Analyzer is analyzing so you can verify that relevant modules are performing with typical operation.

Perform an external and internal visual inspection as follows. (Refer to [“Interior Views of the Analyzer” on page 176](#), as needed.)



Performing an External Inspection

Look at the outside of the Analyzer for the following:

Confirm that there are no leaks present at the *Sample Inlet* port or the waste connections.

- If the Analyzer is taking measurements, confirm that water is flowing from the waste outlet.
- If experiencing erratic TOC readings, confirm that the pH of the waste stream is <4. (Refer to [“pH of Waste Stream is Too High” on page 237](#) for details).
- Confirm that all cables are securely attached to the Analyzer.
- (*On-Line and Portable TOC Analyzers*) If sampling from 40 mL vials, confirm that the needle in the iOS System is not obstructed. Loosen the fitting at the *Sample Inlet* port and check that water flows out of the stainless steel tubing when water is in the iOS System.

Performing an Internal Inspection

Warning	
	<p>Any operation requiring access to the inside of the Analyzer could result in injury. To avoid potentially dangerous shock do this. BEFORE opening the Analyzer, stop any analysis and shut down the operating system (using the SHUT DOWN button on the <i>Home</i>  screen) BEFORE turning the power switch to OFF.</p>

Look inside the Analyzer for the following:

- Check for water or reagent leaks throughout the Analyzer. There should not be moisture on the inside floor of the Analyzer housing.
- Confirm that the valves on clear-type reagent cartridges are open.
- Check the reagent syringes to make sure no large air bubbles are present. Also inspect the syringes for leaks and confirm that the plunger moves during analysis. If bubbles are present, perform a reagent flush.
- Conduct a test to confirm that the sample pumps are turning (refer to [“To check the sample pumps” on page 229](#)). If the pumps are turning, sample should be flowing from the waste stream.
- Check to make sure there are no leaks in the DI system, especially at valves and the stream splitters ([Figure 63](#)).

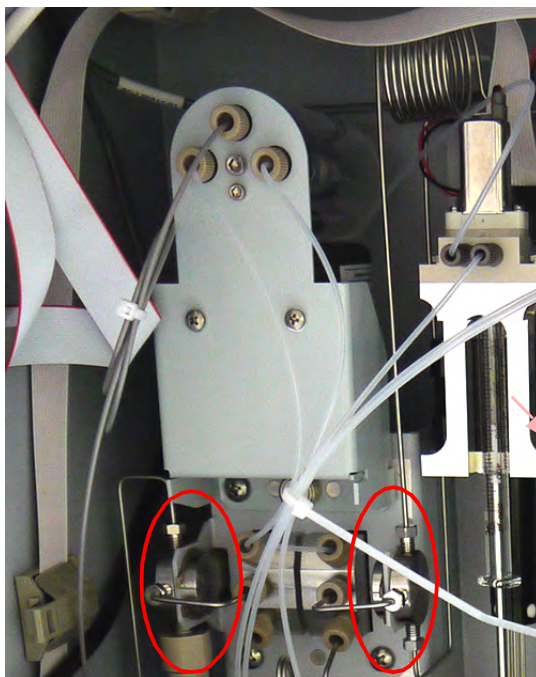

Figure 63: Stream Splitters and Valves

- Confirm that the DI water reservoir is filled to the proper level by observing the float disk in the DI reservoir. Remove the resin cartridge to view, if needed. (See [“DI Reservoir Level with Float”](#) on page 51).
- If maintenance work has recently been performed on the Analyzer, confirm that electronics cables are securely attached.

STEP 3: REVIEW SOLUTIONS FOR BASIC PROBLEMS

If a visual inspection of the Analyzer does not help to identify the source of the problem, review and apply solutions presented in this section.

Reviewing Solutions for Basic Problems

CORRECTING MINOR SENSOR DIFFERENCES

If the Analyzer is returning unusually high IC or TC or negative IC or TC or conductivity values, a TC/IC Cell Conductivity Autozero may be necessary. If you have recently run a system protocol, let the Analyzer run for at least five hours before performing a conductivity Autozero.

To perform a TC/IC Cell Conductivity Autozero (optional)

1. If Password Protection is enabled, log in to the Analyzer with the appropriate User ID and password.
2. Stop (*Home* screen) or cancel (*Protocols* screen) any current analysis.
3. Back up the database for later reference. Insert a USB memory drive into one of the USB host ports and press the *Advanced tab*>**BACKUP DATABASE** on the *Maintenance* screen.
4. When the backup message indicates 100% completion, press **CLOSE**. Remove the USB memory drive and store for safekeeping.
5. On the *Protocols*  screen, select the *System Protocols* tab.

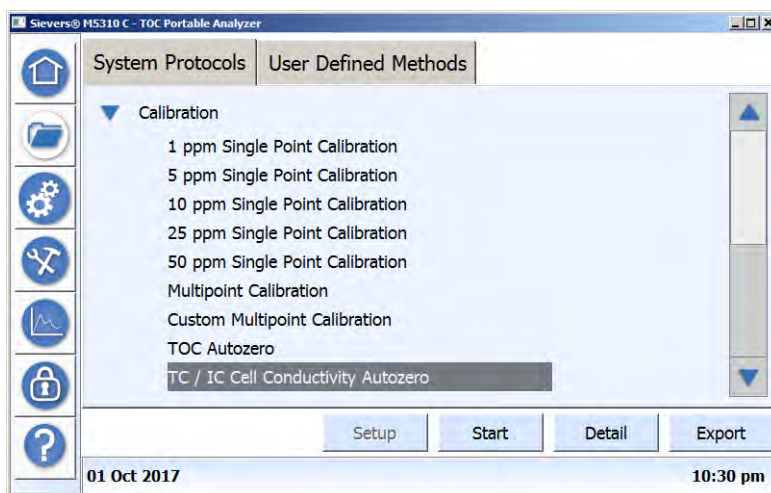

6. In the *Calibration* list, select **TC / IC CELL CONDUCTIVITY AUTOZERO** and press **START**. The *System Protocol: TC / IC Cell Conductivity Autozero* dialog box appears.

The Analyzer reports the number of seconds passing before the process completes. Wait for the TC / IC Cell Conductivity Autozero to complete.

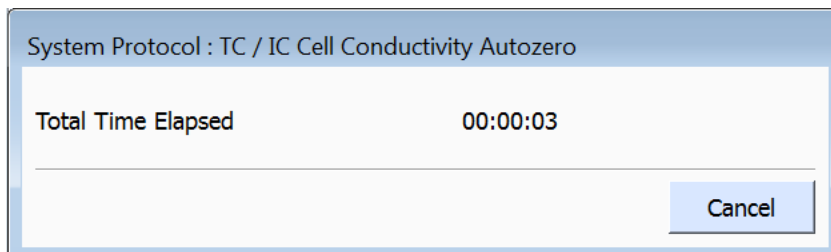

THE ANALYZER WILL NOT POWER ON

If the Analyzer will not power on, confirm that the power cord (*Laboratory and Portable TOC Analyzers*) is firmly seated at both ends. Also make certain that there is power to the outlet at the wall, surge protector, or circuit breaker. For the *On-Line TOC Analyzer*, check the breaker at the manifold. If these conditions are verified, the fuse in the power entry module on the back of the Analyzer may have blown.

To replace the fuse in the power entry module

Replace the fuse with the same type and rating: T1.6 A, 250 VAC (Slow Blow), size 5 x 20 mm appliance inlet.

1. Turn off the power to the Analyzer and disconnect the power supply cable (*Laboratory and Portable TOC Analyzers*) or Mains power supply (*On-Line TOC Analyzer*).
2. Using a small flat-head screwdriver, unsnap the cover of the power entry component forward to reveal the inserted fuse compartment.

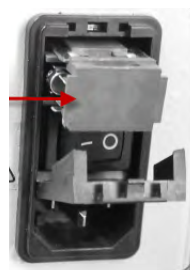

Figure 64: Power Entry Component with Fuse Compartment

3. Using the tip of the screwdriver, slide the (red) fuse compartment forward and remove the compartment.
4. Remove the blown fuse(s). (For the sake of convenience, you may want to remove and replace both fuses at this time).
5. Insert the new fuse(s). Ensure that the fuse is positioned toward the end and makes contact with the metal tab (extending up from inside the housing). Reference [Figure 65](#) as needed.

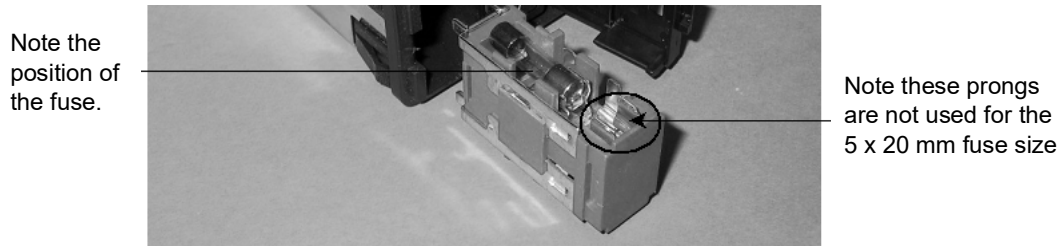

Figure 65: The Sievers Autosampler Fuse Housing

6. Slide the fuse compartment back into the Analyzer. (It does not matter which fuse is positioned on the top or bottom.)
7. Flip the cover of the power entry back into place.
8. Reconnect the power cable and restore power to the Analyzer
9. If the Analyzer still does not power on after replacing the fuse, contact Technical Support or your local service provider.

Chapter 8 TROUBLESHOOTING

CONNECTION PROBLEMS TO DATAPro2 SOFTWARE AND SIEVERS AUTOSAMPLER

(Non-starting or missing protocols, missing Analyzer icon, or “Autosampler” warnings or errors in DataPro2 Software)

(Laboratory and Portable Analyzers)

Use this procedure to re-establish connection between the Analyzer and the DataPro2 Software or, to re-establish connection between the Analyzer and the Sievers Autosampler.

To determine which connection type to re-establish, refer to the applicable problem in the following list, [Table 15](#).

TABLE 15: CONNECTION PROBLEM TYPES

<p>DataPro2 Software Connection Problems (Identified in the DataPro2 Software)</p> <ul style="list-style-type: none">• A protocol does not start after clicking RUN PROTOCOL• A missing Analyzer icon on the DataPro2 Software <i>Home</i> screen• Missing protocols on the DataPro2 Software <i>Favorites</i> screen^a
<p>Sievers Autosampler Connection Problems</p> <ul style="list-style-type: none">• “Autosampler” warnings or errors appearing in the DataPro2 Software <p>Note: Occasionally when power cycling the Sievers Autosampler while it is connected to the Analyzer, the Analyzer may lose the ability to communicate with the DataPro2 Software and the DataPro2 Software displays an “Autosampler” warning or error.</p>

- a. If Performance Qualification (validation) protocols are the only protocols missing in the DataPro2 Software Favorites screen, but other protocols are appearing on the *Favorites* screen, the optional Qualification Package — PQ may not have been activated on the *Configuration* screen. Refer to the *DataPro2 User Guide* for Qualification Package — PQ Protocol activation instructions.

To re-establish connection to DataPro2 Software or the Sievers Autosampler

1. Turn on power to the Analyzer.
2. After the *Home* screen appears, turn on power to the Sievers Autosampler.
3. Launch the DataPro2 Software on the computer.
4. On the *Maintenance*  screen, select the *Advanced* tab.
5. Press **AUTOSAMPLER CONNECTION**. The *Autosampler Connection* dialog box appears with two tabs.

- For DataPro2 Software connection problems (as described in [Table 15](#)), press the *DataPro2* tab. Otherwise go to step [8](#).

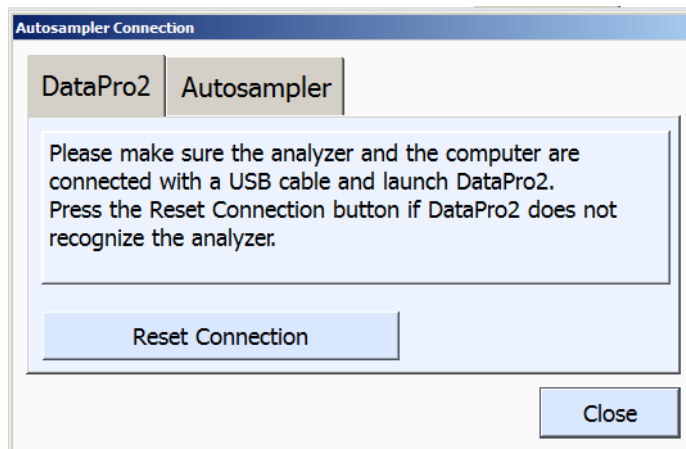

- Ensure the USB cable is securely connected at both ends (the port on the Analyzer and the port on the computer). Go to step [10](#).
- For Sievers Autosampler connection problems (as described in [Table 15](#)), press the *Autosampler* tab.

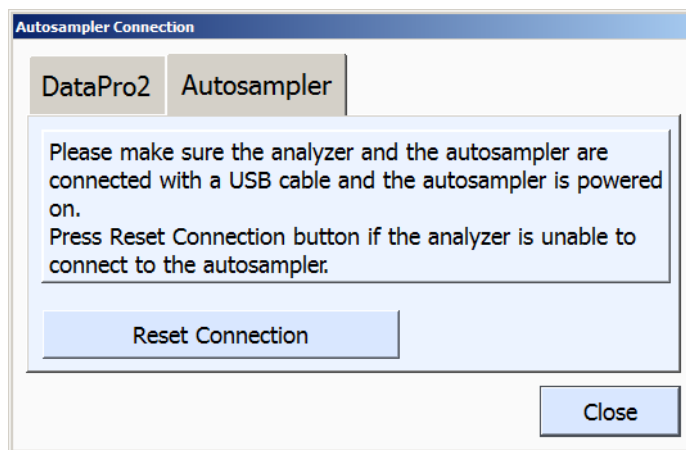

- With the Sievers Autosampler powered on, ensure the USB cable is securely connected at both ends (the port on the Analyzer and the port on the Sievers Autosampler).
- Press **RESET CONNECTION**.
- Press **CLOSE**. The connection is now re-established. If problems remain, contact Technical Support or your local service provider for help.

Chapter 8 TROUBLESHOOTING

CONNECTION PROBLEMS DIRECTLY FOLLOWING A SIEVERS AUTOSAMPLER INSTALLATION

If the Sievers Autosampler does not operate as expected, verify the communication cable connections.

To verify the Sievers Autosampler cable connections

1. Ensure that the communication cables for the Analyzer, Sievers Autosampler, and computer running DataPro2 Software are properly routed.

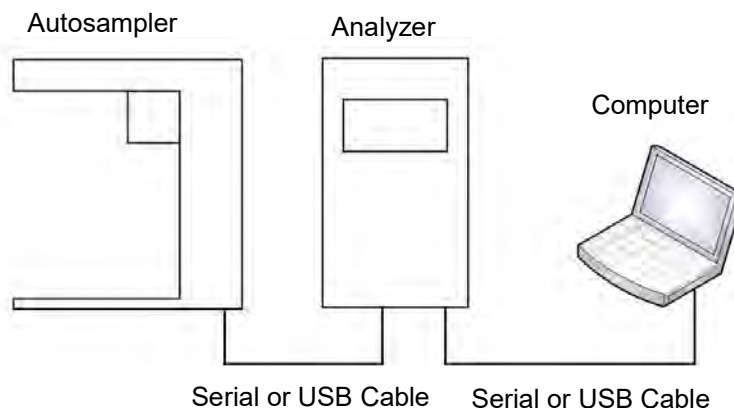

2. Remove and insert the USB cable connections used in the routing to ensure a tight connection.
3. If still unable to run Sievers Autosampler, re-establish connection to Sievers Autosampler as described in [“To re-establish connection to DataPro2 Software or the Sievers Autosampler” on page 226](#).

If experiencing any DataPro2 Software problems, such as missing or non-starting protocols, refer to [“Connection Problems to DataPro2 Software and Sievers Autosampler” on page 226](#).

PROBLEMS WITH THE DI PUMP

If the Analyzer is making a loud squealing sound or if water is not filling the tubing that leads to the resin cartridge, it is likely that the DI pump has not been properly primed. Prime the DI pump using the instructions in [“To prime the DI Water pump” on page 65](#).

LACK OF FLOW

To troubleshoot a lack of flow through the Analyzer, perform the following:

- [“To check the sample pumps” on page 229](#)
- [“To check the inlet tubing” on page 233](#)
- [“To prepare for the backflush” on page 233](#)
- [“To test the DI fluidics side for obstruction” on page 236](#)

Warning	
	<p>To avoid potentially dangerous shock, do not touch anything inside the Analyzer while performing these diagnostics.</p>

To check the sample pumps

1. Open the door (*On-Line TOC Analyzer*) or right panel (*Laboratory or Portable TOC Analyzers*) and locate the sample pumps ([Figure 66](#)). Refer to [“Interior Views of the Analyzer” on page 176](#), as needed.

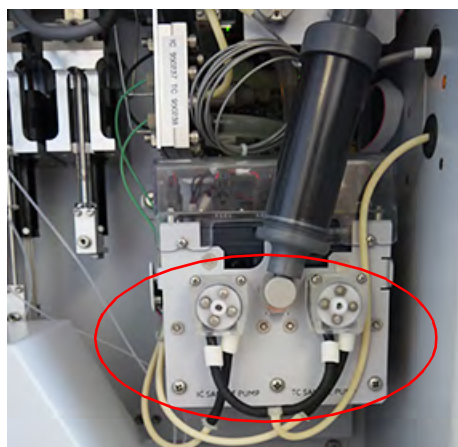
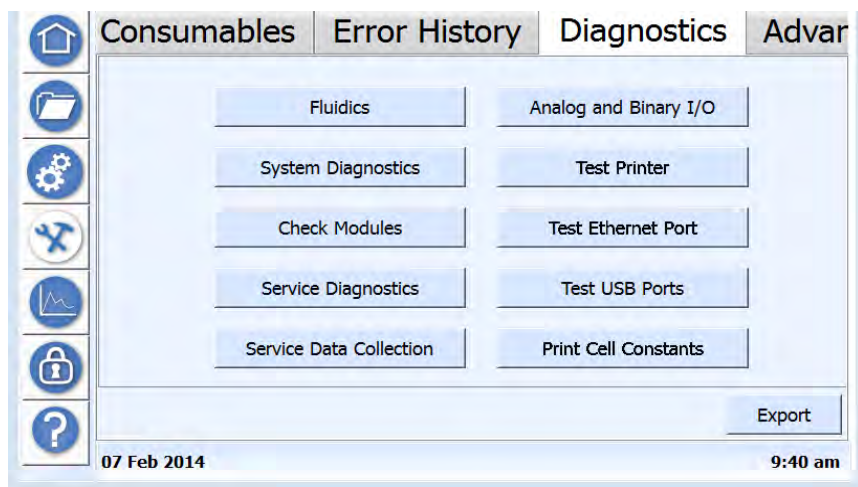

Figure 66: Sample Pumps

2. Set up the Analyzer for a grab mode sampling by removing the iOS stainless steel fitting from the Analyzer’s *Sample Inlet* port. Insert one end of the sipper tube into the *Sample Inlet* port (*Portable and On-Line TOC Analyzers*) or side *Inlet* port (*Laboratory TOC Analyzer*) and the other end into a laboratory container filled with clean water.

Chapter 8 TROUBLESHOOTING

3. On the *Maintenance*  screen, select the *Diagnostics* tab.



4. Press **FLUIDICS**. The *Diagnostic — Fluidics Module* dialog box appears.

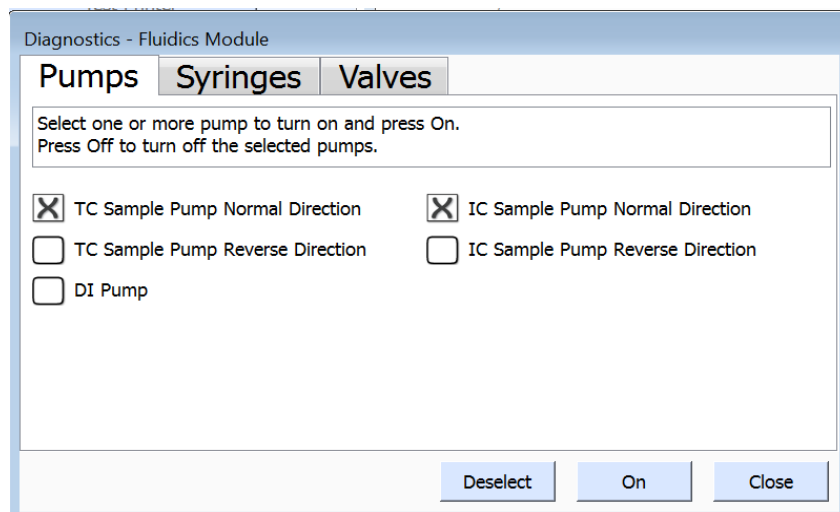

5. Select one or more of the following and press **ON**:
 - *TC Sample Pump Normal Direction*
 - *TC Sample Pump Reverse Direction*
 - *IC Sample Pump Normal Direction*
 - *IC Sample Pump Reverse Direction*
 - *DI Pump*
6. View the pumps to see if they are turning.
7. If the pumps are not turning, contact Technical Support or your local service provider for instructions.
8. Press **DESELECT** and **CLOSE** to stop running the sample pumps.

To check the syringes

1. On the *Maintenance*  screen, select the *Diagnostics* tab.

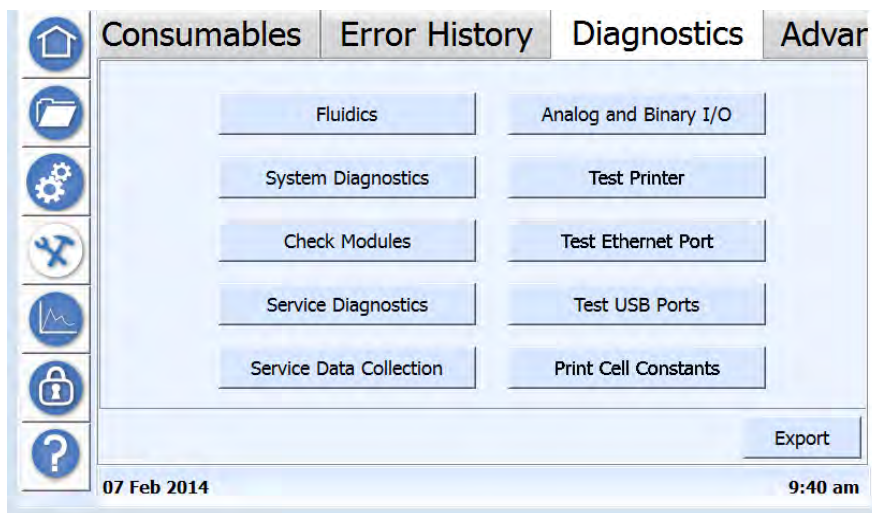

2. Press **FLUIDICS**. The *Diagnostic — Fluidics Module* dialog box appears.

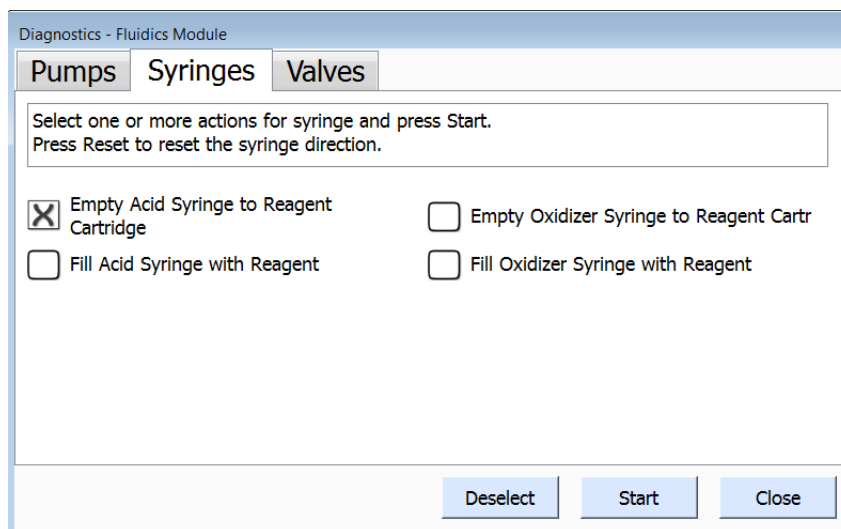

3. Press the *Syringes* tab.
4. Select one or more of the following:
 - *Empty Acid Syringe to Reagent Cartridge*
 - *Fill Acid Syringe with Reagent*
 - *Empty Oxidizer Syringe to Reagent Cartridge*
 - *Fill Oxidizer Syringe with Reagent*
5. Press **START** and view the applicable syringe(s) to verify the action.
6. If the syringes are not filling and/or emptying, contact Technical Support or your local service provider for instructions.

Chapter 8 TROUBLESHOOTING

7. Press **CLOSE**.

To check the valves

1. On the *Maintenance*  screen, select the *Diagnostics* tab.

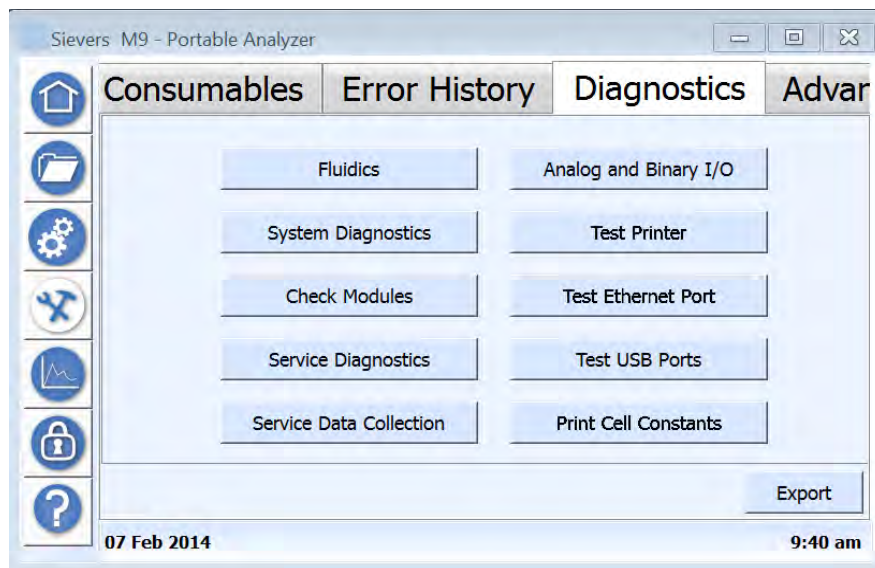

2. Press **FLUIDICS**. The *Diagnostic — Fluidics Module* dialog box appears.

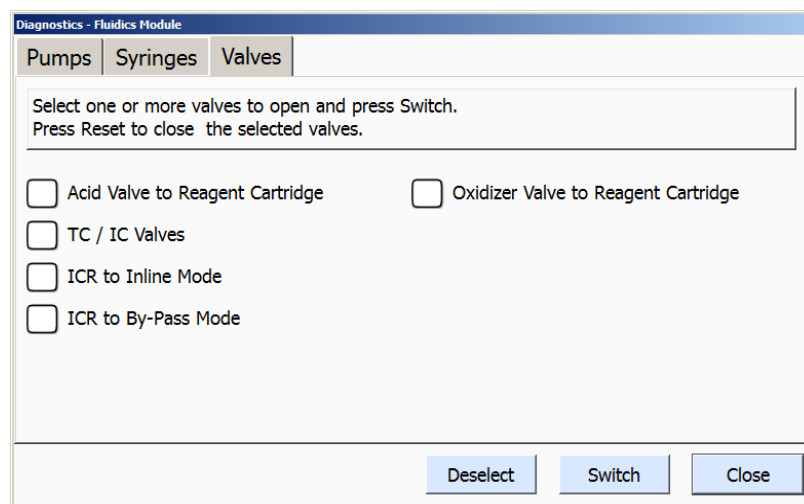

3. Press the *Valves* tab.

4. Select one or more of the following:

- *Add Valve to Reagent Cartridge*
- *TC/IC Valves*

- ICR to Inline Mode
 - ICR to By-Pass Mode
 - Oxidizer Valve to Reagent Cartridge
5. Press **SWITCH** and verify the action.
 6. Press **RESET** to close the selected valve(s).
 7. If the syringes are not opening and/or closing, contact Technical Support or your local service provider for instructions.
 8. Press **CLOSE**.

To check the inlet tubing

Set up a grab sampling from a container in order to confirm that sample is properly being drawn into the Analyzer. Remove the iOS stainless steel fitting from the Analyzer's *Sample Inlet* port (*Portable and On-Line models*). Insert one end of the sipper tube into the *Sample Inlet* port (*all models*) and the other end into a laboratory container filled with clean water.

Introduce a small air bubble into the tubing and track its movement. Remove the tubing from the liquid level in the container for a few seconds and replace the tubing. There should be an air bubble in the tubing. If the bubble moves through the tubing and into the Analyzer, the inlet tubing is not obstructed.

Other troubleshooting techniques for lack of flow include checking whether the sample pump is operating (see ["To check the sample pumps" on page 229](#)), verifying that the in-line filter (on-line sampling) is not clogged, or verifying that the inlet or outlet lines (grab sampling) have not collapsed from over-tightening.

If air is still not drawn into the Analyzer or water is not flowing out of the Analyzer, replace the sample pumps (refer to ["To replace the sample pump heads" on page 202](#)).

To prepare for the backflush

When there is a lack of flow through the Analyzer, a backflush of the sample side or DI side fluidics can clear clogs in the tubing.

1. Stop any analysis and ensure that the power to the Analyzer is off and disconnected from its power source.
2. Set up the Analyzer for grab mode sampling, using a sipper tube and laboratory container. You will use this to observe the backflush flow as a verification that any clogs have been cleared.

Chapter 8 TROUBLESHOOTING

3. Disconnect the waste tubing coming out of the TC/IC Y-connector [Figure 67](#).

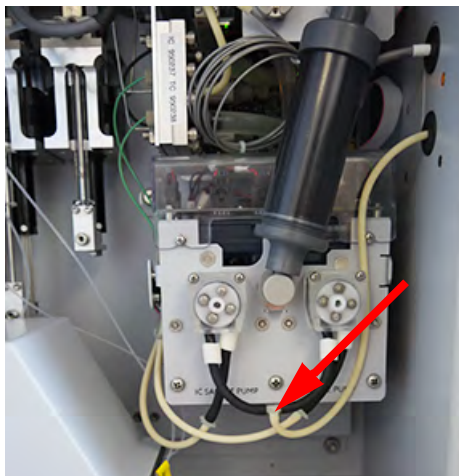
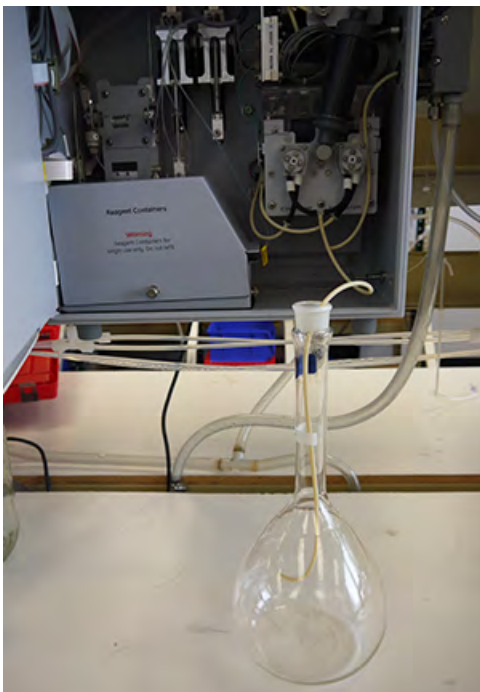

Figure 67: TC/IC Y-Connector

4. Locate the extra tubing from the Analyzer Accessories Kit and connect one end to the Y-connector.
5. Insert the other end into a laboratory container filled with DI water.



6. Power on the Analyzer.

7. On the *Maintenance*  screen, select the *Diagnostics* tab.

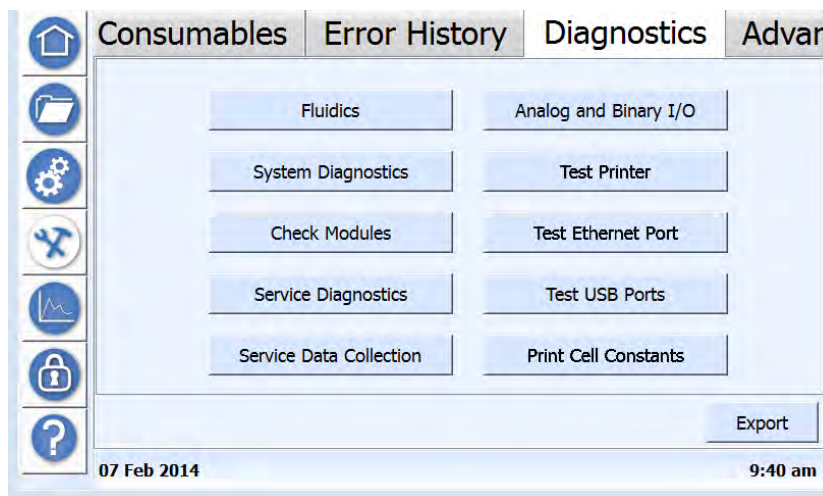

8. Press **FLUIDICS**. The *Diagnostic — Fluidics Module* dialog box appears.

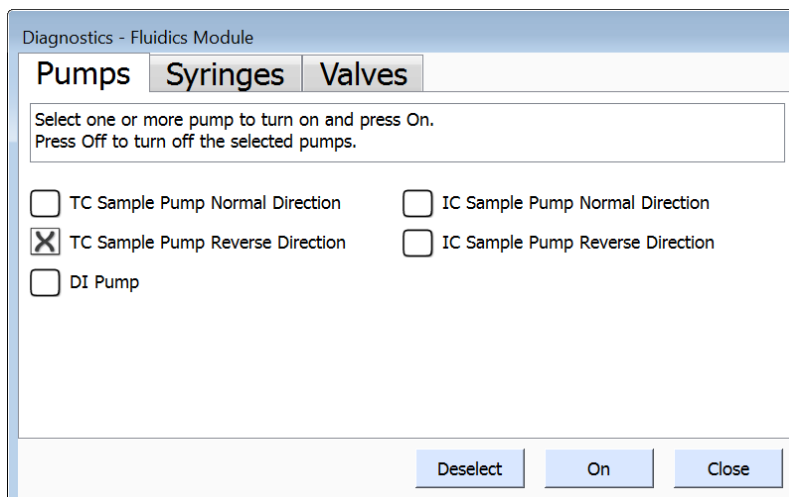

9. Press **DESELECT** to clear all options.

10. Select one of the following depending upon which line has the lack of flow:

- *TC Sample Pump Reverse Direction*
- *IC Sample Pump Reverse Direction*

11. Press **ON** to run the pump in the reverse direction and clear the obstruction.

12. Observe the flow coming out of the inlet into the laboratory container to ensure that a backflush flow has been established and that the clog has been cleared.

13. Press **OFF** to turn off the pump.

14. Disconnect the tubing installed at the Y-connector.

15. Reconnect the waste tubing.

16. If needed, continue to ["To test the DI fluidics side for obstruction."](#)

Chapter 8 TROUBLESHOOTING

To test the DI fluidics side for obstruction

If you were not able to establish flow with the previous procedure, test the DI fluidics side of the Analyzer for an obstruction.

1. Disconnect the top tubing from the solenoid valve ([Figure 68](#)) and observe to see if water drips from the end of the tubing.

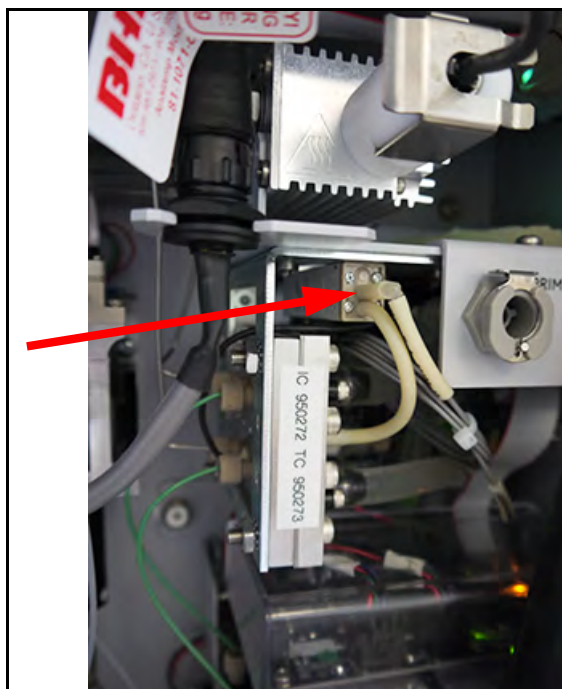

Figure 68: Backflushing the Sample Side

2. If water drips, there is no DI fluidics side obstruction. Reconnect the tubing.
3. If no water dripped from the tubing, turn the DI pump option on and off and observe if the tubing now drips water (*Maintenance* screen > *Diagnostics* tab > **FLUIDICS** button). If there is still no dripping, reconnect the tubing and contact Technical Support or your local service provider for help with resolving the obstruction.

BUBBLES IN REAGENT LINES OR SYRINGES

The presence of bubbles in the lines from the reagent containers to the syringe pumps and from the syringe pumps to the stainless steel cross can cause erratic TOC readings. Shut down and turn off the Analyzer and disconnect the power. Open the Analyzer and inspect the 1/16" Teflon tubing from the syringes. If you detect bubbles in the lines or a large (larger than the head on a pencil eraser) bubble in the syringe, reconnect the power cord, turn on the Analyzer, and perform a syringe flush. For further information, see ["To flush the reagent syringes" on page 211](#).

PH OF WASTE STREAM IS TOO HIGH

If the pH of the waste stream is too basic, erratic readings may be observed. Increase the acid flow rate by 1 $\mu\text{L}/\text{min}$ and determine if this eliminates the problem.

Obtain a strip of pH paper for this next procedure. Start an analysis on Analyzer and with the sample stream flowing, hold the paper in the waste stream.

Compare the color of the paper with the pH color scale on the side of the pH paper container. If the pH is not less than 3, not enough acid is being added to the sample stream.

POSSIBLE HIGH PH CAUSES

Check the following possibilities to determine the root cause.

- *The valve on a CLEAR CARTRIDGE acid cartridge is closed.* — Push in the green button to open the valve.
- *The acid flow rate is too low.* — Set the acid to a higher flow rate on the *Modify Current Method* dialog box (*Home* screen > **SETUP**).
- *The acid reagent cartridge is empty or low and needs to be replaced.* — Perform a visual check of the reagent cartridge, and replace if needed. See [“Replacing the Chemical Reagents” on page 186](#).
- *The acid syringe is defective or not working.* — Contact Technical Support or your local service provider for instructions.

ERRATIC READINGS DUE TO HIGH IC

The Analyzer calculates TOC from the difference between TC and IC and TOC accuracy may be reduced in water samples containing high levels of IC, where the IC is greater than 10 times the TOC value. This is often the case for ground water samples, some municipal water supplies, and permeate from reverse osmosis systems.

To eliminate the problems encountered in TOC measurements of water samples containing high levels of IC, the ICR is installed inside the Analyzer that uses a degasser to remove approximately 95% of the IC is at concentrations up to 25 ppm. The ICR may need servicing. Perform maintenance on the ICR. See [“Replacing ICR Consumables” on page 208](#). For more information on the ICR, contact Technical Support or your local service provider.

NEGATIVE MEASUREMENTS

Many of the previous steps in this chapter will help troubleshoot negative measurements. If the previous steps did not remedy the situation, you may need to perform a TC/IC Cell Conductivity Autozero.

Chapter 8 TROUBLESHOOTING

To manually set the TOC Offset

At extremely low TOC concentrations, very small changes in water system conditions may make it difficult to use the TOC Autozero procedure for the purposes of achieving instrument-to-instrument agreement consistent with the stated analyzer specifications. If the TOC Autozero procedure does not yield acceptable agreement between multiple instruments, use the manual TOC zero offset adjustment to adjust the TOC reading to match a known accurate reference value.

1. On the *Configuration*  screen, select the *System Setup* tab.

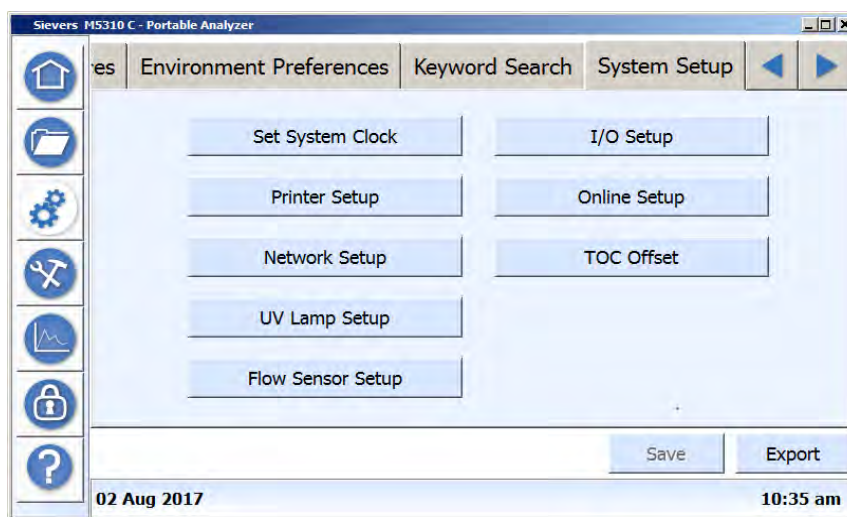

2. Press **TOC OFFSET**. The *TOC Offset* dialog box appears.

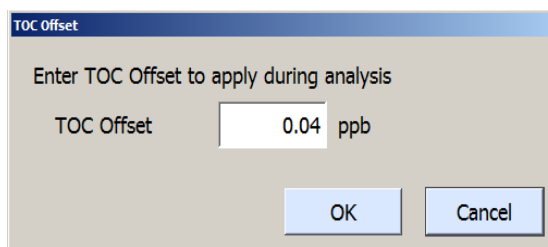

3. Press inside the *TOC Offset* field and use the numeric keypad to enter a ppb value between **-5.00** and **5.00**.
4. Press **OK** to save.

PROBLEMS CHANGING THE PROGRAM LANGUAGE

If you change the program language out of your native language, it is possible that you will not be able to switch back easily since you cannot read the program menus. If this happens, navigate to the original language as described in the following procedure.

To change the program language

1. Select the *Configuration* screen identified by this icon .
2. Select the second tab from the left (this is the *Environment Preferences* tab).



3. Select your language in the drop-down list. Counting from the top down, the first language is *English*, the second *Simplified Chinese*, and the third *Japanese*.
4. A dialog box will appear, press **OK** at the bottom of the dialog box.



5. On the *Configuration* tab, press the first (Save) button at the bottom of the tab.

Chapter 8 TROUBLESHOOTING

- You will now need to shut down the Analyzer and restart for the change to take effect. Press the *Home*  icon to display the *Home* screen.



- Press the *Shut Down* icon. A Shut Down confirmation message appears.

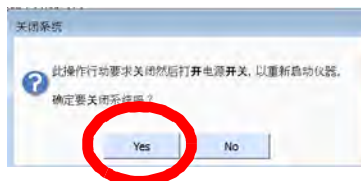

- Press **YES** to confirm and shutdown the Analyzer.
- Restart the Analyzer. The screens will now appear in your language (as selected).

STEP 4: PERFORM ADDITIONAL DIAGNOSTICS

This section includes some additional diagnostic activities that may be helpful when troubleshooting issues.

Disabling the UV Lamp

While troubleshooting, there may be times when you need to have the Analyzer powered on without turning on the UV lamp.

To disable the UV lamp

1. On the *Configuration*  screen, select the *System Setup* tab.

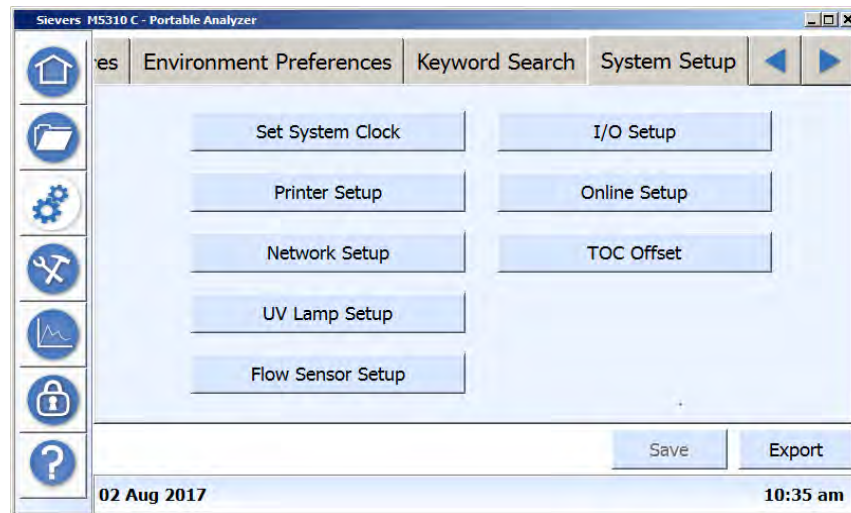

2. Press **UV LAMP** Setup. The UV Lamp Setup dialog box appears.

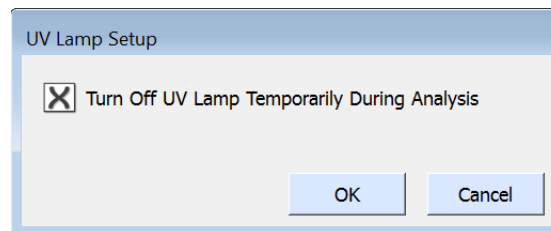

3. Select the *Turn Off UV Lamp Temporarily During Analysis*, and press **OK**.

Using the Diagnostics Tab

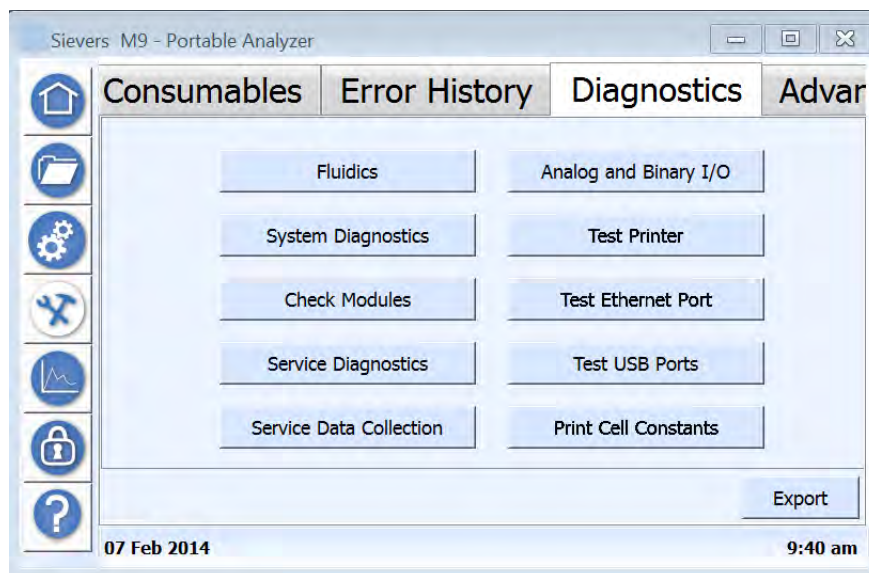

Figure 69: The Diagnostics Tab

This tab includes some additional diagnostic features, including:

- *Fluidics* — Turn the IC and TC sample pumps and DI pump on or off for specific diagnostic activities. For additional information, see [“To check the sample pumps” on page 229](#) and [“To test the DI fluidics side for obstruction” on page 236](#).
- *System Diagnostics* — This tab is used to check the sensors within the Analyzer if there is a failure. Contact Technical Support or your local service provider for guidance on its use.



NOTE: Only use this feature if instructed to by Technical Support. At that time, Technical Support or your local service provider will guide you through troubleshooting processes using these dialog boxes

- *Check Modules* — When working with Technical Support, you may also be guided to use this feature similar to the automatic check the Analyzer performs during start up of the Analyzer. For more information, see [“Reviewing the Self Check Summary” on page 217](#).
- *Service Diagnostics* — Only use this feature if instructed to by Technical Support. At that time, Technical Support will guide you through troubleshooting processes using these dialog boxes.
- *Service Data Collection* — Use this feature if Technical Support guides you through troubleshooting processes of collecting service level data to send them.

- *Analog and Binary I/O (On-Line and Portable TOC Analyzers Only)* — This button is used when installing 4-20 mA output, alarms, and/or binary input connections. See [“Configuring the Data I/O \(Optional\)” on page 82](#).
- *Test Printer* — Press this button to send a test print to the printer. You can also send a test print on the *Printer Setup dialog box* when initially installing the printer. See [“To install a USB printer” on page 70](#).
- *Test Ethernet Port* — Press this button to access the *Ethernet Diagnostics* dialog box. For step-by-step instructions, refer to [“To test the Ethernet connection” on page 243](#).
- *Test USB Ports* — Press this button to access the *USB Diagnostic* dialog box. For step-by-step instructions, refer to [“To test the USB connection” on page 246](#).
- *Print Cell Constants* — Before running certain system protocols (such as a TOC Autozero), print cell constants as directed using this button. A printer must be connected before this button is in an active state. Refer to [“To install a USB printer” on page 70](#), as needed.

To test the Ethernet connection

Use this feature to ensure that the internal wiring and connectors for the Ethernet port are operating correctly.

Warning	
	<p>This procedure involves temporarily installing an Ethernet cable from the Analyzer’s external Ethernet port to an internal Ethernet port and should ONLY be performed by a qualified technician.</p>

1. Shut down and turn off the Analyzer.
2. Make sure to exercise ESD protection and perform one of the following:
 - *On-Line TOC Analyzers* — Open the door to the Analyzer and loosen the captive screws to remove the back door panel. (Refer to [“On-Line Analyzer Views” on page 176](#), as needed.)
 - *Laboratory and Portable TOC Analyzers* — Remove the left panel to access the Analyzer electronics. (Refer to [“Laboratory Analyzer Views” on page 178](#) or [“Portable Analyzer Views” on page 179](#), as needed.)

To gain access to the internal Ethernet port, remove the two top USB cables [Figure 70](#). The Laboratory TOC Analyzer has an additional USB cable that should remain in place.

Chapter 8 TROUBLESHOOTING

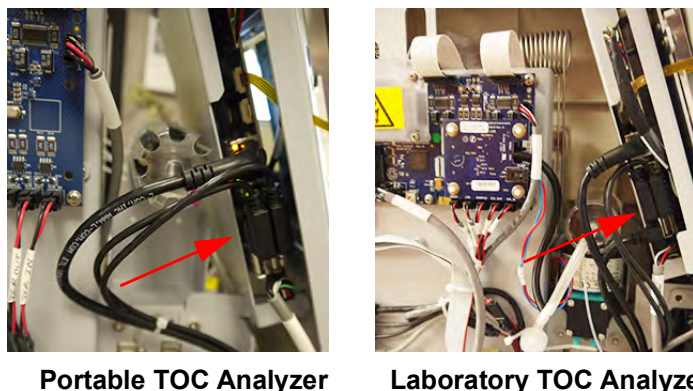

Figure 70: Connecting the Ethernet Cable — Portable and Laboratory Analyzers

3. If you have an *On-Line TOC Analyzer*, connect one end of an Ethernet cable to the lower Ethernet port [Figure 71 \(A\)](#) on the DUC board. Connect the other end of the Ethernet cable to top Ethernet port [Figure 71 \(B\)](#). Proceed to step [5](#).

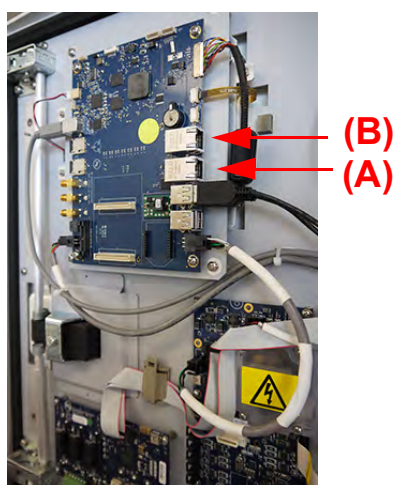
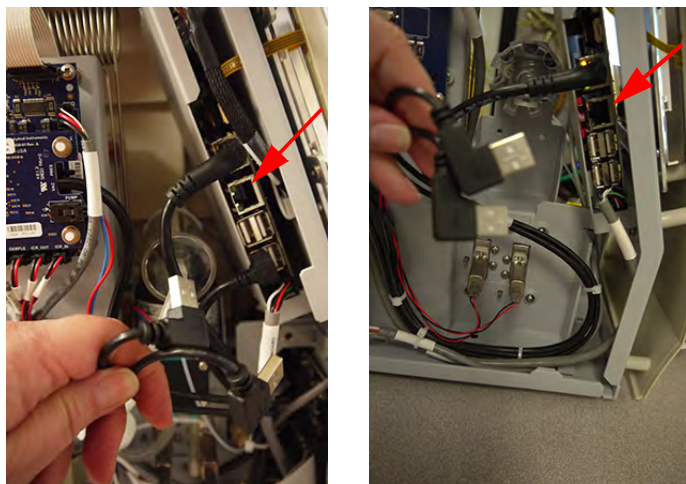

Figure 71: Internal Ethernet Ports — On-Line TOC Analyzer

4. If you have a *Laboratory or Portable TOC Analyzer*, insert one end of the Ethernet cable into the Ethernet port located on the back of the Analyzer.

Insert the other end into the unused Ethernet port [Figure 72](#) inside the Analyzer on the DUC electronics board:



Laboratory TOC Analyzer Portable TOC Analyzer

Figure 72: Ethernet Port on DUC board

5. On the *Maintenance*  screen, select the **Diagnostics** tab.

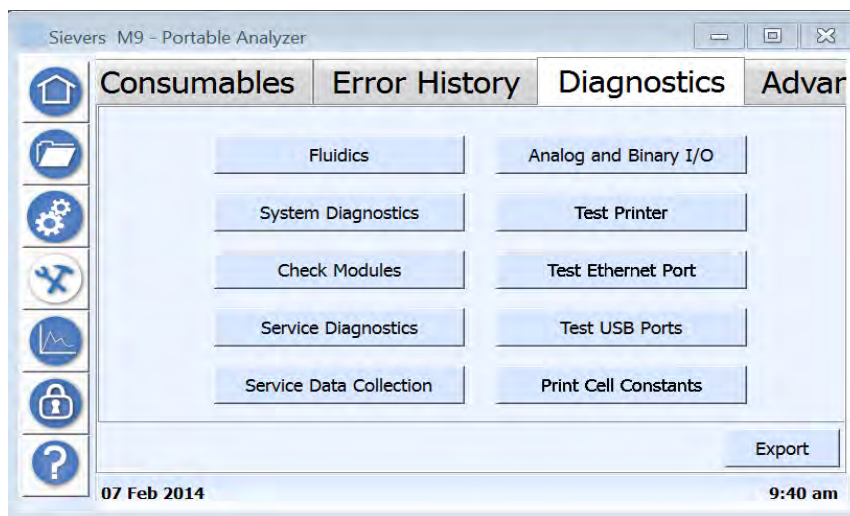

6. Press **TEST ETHERNET PORT**. The *Ethernet Diagnostic* dialog box appears with a message to confirm continuing with configuring the network for the diagnostic.
7. Press **YES**. The Analyzer automatically shuts down and restarts with the new configuration.
8. If the Analyzer is configured to display the *Self Check* diagnostic dialog box, press **CLOSE**.
9. On the *Maintenance*  screen, select the **Diagnostics** tab.

Chapter 8 TROUBLESHOOTING

10. Press **TEST ETHERNET PORT**.

The Ethernet Diagnostic dialog box appears with a message to connect the two Ethernet ports. (This was performed in step 1-3, as for safety reasons the internal Ethernet cable should be connected with the Analyzer powered off.)

11. Press **OK**. The *Ethernet Diagnostic* dialog box appears requesting a confirmation to initiate diagnostics.

12. Press **Start** to confirm. The Analyzer establishes connections and the *Ethernet Diagnostic* dialog box appears with a message that the network diagnostic has completed successfully.

If a message is received indicating that the diagnostic has failed, contact Technical Support or your local service provider.

13. Press **OK** to complete the test. The Analyzer will automatically shut down and restart.

14. Shut down and turn off the Analyzer.

15. Make sure to exercise ESD protection and perform one of the following:

- *On-Line TOC Analyzers* — Remove the Ethernet cable and replace the back door panel. Line up the guide pins with the openings on each corner and tighten the captive screws. Close and latch the Analyzer door.
- *Laboratory and Portable TOC Analyzers* — Remove the Ethernet cable and re-insert the two internal USB cables.

Replace the Analyzer side panel.

16. Power on the Analyzer for use.

To test the USB connection

Use this feature to ensure that the internal wiring and connectors for the USB ports are operating correctly. To perform this test, you will need a USB A-B connection cable. One is provided in the Sievers Autosampler Accessories Kit, or you will need to provide one if you do not have a Sievers Autosampler.

1. On the *Maintenance*  screen, select the *Diagnostics* tab. The *Diagnostics* dialog box appears.

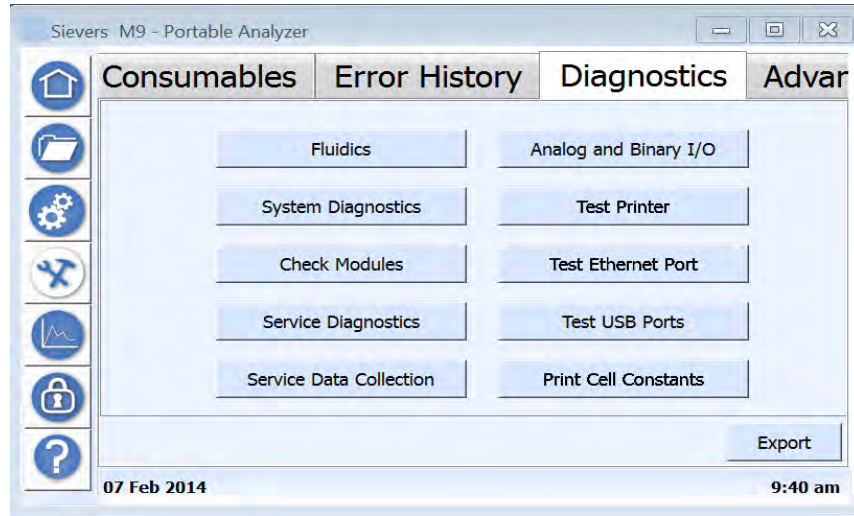

2. Press **TEST USB PORTS**. The *USB Diagnostic* dialog box appears.



3. Insert the **B** connector of the USB A-B cable into the Device USB port on the Analyzer. Insert the **A** connector into one of the Host USB ports.
4. Press **OK**. The *USB Diagnostic* dialog box appears.

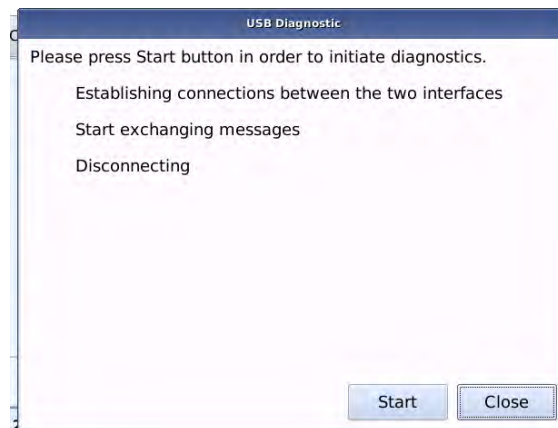

Chapter 8 TROUBLESHOOTING

5. Press **START** to initiate diagnostics. The Analyzer conducts the diagnostics and displays check marks next to each of the activities on *USB Diagnostic* dialog box.

When all three activities show a check mark, the USB test is successful. If one or more the activities fails, contact Technical Support or your local service provider.

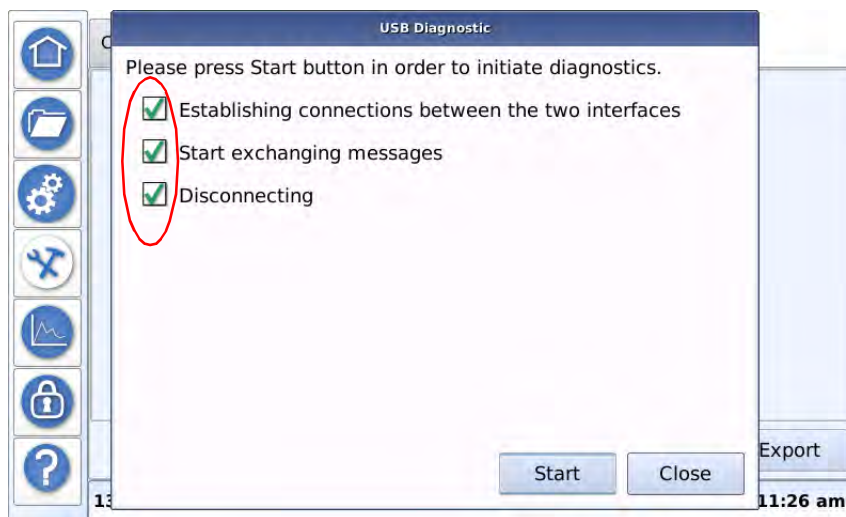

6. Press **CLOSE**.

STEP 5: OBTAIN TECHNICAL SUPPORT

If after completing steps 1 through 4, you need additional assistance troubleshooting, contact Technical Support or your local service provider.

Installation and training by a qualified service technician are also available.

When calling, you will be asked to provide basic Analyzer information from the *Help* screen.

STEP 6: RETURN ANALYZER TO SUEZ

In some instances, after consulting for technical support, it may be necessary to return the Analyzer to the factory for repairs. Only return the Analyzer to SUEZ if Technical Support or your local service provider pre-authorized the return by issuing a Return Authorization (RA) number.

Several precautions must be followed to ensure that the Analyzer is not damaged during shipment. If the original shipping container has not been retained, contact SUEZ Technical Support or your local service provider to order shipping supplies. To avoid

potential shipping damages or damage costs, under no circumstances should the Analyzer be returned in anything other than SUEZ-supplied shipping containers.

To prepare the Analyzer for travel

Prepare the instrument for safe travel before inserting it into the shipping container.

1. Stop any analysis.
2. Disconnect the Analyzer from the sample source, so air will be introduced into the Analyzer sample stream.
3. Empty the reagent syringes. (Navigate to *Maintenance* screen > *Diagnostics* tab. Press **SERVICE DIAGNOSTICS**. A message appears requesting confirmation that water is connected. Ignore this message and press **OK**. Select the *Syringes* tab and the *Empty Acid and Oxidizer Syringes to Reagent Cartridges* option. Press **START**.)
4. When the Analyzer indicates that the process is complete, remove the acid and oxidizer reagent cartridges. Store the reagents for reuse when the Analyzer is returned.
5. On *Portable and Laboratory TOC Analyzers*, remove the reagent holder and pack in the Analyzer Accessories box. For *On-line TOC Analyzers*, ensure that the reagent cover is on and secure. (Again, reagent cartridges should first be removed and **not** included in the shipment.)
6. Navigate to the *Maintenance* screen > *Diagnostics* tab. Press **SERVICE DIAGNOSTICS**. A message appears requesting confirmation that water is connected. Ignore this message and press **OK**. On the *Pumps* tab, toggle both the TC and IC options so that they each marked with an **X** and read “The TC Sample Pump will Turn On” and “The IC Sample Pump will Turn On.” Press **START** to remove any sample remaining in the sample path. Let the TC and IC sample pumps run for approximately 10 minutes. This will ensure that no significant water remains in the waste line.
7. Shut down the Analyzer and turn off the Analyzer. Disconnect the Analyzer from its power source. For *Portable and Laboratory TOC Analyzers*, remove the power cord and pack it into the Accessories Kit.



NOTE: For *On-Line TOC Analyzers*, work with a qualified electrician to disconnect the power source.

8. Drain the DI reservoir (refer to [“To drain excess water from the DI water reservoir” on page 198](#)). In this case, drain all the water from the DI water reservoir.

Chapter 8 TROUBLESHOOTING

9. Remove the resin cartridge and drain. If you requested replacement shipping materials, follow this step. Otherwise, go to step [10](#). Attach the two connectors (provided in the Drain kit sent with the replacement shipping materials) on each end of the resin cartridge. Attach an empty squirt bottle (from Analyzer's Accessories kit) to the bottom of the resin cartridge and hold the resin cartridge over the sink. Squeeze the squirt bottle to blow out as much of the water in the resin cartridge as possible.
10. If you still have your original shipping materials (and don't have a drain kit) or if you cannot find the squirt bottle from the Accessories kit, follow this step. Attach the two resin-cartridge connectors as shown, hold the resin cartridge over the sink, and shake the cartridge to remove as much water as possible.

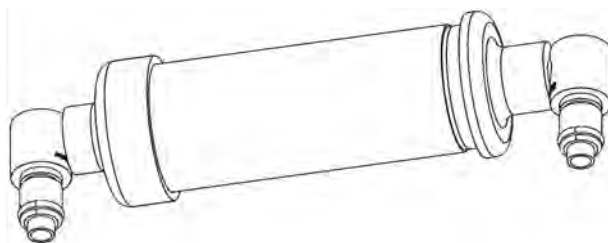

11. Pack the resin cartridge into the Analyzer Accessories Kit.
12. Disconnect the waste tubing from the Analyzer.
13. Remove any printer, alarm, analog output, or computer cables.
14. Locate the original shipping carton and carton inserts. If you need another approved shipping carton and/or carton inserts, contact Technical Support or your local service provider.
15. Using the original carton inserts, insert the Analyzer into the shipping carton.



NOTE: For safety when handling On-Line TOC Analyzers, lay the shipping carton on its side and load the Analyzer. Next, lift the carton upright using a two-person lift.

16. Pack the Analyzer Accessories Kit into the top compartment of the shipping carton.
17. **Insure** the package with the shipping carrier and send to SUEZ per instructions (including RA number) provided by Technical Support or your local service provider.





Also for international shipments, coordinate with Technical Support, or your local service provider, beforehand for information regarding streamlined customs passage.

A











Appendix A: SAFETY WARNINGS

.....









English

WARNINGS	
	<p>Shipping boxes containing an Analyzer may weigh over 40 lb — necessitating a two-person lift technique when handling. Such boxes are labeled with this warning, supporting OSHA standards intended to protect employees from injury.</p> <p>We recommend that our customers use a two-person lift.</p>
	<p>This symbol on the instrument indicates that the user should refer to the manual for operating instructions.</p>
	<p>If this instrument is used in a manner not specified by SUEZ, the safety protection provided by the instrument may be impaired.</p>
	<p>To avoid injury and to ensure accurate analysis results, ensure that the Analyzer door (On-Line TOC Analyzer) is closed and latched or side panels (Laboratory and Portable TOC Analyzers) are on and in place during normal operation.</p>
	<p>(<i>On-Line TOC Analyzer</i>) This symbol indicates the protective earth terminal (ground) for the Analyzer.</p>

Appendix A SAFETY WARNINGS

WARNINGS	
	The Analyzer requires an A/C mains supply of 100-240 volts and requires the correct power cord for safe operation. ONLY use the power cord supplied in the Analyzer's Accessory Kit with the Analyzer, which meets this A/C mains supply requirement.
	For safety reasons and to avoid the possibility of corrupting the database, ALWAYS follow this procedure when shutting down the Analyzer. First stop analysis AND stop the operating system (using the Shut down button in the Analyzer's firmware) BEFORE pressing the Analyzer's power switch to <i>Off</i> or unplugging the power cord,
	Any operation requiring access to the inside of the Analyzer, including installation of maintenance items, could result in injury. To avoid potentially dangerous shock do this. BEFORE opening the Analyzer, stop any analysis and shut down the operating system (using the Shut down  button in the Analyzer's firmware), then turn <i>off</i> power and disconnect from the power supply.
	Electrical conduit and output and alarm connections should be installed by a qualified electrician. ESD protection should also be exercised.
	This is a Class A product. In a domestic environment, this product may cause electromagnetic interference. Take adequate measures to correct the interference.
	Hazardous reagents (ammonium persulfate and phosphoric acid) are used in the Analyzer. Before installing a reagent, read the corresponding Material Safety Data Sheet (MSDS) for proper handling precautions and spill or leak procedures. The MSDS are contained in the pouch located on the outside of the reagent shipping box.
	Installation of reagents and most Analyzer maintenance requires access to the inside of the Analyzer. To avoid potentially dangerous shock do this. BEFORE opening the Analyzer, stop any analysis and shut down the operating system (using the Shut Down  button in the Analyzer's firmware), then turn off power and disconnect from the power supply.
	To avoid exposure to the chemical reagents, wear acid-resistant gloves and safety goggles.

WARNINGS

	Reagent cartridges are for single-use only. Do not refill. Any refilling or reusing of reagent cartridges will void all Analyzer and parts warranties and nullify any performance claims.
	Keep the OPAQUE type reagent cartridge in an upright position before attaching and detaching the reagent supply line to avoid exposure to the chemical reagent. Save the plug to later reinsert it into the nozzle inlet after removing the cartridge from the Analyzer during a cartridge replacement process.
	To protect against accidental exposure to ultra-violet radiation, do not operate the UV lamp outside of its protective housing.
	<i>(On-Line and Portable TOC Analyzers)</i> Water in the iOS System may be hot. Before inserting a vial into the iOS System after operating in On-Line mode, slide the door open and wait 30 seconds to allow sample to completely drain. Inserting a vial before draining can result in hot water spray projecting upward out of the iOS System.
	The iOS System and vial ports contain sharp needles designed to pierce the septa of sample vials. Do not put fingers or inappropriate materials into the iOS System or vial port.
	When servicing parts inside the Analyzer, ensure that power to the Analyzer is OFF, and keep hands clear of the reagent syringe assemblies. The syringes are controlled by moving parts that can pinch skin.
	<i>(Laboratory and Portable TOC Analyzers)</i> For continued protection against fire hazard, replace fuse with same type and rating.
	To avoid potentially dangerous shock, do not touch anything inside the Analyzer while observing the sample pump.
	This procedure involves temporarily installing an Ethernet cable from the back of the instrument into an internal Ethernet port and should only be performed by a qualified technician.

Appendix A SAFETY WARNINGS

WARNINGS							
	<p>This symbol on the instrument indicates that the product does not contain restricted substances included in China RoHS II. Please refer to the following table.</p>						
	<p>M-Series TOC Analyzers</p> <p>Table of Hazardous Substances' Name and Concentration</p>						
	部件名称 Component Name	有害物质 Hazardous Substances' Name					
		铅 (Pb)	汞 (Hg)	镉 (Cd)	六价铬 (Cr(VI))	多溴联苯 (PBB)	多溴二苯醚 (PBDE)
	紫外灯 - UV Lamp	O	X	O	O	O	O
热敏电阻 - Thermistor	X	O	O	O	O	O	
<p>本表格依据SJ/T 11364的规定编制。 This table is prepared according to SJ/T 11364.</p> <p>O: 表示该有害物质在该部件所有均质材料中的含量均在 GB/T 26572规定的限量要求以下 X: 表示该有害物质至少在该部件的某一均质材料中的含量超出 GB/T 26572规定的限量要求</p> <ul style="list-style-type: none"> 此表所列数据为发布时所能获得的最佳信息 <p>O: Indicates that hazardous substance contained in all of the homogeneous materials for this part is below the limit requirement in GB/T 26572. X: Indicates that t hazardous substance contained in at least one of the homogeneous materials used for this part is above the limit requirement in GB/T 26572.</p> <ul style="list-style-type: none"> Data listed in the table represents best information available at the time of publication. <p><i>Please Note: This product contains a UV Lamp (with Hg) which meets the exemption defined in Annex III 4(a) of RoHS Directive 2011/65/EC.</i></p>							

HAZARDOUS MATERIAL DISPOSAL

The following guidelines are provided to aid you in the discarding and the disposal of hazardous substances related to the Sievers M5310 C Analyzer.

 HAZARDOUS MATERIAL DISPOSAL
<p>Hazardous reagents (ammonium persulfate and phosphoric acid) are used in the Analyzer. The waste stream from the instrument is acidic and must be disposed of properly. Consult your federal, state, and local government regulations.</p>
<p>The UV lamp contains mercury and may be considered hazardous material in your local area. Dispose of these items in accordance with federal, state, or local government regulations.</p>



HAZARDOUS MATERIAL DISPOSAL

In the case of any broken or damaged UV lamp, handle the remains in accordance with your organization's toxic waste handling procedure and dispose of them in accordance with federal, state, or local government regulations.



This symbol indicates the European Union Directive 2002/96/EC for waste electrical and electronic equipment (WEEE) requires disposing the Analyzer separately from standard waste.

OPERATIONAL CAUTIONS

To ensure optimal sampling results and to protect the instrument from any damage, review and implement the following Caution statements.

CAUTIONS

Make sure the DI water Reservoir is full, particularly when running samples with high TOC or high salt concentrations. After running high TOC or salt samples, always rinse the Analyzer by running low-TOC DI water through a sample cycle.

Always make sure the sample inlet is open and the DI water reservoir is filled before starting analysis

Operation of the Analyzer without the in-line filter on the sample inlet line will damage the Analyzer and void the warranty. To avoid damaging the Analyzer, install the filter and replace the filter element, as needed.

To avoid damage to the DI water pump, ensure that the DI water reservoir is filled **BEFORE** turning **ON** the Analyzer.
To avoid false TOC readings and possible damage to the Analyzer, always make sure the sample is flowing through the iOS System and the DI water reservoir is filled before starting analysis.

For performance within specifications on ozonated water systems, an Ozone Destruct Kit must be purchased from SUEZ and installed according to instructions.

Appendix A SAFETY WARNINGS

CAUTIONS

When cleaning the Analyzer, always apply liquid to the cloth directly, and do **not** spray liquids directly on the Analyzer.

Do **not** use water or cleaners on the touchscreen, as water can damage or discolor the polarizer. Refer to the next section for recommendations on cleaning the touchscreen.

Wipe away any condensation immediately.

中文 (Chinese)

警告





	<p>装有分析仪的装运箱重达 40 磅以上，需要两个人抬起。装运箱上标有此符合 OSHA 标准的警告，旨在避免员工受伤。</p> <p>建议由两个人抬起分析仪。</p>
	<p>仪器上的此符号表示用户应参阅操作说明手册。</p>
	<p>如果仪器未以 SUEZ 公司规定的方法使用，该仪器所提供的保护功能可能会被减弱。</p>
	<p>为了避免人员受伤，并保证分析结果准确，在分析仪正常运行时，应确保关紧并拴上分析仪的门（适用于在线型 TOC 分析仪），或盖好分析仪的侧面板（适用于实验室型和便携式 TOC 分析仪）。</p>
	<p>（在线型 TOC 分析仪）此符号表示分析仪的保护性接地端（地线）。</p>
	<p>为了安全运行，分析仪要求 100–240 伏的交流电源和正确的电源线。只可使用分析仪附带的电源线，该电源线可满足上述电源要求。</p>
	<p>为安全起见，并避免数据库受损，在关机时，请务必遵循以下操作步骤。首先停止分析，并终止操作系统（用分析仪固件中的关机键），然后再按下电源开关以关闭分析仪，或拔掉电源线。</p>

警告

	任何需要进入分析仪内部的操作，包括安装维护物品，都可能会导致伤害。为避免潜在的危险电击或灼伤，在打开分析仪机壳之前，应停止分析，关闭操作系统（用分析仪固件中的关机键  ），然后再关闭分析仪的电源开关，并拔掉电源线。
	应由合格的电工安装电线导管、输出和警报连接。应采取 ESD 保护措施。
	本产品是 A 级产品。在室内环境中，本产品可能产生电磁干扰，此时用户需要采取适当措施来消除干扰。
	分析仪使用危险试剂（过硫酸铵和磷酸）。在安装试剂之前，应仔细阅读相应的材料安全数据表（MSDS），以便采取正确的处置方法和防漏措施。MSDS 在试剂装运箱外面的袋子里。
	试剂的安装以及其它大多数维护工作都需要在分析仪内部进行操作。为避免潜在的危险电击，应遵循以下步骤：在打开分析仪机壳之前，应先停止分析，关闭操作系统（用分析仪固件中的关机键  ），然后再关闭分析仪的电源开关，并拔掉电源线。
	为了避免人体接触化学试剂，请戴上耐酸手套和护目镜。
	试剂盒是一次性使用的。请勿重新灌注。重新灌注或重复使用试剂盒将使分析仪和部件的保修全部失效，并废止用户的产品性能索赔权。
	在拔出 OPAQUE 类型的试剂盒的塞子之后，在安装和拆下试剂输送管之前，应确保试剂盒保持竖直状态，以免使化学试剂滴落出来，并避免化学试剂溅落到人身上。拔出塞子后请将其保存好，在以后更换试剂盒时可将其塞回原试剂盒的喷嘴入口中。
	为了防止人员意外接触紫外线辐射，请勿在保护罩之外操作紫外灯。
	（在线型和便携式 TOC 分析仪）iOS 系统中的水可能会很热。在在线模式下，在将样瓶插入 iOS 系统之前，应将分析仪的门滑开，等待 30 秒，使样品完全排空。如果在排空样品之前插入样瓶，热水会从 iOS 系统向上喷出。
	iOS 系统和样瓶端口装有用于刺穿样瓶垫片的尖利的针。请勿将手指或不当物体放入 iOS 系统或样瓶端口。



Appendix A SAFETY WARNINGS

警告

	<p>在维修分析仪内部部件时，应确保分析仪已关机，并使双手始终离开试剂注射器组件。注射器由移动部件控制，移动部件可以夹伤人手。</p>																											
	<p>（实验室型和便携式 TOC 分析仪）为了持续防止火灾危险，在更换保险丝时，请使用相同类型和等级的保险丝。</p>																											
	<p>为了避免潜在的危險电击，在观察样品泵时，请勿触摸分析仪内的任何部件。</p>																											
	<p>此过程需要临时安装一条以太网电缆，从分析仪背后连接到内部以太网端口，此操作仅可由合格的技术人员来完成。</p>																											
	<p>仪器上该符号表示该产品确实含有列入中国 RoHS II 限用物质。请参照下表。</p> <p style="text-align: center;">M-Series TOC Analyzers</p> <p style="text-align: center;">Table of Hazardous Substances' Name and Concentration</p> <table border="1" style="width: 100%; border-collapse: collapse;"> <thead> <tr> <th rowspan="2" style="text-align: center;">部件名称 Component Name</th> <th colspan="6" style="text-align: center;">有害物质 Hazardous Substances' Name</th> </tr> <tr> <th style="text-align: center;">铅 (Pb)</th> <th style="text-align: center;">汞 (Hg)</th> <th style="text-align: center;">镉 (Cd)</th> <th style="text-align: center;">六价铬 (Cr(VI))</th> <th style="text-align: center;">多溴联苯 (PBB)</th> <th style="text-align: center;">多溴二苯醚 (PBDE)</th> </tr> </thead> <tbody> <tr> <td style="text-align: center;">紫外灯 - UV Lamp</td> <td style="text-align: center;">0</td> <td style="text-align: center;">X</td> <td style="text-align: center;">0</td> <td style="text-align: center;">0</td> <td style="text-align: center;">0</td> <td style="text-align: center;">0</td> </tr> <tr> <td style="text-align: center;">热敏电阻 - Thermistor</td> <td style="text-align: center;">X</td> <td style="text-align: center;">0</td> <td style="text-align: center;">0</td> <td style="text-align: center;">0</td> <td style="text-align: center;">0</td> <td style="text-align: center;">0</td> </tr> </tbody> </table> <p>本表格依据SJ/T 11364的规定编制。 This table is prepared according to SJ/T 11364.</p> <p>O: 表示该有害物质在该部件所有均质材料中的含量均在 GB/T 26572规定的限量要求以下 X: 表示该有害物质至少在该部件的某一均质材料中的含量超出 GB/T 26572规定的限量要求</p> <ul style="list-style-type: none"> 此表所列数据为发布时所能获得的最佳信息 <p>O: Indicates that hazardous substance contained in all of the homogeneous materials for this part is below the limit requirement in GB/T 26572. X: Indicates that t hazardous substance contained in at least one of the homogeneous materials used for this part is above the limit requirement in GB/T 26572.</p> <ul style="list-style-type: none"> Data listed in the table represents best information available at the time of publication. 	部件名称 Component Name	有害物质 Hazardous Substances' Name						铅 (Pb)	汞 (Hg)	镉 (Cd)	六价铬 (Cr(VI))	多溴联苯 (PBB)	多溴二苯醚 (PBDE)	紫外灯 - UV Lamp	0	X	0	0	0	0	热敏电阻 - Thermistor	X	0	0	0	0	0
部件名称 Component Name	有害物质 Hazardous Substances' Name																											
	铅 (Pb)	汞 (Hg)	镉 (Cd)	六价铬 (Cr(VI))	多溴联苯 (PBB)	多溴二苯醚 (PBDE)																						
紫外灯 - UV Lamp	0	X	0	0	0	0																						
热敏电阻 - Thermistor	X	0	0	0	0	0																						

有害物质处理

以下指导帮助您正确处理和弃置 Sievers M5310 C TOC 分析仪使用的有害物质。

 有害物质处理	
	分析仪使用有害试剂（过硫酸铵和磷酸）。从分析仪中流出的废液是酸性的，必须妥善处理。应查询所在地的国家、州、地方政府的规定。
	紫外灯含有汞，可能在您所在的地区被视为危险材料。处理这些材料时，请遵循国家、州 / 省或地方政府的相关规定。
	如果紫外灯破损，应根据您所在组织机构的有毒废料处理程序以及国家、州 / 省或地方政府的相关规定进行处理。
	此符号表示符合有关废弃电气和电子设备（WEEE）的欧盟指令 2002/96/EC，分析仪应与标准废物分开单独处置。

操作注意事项

为了确保最佳取样结果，并且保护仪器不受损坏，请阅读并执行注意事项。

 注意事项	
	确保去离子水容器已灌满水，尤其是在运行高 TOC 或高盐浓度的样品时。运行高 TOC 或高盐样品之后，请务必运行低 TOC 的去离子水一个样品周期，以冲洗分析仪。
	为了避免 TOC 读数错误，并损坏分析仪，请在开始分析之前，先确保样品入口是打开的，而且去离子水容器已灌满水。
	在操作分析仪时，如果进样管上没有装管内过滤器，将会损坏分析仪，并使仪器的保修失效。为避免损坏分析仪，请安装过滤器，并按需要及时更换滤芯。
	为了避免损坏去离子水泵，在启动分析仪之前，先确保去离子水容器已灌满水。为了避免 TOC 读数错误，并损坏分析仪，请在开始分析之前，先确保样品流经 iOS 系统，而且去离子水容器已灌满水。
	如要按臭氧水系统规格进行操作，必须从 SUEZ 公司订购臭氧破坏组件（Ozone Destruct Kit），并按说明书进行安装。

Appendix A SAFETY WARNINGS



注意事項

在清洁分析仪时，应将清洁液放在抹布上，不可将清洁液直接喷洒在分析仪上。

不可在触摸屏上使用水或清洁剂，水可以使偏振片损坏或褪色。请参阅后面的章节了解触摸屏的清洁方法。











应立即擦去触摸屏上的冷凝水。

日本語 (Japanese)







警告

	<p>分析装置を含む発送用箱は 18 kg (40 lb) を超える場合があり、2 人で取り扱う必要があります。従業員を怪我から守ることを目的とした OSHA 基準に対応しています。</p> <p>この機器を持ち上げるときは、2 人で持ち上げることをお勧めします。</p>
	<p>機器についているこの記号は、ユーザーが操作説明書を参照する必要があることを示します。</p>
	<p>SUEZ が指定した方法で機器を使用しない場合は、機器に設けられた安全保護機能が損なわれる可能性があります。</p>
	<p>怪我をしないように、そして正確な分析結果を得るために、通常運転中には分析装置ドア（オンライン型 TOC 分析装置）を閉じて、留め金が掛けられていること、またはサイド パネル（ラボ型およびポータブル型 TOC 分析装置）が所定の位置に付けられていることを確認してください。</p>
	<p>（オンライン型 TOC 分析装置）このマークは、分析装置の保護アース端子（接地）を示しています。</p>
	<p>分析装置は 100 ~ 240 ボルトの A/C 主電源を必要とし、安全に運転するためには正規の電源コードが必要です。分析装置に付属の電源コードのみを使用してください。このコードは A/C 主電源の要件を満足しています。</p>

警告



	<p>安全のため、そしてデータベースを破損する可能性を避けるため、分析装置の電源を切る時には必ず以下の手順に従ってください。まず分析を停止して、分析装置のホーム (Home) 画面でシステムをシャットダウン (分析装置のファームウェアのシャットダウン (Shut down) ボタンを用いて) してください。その後、分析装置の電源スイッチをオフにして、電源をコンセントから抜いてください。</p>
	<p>保守品目の取り付けを含む分析装置内部にアクセスするどのような操作も、人身傷害につながる可能性があります。潜在的に危険性がある感電を避けるためには、以下の予防措置を講じてください。分析装置を開ける前に、分析を停止し、オペレーティングシステムをシャットダウンし (分析装置のファームウェアにあるシャットダウン (Shut down) ) ボタンを用いて)、電源を切り、電源をコンセントから抜いてください。</p>
	<p>電気コンジット、出力、および警報の接続は、電気技術者の有資格者が行ってください。静電気放電保護具も用いてください。</p>
	<p>これはクラス A の製品です。家庭環境では、本製品が電磁干渉を引き起こす可能性があります。適切な対策を取り、干渉を是正してください。</p>
	<p>分析装置には危険な試薬 (過硫酸アンモニウムやリン酸) が使用されています。試薬を設置する前に、適切な取り扱い上の注意や、こぼれおよび漏れに対する手順について、対応する製品安全データシート (MSDS) をお読みください。MSDS は、試薬輸送箱の外側にある小袋の中に入っています。</p>
	<p>試薬の設置や分析装置の保守には、分析装置の内部にアクセスする必要があります。潜在的に危険な感電を避けるために、次のようにしてください。分析装置を開ける前に、分析を停止し、オペレーティングシステムをシャットダウンし (分析装置のファームウェアにあるシャットダウン (Shut down) ) ボタンを用いて)、電源を切り、その後、電源供給から切り離します。</p>
	<p>化学試薬への暴露をさけるために、耐酸性手袋と安全ゴーグルを着用してください。</p>
	<p>試薬カートリッジは 1 回のみ使用可能です。再充填しないでください。試薬カートリッジを再充填したり再使用すると、分析装置や部品に関わる全ての保証が無効となり、性能に関する損害賠償請求が無効になります。</p>

Appendix A SAFETY WARNINGS

警告	
	ブロー モールド タイプの試薬カートリッジを取り外した後は、試薬供給配管の脱着前にはカートリッジを直立した姿勢で固定し、化学試薬が滴り落ち、化学試薬に暴露することを避けてください。カートリッジ交換処理中、分析装置からカートリッジを取り外した後、ノズル注入口に後で再挿入するために、取り外した後のベントを保管してください。
	紫外線への偶発的な曝露から身を守るために、保護筐体の外で UV ランプを作動させないでください。
	(オンライン型およびポータブル型 TOC 分析装置) iOS システム内の水温が上昇している場合があります。オンライン モードでの運転後にバイアルを iOS システムに挿入する前に、ドアをスライドさせて開け、30 秒間待ち、サンプルが完全に排水されるようにしてください。排水前にバイアルを挿入すると、iOS システムから熱水が上向きに噴出する恐れがあります。
	iOS システムおよびバイアル ポートには、サンプル バイアルのセプタムを穿孔するように設計された鋭利なニードルがあります。指や不適切な物質を iOS システムやバイアル ポートに入れないようにしてください。
	分析装置の内部にある部品を修理する際、分析装置への電源がオフになっていることを確認し、試薬シリンジ アセンブリには触れないようにしてください。シリンジならびその周辺は、可動するため指を挟む危険があります。
	(ラボ型およびポータブル型 TOC 分析装置) 火災の危険から引き続き守るために、同じ型式で定格のフューズと交換してください。
	感電の危険を避けるため、サンプル ポンプを観察している間は分析装置内部のどこにも触れないでください。
	本手順では、分析装置の背面からのイーサネット ケーブルを内部イーサネット ポートに一時的に取り付けることが必要で、有資格の技術者のみが行ってください。

有害物質処分

以下の指針は、SieversM5310 C TOC 分析装置に関連した有害物質を廃棄および処分するうえで支援するために示されています。

 有害物質処分	
	分析装置には危険な試薬（過硫酸アンモニウムやリン酸）が使用されています。機器から出る排水は酸性であるため、正しい方法で廃棄する必要があります。国、都道府県、および地方自治体の政府規制に従ってください。
	UV ランプおよびディスプレイ画面には水銀が含まれており、地域によっては水銀が有害物質に指定されている場合があります。これらの部品は、国や地方自治体の規制に従って処分してください。
	UV ランプが破損、または損傷した場合は、社内の有害廃棄物取扱手順に従って残留物を取り扱い、国、都道府県、または地方自治体の規則に従って処分してください。
	この記号は、廃電気電子機器（WEEE）に関する EU 指令 2002/96/EC に関するものであり、分析装置を適切に処分することが求めていることを示します。

操作上の注意

最適なサンプリング結果を確保するため、そして機器を損傷から守るために、以下の注意に関する記述を見直し、実践してください。

 注意	
	DI 水リザーバーが満杯になっていることを確認してください。特に、TOC または塩濃度が高いサンプルを使用した後は、必ず、低 TOC の脱イオン水を用いて、分析装置の内部流路をリンスしてください。
	誤った TOC 測定値および分析装置に対する損傷の可能性を避けるために、分析を開始する前に、サンプル注入口が開いていて、DI 水リザーバーが満杯になっていることを必ず確認してください。
	サンプル注入口ラインにインライン フィルターを付けずに分析装置を操作した場合は、分析装置に損傷を与え、保証が無効になることがあります。分析装置の損傷を防ぐために、フィルターを取り付け、必要に応じてフィルター エレメントを交換してください。

Appendix A SAFETY WARNINGS



注意

DI 水ポンプの損傷を防ぐため、分析装置の電源を入れる前に、DI 水リザーバーが満杯であることを確認してください。
誤った TOC 測定値や分析装置に損傷を与える可能性を避けるために、分析開始前にサンプルが iOS システムを流れていて、DI 水リザーバーが満杯であることを必ず確認してください。

オゾン処理水システムの仕様範囲内の性能を得るには、オゾン分解キットを SUEZ から購入し、指示に従って取り付ける必要があります。

分析装置を洗浄する場合、必ず液体は布に直接付けてください。そして、分析装置には液体を直接噴霧しないでください。

水が偏光板に損傷を与えたり、変色させる可能性があるため、タッチスクリーンに水またはクリーナーを使用しないでください。タッチスクリーンの洗浄に関する推奨事項については、次のセクションを参照してください。

凝縮物は直ちに拭き取ってください。

Deutsch

WARNUNG



Versandkisten, die den Analysator beinhalten, können über 20 Kg wiegen; dies erfordert beim Hantieren eine Hebertechnik mit zwei Personen. Solche Kisten sind gemäß der OSHA-Standards mit diesem Warnhinweis gekennzeichnet, um Personen vor Verletzungen zu schützen.









Wir empfehlen zum Heben des Analysators ein Zwei-Personen-Hebezeug.









Dieses Symbol auf dem Gerät zeigt an, dass der Benutzer die Betriebsanweisungen in der Anleitung nachschlagen soll.









Wenn dieses Gerät auf eine Weise verwendet wird, die von SUEZ nicht spezifiziert ist, kann die Sicherheit beeinträchtigt werden.

WARNUNG	
	Stellen Sie zur Vermeidung von Verletzungen und zur Gewährleistung genauer Analyseergebnisse sicher, dass bei Normalbetrieb die Türe des Online-TOC-Analysator geschlossen und verriegelt ist oder die Seitenwände der Labor- und tragbaren TOC-Analysatoren an der richtigen Stelle angebracht sind.
	(<i>Online-TOC-Analysator</i>) Dieses Symbol zeigt den Schutzleiter (Erde) des Analysators an.
	Der Analysator benötigt zum sicheren Betrieb eine Wechselspannungsversorgung (AC) von 100-240 V und das richtige Netzkabel. Verwenden Sie nur das mit dem Analysator gelieferte Netzkabel, das die Anforderungen an die AC-Netzversorgung erfüllt.
	Befolgen Sie zum Ausschalten des Analysators aus Sicherheitsgründen und um die Möglichkeit zu vermeiden, die Datenbank zu beschädigen, immer das folgende Verfahren: Beenden Sie zuerst die Analyse UND beenden Sie das Betriebssystem (mit der Beenden-Taste (Shut down) der Analysator-Firmware), BEVOR Sie den Netzschalter des Analysators auf Aus (Off) schalten oder das Netzkabel ziehen.
	Jede Handhabung, einschließlich Installation der Verbrauchsmaterialien, welche den Zugang zum Innern des Analysators erfordert, kann zu Verletzungen führen. Halten Sie folgende Vorsichtsmaßnahmen ein, um einen gefährlichen Stromschlag zu verhindern: Beenden Sie VOR dem Öffnen des Analysators jegliche Analysen, beenden Sie das Betriebssystem (mit der Beenden-Taste  in der Analysator-Firmware). Schalten Sie die Stromversorgung aus und trennen sie das Netzkabel von der Stromversorgung.
	Elektrische Kabelkanäle sowie Ausgangs- und Alarmanschlüsse sind von einem qualifizierten Elektriker zu installieren. Schutz vor elektrostatischer Entladung ist ebenfalls zu beachten.
	Dies ist ein Klasse A-Produkt. In einer häuslichen Umgebung kann dieses Produkt elektromagnetische Störungen verursachen. Ergreifen Sie geeignete Maßnahmen, um diese Störungen zu korrigieren.

Appendix A SAFETY WARNINGS

WARNUNG	
	In dem Analysator werden gefährliche Reagenzien (Ammoniumpersulfat und Phosphorsäure) verwendet. Lesen Sie vor dem Installieren einer Reagenzie das entsprechende Sicherheitsdatenblatt, um geeignete Vorsichtsmaßnahmen beim Umgang mit diesen Reagenzien zu treffen. Die Sicherheitsdatenblätter befinden sich in der Aussentasche an der Reagenzien-Versandkiste.
	Die Installation von Reagenzien (Kartuschen) sowie die meisten Wartungsarbeiten am Analysator erfordern Zugang zum Innern des Analysators. Befolgen Sie zur Vermeidung eines gefährlichen Stromschlags die folgende Prozedur: Beenden Sie VOR dem Öffnen des Analysators jegliche Analysen, beenden Sie das Betriebssystem (mit der Beenden-Taste  in der Analysator-Firmware) und schalten Sie dann die Stromversorgung aus und trennen sie die Stromversorgung.
	Tragen Sie bei der Hantierung mit den chemischen Reagenzien säurebeständige Handschuhe und eine Schutzbrille.
	Reagenzienkartuschen sind nur für den einmaligen Gebrauch bestimmt. Füllen Sie sie NICHT wieder auf. Jegliches Auffüllen oder Wiederverwenden von Reagenzienkartuschen lässt alle Garantien für Analysator und Ersatzteile erlöschen und macht jegliche Haftungsansprüche ungültig.
	Halten Sie nach Entfernen des Stopfens der Reagenzienkartusche vom OPAQUE-Typ die Kartusche aufrecht, bevor Sie die Reagenzien-Versorgungsleitung anbringen oder abnehmen. Diesum zu vermeiden, das Chemikalien heraustropfen und Sie mit dem Reagenz in Kontakt kommen. Bewahren Sie den Stopfen nach dem Abnehmen auf, um diesen später wieder in den Stutzeinlass einzusetzen, wenn die Kartusche im Verlauf eines Kartuschenwechsels aus dem Analysator entfernt wird.
	Betreiben Sie zum Schutz gegen versehentliche Exposition mit UV-Strahlung die UV-Lampe nicht außerhalb ihres Sicherheitsgehäuses.



WARNUNG

	<p><i>(Online und tragbare Analysatoren)</i> Das Wasser im iOS-System kann heiß sein. Warten Sie vor dem Einführen eines Probenfläschchens in das iOS-System nach Betrieb im Online-Modus 30 Sekunden, bis die Probe vollständig abgelaufen ist. Das Einführen eines Probenfläschchens vor dem Ablaufen kann dazu führen, dass heißes Wasser aus dem iOS-System nach oben spritzt.</p>
	<p>Das iOS-System sowie die einzelnen Probeneingänge enthalten scharfe Nadeln, die dafür ausgelegt sind, die Septen der Probenfläschchen zu durchstechen. Halten Sie NICHT die Finger oder andere ungeeignete Materialien in das iOS-System oder den Probeneingang.</p>
	<p>Stellen Sie bei der Wartung im Innern des Analysators sicher, dass die Stromversorgung des Analysator auf Aus (Off) geschaltet ist und kommen Sie mit den Händen nicht in die Nähe der Reagenzienspritzen-Baugruppe. Die Spritzen werden durch bewegliche Teile geregelt, die zu Hautquetschungen führen können.</p>
	<p><i>(Labor- und tragbare TOC-Analysatoren)</i> Tauschen Sie Sicherungen zum Schutz gegen Brandgefahr immer nur gegen Sicherungen des gleichen Typs aus.</p>
	<p>Berühren Sie bei Untersuchung der Probenpumpe keine Teile im Innern des Analysators, um einen u.U. gefährlichen elektrischen Schlag zu vermeiden.</p>
	<p>Diese Verfahren beinhaltet, dass vorübergehend ein Ethernet-Kabel von der Rückseite des Geräts zu einem internen Ethernet-Anschluss verlegt wird, und darf NUR von einem qualifizierten Techniker ausgeführt werden.</p>

Appendix A SAFETY WARNINGS

ENTSORGUNG VON GEFAHRSTOFFEN

Folgende Richtlinien werden als Anleitung zur Entsorgung von Gefahrstoffen bereitgestellt, die im Zusammenhang mit den Sievers M5310 C TOC-Analysatoren auftreten.

 ENTSORGUNG VON GEFAHRSTOFFEN	
	In dem Analysator werden gefährliche Reagenzien (Ammoniumpersulfat und Phosphorsäure) verwendet. Der Abfallstrom aus dem Gerät ist sauer und muss entsprechend den örtlichen Richtlinien entsorgt werden. Beachten Sie Bundes-, Staats- und lokale Bestimmungen.
	Die UV-Lampe und der Anzeigebildschirm enthalten Quecksilber und können an Ihrem Standort als gefährliches Material eingestuft werden. Entsorgen Sie diese Gegenstände gemäß Bundes-, Staats- bzw. lokaler Bestimmungen.
	Behandeln Sie im Fall einer defekten oder beschädigten UV-Lampe die Überreste gemäß der Verfahren zur Behandlung toxischer Abfälle Ihres Unternehmens und entsorgen Sie sie gemäß Bundes-, Staats- bzw. lokaler Bestimmungen.
	Dieses Symbol zeigt an, dass der Analysator gemäß der EU-Richtlinie 2002/96/EC zur Entsorgung von Elektro- und Elektronik-Altgeräten getrennt vom Normalmüll zu entsorgen ist.

VORSICHTSMASSNAHMEN BEIM BETRIEB

Lesen und befolgen Sie zur Gewährleistung optimaler Probenergebnisse und zum Schutz des Geräts vor Beschädigung die folgenden Vorsichtsmaßnahmen.

 VORSICHTSMASSNAHMEN	
	Stellen Sie sicher, dass der DI-Wassertank gefüllt ist, insbesondere bei Probenläufen mit hohem TOC-Gehalt oder hohen Salzkonzentrationen. Spülen Sie den Analysator nach dem Lauf von Proben mit hohem TOC- oder Salzgehalt immer mit DI-Wasser mit niedrigem TOC-Gehalt über einen Probenzyklus.
	Stellen Sie zur Vermeidung falscher TOC-Messwerte und zur Vermeidung möglicher Schäden am Analysator immer sicher, dass der Probeneinlass frei ist und der DI-Wassertank gefüllt ist, bevor Sie eine Analyse starten.



VORSICHTSMASSNAHMEN

Der Betrieb des Analysators ohne Inline-Filter an der Probeneinlassleitung führt zur Beschädigung des Analysators und lässt die Garantie erlöschen. Installieren Sie zur Vermeidung von Schäden am Analysator den Inline-Filter und tauschen Sie das Filterelement nach Bedarf aus.

Stellen Sie zur Vermeidung einer Beschädigung der DI-Wasserpumpe VOR dem Einschalten des Analysators sicher, dass das der DI-Wassertank gefüllt ist. Stellen Sie zur Vermeidung falscher TOC-Messwerte und möglicher Schäden am Analysator immer sicher, dass die Probe durch das iOS-System fließt und der DI-Wassertank gefüllt ist, bevor Sie eine Analyse starten.

Zum Betrieb in ozonhaltigen Wasseranlagen innerhalb der Spezifikationen muss ein Ozonabbau (Ozone Destruct)-Kit von SUEZ erworben und gemäß den Anweisungen installiert werden.

Geben Sie zum Reinigen des Analysators die Flüssigkeit immer auf ein Tuch und sprühen Sie Flüssigkeiten nicht direkt auf den Analysator.

Verwenden Sie für den Touchscreen KEIN Wasser und KEINE Reinigungsmittel, da Wasser den Polarisator beschädigen oder entfärben kann. Im nächsten Abschnitt finden sich Empfehlungen zum Reinigen des Touchscreens.

Wischen Sie etwaige Kondensate sofort ab.

Français









AVERTISSEMENT











Les cartons d'expédition contenant l'analyseur peuvent peser plus de 20 kg — et requièrent un levage à deux personnes pour leur manipulation. Les boîtes portent des étiquettes contenant cet avertissement en conformité avec les normes OSHA conçues pour protéger les employés contre les accidents du travail.







Nous recommandons donc de faire appel à 2 personnes pour lever l'analyseur.

Appendix A SAFETY WARNINGS

AVERTISSEMENT	
	Ce symbole sur les instruments indique que l'utilisateur doit se reporter au manuel pour obtenir des instructions d'utilisation.
	Si cet instrument n'est pas utilisé en conformité avec les recommandations de SUEZ, la protection de la sécurité des personnes peut être compromise.
	Pour éviter les blessures et assurer des résultats d'analyse exacts, vérifier que la porte de l'analyseur (Analyseur COT On-Line) soit fermée et verrouillée et que les panneaux latéraux (Analyseurs COT de laboratoire et portables) soient bien en place pendant l'utilisation habituelle de l'appareil.
	<i>(Analyseur COT On-Line)</i> Ce symbole marque la borne de mise à terre de l'analyseur.
	L'analyseur requiert une alimentation AC secteur de 100-240 volts et un cordon d'alimentation approprié doit être utilisé pour assurer la sécurité des personnes et de l'équipement lors de l'utilisation. Utiliser uniquement le cordon d'alimentation fourni avec l'analyseur, celui-ci satisfait aux exigences d'alimentation CA de l'analyseur.
	Pour des raisons de sécurité et pour éviter le risque de corruption de la base de données, suivre TOUJOURS cette procédure lorsque l'arrêt de l'analyseur. Arrêter d'abord l'analyse ET le système d'exploitation (à l'aide du bouton Shut down (éteindre) du micrologiciel de l'analyseur) AVANT de mettre l'interrupteur de l'analyseur en position Off ou de débrancher le cordon d'alimentation,
	Toute opération qui requiert un accès à l'intérieur de l'analyseur, y compris le remplacement de consommables, risque d'occasionner des blessures. Pour éviter les risques d'électrocution, veuillez suivre les recommandations suivantes. AVANT d'ouvrir l'analyseur, arrêter les analyses en cours, fermer le système d'exploitation (à l'aide du bouton Shut down  (éteindre) du micrologiciel de l'analyseur), arrêter ensuite l'alimentation puis, débrancher le cordon d'alimentation.
	Les câbles électriques d'entrées sorties ainsi que les connexions des alarmes doivent être installés par un électricien qualifié. Des mesures de protection contre les émissions électromagnétiques doivent être prises.

AVERTISSEMENT	
	Cet équipement correspond à la classe A de la FCC. Dans un environnement domestique, cet équipement risque de causer des interférences électromagnétiques. Prendre les mesures appropriées pour corriger ces interférences.
	Des réactifs dangereux (persulfate d'ammonium et acide phosphorique) sont utilisés dans l'analyseur. Avant d'installer un réactif, lire les fiches de données de sécurité (MSDS) correspondantes pour connaître les recommandations de manipulation qui s'imposent et les procédures à suivre en cas de déversement ou de fuite. Les fiches de données de sécurité (MSDS) se trouvent dans un sachet placé sur le carton d'expédition des réactifs.
	L'installation des réactifs nécessite d'accéder à l'intérieur de l'analyseur. Pour éviter tout risque d'électrocution suivez ces instructions. AVANT d'ouvrir l'analyseur, arrêter les analyses en cours et fermer le système d'exploitation (à l'aide du bouton Shut Down  (éteindre) du micrologiciel de l'analyseur), arrêter ensuite l'alimentation puis, débrancher le cordon d'alimentation.
	Pour éviter toute exposition aux produits chimiques, porter des gants résistants à l'acide et des lunettes de sécurité.
	Les cartouches de réactifs sont à usage unique. Ne PAS les remplir. Tout remplissage ou réutilisation des cartouches de réactifs annule la garantie de l'analyseur et invalide les réclamations liées aux performances.
	Après avoir enlevé le bouchon de la cartouche de réactif de type OPAQUE, maintenir la cartouche en position verticale avant de connecter ou de déconnecter le conduit d'alimentation du réactif pour éviter l'écoulement de produits chimiques et éviter le contact avec le réactif. Conserver le bouchon pour refermer le bec d'entrée des cartouches vides retirées de l'analyseur lors du prochain remplacement de cartouches.
	Pour éviter les expositions accidentelles aux rayons ultra-violets, ne pas utiliser la lampe à UV hors de son boîtier de protection.

Appendix A SAFETY WARNINGS

AVERTISSEMENT	
	<p><i>(Analyseurs COT On-Line et portables)</i> L'eau dans le système iOS peut-être chaude. Avant d'introduire un flacon dans le système iOS fonctionnant en mode On-Line, faire glisser le capôt pour ouvrir l'iOS et attendre 30 secondes pour que l'échantillon se vide complètement. L'insertion d'un flacon avant la fin du drainage risque de projeter de l'eau potentiellement chaude vers le haut et hors du système iOS.</p>
	<p>Le système iOS et les ports d'injection des flacons contiennent des aiguilles aiguisées, conçues pour percer la membrane des flacons d'échantillons. Ne pas mettre les doigts ou des matériaux non appropriés dans le système iOS ou dans les ports d'injection des flacons.</p>
	<p>Lors de la maintenance des éléments électriques de l'analyseur, vérifier que l'analyseur soit bien hors tension (OFF), et n'approcher pas les mains de l'assemblage des seringues. Les seringues sont contrôlées par des pièces mobiles qui peuvent pincer la peau.</p>
	<p><i>(Analyseurs COT de laboratoire et portables)</i> Pour une protection continue contre les risques d'incendie, remplacer les fusibles par d'autres du même type et de mêmes caractéristiques.</p>
	<p>Pour éviter tout choc potentiellement dangereux, ne touchez rien à l'intérieur de l'analyseur pendant que vous observez la pompe à échantillon.</p>
	<p>Cette procédure exige d'installer provisoirement un câble Ethernet à partir de l'arrière de l'appareil dans un port Ethernet et ne devrait être effectuée QUE PAR un technicien qualifié.</p>

MISE AU REBUT DES MATÉRIAUX DANGEREUX

Les directives suivantes sont fournies pour vous aider au ramassage et mise au rebut des substances dangereuses concernant les Analyseurs COT Sievers M5310 C.



MISE AU REBUT DES MATÉRIAUX DANGEREUX

Des réactifs dangereux (persulfate d'ammonium et acide phosphorique) sont utilisés dans l'analyseur. Les rejets provenant de l'analyseur sont acides et doivent être éliminés conformément à la législation locale. Consulter les réglementations gouvernementales fédérales, nationales ou locales en vigueur.

La lampe UV et l'écran d'affichage contiennent du mercure et peuvent être considérés comme des matériaux dangereux dans votre région. Éliminer ces pièces conformément aux réglementations gouvernementales fédérales, nationales ou locales en vigueur.

Si la lampe UV est cassée ou endommagée, elle doit être manipulée conformément à la procédure de manipulation des déchets toxiques de votre établissement et éliminée conformément aux réglementations gouvernementales fédérales, nationales ou locales en vigueur.



Ce symbole indique que pour la conformité avec la directive 2002/96/CE de l'Union Européenne concernant les matériels électroniques et électriques mis au rebut, l'analyseur doit être éliminé séparément des déchets standards.

PRÉCAUTIONS DE FONCTIONNEMENT

Afin d'assurer des résultats d'échantillonnage optimaux et de protéger l'instrument de tout endommagement, révissez et mettez en œuvre les mises en garde suivantes.



PRÉCAUTIONS

Vérifier que le réservoir d'eau DI soit plein, notamment lorsque l'analyse d'échantillons à forte teneur en COT ou de sel est réalisée.. Après l'analyse d'un échantillon à concentration élevée en COT ou en sels, toujours rincer l'analyseur en exécutant un cycle d'analyse avec un échantillon contenant de l'eau ultrapure.

Pour réaliser des mesures correctes en COT et le risque d'endommager l'analyseur, toujours s'assurer que l'entrée échantillon soit ouverte et que le réservoir d'eau DI soit rempli avant de lancer l'analyse.

Appendix A SAFETY WARNINGS



PRÉCAUTIONS

L'utilisation de l'analyseur sans le filtre en ligne sur la tubulure d'entrée d'échantillon peut endommager l'analyseur et annule de ce fait la garantie. Pour éviter d'endommager l'analyseur, installer le filtre et remplacer l'élément filtrant quand nécessaire.

Pour éviter d'endommager la pompe à eau DI, s'assurer que le réservoir d'eau DI soit bien rempli AVANT d'allumer l'analyseur.
Pour réaliser mesures de COT correctes et éviter le risque d'endommager l'analyseur, toujours s'assurer que l'échantillon s'écoule bien à travers le système iOS et que le réservoir d'eau DI est rempli avant de démarrer l'analyse.







Pour obtenir les meilleures performances de l'équipement sur des eaux contenant de l'ozone, le kit de destruction de l'ozone (Option) doit être installé conformément aux instructions.

Lors du nettoyage de l'Analyseur, appliquez toujours du liquide au chiffon directement, et NE pulvérisez PAS de liquide directement sur l'Analyseur.









N'utilisez PAS d'eau ou de nettoyant sur l'écran tactile, l'eau peut endommager ou décolorer le polariseur. Consultez la section suivante pour lire les recommandations concernant le nettoyage de l'écran tactile.

Essuyez immédiatement toute condensation.









Italiano

AVVERTENZA	
	<p>Le scatole contenenti l'Analizzatore possono pesare oltre 40 lb (20 kg) e devono essere sollevate da due persone. Le scatole sono etichettate con questa avvertenza, in conformità agli standard OSHA per tutelare i dipendenti da eventuali lesioni.</p> <p>In caso di sollevamento, raccomandiamo di farsi aiutare da un'altra persona.</p>
	<p>Questo simbolo sullo strumento indica che l'utente deve fare riferimento al manuale per le istruzioni d'uso.</p>
	<p>Se lo strumento viene utilizzato secondo modalità non indicate da SUEZ, la protezione di sicurezza fornita dallo strumento potrebbe risultarne compromessa.</p>
	<p>Per evitare lesioni e assicurare l'analisi accurata dei risultati, accertarsi che durante il normale funzionamento lo sportello dell'Analizzatore (Analizzatore di TOC on-line) sia chiuso e bloccato o che i pannelli laterali (Analizzatori di TOC portatili e da laboratorio) siano ben posizionati.</p>
	<p><i>(Analizzatore di TOC on-line)</i> Questo simbolo indica il terminale del conduttore di protezione (terra) dell'Analizzatore.</p>
	<p>L'Analizzatore richiede un'alimentazione principale AC da 100-240 V e il cavo di alimentazione adeguato per garantire un funzionamento in piena sicurezza. Usare esclusivamente il cavo di alimentazione fornito con l'Analizzatore, che soddisfa questi requisiti di alimentazione principale AC.</p>
	<p>Per motivi di sicurezza e per evitare di corrompere il database, quando si arresta l'Analizzatore seguire sempre la seguente procedura. Arrestare l'analisi e il sistema operativo (usando il pulsante di spegnimento nel firmware dell'Analizzatore) prima di impostare l'interruttore dell'Analizzatore su Off o di scollegare il cavo dell'alimentazione.</p>

Appendix A SAFETY WARNINGS

AVVERTENZA	
	Le operazioni che comportano l'accesso ai componenti interni dell'Analizzatore, comprese la parti relative all'installazione e alla manutenzione, possono causare lesioni. Per evitare uno shock elettrico potenzialmente pericoloso, prendere le seguenti precauzioni. Prima di aprire l'Analizzatore, arrestare l'analisi, spegnere il sistema operativo (usando il pulsante di spegnimento  nel firmware dell'Analizzatore) e spegnere e scollegare l'alimentazione.
	La connessione elettrica e i collegamenti di allarme e di output devono essere installati da un elettricista qualificato. Deve essere utilizzata anche la protezione ESD.
	Questo è un prodotto di Classe A. In un ambiente domestico, questo prodotto può causare interferenza elettromagnetica. Prendere le misure adeguate per eliminare l'interferenza.
	Nell'Analizzatore vengono utilizzati reagenti pericolosi (persolfato di ammonio e acido fosforico). Prima di usare un reagente, leggere la relativa Scheda di sicurezza (SDS) per le adeguate precauzioni di manipolazione e le procedure da seguire in caso di fuoriuscita o perdita. Le SDS si trovano nella tasca sul lato esterno della scatola del reagente.
	L'uso dei reagenti e la maggior parte della manutenzione dell'Analizzatore richiede l'accesso al suo interno. Per evitare shock potenzialmente pericolosi procedere come segue. Prima di aprire l'Analizzatore, interrompere l'analisi, spegnere il sistema operativo (usando il pulsante di spegnimento  nel firmware dell'Analizzatore), quindi spegnere e scollegare l'alimentazione.
	Per evitare l'esposizione a reagenti chimici, indossare guanti resistenti agli acidi e occhiali protettivi.
	Le cartucce di reagente sono esclusivamente monouso. Non ricaricarle. L'eventuale ricarica o riutilizzo di cartucce di reagente invaliderebbe tutte le garanzie dei componenti e dell'Analizzatore ed eventuali reclami su prestazioni.



AVVERTENZA

	<p>Dopo la rimozione della presa sulla cartuccia di reagente del tipo OPAQUE, tenere la cartuccia in posizione verticale prima di collegare o scollegare la linea di alimentazione del reagente per evitare il gocciolamento di prodotti chimici e l'esposizione al reagente chimico. Dopo la rimozione, mettere da parte il connettore per reinserirlo in seguito nell'ingresso dell'ugello dopo la rimozione della cartuccia dall'Analizzatore durante il processo di sostituzione della cartuccia.</p>
	<p>Per proteggersi dall'esposizione accidentale alle radiazioni ultraviolette, non azionare la lampada UV fuori dal suo alloggiamento protettivo.</p>
	<p><i>(Analizzatori di TOC on-line e portatili)</i> L'acqua all'interno del sistema iOS potrebbe essere calda. Prima di inserire una fiala all'interno del sistema iOS dopo il funzionamento in modalità on-line, aprire lo sportello e attendere 30 secondi per consentire al campione di defluire completamente. L'inserimento di una fiala prima del prosciugamento può comportare la fuoriuscita di spruzzi d'acqua verso l'alto dal sistema iOS.</p>
	<p>Il sistema iOS e le porte delle fiale contengono aghi taglienti atti a perforare i setti delle fiale di campioni. Non mettere le dita o materiali inadatti all'interno del sistema iOS o della porta della fiala.</p>
	<p>Durante la manutenzione di componenti all'interno dell'Analizzatore, accertarsi che l'alimentazione dell'Analizzatore sia impostata su OFF e tenere le mani lontane dalla siringa del reagente. Le siringhe sono controllate da parti in movimento che possono pizzicare la cute.</p>
	<p><i>(Analizzatori di TOC portatili e da laboratorio)</i> Per una protezione continua contro i pericoli di incendio, sostituire i fusibili con altri dello stesso tipo e potenza.</p>
	<p>Per evitare scosse potenzialmente pericolose, non toccare niente all'interno dell'Analizzatore mentre si osserva la pompa di campionamento.</p>
	<p>Questa procedura comporta l'installazione temporanea di un cavo Ethernet sul retro dello strumento in una porta Ethernet interna. L'installazione deve essere eseguita ESCLUSIVAMENTE da un tecnico qualificato.</p>

Appendix A SAFETY WARNINGS

SMALTIMENTO DI MATERIALI PERICOLOSI

Le seguenti linee guida hanno lo scopo di aiutare l'utente a smaltire sostanze pericolose legate all'uso degli Analizzatori di TOC Sievers M5310 C.

 SMALTIMENTO DI MATERIALI PERICOLOSI	
<p>Nell'Analizzatore vengono utilizzati reagenti pericolosi (persolfato di ammonio e acido fosforico). I rifiuti provenienti dallo strumento sono acidi e devono essere smaltiti adeguatamente. Consultare i regolamenti governativi locali, statali e federali.</p>	
<p>La lampada UV e lo schermo contengono mercurio e possono essere considerati dei materiali pericolosi nella propria area. Smaltire tali oggetti in conformità ai regolamenti governativi locali, statali o federali.</p>	
<p>In caso di lampada UV danneggiata o rotta, gestire i pezzi in conformità alla procedura di smaltimento rifiuti tossici della propria azienda e smaltirli in conformità ai regolamenti locali, statali o federali.</p>	
	<p>Questo simbolo indica che la Direttiva dell'Unione Europea 2002/96/CE sui rifiuti di apparecchiature elettriche ed elettroniche (WEEE) prevede lo smaltimento separato dell'Analizzatore rispetto ai rifiuti standard.</p>



AVVERTENZE PER IL FUNZIONAMENTO

Per garantire risultati di campionamento ottimali e per proteggere lo strumento da danni, leggere e seguire le seguenti avvertenze.









 AVVERTENZE	
<p>Accertarsi che il serbatoio di acqua deionizzata sia pieno, in particolare quando si adoperano campioni con un'elevata concentrazione di TOC o di sale. Dopo aver usato campioni con elevate concentrazioni di TOC o di sale, sciacquare sempre l'Analizzatore con acqua deionizzata a basso contenuto di TOC in un ciclo di campionamento.</p>	
<p>Per evitare letture di TOC errate ed eventuali danni all'Analizzatore, accertarsi sempre che l'alimentazione del campione sia aperta e che il serbatoio di acqua deionizzata sia pieno prima di avviare l'analisi.</p>	

 AVVERTENZE	
<p>L'azionamento dell'Analizzatore senza filtro in linea sulla linea di alimentazione del campione danneggia l'Analizzatore e invalida la garanzia. Per evitare danni all'Analizzatore, installare il filtro e sostituire l'elemento filtrante, secondo necessità.</p>	
<p>Per evitare danni alla pompa di acqua deionizzata, accertarsi che il serbatoio di acqua deionizzata sia pieno prima di accendere l'Analizzatore. Per evitare letture di TOC errate ed eventuali danni all'Analizzatore, accertarsi sempre che il campione stia scorrendo attraverso il sistema iOS e che il serbatoio di acqua deionizzata sia pieno prima di avviare l'analisi.</p>	
<p>Per prestazioni secondo le specifiche su sistemi di acqua ozonizzata, acquistare un kit di distruzione dell'ozono da SUEZ e installarlo seguendo le istruzioni.</p>	
<p>Durante la pulizia dell'analizzatore, applicare sempre il liquido sul panno invece di spruzzarlo direttamente sull'Analizzatore.</p> <p>NON usare acqua o detersivi sul touchscreen. L'acqua potrebbe danneggiare o decolorare il polarizzatore. Fare riferimento alla sezione successiva per raccomandazioni sulla pulizia del touchscreen.</p> <p>Rimuovere immediatamente la condensa.</p>	









Español

ADVERTENCIA	
	<p>La caja de envío que contiene el Analizador puede pesar más de 18 kg (40 lb.). Se necesita de dos personas para levantarlas cuando se las manipule. Las cajas presentan una etiqueta con esta advertencia, conforme a las normas OSHA destinadas a la protección del empleado contra lesiones.</p> <p>Recomendamos que cuando se levante el analizador, lo hagan dos personas.</p>
	<p>Este símbolo en el instrumento indica que el usuario debe consultar el manual para conocer las instrucciones de funcionamiento.</p>





Appendix A SAFETY WARNINGS

ADVERTENCIA	
	Si este instrumento se utiliza de una manera que no sea la especificada por SUEZ, es posible que se vea disminuida la protección de seguridad provista por el instrumento.
	Para evitar lesiones y obtener resultados precisos en los análisis, asegúrese de que la puerta del analizador (Analizador de TOC En Línea) esté cerrada con pestillo o que los paneles laterales (Analizadores de TOC de Laboratorio y Portátil) estén colocados en su sitio durante el funcionamiento normal del aparato.
	<i>(Analizador de TOC En Línea)</i> Este símbolo indica el terminal de protección a tierra (masa) para el Analizador.
	El Analizador requiere una alimentación por red de CA de 100 a 240 voltios, y necesita el cable de energía correcto para un funcionamiento seguro del instrumento. Utilice solamente el cable de energía provisto con el analizador, que cumpla con este requisito de alimentación por red de CA.
	Por razones de seguridad y para evitar la posibilidad de estropear la base de datos, SIEMPRE siga este procedimiento cuando corte el Analizador. Primero pare el análisis Y detenga el sistema operativo (utilizando el botón Cerrar [Shut Down] en el Firmware del Analizador) ANTES de pulsar el interruptor de energía del mismo en la posición Off o desenchufar el cable de energía.
	Toda operación que necesite el acceso al interior del Analizador, incluyéndose la instalación de los elementos de mantenimiento, podría provocar lesiones. Para prevenir posibles descargas eléctricas peligrosas, tome las precauciones siguientes. ANTES de abrir el Analizador, pare el análisis, cierre el sistema operativo (utilizando el botón Cerrar [Shut down ] en el Firmware del Analizador), apague la energía y desconecte de la alimentación por red.
	La instalación de los conductores tipo "conduit", de las salidas y las alarmas debe estar a cargo de un electricista matriculado. Se debe también usar protección electrostática.
	Este es un producto de Clase A. En un entorno residencial, este producto puede que cause interferencia electromagnética. Tome las medidas adecuadas para corregir la interferencia.

ADVERTENCIA



	En el Analizador se utilizan reactivos peligrosos (persulfato de amonio y ácido fosfórico). Antes de instalar un reactivo, lea la hoja de datos de seguridad de materiales (MSDS) para conocer las precauciones de manejo apropiadas y los procedimientos en caso de derrames o fugas. Encontrará las MSDS en la bolsa situada en la parte exterior de la caja de envío con los reactivos.
	Para la instalación de los reactivos y casi todas las operaciones de mantenimiento del analizador es necesario acceder al interior del mismo. Para prevenir posibles descargas eléctricas peligrosas, haga esto. ANTES de abrir el Analizador, pare el análisis y cierre el sistema operativo (utilizando el botón Cerrar [Shut down ] en el Firmware del Analizador), apague la energía y desconecte de la alimentación por red.
	Para evitar la exposición a reactivos químicos, use guantes resistentes a los ácidos y gafas de seguridad.
	Los cartuchos de reactivos se pueden utilizar una sola vez: NO los rellene. Si rellena o vuelve a utilizar los cartuchos de reactivos, se anularán las garantías del Analizador y sus partes respectivamente, y anularán el derecho a realizar cualquier reclamación.
	Después quitar el tapón en el cartucho de reactivo de tipo OPAQUE, mantenga dicho cartucho en posición vertical antes de conectar y desconectar el conducto de suministro de reactivo a fin de evitar que la sustancia química gotee y prevenir así cualquier exposición al reactivo químico. Conserve el tapón después de quitarlo para volver a insertarlo más tarde en la entrada de la boquilla, una vez que retire el cartucho del analizador durante el proceso de reemplazo.
	Para proteger contra la exposición accidental a la radiación de rayos ultravioletas, no ponga a funcionar la lámpara UV fuera de su carcasa de protección.
	<i>(Analizadores de TOC En Línea y Portátil)</i> El agua en el Sistema iOS puede estar caliente. Antes de introducir un vial en el Sistema iOS después de hacer funcionar el instrumento en modo en línea, deslice la puerta para abrirla y espere 30 segundos para que la muestra drene totalmente. Cuando se introduce un vial antes de drenar puede que el agua posiblemente caliente se expulse y salpique hacia arriba del Sistema IOS.

Appendix A SAFETY WARNINGS

ADVERTENCIA	
	El Sistema iOS y los puertos de viales contienen dos agujas filosas diseñadas para perforar los septa de los viales con las muestras. NO ponga los dedos o materiales inadecuados dentro del Sistema iOS o el puerto de viales.
	Cuando se realice el servicio de partes dentro del Analizador, asegúrese de que la energía al Analizador esté desconectada y mantenga las manos alejadas de los conjuntos de jeringa con reactivos. Las jeringas se controlan mediante partes móviles que pueden pellizcar la piel.
	<i>(Analizadores de TOC de laboratorio y portátil)</i> Reemplace el fusible del mismo tipo y potencia para contar con una protección contra incendios.
	Para prevenir una descarga eléctrica potencialmente peligrosa, no toque nada dentro del Analizador mientras observa la bomba de muestras.
	Este procedimiento implica instalar temporalmente un cable de Ethernet desde la parte posterior del instrumento a un puerto Ethernet interno y este procedimiento SÓLO debe estar a cargo de un técnico matriculado.

DESECHO DE MATERIALES PELIGROSOS

Las directrices que se ofrecen a continuación sirven para ayudar a apartar y desechar las sustancias peligrosas relacionadas con los Analizadores de TOC Sievers M5310 C.

 DESECHO DE MATERIALES PELIGROSOS	
<p>En el Analizador se utilizan reactivos peligrosos (persulfato de amonio y ácido fosfórico). El flujo de drenaje del instrumento es ácido y se debe desechar correctamente. Consulte la normativa del gobierno federal, estatal y local.</p>	
<p>La lámpara UV y la pantalla contienen mercurio y puede considerarse material peligroso en su área local. Deseche estos elementos de conformidad con la normativa del gobierno federal, estatal o local.</p>	
<p>Si la lámpara UV se rompe o deteriora, los restos de la misma deben manejarse de conformidad con el procedimiento de manejo de residuos tóxicos de su compañía y desecharse conforme a la normativa del gobierno federal, estatal o local.</p>	
	<p>Este símbolo indica que para cumplir con la Directriz de la Unión Europea 96/2002/CE relacionada con el desecho de equipos eléctricos y electrónicos (WEEE), el Analizador deberá desecharse por separado de los residuos comunes.</p>

PRECAUCIONES OPERATIVAS



Para asegurar resultados óptimos en la toma de muestras y proteger el instrumento de todo daño, revise y ponga en práctica los siguientes enunciados relacionados con las Precauciones.









 PRECAUCIONES	
<p>Asegúrese de que el reservorio de agua DI (pizeta) esté lleno, en especial cuando se analizan muestras con TOC elevado o altas concentraciones de sal. Después de analizar muestras con TOC elevado o alto contenido de sal, siempre enjuague el Analizador haciendo correr agua DI de bajo TOC por el ciclo de muestra.</p>	
<p>Para evitar lecturas falsas de TOC y posible daño en el Analizador, cerciórese siempre de que la entrada de muestra esté abierta y que el reservorio de agua DI (pizeta) esté lleno antes de comenzar con el análisis.</p>	

Appendix A SAFETY WARNINGS









 PRECAUCIONES	
<p>El funcionamiento del Analizador sin el filtro en línea en el conducto de entrada de muestra dañará el Analizador y anulará la garantía. Para evitar los daños al Analizador, instale el filtro y reemplace el elemento filtrante según sea necesario.</p>	
<p>Para prevenir daños a la bomba de agua DI, asegúrese de que el reservorio de agua DI (pizeta) esté lleno ANTES de encender el Analizador. Para evitar lecturas falsas de TOC y posible daño en el Analizador, cerciórese siempre de que la muestra fluya por el Sistema iOS y que el reservorio de agua DI (pizeta) esté lleno antes de comenzar con el análisis.</p>	
<p>Para lograr un rendimiento que cumpla con las especificaciones en los sistemas de agua ozonizada, se debe adquirir un Juego de Destrucción de Ozono en SUEZ e instalarlo de acuerdo con las instrucciones.</p>	
<p>Cuando se limpie el Analizador, siempre ponga el líquido directamente en el paño y NO pulverice líquidos directamente sobre el Analizador.</p> <p>NO utilice agua ni limpiadores sobre la pantalla táctil, puesto que el agua puede deteriorar o decolorar el polarizador. Consulte con la sección siguiente para conocer las recomendaciones sobre la limpieza de la pantalla táctil.</p> <p>Seque toda condensación de inmediato.</p>	





Português

AVISO	
	<p>As embalagens de remessa do analisador podem pesar mais de 18 kg; serão necessárias duas pessoas para levantá-la quando forem manuseadas. Essas embalagens apresentam etiquetas com esse aviso, para estarem de acordo com as normas OSHA que protegem funcionários para que não se machuquem.</p> <p>Recomendamos que duas pessoas levanten o instrumento.</p>
	<p>Este símbolo no instrumento indica que o usuário deve consultar o manual para obter instruções de operação.</p>

AVISO	
	Se este instrumento for usado de forma não especificada pela SUEZ, a proteção de segurança fornecida pelo instrumento poderá ser prejudicada.
	Para evitar ferimentos e para obter resultados de análise precisos, garanta que a porta do analisador (Analisador de TOC em linha) esteja fechada ou que os painéis laterais (Analisadores de TOC portáteis e de laboratório) estejam acionados e posicionados durante a operação normal.
	<i>(Analisador de TOC em linha)</i> Este símbolo indica o terminal protetor de aterramento (terra) do analisador.
	O analisador requer uma fonte de alimentação C/A de 100-240 Volts e requer o cabo de energia correto para operar com segurança. Use apenas o cabo de energia fornecido com o analisador, pois este atende às exigências de fonte de alimentação C/A.
	Por razões de segurança e para evitar a possibilidade de corromper o banco de dados, siga SEMPRE este procedimento quando desligar o analisador: Primeiramente, interrompa a análise E pare o sistema operacional, para isso, use o botão Shut down (Parar sistema) no firmware do analisador, ANTES de posicionar o interruptor do analisador em OFF ou desconectar o cabo de energia.
	Qualquer operação que exija acesso ao interior do analisador, entre elas a instalação de itens de manutenção, pode causar ferimentos. Para evitar descarga elétrica potencialmente perigosa, tome as seguintes precauções. ANTES de abrir o analisador, interrompa a análise, feche o sistema operacional (use o botão Shut down  (Parar sistema) no firmware do analisador), desligue o aparelho e o desconecte da fonte de energia.
	As conexões de conduíte elétrico, de saída e de alarme devem ser feitas por um electricista qualificado. Além disso, proteção contra descarga eletrostática deve ser usada.
	Este é um produto Classe A. Em ambiente doméstico, o produto pode causar interferência eletromagnética. Tome as medidas adequadas para corrigir o problema.

Appendix A SAFETY WARNINGS

AVISO	
	Reagentes perigosos (persulfato de amônio e ácido fosfórico) são usados no analisador. Antes de instalar um reagente, leia a sua respectiva Ficha Técnicas de Segurança de Materiais (MSDS) para conhecer as precauções de manipulação apropriadas e os procedimentos no caso de respingos ou vazamentos. As MSDSs se encontram na bolsa do exterior da caixa de transporte do reagente.
	A instalação dos reagentes e a maioria dos processos de manutenção do analisador exigem o acesso ao interior do dispositivo. Para evitar descarga elétrica potencialmente perigosa, siga os procedimentos a seguir. ANTES de abrir o analisador, interrompa a análise, feche o sistema operacional (use o botão Shut Down  (Parar sistema) no firmware do analisador), desligue o aparelho e o desconecte da fonte de energia.
	Para evitar a exposição aos reagentes químicos, use luvas resistentes a ácidos e óculos de proteção.
	Os cartuchos dos reagentes devem ser usados uma única vez. NÃO os reabasteça. Reutilizar ou reabastecer os cartuchos dos reagentes cancelará todas as garantias do analisador e das suas peças e invalidará qualquer reclamação contra o seu desempenho.
	Depois de remover o plugue do cartucho do reagente do tipo OPAQUE, mantenha o cartucho na posição horizontal antes de conectar e desconectar a linha de abastecimento do reagente, para evitar o gotejamento e a exposição ao reagente químico. Guarde o plugue depois de removê-lo para usá-lo posteriormente na entrada do bocal quando remover o cartucho do analisador no processo de sua substituição.
	Para se proteger da exposição acidental à radiação ultravioleta, não opere a lâmpada UV fora de sua caixa de proteção.
	<i>(Analisadores de TOC em linha e portáteis)</i> A água no sistema iOS pode estar quente. Antes de introduzir um frasco no sistema iOS, depois de operar no modo em linha, abra a porta e espere 30 segundos para que a amostra drene completamente. Introduzir um frasco antes da drenagem pode causar a pulverização de água quente lançada do sistema iOS.

AVISO	
	O sistema iOS e as portas de frascos contêm agulhas afiadas projetadas para perfurar as membranas dos frascos de amostra. NÃO coloque os dedos ou materiais impróprios no sistema IOS ou na porta de frasco.
	Quando fizer a manutenção de peças dentro do analisador, garanta que a energia do analisador esteja desligada e afaste as mãos dos conjuntos de seringas de reagentes. As seringas são controladas por peças que se movem e podem beliscar.
	<i>(Analisadores de TOC portáteis e de laboratório)</i> Para ter proteção constante contra risco de incêndios, substitua o fusível pelo mesmo tipo e categoria.
	Para evitar um choque possivelmente perigoso, não toque em nada dentro do analisador quando examinar a bomba de amostras.
	O procedimento exige a instalação temporária de um cabo Ethernet da parte de trás do instrumento a uma porta Ethernet interna, e a mesma DEVE ser realizada por um técnico qualificado.

DESCARTE DE MATERIAIS PERIGOSOS

As seguintes diretrizes são fornecidas para ajudar a eliminar e descartar substâncias perigosas relacionadas aos Analisadores de TOC Sievers M5310 C.

 DESCARTE DE MATERIAIS PERIGOSOS
Reagentes perigosos (persulfato de amônio e ácido fosfórico) são usados no analisador. O fluxo de resíduos do instrumento é acidífero e deve ser eliminado de forma adequada. Consulte as regulamentações dos governos federal, estadual ou local.
A lâmpada UV e a tela contêm mercúrio e podem ser consideradas material perigoso na sua localidade. Descarte esses itens de acordo com as regulamentações dos governos federal, estadual ou local.

Appendix A SAFETY WARNINGS



DESCARTE DE MATERIAIS PERIGOSOS

Se a lâmpada UV quebrar ou for danificada, manuseie os vestígios de acordo com o procedimento de manipulação de resíduos tóxicos da organização e o descarte de acordo com as regulamentações do governo federal, estadual ou local.



Este símbolo indica que a Diretiva da União Europeia 2002/96/EC para resíduos de equipamentos elétricos e eletrônicos (REEE) requer que o analisador seja descartado separadamente do lixo comum.

CUIDADOS OPERACIONAIS



CUIDADOS

Certifique-se de que o reservatório de água deionizada está cheio, especialmente, quando analisar amostras com TOC elevado ou concentrações altas de sal. Depois de analisar amostras com teor de sal ou TOC elevado, enxágue sempre o analisador operando um ciclo de amostra com água deionizada com TOC baixo.

Para evitar leituras de TOC falsas e possíveis danos ao analisador, verifique sempre se a entrada de amostras está aberta e se o reservatório de água deionizada está cheio antes de começar a análise.

A operação do analisador sem filtro em linha na entrada de amostras danificará o analisador e cancelará a garantia. Para evitar danificar o analisador, instale o filtro e substitua o elemento de filtro quando necessário.

Para evitar danos à bomba de água deionizada, verifique se o reservatório de água deionizada está cheio ANTES de ligar o analisador. Para evitar leituras de TOC falsas e possíveis danos ao analisador, verifique sempre se a amostra flui através do sistema iOS e se o reservatório de água deionizada está cheio antes de começar a análise.

Para operar dentro das especificações para sistemas de água ozonizada, um kit Ozone Destruct deve ser adquirido da SUEZ e instalado de acordo com as instruções.



CUIDADOS

Quando limpar o analisador, aplique sempre o líquido no pano e NÃO pulverize líquidos diretamente no analisador.

NÃO use água ou líquidos de limpeza na tela touchscreen, pois a água pode danificar ou descolorir o polarizador. Consulte a seção a seguir para obter recomendações para limpar a tela touchscreen.

Limpe qualquer condensação imediatamente.

Appendix A SAFETY WARNINGS

THIS PAGE IS INTENTIONALLY LEFT BLANK.

B

Appendix B: Protocol Worksheets



Documenting Calibration Results

The following worksheets are provided for use in recording calibration and verification protocol results.

THIS PAGE IS INTENTIONALLY LEFT BLANK.



Single-Point Calibration for Grab/On-Line Worksheet

Company Name	
Analyzer Serial Number	Firmware Version
Analyzer Type	Analyzer Location
Concentration of Standard	Standards Lot # / Exp. Date

SINGLE-POINT CALIBRATION	
TOC Autozero Performed (Yes/No)?	
Reagent/Rinse Flush Performed (Yes/No)?	
Pass/Fail Criteria: The RSD of the TOC measurement of the TOC standard and the IC measurement of the IC standard is $\leq 3\%$ The % Difference for the IC standard is $\pm 10\%$ The attached data will indicate a <i>Passed</i> or <i>Failed</i> condition.	
Calibration Results: <input type="checkbox"/> <i>Passed</i> <input type="checkbox"/> <i>Failed</i>	
Calibration Action: <input type="checkbox"/> <i>Applied</i> <input type="checkbox"/> <i>Rejected</i>	

Performed by:	Date:
Reviewed by:	Date:
Verified by:	Date:
Include Results Data on Additional Pages (printed directly from the Analyzer or exported .csv file)	

THIS PAGE IS INTENTIONALLY LEFT BLANK.



Multi-Point Calibration for Grab/On-Line Worksheet

Company Name	
Analyzer Serial Number	Firmware Version
Analyzer Type	Analyzer Location
Concentration of Standards	Standards Lot # / Exp. Date

MULTI-POINT CALIBRATION

TOC Autozero Performed (Yes/No)?

Reagent/Rinse Flush Performed (Yes/No)?

Pass/Fail Criteria:

The RSD of the TOC measurement of the 250 ppb TOC standard is ≤5%

The RSD of the TOC measurement of TOC standards >250 ppb and the IC measurement of the IC standard is ≤3%

The % Difference for the IC standard is ±10%

R² value ≥ 0.993

The attached data will indicate a *Passed* or *Failed* condition.

Calibration Results: *Passed* *Failed*

Calibration Action: *Applied* *Rejected*

Performed by:	Date:
Reviewed by:	Date:
Verified by:	Date:

Include Results Data on Additional Pages (printed directly from the Analyzer or exported .csv file)

THIS PAGE IS INTENTIONALLY LEFT BLANK.



Single-Point Verification for Grab/On-Line Worksheet

Company Name	
Analyzer Serial Number	Firmware Version
Analyzer Type	Analyzer Location
Concentration of Standard	Standards Lot # / Exp. Date

SINGLE-POINT VERIFICATION

(For 1, 2, 5, 10, 25, or 50 ppm ONLY) Reagent Flush Performed (Yes/No)?

Pass/Fail Criteria:

TOC and IC Percent Difference $\pm 7\%$ (≤ 1 ppm Std)

TOC and IC Percent Difference $\pm 5\%$ (> 1 ppm Std)

The RSD of the TOC measurement of the TOC standard and the IC measurement of the IC standard is $\leq 3\%$

The attached data will indicate a *Passed* or *Failed* condition.

Verification Results: *Passed* *Failed*

Performed by:	Date:
Reviewed by:	Date:
Verified by:	Date:

Include Results Data on Additional Pages (printed directly from the Analyzer or exported .csv file)

THIS PAGE IS INTENTIONALLY LEFT BLANK.

Autoreagent Verification for Grab/On-Line Worksheet

Company Name	
Analyzer Serial Number	Firmware Version
Analyzer Type	Analyzer Location
Concentration of Standard	Standards Lot # / Exp. Date

AUTOREAGENT VERIFICATION
Reagent Rinse/Flush Performed (Yes/No)?

Pass/Fail Criteria: 10 ppm TOC Average within $\pm 5\%$ of 10 ppm and 25 ppm TOC Average within $\pm 5\%$ of 25 ppm The RSD of the TOC measurements is $\leq 5\%$ The attached data will indicate a <i>Passed</i> or <i>Failed</i> condition.
Verification Results: <input type="checkbox"/> <i>Passed</i> <input type="checkbox"/> <i>Failed</i>

Performed by:	Date:
Reviewed by:	Date:
Verified by:	Date:
Include Results Data on Additional Pages (printed directly from the Analyzer or exported .csv file)	

THIS PAGE IS INTENTIONALLY LEFT BLANK.



Appendix C: Working with Modbus

AN INTRODUCTION TO MODBUS

Modbus is an industrial communications protocol that operates over Ethernet on most Sievers TOC instruments. Communications require third-party data acquisition software or a SCADA (supervisory control and data acquisition) system with Modbus TCP/IP support. Modbus communications support the collection of real-time instrument data and status information. The instrument may also be started or stopped remotely and warnings and errors may be reviewed and cleared remotely via Modbus.

Although Modbus protocols vary, generally a Modbus network has one client and one or more servers. The client communicates to each of these servers identified with a unique address or unit number. Packets including these addresses are sent by the client to the servers. If the address is recognized, the server must respond within a certain amount of time.

Modbus is often read and written as registers, which are most often 16-bit pieces of data that include 8-bit device addresses or unit numbers of the servers. These registers can be signed or unsigned. Most often, the register is either a signed or unsigned 16-bit integer. If a 32-bit integer or floating point is required, these values are actually read as a pair of registers. The most commonly used register is called a Holding Register, and these can be read or written. The other possible type is Input Register, which is read-only.

For additional information on Modbus visit <http://www.modbus.org>.

Implementing Modbus Communications on the Analyzer

This is a basic overview of implementing Modbus TCP/IP on an M-Series Analyzer. In addition to configuring the TOC Analyzer, third-party SCADA or data acquisition software (provided by others) will also need to be programmed to communicate with the Analyzer.

Connect the TOC unit via Ethernet and verify that you can see the IP address of the instrument on the network. A Modbus map of the M-Series Analyzer registers and addresses is included in this appendix ([“Modbus Map” on page 303](#)). With the Analyzer running, attempt to read one input register (as described in this appendix). Lastly, attempt to read both TOC registers and set the SCADA system to combine these values and compare this output to the Analyzer display.



NOTE: For issues are encountered during configuration, SUEZ suggests first requesting technical support from the SCADA software supplier, as there is often a simple software related solution. If this is unsuccessful, please contact Technical Support or your local service provider. We are happy to help clarify any questions or technical issues related to our Modbus implementation.

To verify the Modbus connection

Before beginning the instructions, refer to [“Configuring the Network Connection” on page 126](#) to set up the network connection.

After connecting and configuring the Analyzer online via Ethernet, verify that you can see the MAC and IP address of the instrument on the network.

1. With the Analyzer running, attempt to read one input register. For TOC data the SCADA system will be reading the Modbus input registers at memory addresses 3300, 3301, and 3302. The function for these memory addresses should be *04 Read Input Registers*.



NOTE: Some software packages may refer to this function differently, for instance “3x_bit” or similar.

2. Verify that the TOC data is made up of the first two input registers (two 16-bit unsigned registers) at memory address 3300 and 3301.



NOTE: Some software packages may need the memory address formatted as 3301 or 330001, each referring to the first 16-bit register at memory location 3300.

3. The two 16-bit registers noted above referenced in the previous step need to be combined to create one 32-bit TOC value. This is necessary as Modbus only supports 16-bit registers. Your SCADA software will have an option for combining these values.

The input register at memory address 3302 can be read to display the TOC units. Values are 1=pppt, 2=ppb, 3=ppm. This is also a 16-bit value.



4. To read other values, refer to the Modbus register table in this appendix for the correct memory addresses.
5. Set the SCADA system to combine these values and compare this output to the Analyzer display shown on the Analyzer's *Configuration* screen.

To clear warnings and errors using Modbus

1. Write a 1 to the write coil at memory address 2011 to clear all warnings and errors.
2. The write coil at address 2011 resets to 0 after it clears the warnings and errors.



NOTE: *By clearing warnings and errors using Modbus, you can supplement any other analog outputs and alarms you have configured.*

Modbus Map

The following SUEZ Modbus map is provided for configuring M-Series Analyzers.

TABLE 16: SUEZ MODBUS MAP

Register Type	Description	Function 1 = Read coil status 2 = Read input status 3 = Read holding registers 4 = Read input registers 5 = Write single coil	Address	Notes
Discrete Inputs (read)	Status	2	1000	
	New Data			Bit 0
	Error			Bit 1
	Standby			Bit 2
	Alarm 1			Bit 3
	Alarm 2			Bit 4
	Alarm 3			Bit 5
	Alarm 4			Bit 6
Discrete Inputs (read)	Installed	2	1001	
	Check Standard			Bit 0
	Stream 1			Bit 1
	Stream 2			Bit 2
Discrete Inputs (read)	Activations	2	1002	

Appendix C WORKING WITH MODBUS

<i>Register Type</i>	<i>Description</i>	<i>Function</i> 1 = Read coil status 2 = Read input status 3 = Read holding registers 4 = Read input registers 5 = Write single coil	<i>Address</i>	<i>Notes</i>
Coils (read)	State	1	2000	
	Run			Bit 0 set
	Stop			Bit 1 set
Coils (read)	Stream 1 Enabled	1	2003	
	Stream 2 Enabled	1	2004	
	New Data Status	1	2009	
	Error Status	1	2010	
	Standby Status	1	2011	
	Alarm 1 Status	1	2012	
	Alarm 2 Status	1	2013	
	Alarm 3 Status	1	2014	
	Alarm 4 Status	1	2015	
	Stream 1 Installed	1	2017	
	Stream 2 Installed	1	2018	
	Activations Feature 1	1	2022	
	Activations Feature 2	1	2023	
	Activations Feature 3	1	2024	
Coils (write)	Run	5	2000	Write 1 to address 2000 to start analysis or write 1 to address 2001 to stop analysis
	Stop	5	2001	
	Set Online/Grab Mode	5	2010	Online = 1; Grab = 0
	Acknowledge All Errors/Warnings	5	2011	Write 1 to address 2011 to clear all current errors/warnings
Input Registers (read)	Instrument Family	4	3010	16 bit unsigned



Register Type	Description	Function 1 = Read coil status 2 = Read input status 3 = Read holding registers 4 = Read input registers 5 = Write single coil	Address	Notes
	Instrument Model	4	3011	16 bit unsigned
	Serial Number	4	3012	16 bit unsigned
	Firmware Version (Major)	4	3015	16 bit unsigned
	Firmware Version (Minor)	4	3016	16 bit unsigned
	Firmware Version (Engineering)	4	3017	16 bit unsigned
	Current Time - Year	4	3050	16 bit unsigned
	Current Time - Month	4	3051	16 bit unsigned
	Current Time - Day	4	3052	16 bit unsigned
	Current Time - Hour	4	3053	16 bit unsigned
	Current Time - Minute	4	3054	16 bit unsigned
	Current Time - Second	4	3055	16 bit unsigned
	Current Mode ("Possible Mode Values" on page 309.)	4	3099	16 bit unsigned
	ReadingTime-Year	4	3100	16 bit unsigned
	Reading Time - Month	4	3101	16 bit unsigned
	Reading Time - Day	4	3102	16 bit unsigned
	Reading Time - Hour	4	3103	16 bit unsigned
	Reading Time - Minute	4	3104	16 bit unsigned
	Reading Time - Second	4	3105	16 bit unsigned
	Error Type	4	3200	16 bit unsigned
	Error Time - Year	4	3201	16 bit unsigned
	Error Time - Month	4	3202	16 bit unsigned
	Error Time - Day	4	3203	16 bit unsigned
	Error Time - Hour	4	3204	16 bit unsigned
	Error Time - Minute	4	3205	16 bit unsigned
	Error Time - Second	4	3206	16 bit unsigned
	TOC Value Low Word	4	3300	16 bit unsigned; combine with High Word to create 32 bit floating pt.
	TOC Value High Word	4	3301	16 bit unsigned; combine with Low Word to create 32 bit floating pt.

Appendix C WORKING WITH MODBUS

<i>Register Type</i>	<i>Description</i>	<i>Function</i> 1 = Read coil status 2 = Read input status 3 = Read holding registers 4 = Read input registers 5 = Write single coil	<i>Address</i>	<i>Notes</i>
	TOC Units	4	3302	16 bit unsigned
	TOC Stream	4	3303	16 bit unsigned
	TC Value Low Word	4	3310	16 bit unsigned; combine with High Word to create 32 bit floating pt.
	TC Value High Word	4	3311	16 bit unsigned; combine with Low Word to create 32 bit floating pt.
	TC Units	4	3312	16 bit unsigned
	TC Stream	4	3313	16 bit unsigned
	IC Value Low Word	4	3320	16 bit unsigned; combine with High Word to create 32 bit floating pt.
	IC Value High Word	4	3321	16 bit unsigned; combine with Low Word to create 32 bit floating pt.
	IC Units	4	3322	16 bit unsigned
	IC Stream	4	3323	16 bit unsigned
	Sample Temp. Cond. Value Low Word	4	3500	16 bit unsigned; combine with High Word to create 32 bit floating pt.
	Sample Temp. Cond. Value High Word	4	3501	16 bit unsigned; combine with Low Word to create 32 bit floating pt.
	Sample Temp. Conductivity Units	4	3502	16 bit unsigned
	Raw Sample Cond. Value Low Word	4	3510	16 bit unsigned; combine with High Word to create 32 bit floating pt.
	Raw Sample Cond. Value High Word	4	3511	16 bit unsigned; combine with Low Word to create 32 bit floating pt.
	Raw Sample Conductivity Units	4	3512	16 bit unsigned



Register Type	Description	Function 1 = Read coil status 2 = Read input status 3 = Read holding registers 4 = Read input registers 5 = Write single coil	Address	Notes
	Sample Temp. Value Low Word	4	3700	16 bit unsigned; combine with High Word to create 32 bit floating pt.
	Sample Temp. Value High Word	4	3701	16 bit unsigned; combine with Low Word to create 32 bit floating pt.
	Sample Temperature Units	4	3702	16 bit unsigned
	Reading Time for Stream 1 - Year	4	4000	16 bit unsigned
	Reading Time for Stream 1 - Month	4	4001	16 bit unsigned
	Reading Time for Stream 1 - Day	4	4002	16 bit unsigned
	Reading Time for Stream 1 - Hour	4	4003	16 bit unsigned
	Reading Time for Stream 1 - Minute	4	4004	16 bit unsigned
	Reading Time for Stream 1 - Second	4	4005	16 bit unsigned
	TOC Value Low Word for Stream 1	4	4010	16 bit unsigned; combine with High Word to create 32 bit floating pt.
	TOC Value High Word for Stream 1	4	4011	16 bit unsigned; combine with Low Word to create 32 bit floating pt.
	TOC Units for Stream 1	4	4012	16 bit unsigned
	TC Value Low Word for Stream 1	4	4020	16 bit unsigned; combine with High Word to create 32 bit floating pt.
	TC Value High Word for Stream 1	4	4021	16 bit unsigned; combine with Low Word to create 32 bit floating pt.
	TC Units for Stream 1	4	4022	16 bit unsigned
	IC Value Low Word for Stream 1	4	4030	16 bit unsigned; combine with High Word to create 32 bit floating pt.

Appendix C WORKING WITH MODBUS

Register Type	Description	Function 1 = Read coil status 2 = Read input status 3 = Read holding registers 4 = Read input registers 5 = Write single coil	Address	Notes
	IC Value High Word for Stream 1	4	4031	16 bit unsigned; combine with Low Word to create 32 bit floating pt.
	IC Units for Stream 1	4	4032	16 bit unsigned
	Reading Time for Stream 2 - Year	4	4100	16 bit unsigned
	Reading Time for Stream 2 - Month	4	4101	16 bit unsigned
	Reading Time for Stream 2 - Day	4	4102	16 bit unsigned
	Reading Time for Stream 2 - Hour	4	4103	16 bit unsigned
	Reading Time for Stream 2 - Minute	4	4104	16 bit unsigned
	Reading Time for Stream 2 - Second	4	4105	16 bit unsigned
	TOC Value Low Word for Stream 2	4	4110	16 bit unsigned; combine with High Word to create 32 bit floating pt.
	TOC Value High Word for Stream 2	4	4111	16 bit unsigned; combine with Low Word to create 32 bit floating pt.
	TOC Units for Stream 2	4	4112	16 bit unsigned
	TC Value Low Word for Stream 2	4	4120	16 bit unsigned; combine with High Word to create 32 bit floating pt.
	TC Value High Word for Stream 2	4	4121	16 bit unsigned; combine with Low Word to create 32 bit floating pt.
	TC Units for Stream 2	4	4122	16 bit unsigned
	IC Value Low Word for Stream 2	4	4130	16 bit unsigned; combine with High Word to create 32 bit floating pt.
	IC Value High Word for Stream 2	4	4131	16 bit unsigned; combine with Low Word to create 32 bit floating pt.



Register Type	Description	Function	Address	Notes
		1 = Read coil status 2 = Read input status 3 = Read holding registers 4 = Read input registers 5 = Write single coil		
	IC Units for Stream 2	4	4132	16 bit unsigned

Notes:

- High/Low Word Values are IEEE 32-bit floats split into two 16-bit registers.
- TOC, TC, IC units are: 1=ppt, 2=ppb, 3=ppm
- Temperature units are: 1=°C, 2=°F, 3=°K
- Resistivity units are: 1=Ohm-cm, 2=kOhm-cm, 3=MOhm-cm
- Instrument Family: M9-Series/M5310 C=0x4400
- Instrument Model: Combined model and type: Pharma-Lab=1000, Pharma-Online=2000, Pharma-Portable=5001, Muni-Lab=1001, Muni-Online=2001, Muni-Portable=5001, Semi-Lab=1002, Semi-Online=2002, Semi-Portable=5002.
- Installed features are: 0=Not Installed, 1=Installed
- Enabled features are: 0=Disabled, 1=Enabled
- Reject units are: 0=Not Rejected, 1=Rejected
- Stream units are: -1=Check Standard, 0=Vial Port, 1=Stream 1, 2=Stream 2, 3=Stream 3, 4=Stream 4, 5=Stream 5
- Firmware Major is xx in xx.yy.zzz
- Firmware Minor is yy in xx.yy.zzz
- Firmware Engineering is zzz in xx.yy.zzz
- Measurement Mode: IC=10, TC=20, TOC=30
- Set On-Line/Grab Mode: On-Line = 1, Grab = 0

TABLE 17: POSSIBLE MODE VALUES

Register Type	Description
GRAB_MODE	0
ONLINE_MODE	1
TIMED_ONLINE_MODE	2
SINGLE_POINT_VERIFICATION_MODE	3
SAMPLE_COND_VERIFICATION_MODE	4
MULTI_POINT_VERIFICATION_MODE	5
AUTOREAGENT_VERIFICATION_MODE	6
ACCURACY_MODE // Accuracy/Precision	10
SYSTEM_SUITABILITY_MODE	11
ROBUSTNESS_MODE	12
SPECIFICITY_MODE	13
LINEARITY_MODE	14

Appendix C WORKING WITH MODBUS

Register Type	Description
SINGLE_POINT_CALIBRATION_MODE	15
SAMPLE_COND_CALIBRATION_MODE	16
VERIFICATION_MODE	17
NOT_USED_PRECISION_MODE	18
MULTI_POINT_CALIBRATION_MODE	19
TOC_REMOVAL_GRAB_MODE	20
TOC_REMOVAL_ONLINE_MODE	21
TOC_AUTOZERO	22
TC_IC_CELL_COND_AUTOZERO	23
ICR_VALIDATION	24
JP_PROTOCOL_MODE	25
STERILE_WATER_SUITABILITY_MODE	30
SAMPLE_COND_AUTOZERO_MODE	31

D

Appendix D: Streaming Data Via Ethernet

You can also stream comma-delimited text data through the Ethernet port. This will require a third-party communications software, such as the open-source PuTTY (an SSH and Telnet client), which is shown as an example in the following procedure.

To stream data via Ethernet

For each measurement, the Analyzer will output the measurement data for *Date*, *Time*, *TOC value in ppb*, *IC value in ppb*, and *TC value in ppb*.

The TOC value field may contain the string “<4.00 ppb,” if measured below the detection limit.

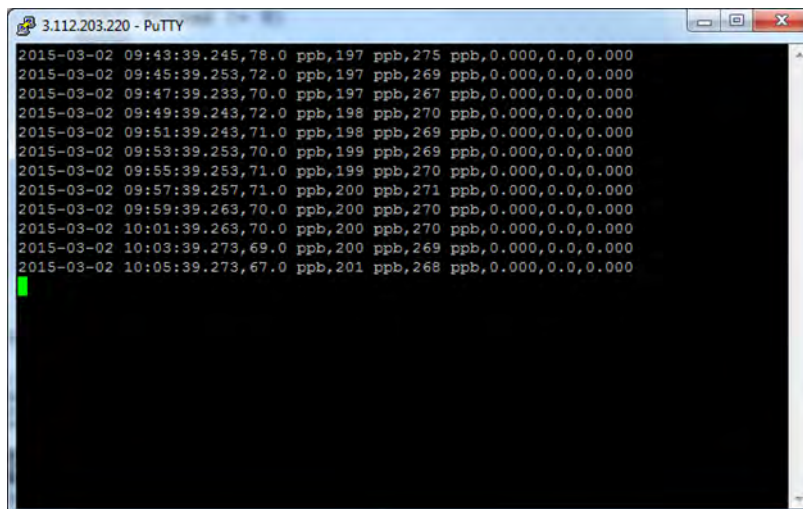

```
3.112.203.220 - PuTTY
2015-03-02 09:43:39.245,78.0 ppb,197 ppb,275 ppb,0.000,0.0,0.000
2015-03-02 09:45:39.253,72.0 ppb,197 ppb,269 ppb,0.000,0.0,0.000
2015-03-02 09:47:39.233,70.0 ppb,197 ppb,267 ppb,0.000,0.0,0.000
2015-03-02 09:49:39.243,72.0 ppb,198 ppb,270 ppb,0.000,0.0,0.000
2015-03-02 09:51:39.243,71.0 ppb,198 ppb,269 ppb,0.000,0.0,0.000
2015-03-02 09:53:39.253,70.0 ppb,199 ppb,269 ppb,0.000,0.0,0.000
2015-03-02 09:55:39.253,71.0 ppb,199 ppb,270 ppb,0.000,0.0,0.000
2015-03-02 09:57:39.257,71.0 ppb,200 ppb,271 ppb,0.000,0.0,0.000
2015-03-02 09:59:39.263,70.0 ppb,200 ppb,270 ppb,0.000,0.0,0.000
2015-03-02 10:01:39.263,70.0 ppb,200 ppb,270 ppb,0.000,0.0,0.000
2015-03-02 10:03:39.273,69.0 ppb,200 ppb,269 ppb,0.000,0.0,0.000
2015-03-02 10:05:39.273,67.0 ppb,201 ppb,268 ppb,0.000,0.0,0.000
```

Figure 73: PuTTY Screen

1. Connect an Ethernet cable to the Analyzer, as described in [“Installing an Ethernet Connection”](#) on page 68.

Appendix D STREAMING DATA VIA ETHERNET

2. Enable the Ethernet network on the Analyzer, as described in [“Configuring Ethernet Output” on page 80](#).
3. Enter the following settings in the PuTTY (or other third-party communications) software:
 - IP Address
 - Port #10801
 - Connection Type = Raw

E

Appendix E: Warning and Error Descriptions

.....

#	Warning/ Error	Name	Description
300	Warning	Acid container	The estimated volume of acid is less than 10%. Confirm the low acid volume and order a new acid container.
301	Warning	Acid container	The acid expiration date is within 15 days. Order new acid container.
302	Warning	Acid container	Acid volume is 0%. Order a new acid container.
303	Warning	Acid container	The acid reagent has expired. Order a new acid container.
304	Warning	Acid container	The acid reagent container is not detected. Please ensure that a SUEZ reagent product is installed.
400	Warning	Oxidizer container	The estimated volume of oxidizer is less than 10%. Confirm the low oxidizer volume and order a new oxidizer container.
401	Warning	Oxidizer container	The oxidizer expiration date is within 15 days. Order a new oxidizer container.
402	Warning	Oxidizer container	The oxidizer volume is 0%. Order a new oxidizer container.
403	Warning	Oxidizer container	The oxidizer reagent has expired. Order a new oxidizer container.
404	Warning	Oxidizer container	The oxidizer reagent container is not detected. Please ensure that a SUEZ reagent product is installed.
500	Warning	UV lamp	The estimated remaining lamp life is less than 15 days. Order a new UV lamp.
502	Warning	UV lamp	UV lamp has expired. Order and install a new UV lamp.
600	Warning	IC Sample Pump	The estimated remaining IC sample pump tube life is less than 15 days. Order new pump tubing.

Appendix E WARNING AND ERROR DESCRIPTIONS

#	Warning/Error	Name	Description
601	Warning	IC Sample Pump	The IC sample pump tube life has expired. Install new pump tubing.
602	Warning	TC Sample Pump	The estimated remaining TC sample pump tube life is less than 15 days. Order new pump tubing.
700	Warning	Resin bed	The estimated remaining resin bed life is less than 15 days. Order a new resin bed.
701	Warning	Resin bed	The resin bed has expired. Install a new resin bed.
1201	Error	IC analog	The IC analog reading is out of range - High.
1202	Warning	IC analog	The IC analog reading is out of range - Low.
1203	Error	IC analog	The IC temperature analog reading is out of range.
1204	Error	IC analog	The IC conductivity analog reading is out of range.
2300	Warning	Measurement	The TOC Autozero failed because TOC measurements are not stable enough to calculate an accurate TOC offset. Check the incoming sample stream for stability and perform diagnostics.
2403	Warning	Acid Syringe	Bubble detected in acid syringe. If problem persists check the acid level and flush the syringe.
2500	Error	Flash Memory	The instrument has encountered a system error. Please follow the shutdown procedure and power cycle the instrument. If the problem persists, please contact Technical Support or your local service provider.
3100	Warning	DI loop	Low DI water reservoir level ¹ detected. Fill the DI water reservoir.
3101	Error	DI flow - IC	Restricted IC channel DI water flow detected. Perform diagnostics.
3102	Warning	DI flow - IC	IC channel DI water flow is not detected. Perform diagnostics.
3103	Error	DI flow - TC	Restricted TC channel DI water flow detected. Perform diagnostics.
3104	Warning	DI flow - TC	TC channel DI water flow is not detected. Perform diagnostics. The instrument has encountered a system error. Please follow the shutdown procedure and power cycle the instrument. If the problem persists, please contact Technical Support or your local service provider.
3105	Error	DI flow - IC	The instrument has encountered a system error. Please follow the shutdown procedure and power cycle the instrument. If the problem persists, please contact Technical Support or your local service provider.
3106	Error	DI flow - TC	The instrument has encountered a system error. Please follow the shutdown procedure and power cycle the instrument. If the problem persists, please contact Technical Support or your local service provider.



#	Warning/Error	Name	Description
3107	Warning	DI Loop	DI reservoir level sensor ¹ failed. Please contact Technical Support or your local service provider.
3108			
¹ Reservoir level sensor only implemented with DI reservoirs installed after January 2018			
			DI loop sensor only implemented with DI reservoirs installed after January 2018.
3201	Error	TC analog	The instrument has encountered a system error. Please follow the shutdown procedure and power cycle the instrument. If the problem persists, please contact Technical Support or your local service provider.
3202	Warning	TC analog	The instrument has encountered a system error. Please follow the shutdown procedure and power cycle the instrument. If the problem persists, please contact Technical Support or your local service provider.
3203	Error	TC analog	The instrument has encountered a system error. Please follow the shutdown procedure and power cycle the instrument. If the problem persists, please contact Technical Support or your local service provider.
3204			

Appendix E WARNING AND ERROR DESCRIPTIONS

#	Warning/ Error	Name	Description
4000			
4001			
4002			
4003			
4004			
4005			
4006			
4007			
4008			
4100			
4101			
4102			
4103			
4104			
4105			
4106			
4107	Error	System Error	The instrument has encountered a system error. Please follow the shutdown procedure and power cycle the instrument. If the problem persists, please contact Technical Support or your local service provider.
4108			
4109			
4110			
4111			
4112			
4113			
4114			
4115			
4200			
4201			
4202			
4203			
4204			
4205			
4206			
4207			
4208			



#	Warning/ Error	Name	Description
4209			
4210			
4211			
4212			
4213			
4214			
4215			
4216			
4217			
4218			
4219			
4220			
4221			
4222			
4223			
4224			
4225	Error	System Error	The instrument has encountered a system error. Please follow the shutdown procedure and power cycle the instrument. If the problem persists, please contact Technical Support or your local service provider.
4226			
4227			
4264			
4265			
4266			
4267			
4268			
4269			
4270			
4271			
4272			
4273			
4274			
4275			
4276			
4277			
4278			

Appendix E WARNING AND ERROR DESCRIPTIONS

#	Warning/Error	Name	Description
4300	Error	System Error	The instrument has encountered a system error. Please follow the shutdown procedure and power cycle the instrument. If the problem persists, please contact Technical Support or your local service provider.
4400			
5000	Error	System Error	The instrument is unable to calibrate. Please contact Technical Support or your local service provider.
5501	Warning	ICR Inlet Valve	Low current in the ICR inlet valve detected.
5502	Warning	ICR Bypass Valve	Low current in the ICR by-pass valve detected.
5503	Warning	Sample Valve	Low current in the sample valve detected.
5504	Error	ICR Inlet Valve	The ICR inlet valve current is out of range. Unable to perform system protocol.
5505	Error	ICR Bypass Valve	The ICR by-pass valve current is out of range. Unable to perform system protocol.
5507	Warning	ICR Inlet Valve	High current in the ICR inlet valve detected.
5508	Warning	ICR Bypass Valve	High current in the ICR by-pass valve detected.
5509	Warning	Sample Valve	High current in the sample valve detected.
5600	Error	Acid syringe	Unexpected empty position is detected on the acid syringe. Perform diagnostics.
5601	Error	Acid syringe	Acid syringe empty position is not detected. Perform diagnostics.
5602	Error	Acid syringe	Acid syringe movement is not detected. Perform diagnostics.
5603	Error	Acid motor	Low current in the acid syringe pump motor is detected.
5604	Error	Acid Valve	Low current in the acid valve is detected.
5605	Error	Acid Valve	High current in the acid valve is detected.
5606	Error	Acid Motor	Low current in the acid motor is detected.
5607	Error	Acid Motor	High current in the acid motor is detected.
5608	Error	Acid Detector Drive	Low current in the acid detector drive is detected.
5609	Error	Acid Detector Drive	High current in the acid detector drive is detected.
5700	Error	Oxidizer syringe	Unexpected empty position is detected on the oxidizer syringe. Perform diagnostics.
5701	Error	Oxidizer syringe	Oxidizer syringe empty position is not detected. Perform diagnostics.
5702	Error	Oxidizer syringe	Oxidizer syringe movement is not detected. Perform diagnostics.
5703	Error	Oxidizer motor	Low current in the oxidizer syringe pump motor is detected.
5704	Error	Oxidizer Valve	Low current in the oxidizer valve is detected.
5705	Error	Oxidizer Valve	High current in the oxidizer valve is detected.



#	Warning/Error	Name	Description
5706	Error	Oxidizer Motor	Low current in the oxidizer motor is detected.
5707	Error	Oxidizer Motor	High current in the oxidizer motor is detected.
5708	Error	Oxidizer Detector Drive	Low current in the oxidizer detector drive is detected.
5709	Error	Oxidizer Detector Drive	High current in the oxidizer detector drive is detected.
5800	Error	DI Pump	Low current in the DI pump is detected.
5801	Error	Stream Valve	Low current in the stream select valve is detected.
5802	Error	DI Pump	High current in the DI pump is detected.
5803	Error	Stream Valve	High current in the stream select valve is detected.
5804	Error	IC/TC Valve	Low current in the IC/TC valve is detected.
5805	Error	IC/TC Valve	High current in the IC/TC valve is detected.
5806	Error	DI Loop Fan	Low current in the DI loop fan is detected.
5807	Error	DI Loop Fan	High current in the DI loop fan is detected.
5900	Warning	IOS Vial Port	No vial detected in the iOS vial port.
6501	Error	System Error	The system has detected a processor problem. Please contact Technical Support or your local service provider.
6800	Warning	UV lamp	UV lamp failed. Please replace the UV lamp.
6900	Warning	IC sample pump	IC sample flow not detected. Perform diagnostics.
6901	Error	IC sample pump	Low current in the IC sample pump motor is detected.
6902	Error	IC sample pump	High current in the IC sample pump motor is detected.
6903	Warning	IC sample pump	IC Sample flow sensor failed. Please contact Technical Support or your local service provider.
6904	Warning	IC sample pump	IC Sample flow sensor failed. Please contact Technical Support or your local service provider.
7000	Warning	TC sample pump	TC sample flow is not detected. Perform diagnostics.
7001	Error	TC sample pump	Low current in the TC sample pump motor is detected.
7002	Error	TC sample pump	High current in the TC sample pump motor is detected.
7003	Warning	TC sample pump	TC Sample flow sensor failed. Please contact Technical Support or your local service provider.
7004	Warning	TC sample pump	TC Sample flow sensor failed. Please contact Technical Support or your local service provider.
7100	Warning	IC Sample Flow	Air detected in the IC sample flow path. Check for sufficient sample, verify protocol settings, and perform diagnostics.
7101	Warning	IC Sample Flow	Low IC sample flow detected. Perform diagnostics.
7200	Warning	TC Sample Flow	Air detected in the TC sample flow path. Check for sufficient sample, verify protocol settings, and perform diagnostics.
7201	Warning	TC Sample Flow	Low TC sample flow detected. Perform diagnostics.
7300	Warning	Measurement	Conductivity Autozero failed. Perform diagnostics.
7501	Warning	Fluidics	Fluidics Module Stopped Responding.

Appendix E WARNING AND ERROR DESCRIPTIONS

#	Warning/Error	Name	Description
7502	Warning	Dual Conductivity	Dual conductivity Module Stopped Responding.
7505	Warning	I/O Module	I/O Module Stopped Responding/
10001	Warning	USB Key	USB Key is not detected. Please insert a USB key and try again.
10002	Warning	USB Key	Unable to create directory Sievers on the USB key for export.
10003	Warning	USB Key	Unable to open a file on USB key. Make sure the USB key is not locked.
10004	Warning	USB Key	File does not exist on the USB key. Ensure the correct USB key is inserted and try again.
10005	Error	Flash Memory	Unable to open a file on flash memory. Flash memory may be corrupted. If the problem persists, please contact Technical Support or your local service provider.
10006	Error	Flash Memory	Unable to open a file on flash memory. Flash memory may be corrupted. If the problem persists, please contact Technical Support or your local service provider.
10007	Error	Flash Memory	There is no log directory on the data card. Flash memory may be corrupted. If the problem persists, please contact Technical Support or your local service provider.
10008	Warning	USB Key	Unable to open a file on USB key. Ensure the correct USB key is inserted and try again.
10009	Error	RAM Disk	Unable to write to a file on the RAM disk. The RAM disk may be corrupted. If the problem persists, please contact Technical Support or your local service provider.
10010	Warning		The option selected is not valid.
10011	Error	Flash Memory	The directory does not exist on flash memory. Flash memory may be corrupted. If the problem persists, please contact Technical Support or your local service provider.
10012	Warning		The instrument has encountered a system error. Please power cycle the instrument. If the problem persists, please contact Technical Support or your local service provider.
10013	Warning		Command issued by DataPro contains protocol type specified not supported or invalid.
10014	Warning		The instrument has encountered a system error. Please power cycle the instrument. If the problem persists, please contact Technical Support or your local service provider.
10015	Error	Flash Memory	File does not exist on flash memory. Flash memory may be corrupted. If the problem persists, please contact Technical Support or your local service provider.



#	Warning/Error	Name	Description
10016	Warning		The instrument has encountered a system error. Please power cycle the instrument. If the problem persists, please contact Technical Support or your local service provider.
10017	Error	RAM Disk	Unable to open a file on the RAM disk. The RAM disk may be corrupted. If the problem persists, please contact Technical Support or your local service provider.
10018	Error	Flash Memory	The instrument has encountered a system error. Please follow the shut down procedure and power cycle the instrument. If the problem persists, please contact Technical Support or your local service provider.
10020	Warning	IOS Flow Sensor	Sample flow detected in IOS Flow Sensor for the Stream. Analysis is resumed.
10036	Warning	System Error	The instrument has encountered a system error. Please power cycle the instrument. If the problem persists, please contact Technical Support or your local service provider.
10037	Warning	USB Key	The directory does not exist on the USB key.
10038	Error	Flash Memory	Unable to delete a file on flash memory. Flash memory may be corrupted. If the problem persists, please contact Technical Support or your local service provider.
10039	Warning	USB Key	There are too many files in the export directory on USB the key. Please clean up the directory by remaining files and try again.
10040	Warning	USB Key	The USB key does not contain the Sievers directory. Ensure the correct USB key is inserted and try again.
10041	Warning		Please select an option.
10042	Warning		The instrument has encountered a system error. Please power cycle the instrument. If the problem persists, please contact Technical Support or your local service provider.
10043	Error	RAM Disk	File does not exist on the RAM disk. The RAM disk may be corrupted. If the problem persists, please contact Technical Support or your local service provider.
10044	Error	Flash Memory	Unable to write to a file on flash memory. Flash memory may be corrupted. If the problem persists, please contact Technical Support or your local service provider.
10045	Error	Flash Memory	The secondary micro SD card slot is not recognized or partitions are not corrected mapped. Flash memory may be corrupted. If the problem persists, please contact Technical Support or your local service provider.
10046	Warning		There is no item selected. Please select at least one item.

Appendix E WARNING AND ERROR DESCRIPTIONS

#	Warning/Error	Name	Description
10047	Warning		It has been 8 hours since the last time the oxidizer was used during an analysis or the reagent flush has been performed. Please perform the reagent flush.
10048	Warning		It has been 8 hours since the last time the oxidizer was used during an analysis or the reagent flush has been performed. Press Yes to perform the reagent flush now or No to continue.
10049	Warning		No activation records for the instrument are present in the USB key. Ensure the correct USB key is inserted and try again.
10050	Warning		No count based activation records are present in the USB key. Ensure the correct USB key is inserted and try again.
10051	Warning		The instrument has encountered a system error. Please power cycle the instrument. If the problem persists, please contact Technical Support or your local service provider.
10052	Error		The instrument has encountered a system error. Please power cycle the instrument. If the problem persists, please contact Technical Support or your local service provider.
10053	Warning		Insufficient space remains on the USB key. Please use a different USB key.
10054	Warning		There are no database backup files on the USB key. Ensure the correct USB key is inserted and try again.
10055	Error		The system cannot recover. Please power cycle the instrument. If the problem persists, please contact Technical Support or your local service provider.
10056	Error		Calibration result is not available. Please check the connection to the instrument controller.
10057	Warning		The instrument has encountered a system error. Please power cycle the instrument. If the problem persists, please contact Technical Support or your local service provider.
10058	Warning		Unable to complete the request from either DataPro or via the diagnostics port. The instrument is currently running an analysis.
10059	Warning		Unable to complete the request. The instrument is currently measuring the last vial.
10060	Warning		IC is greater than TC. Perform a TOC Autozero. If the problem persists, perform a TC/IC Cell Conductivity Autozero.
10061	Warning		IC is less than zero. Perform a TC/IC Cell Conductivity Autozero.



#	Warning/Error	Name	Description
10062	Warning		TC is less than zero. Perform a TOC Autozero. If the problem persists, perform a TC/IC Cell Conductivity Autozero.
10063	Warning		Failed to enter the correct password. Contact Technical Support for the Password of the Day. Prepare to provide the Security Code on the screen.
10064	Warning		A single user may not have all roles assigned.
10065	Warning		The user entered does not have sufficient privilege to perform the task. Please enter another user.
10066	Warning		No user roles are configured for the user level. User roles must be configured as soon as possible.
10067	Warning		No users exist in the system. Users must be created as soon as possible.
10068	Warning		FSE Certification License has expired. Please contact Technical Support for renewal.
10069	Warning		License entered is invalid. Please check the information and try again. If the problem persists, please contact Technical Support.
10070	Warning		Measurement cycle time currently configured is not sufficient to run the analysis. Please increase the cycle time.
10071	Warning		The instrument has encountered a system error. Please power cycle the instrument. If the problem persists, please contact Technical Support or your local service provider.
10072			
10073	Warning		The system clock is not correctly set.
10074	Warning		The password has expired. Please reset your password.
10075	Warning		The instrument has encountered a system error. Please power cycle the instrument. If the problem persists, please contact Technical Support or your local service provider.
10076			
10077			
10078			
10079			
10080			
10081			
10082			
10083			

Appendix E WARNING AND ERROR DESCRIPTIONS

#	Warning/Error	Name	Description
10084	Error	IOS Flow Sensor	No sample flow detected in iOS Flow Sensor for Stream 1. Analysis is stopped.
10085	Error	IOS Flow Sensor	No sample flow detected in iOS Flow Sensor for Stream 2. Analysis is stopped.
10086	Warning	IOS Flow Sensor	Sample flow detected in iOS Flow Sensor for Stream 1. Analysis is resumed.
10087	Warning	IOS Flow Sensor	Sample flow detected in iOS Flow Sensor for Stream 2. Analysis is resumed.
10088	Warning		There may be one or more missing measurements due to system error.
10089	Warning		The instrument has encountered a system error. Please power cycle the instrument.
10090		If the problem persists, please contact Technical Support or your local service provider.	
10091	Error	IOS Flow Sensor	Stream 1 is disabled. Please enable the stream before continuing.
10092	Error	IOS Flow Sensor	Stream 2 is disabled. Please enable the stream before continuing.
10093	Error	IOS Flow Sensor	In order to perform TOC Removal Online measurements, both streams must be enabled. Please enable both streams before continuing.
10094	Error	IOS Flow Sensor	Both iOS flow sensors detected no flow. Analysis is stopped.
10095	Error	IOS Flow Sensor	Either stream 1 is disabled or the flow sensor detected no flow. Please check stream 1.
10096	Error	IOS Flow Sensor	Either stream 2 is disabled or the flow sensor detected no flow. Please check stream 2.
10097	Warning		A new acid reagent cartridge is installed. The lot number is %1.
10098	Warning		A new oxidizer reagent cartridge is installed. The lot number is %1.
10099	Error	RAM Disk	Unable to delete a file on RAM disk. RAM disk may be corrupted. If the problem persists, please contact Technical Support or your local service provider.
10101	Error		The instrument has encountered a USB communication error to the instrument controller. Please power cycle the instrument. If the problem persists, please contact Technical Support or your local service provider.
10103	Warning		The instrument has encountered a USB communication error to the instrument controller. Please power cycle the instrument. If the problem persists, please contact Technical Support or your local service provider.



#	Warning/Error	Name	Description
10104	Warning		The instrument has encountered a system error during firmware upgrade. Please power cycle the instrument. If the problem persists, please contact Technical Support or your local service provider.
10105			
10106			
10107			
10108	Warning		Command issued by DataPro contains an insufficient number of arguments.
10109	Warning		Command via diagnostics port contains an insufficient number of arguments.
10110	Error		The instrument controller initiated command contains an insufficient number of arguments. A power cycle may be required to reset the instrument controller.
10111	Error		The instrument controller initiated command contains invalid arguments. A power cycle may be required to reset the instrument controller.
10112	Warning		Command issued by DataPro contains invalid arguments.
10113	Warning		Command via diagnostics port contains invalid arguments.
10114	Error	Vial Door	The vial port door is opened. Please close the vial port door to run an analysis using the Autosampler.
10115	Error	Vial Door	The iOS vial port door is opened. Please close the iOS vial port door to run an online analysis.
10116	Error	Vial Door	The vial port door is opened. Please close the vial port door to run a continuous analysis.
10117	Warning	Acid Reagent	The acid reagent cartridge has been used. Please install a new acid reagent cartridge.
10118	Warning	Oxidizer Reagent	The oxidizer reagent cartridge has been used. Please install a new oxidizer reagent cartridge.
10119	Error	Sample Flow	No sample flow detected in iOS Flow Sensor for the Stream. Analysis is stopped.
10121	Warning	Sample Flow	No sample flow detected in iOS Flow Sensor for Stream 1. Analysis will continue on Stream 2.
10122	Warning	Sample Flow	No sample flow detected in iOS Flow Sensor for Stream 2. Analysis will continue on Stream 1.
10123	Warning	TOC Reading	The RW or Blank TOC reading is unexpectedly high.
10124	Warning	TOC Reading	The RW or Blank TOC reading is unexpectedly high.

Appendix E WARNING AND ERROR DESCRIPTIONS

#	Warning/Error	Name	Description
10125	Warning	iOS Flow Sensor	No sample flow detected in IOS Flow Sensor for the Stream. Analysis will stop after a delay. Note: When this warning is issued, the measurement continues for the delay specified. When the timer expires, if the flow does not return and the analysis needs to be stopped, the 4-20 mA alarm output will go into Standby mode.
10201	Warning	Database	The content of database has been modified.
10202	Warning	Database	The instrument has encountered a system error while accessing the database. Please follow the shutdown procedure and power cycle the instrument. If the problem persists, please contact Technical Support or your local service provider.
10203			
10204			
10205			
10206			
10208			
10209			
10210			
10211			
10212			
10213			
10214			
10215			
10216			
10217			
10218			
10219			
10220			
10221			
10222			
10223			
10231			
10232			
10233			
10234			
10235			
10236			
10238	Error	Database	The database table is full. Archive the database before continuing.



#	Warning/Error	Name	Description
10239	Warning	Database	The database table is full. The oldest record will be removed.
10240	Warning	Database	The instrument has encountered a system error while accessing the database. Please follow the shutdown procedure and power cycle the instrument. If the problem persists, please contact Technical Support or your local service provider.
10241			
10242	Warning	Database	The current instrument firmware requires a previous version of the database. Upgrade the instrument firmware to the latest version before continuing.
10243	Warning	Database	The instrument has encountered a system error while accessing the database. Please follow the shutdown procedure and power cycle the instrument. If the problem persists, please contact Technical Support or your local service provider.
10244			
10247	Warning	Database	Number of methods allowed for this type reached the maximum. Please delete infrequently used methods.
10248	Error	Database	The result database table is full. Archive the database before continuing.
10249	Error	Database	The error history database table is full. Archive the database before continuing.
10250	Error	Database	The user database table is full. Archive the database before continuing.
10251	Error	Database	The audit trail database table is full. Archive the database before continuing.
10252	Error	Database	The service database table is full. Archive the database before continuing.
10253	Error	Database	The protocol database table is full. Archive the database before continuing.
10254	Warning	Database	The database table is at 75% capacity. Archive the database at earliest convenience.
10255	Warning	Database	The database table is at 90% capacity. Archive the database as soon as possible.

Appendix E WARNING AND ERROR DESCRIPTIONS

#	Warning/Error	Name	Description
10256	Warning	Database	The database table is at 95% capacity. When the database reaches 100% capacity, the oldest record will be removed. Archive the database.
10257	Warning	Database	The database table is at 99% capacity. When the database reaches 100% capacity, the oldest record will be removed. Archive the database.
10258	Warning	Database	The instrument has encountered a system error while accessing the database. Please power cycle the instrument. If the problem persists, please contact Technical Support or your local service provider.
10259			
10260	Warning	Database	The database table is at 95% capacity. When the database reaches 100% capacity, analysis will be disabled. Archive the database.
10261	Warning	Database	The database table is at 99% capacity. When the database reaches 100% capacity, analysis will be disabled. Archive the database.
10263	Warning	Database	The user entered is obsolete. Please enter another user ID.
10264	Warning	Database	The user entered is inactive. Please enter another user ID.
10265	Warning	Database	The instrument has encountered a system error while accessing the database. Please power cycle the instrument. If the problem persists, please contact Technical Support or your local service provider.
10266			
10267			
10268	Warning	Database	Record already exists in the database table.
10269	Error	Database	Both primary and backup databases are corrupted and unreadable. Upon restart, try recovering databases from the latest database backup file. If the problem persists, please contact Technical Support or your local service provider.
10270	Error	Database	The instrument has encountered a system error while accessing the database. Please follow the shutdown procedure and power cycle the instrument. If the problem persists, please contact Technical Support or your local service provider.
10271	Error	Database	The instrument has encountered a system error. Please follow the shutdown procedure and power cycle the instrument. Please power cycle the instrument. If the problem persists, please contact Technical Support or your local service provider.
10272			
10273	Error	Database	The instrument has encountered a system error while accessing the database. Please follow the shutdown procedure and power cycle the instrument. If the problem persists, please contact Technical Support or your local service provider.



#	Warning/Error	Name	Description
10274	Warning	Database	Scheduled Database Backup is overdue. Please backup the database as soon as possible.
10275	Warning	Database	Scheduled Database Archive is overdue. Please archive the database as soon as possible.
10276	Warning	Database	The instrument has encountered a system error while accessing the database. Please follow the shutdown procedure and power cycle the instrument. If the problem persists, please contact Technical Support or your local service provider.
10277	Warning	Database	Version information is missing for Error Occurrence database table.
10278	Error	Database	The primary database file is corrupted and unreadable. Upon restart, the system will try to recover from backup database. If the problem persists, please contact Technical Support or your local service provider.
10279	Error	Database	The secondary database file is corrupted and unreadable. Upon restart, the system will try to recover from primary database. If the problem persists, please contact Technical Support or your local service provider.
10301	Error		The instrument has encountered a USB communication error to the instrument controller. Please follow the shutdown procedure and power cycle the instrument. If the problem persists, please contact Technical Support or your local service provider.
10302			
10303			
10304	Warning		The upgrade USB key is not detected. Please insert the upgrade USB key and try again.
10307	Warning		Failed to upgrade firmware.
10309	Warning		The instrument has encountered a system error during firmware upgrade. Please follow the shutdown procedure and power cycle the instrument. If the problem persists, please contact Technical Support or your local service provider.
10310	Error		The instrument has encountered a system error during firmware upgrade. Please follow the shutdown procedure and power cycle the instrument. If the problem persists, please contact Technical Support or your local service provider.
10311	Error		The instrument has encountered a USB communication error to the instrument controller. Please follow the shutdown procedure and power cycle the instrument. If the problem persists, please contact Technical Support or your local service provider.
10312			
10313			
10314			
10315			
10316			

Appendix E WARNING AND ERROR DESCRIPTIONS

#	Warning/Error	Name	Description
10317	Error		During the firmware upgrade, the connection to Fluidics Module was not found. Please export diagnostics and contact Technical Support or your local service provider.
10318	Error		During the firmware upgrade, the connection to TC/IC Conductivity Module was not found. Please export diagnostics and contact Technical Support or your local service provider.
10320	Error		During the firmware upgrade, the connection to I/O Module was not found. Please export diagnostics and contact Technical Support or your local service provider.
10323	Warning	System Check	The instrument has encountered an error during system check. Please follow the shutdown procedure and power cycle the instrument. If the problem persists, please contact Technical Support or your local service provider.
10324			
10325			
10326			
10327			
10329	Warning	System Check	The instrument has encountered an error during system check. Please follow the shutdown procedure and power cycle the instrument. If the problem persists, please contact Technical Support or your local service provider.
10330			
10331			
10333			
10334			
10335			
10336	Warning		The instrument has encountered a system error during firmware upgrade. Please follow the shutdown procedure and power cycle the instrument. If the problem persists, please contact Technical Support or your local service provider.



#	Warning/Error	Name	Description
10337	Warning	System Check	The instrument has encountered an error during system check. Please follow the shutdown procedure and power cycle the instrument. If the problem persists, please contact Technical Support or your local service provider.
10338			
10339			
10340			
10341			
10342			
10343			
10344			
10345			
10346			
10347			
10348			
10349			
10350			
10351			
10352			
10353			
10502	Error	Autosampler	The instrument has encountered an Autosampler error. Please follow the shutdown procedure and power cycle the instrument and the Autosampler. If problem the persists, please contact Technical Support or your local service provider.
10503			
10504			
10505			
10506			
10507			
10508	Error	Autosampler	The Autosampler is unable to lower the needle. Please check for any blockage.
10509	Error	Autosampler	The instrument has encountered an Autosampler error. Please follow the shutdown procedure and power cycle the instrument and the Autosampler. If problem the persists, please contact Technical Support or your local service provider.
10510			
10511			
10512			
10513			
10516	Error	Autosampler	Autosampler returned error INVALID_COMMAND_ERROR

Appendix E WARNING AND ERROR DESCRIPTIONS

#	Warning/Error	Name	Description
10517	Error	Autosampler	The instrument has encountered an Autosampler error. Please follow the shutdown procedure and power cycle the instrument and the Autosampler. If problem the persists, please contact Technical Support or your local service provider.
10518			
10519			
10520			
10521			
10522			
10523			
10524			
10600			
10601			
10701			
10702	Error	Autosampler	The connection to the Autosampler is lost. Please check the cable or the connection.
10703	Error	Autosampler	The connection to the Autosampler has timed out. Please check the cable or the connection.
10704	Error	Autosampler	Unable to connect to the Autosampler. Please check your cable or make sure the Autosampler is turned on.
10705	Error	Autosampler	The instrument has encountered an Autosampler error. Please follow the shutdown procedure and power cycle the instrument and the Autosampler. If problem the persists, please contact Technical Support or your local service provider.
10706			
10707			
10708			
10709	Error	Autosampler	Autosampler model is not supported.
10710	Error	Autosampler	The vial size specified is not supported by the Autosampler model.
10711	Warning	Autosampler	The Autosampler is unable to lower the needle. Please check for any blockage. The analysis will continue on the next vial.
10801	Warning	DataGuard	The First Name field must not be empty.
10802	Warning	DataGuard	The Last Name field must not be empty.
10803	Warning	DataGuard	The User ID field must not be empty.
10804	Warning	DataGuard	The Password field must not be empty.
10805	Warning	DataGuard	The length of the User ID is too short.
10806	Warning	DataGuard	The length of the User ID is too long.
10807	Warning	DataGuard	The password entered does not match.
10808	Warning	DataGuard	The length of the password is too short.
10809	Warning	DataGuard	The length of the password is too long.



#	Warning/Error	Name	Description
10810	Warning	DataGuard	The password must include at least one numeric characters.
10811	Warning	DataGuard	The password must include at least one uppercase letters.
10812	Warning	DataGuard	Please re-enter the password.
10813	Warning	DataGuard	The password must include at least one special character (_ or -).
10814	Warning	DataGuard	First Name or Last Name must be less than 30 characters.
10815	Warning	DataGuard	The User ID entered already exist.
10816	Warning	DataGuard	The first and last names entered already exist. The name must be unique.

THIS PAGE IS INTENTIONALLY LEFT BLANK.

Index

Numerics

21 CFR Part 11 35
4-20 mA outputs 53, 82

A

AC power 62
acid
 replace cartridge 186
analysis times 111
analyzer settings 76
archive viewer 136
archiving database
 automatic 79
 manual 135
 reminder 78
Autoreagent 97, 106
Autoreagent Mode 110
Autoreagent Verification 150, 152
Autosampler communication problems
 reset connections 226

B

backflush 233
backing up database
 manual 135
 reminder 78
binary input 53, 57, 58, 59, 84
bubbles, reagent lines or syringes 236

C

calibration 35, 149
 annual 182
Calibration Supplies 150
clean the touchscreen 134
cleaning the Analyzer 133
clearance 41
Clock 125
CO₂ Transfer Module 31
Configuration Screen 119
configuring
 4-20 mA calibration 129

 4-20 mA output 129
 binary input 129
 I/O Setup 129
 printer 126, 130
 sensors and switches 128
connection problems 226
consumables
 expiration 181
 levels 112
 monitoring 180
 replacement schedule 182
Continuous mode 105

D

Data View Screen 140
database archive
 automatic 79
 manual 135
 reminder 78
database backup
 manual 135
 reminder 78
database check 218
database restore
 manual 137
database usage
 checking 143
DataPro2 Software 69
DI pump 32, 49, 65, 228
DI water reservoir 49, 50, 52
diagnostics 230
Disable Consumable Warning 122
Disable Warning Display 122
DP2 communication problems
 reset connection 226
Dual Conductivity Signal Processor 33

E

Effluent 100, 102
electronics subsystem 33
Enable ICR in TOC Autozero 156
environment preferences 79, 80, 121
error history 131

Index

error icon 113
error or warning message 113
Errors and Warnings
 acknowledging 220
 clearing 220
 clearing with Modbus 303
 reviewing 218
Ethernet 67, 68, 311
expiration dates
 renewing 185
export
 system settings 82
 system settings (constants) 153
 user-defined method details 118

F

failures 217
Filling fixture 50
firmware
 confirm version 143
 updating 135
flow rate 110
flow rate adjustment screw 73
flow sensors
 iOS, TC, IC 128
fluidics 233
fluidics module 33
flush and rinse 85
fuse 224

G

green dot 110

H

Help Screen 143
Home Screen 95
host port 67

I

I/O Control Wiring 53
IC 31

IC stream 32
ICR 30, 32, 111
 enabling in TOC Autozero 156
ICR consumables
 replacing 186
ICR Degasser 209, 210
inactivity timeout 77
Influent 100
inlet tubing 71, 233
install power 61
interior view 176
iOS 29, 30, 71, 92
iOS flow sensor 128
iOS sample inlet 73
IP address 143

K

keyword search 124

L

language 122
login attempts 77

M

MAC address 143
maintenance
 annual 154, 182
 monitoring consumables 180
 overview 175
 performing routine tasks 211
 replacing ICR consumables 208
 replacing other consumables 195
 replacing reagents 186
Maintenance Screen 131
Membrane Conductometric 31
method details
 export 118
 method name 108
Modbus 68
 introduction 301
 SUEZ map 303
mounting the Analyzer 41

Index

mouse 34
 installing 69
 setting up 81

N

name an Analyzer Location 78

O

O2 Transfer manifold 33
On-Line Timed Measurement 103
oxidizer
 replace cartridge 186

P

packing list 38
password 145
 change 147
Password Protection 145
 configure settings 142
 disable 146
 enable 146
persulfate 31
pinout table 55
power conduit 62, 63
power failure polarity 84
power off 64
prime the DI pump 52
prime the DI Water pump 65
printer 34, 67, 70, 80
Protocols Screen 115

R

reagent cartridge 44, 46, 47, 48
reagent cartridges 76
reagent cartridges, replacing 186
reagent rate 110
Reagent Syringes 211
reagents
 replacing 186
red dot 110
Rejects 98

reminder
 database archive, backup 78
remote start 57
Repeats 98, 106
reservoir water level 66
reset communications
 to Autosampler 226
 to DataPro2 226
reset connection
 to Autosampler 226
 to DataPro2 226
reset settings 140
resin cartridge 66
resolving connection problems
 with the Sievers Autosampler 132
restore settings 139
restoring database
 manual 137
result preferences 120
rinse method 88
Run a sample analysis 108, 117

S

sample inlet 32, 73
sample pump heads 202
sample pumps 229
secure data 35
Security tab 147
Security/DataGuard Screen 142
self check summary 217
shipping bracket 40
shipping foam inserts 40
shut down the Analyzer 115
Sievers Autosampler 34, 89
Sievers DataPro2 Software 34, 35
Single-Point Calibration 149
sipper tube 86
Standard Toolbar 93
standards
 list of required standards 150
Standby 83
stream splitter 30
streaming data via Ethernet 311
Syringe Flush 150

Index

syringe flush 86, 136, 212
system check 218
System Protocols 35
system settings
 backing up 138
 backup 153
 creating master settings 138
 export 153
 loading master settings 138
 resetting 140
 restoring 139
system setup 125

T

TC stream 32
TC/IC Cell Conductivity Autozero 223, 237
terminal block 54, 55, 57, 59
terminal blocks 53
Terminal Wiring 56
terminal wiring 56
thermal mount 201
threshold value 85
Time and date format 123
timed measurement 102
TOC Autozero 154
 enable ICR 156
TOC Autozero, scheduling 154
TOC Removal Online Measurement 100
two-stream inlet 33
two-stream inlet option 33
 description 32
 disable stream 1 or 2 103, 130
 fittings and adjustments 74
 installing 71
 operation 33
 schematic 28
 second stream tubing connection 72
 Stream 1 or 2 select 92
 Stream 2 select 106
 Stream 2 setup 107
 Stream field option 104, 105
 TOC Removal Measurement 100

U

USB 68, 69
USB Host port 69, 70
user defined method 96, 105
User ID 145
UV lamp 30, 127, 201
UV reactor 33

V

value option 84
Verification 35
visual inspection 220

W

warning icon 113, 114
warning or error message 113
warnings
 setting preferences 122
waste outlet 72, 73, 75

NOTES

