

Operating Instructions

Capacitive rod electrode for level detection

VEGACAP 98

Relay (DPDT)



Document ID: 33760



VEGA

Contents

1	About this document	3
1.1	Function	3
1.2	Target group	3
1.3	Symbols used	3
2	For your safety	4
2.1	Authorised personnel	4
2.2	Appropriate use	4
2.3	Warning about incorrect use	4
2.4	General safety instructions	4
2.5	EU conformity	5
2.6	Installation and operation in the USA and Canada	5
2.7	Safety instructions for Ex areas	5
2.8	Environmental instructions	5
3	Product description	6
3.1	Configuration	6
3.2	Principle of operation	7
3.3	Adjustment	7
3.4	Packaging, transport and storage	8
4	Mounting	9
4.1	General instructions	9
4.2	Mounting instructions	10
5	Connecting to power supply	12
5.1	Preparing the connection	12
5.2	Wiring plan, single chamber housing	12
6	Setup	14
6.1	General information	14
6.2	Adjustment elements	14
6.3	Function table	16
7	Maintenance and fault rectification	18
7.1	Maintenance	18
7.2	Rectify faults	18
7.3	Exchanging the electronics module	20
7.4	How to proceed if a repair is necessary	21
8	Dismount	22
8.1	Dismounting steps	22
8.2	Disposal	22
9	Supplement	23
9.1	Technical data	23
9.2	Dimensions	25
9.3	Industrial property rights	26
9.4	Trademark	26

1 About this document

1.1 Function

This operating instructions provides all the information you need for mounting, connection and setup as well as important instructions for maintenance, fault rectification, the exchange of parts and the safety of the user. Please read this information before putting the instrument into operation and keep this manual accessible in the immediate vicinity of the device.

1.2 Target group

This operating instructions manual is directed to trained personnel. The contents of this manual must be made available to the qualified personnel and implemented.

1.3 Symbols used



Document ID

This symbol on the front page of this instruction refers to the Document ID. By entering the Document ID on www.vega.com you will reach the document download.



Information, tip, note

This symbol indicates helpful additional information.



Caution: If this warning is ignored, faults or malfunctions can result.



Warning: If this warning is ignored, injury to persons and/or serious damage to the instrument can result.

Danger: If this warning is ignored, serious injury to persons and/or destruction of the instrument can result.



Ex applications

This symbol indicates special instructions for Ex applications.



SIL applications

This symbol indicates instructions for functional safety which must be taken into account particularly for safety-relevant applications.



List

The dot set in front indicates a list with no implied sequence.



Action

This arrow indicates a single action.



Sequence of actions

Numbers set in front indicate successive steps in a procedure.



Battery disposal

This symbol indicates special information about the disposal of batteries and accumulators.

2 For your safety

2.1 Authorised personnel

All operations described in this documentation must be carried out only by trained, qualified personnel authorised by the plant operator.

During work on and with the device, the required personal protective equipment must always be worn.

2.2 Appropriate use

The VEGACAP 98 is a sensor for point level detection.

You can find detailed information about the area of application in chapter " *Product description*".

Operational reliability is ensured only if the instrument is properly used according to the specifications in the operating instructions manual as well as possible supplementary instructions.

For safety and warranty reasons, any invasive work on the device beyond that described in the operating instructions manual may be carried out only by personnel authorised by the manufacturer. Arbitrary conversions or modifications are explicitly forbidden.

2.3 Warning about incorrect use

Inappropriate or incorrect use of this product can give rise to application-specific hazards, e.g. vessel overflow through incorrect mounting or adjustment. Damage to property and persons or environmental contamination can result. Also, the protective characteristics of the instrument can be impaired.

2.4 General safety instructions

This is a state-of-the-art instrument complying with all prevailing regulations and directives. The instrument must only be operated in a technically flawless and reliable condition. The operator is responsible for the trouble-free operation of the instrument. When measuring aggressive or corrosive media that can cause a dangerous situation if the instrument malfunctions, the operator has to implement suitable measures to make sure the instrument is functioning properly.

The safety instructions in this operating instructions manual, the national installation standards as well as the valid safety regulations and accident prevention rules must be observed by the user.

For safety and warranty reasons, any invasive work on the device beyond that described in the operating instructions manual may be carried out only by personnel authorised by the manufacturer. Arbitrary conversions or modifications are explicitly forbidden. For safety reasons, only the accessory specified by the manufacturer must be used.

To avoid any danger, the safety approval markings and safety tips on the device must also be observed.

2.5 EU conformity

The device fulfils the legal requirements of the applicable EU directives. By affixing the CE marking, we confirm successful testing of the product.

You can find the CE Certificate of Conformity in the download section under "www.vega.com".

2.6 Installation and operation in the USA and Canada

This information is only valid for USA and Canada. Hence the following text is only available in the English language.

Installations in the US shall comply with the relevant requirements of the National Electrical Code (ANSI/NFPA 70).

Installations in Canada shall comply with the relevant requirements of the Canadian Electrical Code.

2.7 Safety instructions for Ex areas

For Ex applications, only devices with corresponding Ex approval may be used. Observe the Ex-specific safety instructions. These are an integral part of the operating instructions and are enclosed with every device with Ex approval.

2.8 Environmental instructions

Protection of the environment is one of our most important duties. That is why we have introduced an environment management system with the goal of continuously improving company environmental protection. The environment management system is certified according to DIN EN ISO 14001.

Please help us fulfil this obligation by observing the environmental instructions in this manual:

- Chapter "*Packaging, transport and storage*"
- Chapter "*Disposal*"

3 Product description

3.1 Configuration

Scope of delivery

The scope of delivery encompasses:

- VEGACAP 98 point level switch

The further scope of delivery encompasses:

- Documentation
 - Operating instructions VEGACAP 98
 - If necessary, further certificates



Information:

Optional instrument features are also described in this operating instructions manual. The respective scope of delivery results from the order specification.

Constituent parts

The VEGACAP 98 consists of the components:

- Process fitting with probe
- Housing with electronics
- Housing lid

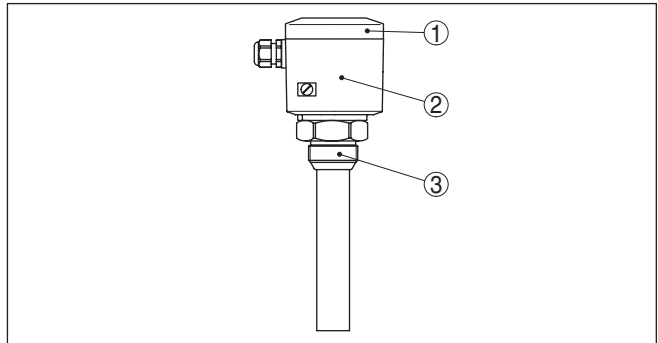

Fig. 1: VEGACAP 98

- 1 Housing lid
- 2 Housing with electronics
- 3 Process fitting

Type label

The type label contains the most important data for identification and use of the instrument:

- Article number
- Serial number
- Technical data
- Article numbers, documentation

With the serial number, you can access the delivery data of the instrument via "www.vega.com", "Search". You can find the serial number on the inside of the instrument as well as on the type label on the outside.

3.2 Principle of operation

Area of application

VEGACAP 98 is an adjustment-free, economic point level sensor for liquids and bulk solids.

It is ideal as overflow or dry run protection system in adhesive, conductive products. The VEGACAP 98 works in liquids from a dielectric constant of 1.5. The process fitting is a thread G1½.

Functional principle

Probe, measured product and vessel wall form an electrical capacitor. The capacitance is influenced by three main factors.

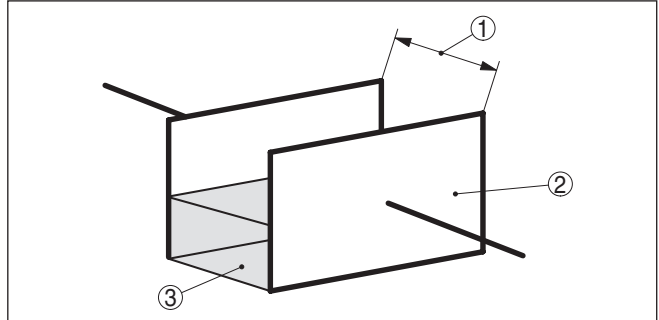

Fig. 2: Functional principle - Plate capacitor

- 1 Distance between the electrode surfaces
- 2 Size of the electrode surfaces
- 3 Type of dielectric between the electrodes

The probe and the vessel wall are the capacitor plates. The measured product is the dielectric. Due to the higher dielectric constant of the product compared to air, the capacitance increases as the probe is gradually covered.

The capacitance change is converted by the electronics module into a switching command.

Voltage supply

VEGACAP 98 is a compact instrument, i.e. it can be operated without external evaluation system. The integrated electronics evaluates the level signal and outputs a switching signal. With this switching signal, a connected device can be operated directly (e.g. a warning system, a pump etc.).

The data for power supply are specified in chapter " *Technical data*".

3.3 Adjustment

The probe can be adapted to the dielectric constant of the product directly on the electronics module.

A switching command can be triggered when the probe is covered or laid bare.

On the electronics module you will find the following display and adjustment elements:

- Control lamp for indication of the switching status
- Potentiometer for switching point adaptation (covered)

- DIL switch for mode adjustment

3.4 Packaging, transport and storage

Packaging

Your instrument was protected by packaging during transport. Its capacity to handle normal loads during transport is assured by a test based on ISO 4180.

The packaging of standard instruments consists of environment-friendly, recyclable cardboard. For special versions, PE foam or PE foil is also used. Dispose of the packaging material via specialised recycling companies.

Transport

Transport must be carried out in due consideration of the notes on the transport packaging. Nonobservance of these instructions can cause damage to the device.

Transport inspection

The delivery must be checked for completeness and possible transit damage immediately at receipt. Ascertained transit damage or concealed defects must be appropriately dealt with.

Storage

Up to the time of installation, the packages must be left closed and stored according to the orientation and storage markings on the outside.

Unless otherwise indicated, the packages must be stored only under the following conditions:

- Not in the open
- Dry and dust free
- Not exposed to corrosive media
- Protected against solar radiation
- Avoiding mechanical shock and vibration

Storage and transport temperature

- Storage and transport temperature see chapter " *Supplement - Technical data - Ambient conditions* "
- Relative humidity 20 ... 85 %

Lifting and carrying

With instrument weights of more than 18 kg (39.68 lbs) suitable and approved equipment must be used for lifting and carrying.

4 Mounting

4.1 General instructions

Process conditions



Note:

For safety reasons, the instrument must only be operated within the permissible process conditions. You can find detailed information on the process conditions in chapter " *Technical data*" of the operating instructions or on the type label.

Hence make sure before mounting that all parts of the instrument exposed to the process are suitable for the existing process conditions.

These are mainly:

- Active measuring component
- Process fitting
- Process seal

Process conditions in particular are:

- Process pressure
- Process temperature
- Chemical properties of the medium
- Abrasion and mechanical influences

Suitability for the ambient conditions

The instrument is suitable for standard and extended ambient conditions acc. to DIN/EN/IEC/ANSI/ISA/UL/CSA 61010-1. It can be used indoors as well as outdoors.

Switching point

In general the level switch can be mounted in any position. The instrument must be mounted in such a way that the probe is at the height of the requested switching point.

Welding work

Before beginning the welding work, remove the electronics module from the sensor. By doing this, you avoid damage to the electronics through inductive coupling.

Ground the probe before welding directly on the rod or cable.

Handling

With threaded versions, the housing must not be used to screw in the instrument! Applying tightening forces on the housing can damage its internal parts.

Use the hexagon for screwing in.

Moisture

Use the recommended cables (see chapter " *Connecting to power supply*") and tighten the cable gland.

You can give your instrument additional protection against moisture penetration by leading the connection cable downward in front of the cable gland. Rain and condensation water can thus drain off. This applies mainly to outdoor mounting as well as installation in areas where high humidity is expected (e.g. through cleaning processes) or on cooled or heated vessels.

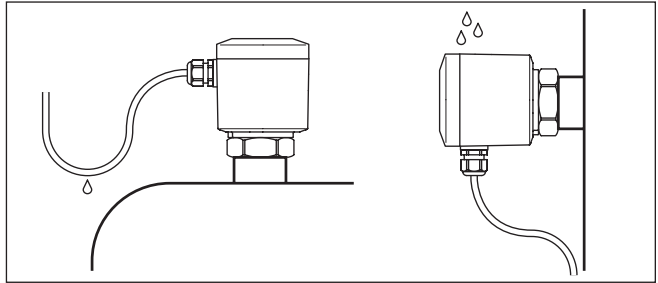

Fig. 3: Measures against moisture ingress

Pressure/Vacuum

The process fitting must be sealed if there is gauge or low pressure in the vessel. Before use, check if the sealing material is resistant against the measured product and the process temperature.

The max. permissible pressure is specified in chapter " *Technical data*" or on the type label of the sensor.

Cable entries - NPT thread Cable glands

Metric threads

In the case of instrument housings with metric thread, the cable glands are screwed in at the factory. They are sealed with plastic plugs as transport protection.

You have to remove these plugs before electrical connection.

NPT thread

In the case of instrument housings with self-sealing NPT threads, it is not possible to have the cable entries screwed in at the factory. The free openings for the cable glands are therefore covered with red dust protection caps as transport protection.

Prior to setup you have to replace these protective caps with approved cable glands or close the openings with suitable blind plugs.

Inflowing medium

4.2 Mounting instructions

If the instrument is mounted in the filling stream, unwanted false measurement signals can be generated. For this reason, mount the instrument at a position in the vessel where no disturbances, e.g. from filling openings, agitators, etc., can occur.

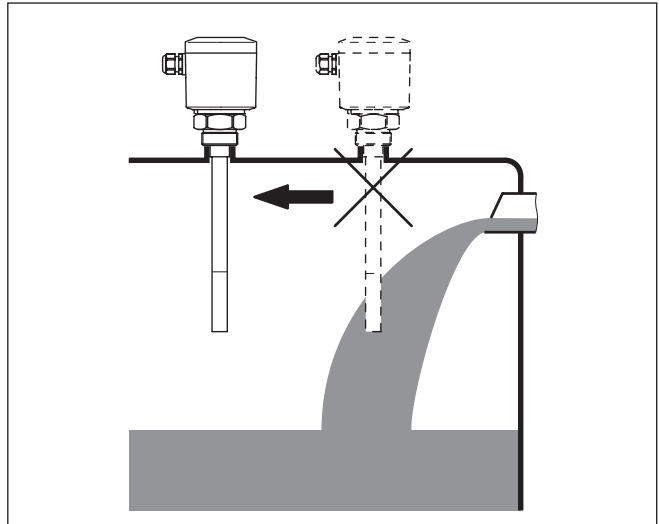

Fig. 4: Inflowing medium

5 Connecting to power supply

5.1 Preparing the connection

Note safety instructions

Always keep in mind the following safety instructions:



Warning:

Connect only in the complete absence of line voltage.

- The electrical connection must only be carried out by trained, qualified personnel authorised by the plant operator.
- Always switch off power supply, before connecting or disconnecting the instrument.

Voltage supply

Connect the voltage supply according to the following connection diagrams. The electronics module CAP E31R is designed in protection class I. To maintain this protection class, it is absolutely necessary that the ground conductor be connected to the internal ground terminal. Take note of the general installation regulations.

The data for power supply are specified in chapter " *Technical data*".

Connection cable

The instrument is connected with standard three-wire cable without shielding. If electromagnetic interference is expected which is above the test values of EN 61326 for industrial areas, shielded cable should be used.

Make sure that the cable used has the required temperature resistance and fire safety for max. occurring ambient temperature

Use cable with round cross-section. A cable outer diameter of 5 ... 9 mm (0.2 ... 0.35 in) ensures the seal effect of the cable gland. If you are using cable with a different diameter or cross-section, exchange the seal or use a suitable cable gland.



Note:

When placing the housing cover, make sure that the inspection glass is above the signal lamp of the electronics module.

5.2 Wiring plan, single chamber housing

Wiring plan

We recommend connecting VEGACAP 98 in such a way that the switching circuit is open when there is a level signal, line break or failure (safe state).

The relays are always shown in non-operative condition.

The two relays (DPDT) work synchronously. Hence it is possible to control also e.g. a horn and a magnet valve.

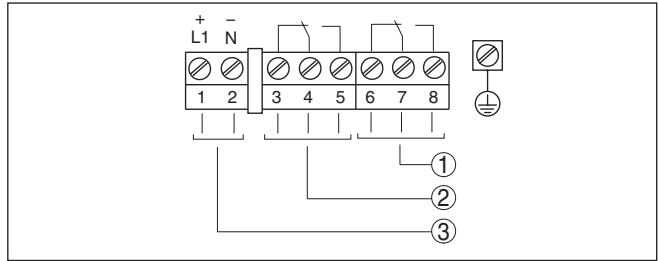

Fig. 5: Wiring plan

- 1 Relay output
- 2 Relay output
- 3 Voltage supply

Connection to a PLC

If inductive loads or stronger currents are switched through, the gold plating on the relay contact surface will be permanently damaged. The contact is then no longer suitable for switching low-voltage circuits.

Inductive loads also result from the connection to a PLC input or output and/or in combination with long cables. It is imperative that you take measures to extinguish sparks to protect the relay contact (e.g. Z diode) or use an electronic version with transistor output.

6 Setup

6.1 General information

The figures in brackets refer to the following illustrations.

Function/Configuration On the electronics module you will find the following display and adjustment elements:

- Potentiometer for switching point adaptation
- DIL switch for mode adjustment - A/B
- Control lamp



Note:

As a rule, always set the mode with the mode switch (5) before starting setup VEGACAP 98. The switching output will change if you set the mode switch (5) afterwards. This could possibly trigger other connected instruments or devices.

6.2 Adjustment elements

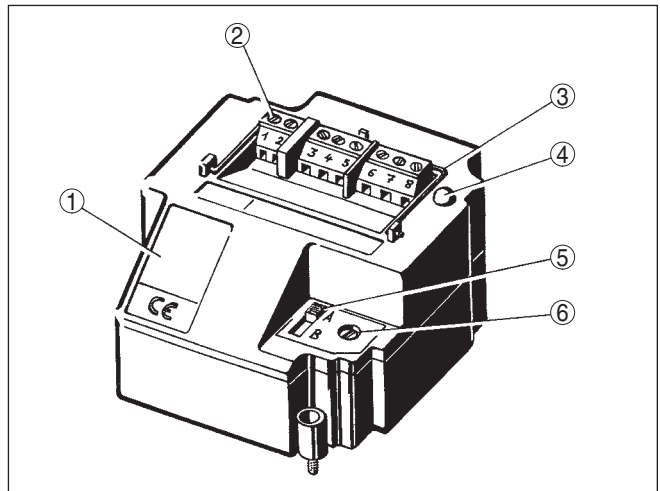

Fig. 6: Oscillator with relay output

- 1 Type label
- 2 Connection terminals
- 3 Tensile proving ring
- 4 Control lamp
- 5 DIL switch for mode adjustment
- 6 Potentiometer for switching point adaptation

The switching status of the electronics can be checked with closed housing (only plastic housing), see "Function table".



Note:

When placing the housing cover, make sure that the inspection glass is above the signal lamp (LED) of the electronics module.

To adjust VEGACAP 98, loosen first of all the four screws on the upper side of the instrument with a screwdriver and remove the housing cover.

Switching point adaptation (6)

You can adapt the switching point to the solid with the potentiometer. The electronics is adjustment free and an adaption is only necessary in exceptions. See "*Exceptions*".

Mode adjustment (5)

With the mode switch you can change the switching condition of the relay. You can set the required mode (A - max. detection or overflow protection, B - min. detection or dry run protection).

We recommend connecting according to the idle current principle (relay contact deenergizes when the switching point is reached), because the relay always takes on the same (safe) state if a failure is detected or in case of mains failure.

Signal lamp (4)

Control lamp for indication of the switching status.

- Control lamp on = Relay deenergised

Switching point adjustment

The measuring system is immediately ready for operation.

The switching point must no longer be set with VEGACAP 98.

The probe has an active tip and a screen segment. Thanks to the screen segment, the so called standing capacitance, caused by the vessel after installation of the probe, is mainly compensated.

As a default setting, the electronics module is adjusted to the basic capacitance of the probe. The relay output switching when the active tip is covered (active tip: 90 mm / 3.5 in) of the electrode.

Changing dielectric values of the products, such as e.g. caused in mixing vessels are no problem for the switching accuracy within the active pin. The selection of the electrode length is hence very important because the length of the electrode determines the switching point. This switching point cannot be shifted on the electrode.

Exceptions

In exceptions, e.g. in pipelines or if the probe is mounted very close to the vessel wall, it can happen at the probe signals already overflowing (covering) in uncovered condition.

In this case, the switching point must be re-adjusted.

For adjustment, the vessel must not be filled and the switching point adjustment is also possible in dismounted condition.

A fresh adjustment is necessary in the following cases:

- in narrow space installation conditions with high standing capacitance (e.g. in tubes etc.)
- after exchange of the electronics module

Fresh adjustment

Proceed as follows for a fresh adjustment:

1. Make sure that the probe is uncovered.
2. Pierce the cover of the potentiometer (6) with a screwdriver.

3. Turn the below potentiometer (6) first of all anticlockwise (max. 20 turns) until the control lamp signals "covered".
Mode A (overflow protection) = control lamp lights
Mode B (dry run protection) = control lamp extinguishes
If this condition is already reached, you can continue with the next step.
4. Turn the potentiometer (6) very slowly (due to the damping) clockwise until the control lamp signals "uncovered".
Mode A (overflow protection) = control lamp extinguishes
Mode B (dry run protection) = control lamp lights
5. Turn the potentiometer (6) clockwise according to the following table.
6. The probe is now ready for operation.

Sensitivity

	Standard	very sensitive
additional turns	Dielectric constant >2 = 2 turns	Dielectric constant >1.5 = 1 turn

Tab. 1: Number of additional turns for the potentiometer (6)



Note:

With the measurement of products with very low dielectric values, the number of turns can be reduced up to 1 according to the table.

This setting is too sensitive with conductive, adhesive products.















Note:

When placing the housing cover, make sure that the inspection glass is above the signal lamp of the electronics module.

6.3 Function table

The following table provides an overview of the switching conditions depending on the set mode and the level.

	Level	Switching status	Control lamp
Mode A Overflow protection		 Relay energized	
Mode A Overflow protection		 Relay deenergized	

	Level	Switching status	Control lamp
Mode B Dry run protection		 Relay energized	○
Mode B Dry run protection		 Relay deenergized	
Failure of the supply voltage (mode A/B)	any	 Relay deenergized	○

7 Maintenance and fault rectification

7.1 Maintenance

Maintenance

If the device is used properly, no special maintenance is required in normal operation.

Cleaning

The cleaning helps that the type label and markings on the instrument are visible.

Take note of the following:

- Use only cleaning agents which do not corrode the housings, type label and seals
- Use only cleaning methods corresponding to the housing protection rating

7.2 Rectify faults

Reaction when malfunction occurs

The operator of the system is responsible for taking suitable measures to rectify faults.

Fault rectification

The first measure to take is to check the output signal. In many cases, the causes can be determined this way and the faults quickly rectified.

24 hour service hotline

Should these measures not be successful, please call in urgent cases the VEGA service hotline under the phone no. **+49 1805 858550**.

The hotline is manned 7 days a week round-the-clock. Since we offer this service worldwide, the support is only available in the English language. The service is free, only standard call charges are incurred.

Checking the switching signal

Error	Cause	Rectification
<ul style="list-style-type: none"> ● The instrument signals covered without being covered by the medium ● The instrument signals uncovered while covered with the medium 	Wrong mode selected	Set the correct mode on the mode switch (A - overflow protection, B - dry run protection). Wiring should be carried out according to the idle current principle.
	Operating voltage too low	Check operating voltage
	Shortcircuit in the probe, e.g. because of moisture in the housing	Remove the electronics module. Check the resistance between the marked plug connections. See the following instructions.
	Electronics defective	<p>Press the mode switch (A/B). If the instrument then changes the mode, the instrument may be mechanically damaged. Should the switching function in the correct mode still be faulty, return the probe for repair.</p> <p>Push the mode switch. If the probe then does not change the mode, the electronics module may be defective. Exchange the electronics module.</p>

Check the resistance in the probe

Remove the electronics module. Check the resistance between the two plug connections.

There must no longer be a connection (high impedance). If there is still a connection, exchange the instrument or return it for repair

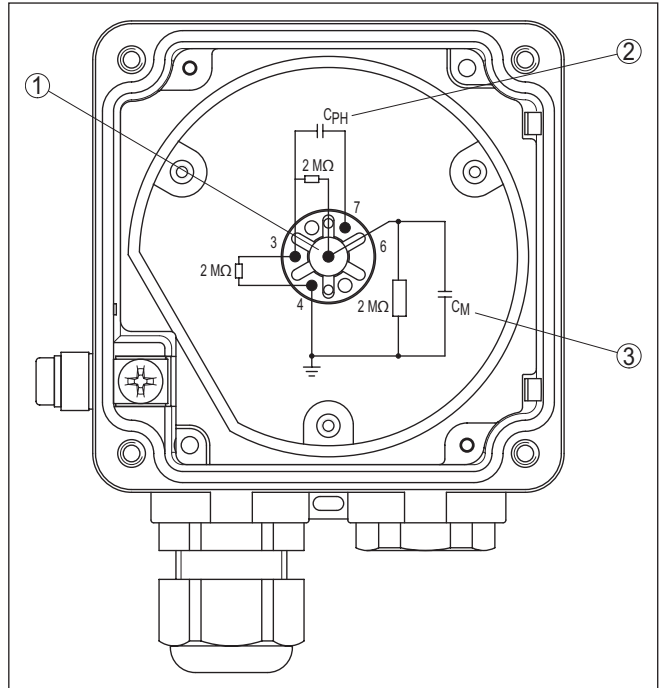

Fig. 7: Check the resistance in the probe

- 1 Contact 1 (middle pin)
- 2 Variable capacitor (phase)
- 3 Capacitor

Measure the resistance values between the following contacts with an ohmmeter (range $M\Omega$).

Contact 4 against contact 1 (middle pin)

The resistor must be $2 M\Omega$.

If the resistor is lower, this means moisture in the housing or a fault in the electrode insulation. A possible reason could be also a non-insulated electrode which is used in a conductive (humid) medium.

If the resistor is higher or if the connection is interrupted, the reason is mostly a contact error in the adapter plate or a defective resistor due to strong electrostatic arking.

In both cases, the probe must be repaired in our premises.

Contact 4 against vessel

The electrical connection between contact 4 and metal vessel (not the mounting boss or probe flange) should be good. Measure the resistance value between contact 4 and vessel with an ohmmeter (range very small).

- Shortcircuit (0 ... 3Ω) - optimum connection
- Resistor $> 3 \Omega$ - bad connection

If the resistance value is $> 3 \Omega$, this can be due to corrosion on the thread or flange or the thread was covered e.g. with teflon tape.

Check the connection to the vessel. If there is no connection, you can connect a cable from the outer ground terminal to the vessel.

Keep in mind that coated flanges must always be connected via the ground terminal to the vessel.

Contact 7 against contact 1 (middle pin)

The resistor must be infinite ($> 10 \text{ M}\Omega$)

If the resistor is lower, then moisture can be penetrated or the compensation capacitor or variable capacitor (phase) is defective.

Contact 3 (screen) against contact 4

The resistor must be $2 \text{ M}\Omega$.

In case of lower values, the electrode insulation is defective or moisture is penetrated into the housing.

In case of higher values, there is a contacting error in the adapter plate or the resistor is defective.

No fault

If you cannot find a fault in the probe, then exchange the electronics module by a similar replacement electronics (if available).

If the fault is eliminated after inserting the new electronics module, then you have to carry out a fresh adjustment with the new electronics module because electronics modules have certain manufacturing tolerances.

If the fault still exists or if no replacement electronics module is available, then you have to return the probe for repair.

Contact 3 (screen) against contact 1 (middle pin)

The resistor must be $2 \text{ M}\Omega$.

In case of lower values, the electrode insulation is defective or moisture is penetrated into the housing.

In case of higher values, there is a contacting error in the adapter plate or the resistor is defective.

Reaction after fault rectification

Depending on the reason for the fault and the measures taken, the steps described in chapter "Set up" may have to be carried out again.

7.3 Exchanging the electronics module

If it is necessary to exchange the electronics module, you should use an electronics module type CAP E31R

Proceed as follows:

1. Switch off power supply
2. Loosen the four screws of the housing cover with a Phillips screwdriver.
3. Remove the housing cover
4. Loosen the screws of the terminals with a Allen wrench.
5. Pull the connection cables out of the terminals.

6. Loosen the two screws with a Torx screwdriver.
 7. Open the tensile ring on the old electronics module and pull out the old electronics module.
 8. Compare the new electronics module with the old one. The type label of the electronics module must correspond to that of the old electronics module.
 9. Insert the new electronics module.
 10. Screw in and tighten the two screws with a Torx screwdriver.
 11. Lead the connection cable through the cable gland.
 12. Insert the wire ends into the open terminals according to the wiring plan and tighten them.
 13. Check the hold of the wires in the terminals by lightly pulling on them.
 14. Tighten cable gland and check on tightness. The seal ring must completely encircle the cable.
 15. Carry out a fresh adjustment. See chapter "*Set up, new adjustment*".
 16. Screw the housing lid back on
- The electronics exchange is now finished.

7.4 How to proceed if a repair is necessary

You can find an instrument return form as well as detailed information about the procedure in the download area of our homepage: www.vega.com.

By doing this you help us carry out the repair quickly and without having to call back for needed information.

If a repair is necessary, please proceed as follows:

- Print and fill out one form per instrument
- Clean the instrument and pack it damage-proof
- Attach the completed form and, if need be, also a safety data sheet outside on the packaging
- Please contact the agency serving you to get the address for the return shipment. You can find the agency on our home page www.vega.com.

8 Dismount

8.1 Dismounting steps

**Warning:**

Before dismantling, be aware of dangerous process conditions such as e.g. pressure in the vessel, high temperatures, corrosive or toxic products etc.

Take note of chapters "*Mounting*" and "*Connecting to voltage supply*" and carry out the listed steps in reverse order.

8.2 Disposal

The instrument consists of materials which can be recycled by specialised recycling companies. We use recyclable materials and have designed the electronics to be easily separable.

WEEE directive

The instrument does not fall in the scope of the EU WEEE directive. Article 2 of this Directive exempts electrical and electronic equipment from this requirement if it is part of another instrument that does not fall in the scope of the Directive. These include stationary industrial plants.

Pass the instrument directly on to a specialised recycling company and do not use the municipal collecting points.

If you have no way to dispose of the old instrument properly, please contact us concerning return and disposal.

9 Supplement

9.1 Technical data

General data

Material 316L corresponds to 1.4404 or 1.4435

Materials, wetted parts

- Process fitting - thread PP
- Process seal Klingersil C-4400
- insulation (fully insulated) PP

Materials, non-wetted parts

- Housing Plastic PBT (polyester), Alu die-casting powder-coated
- Seal between housing and housing lid Silicone
- Ground terminal 316L
- Cable gland PA, stainless steel, brass
- Sealing, cable gland NBR
- Blind plug, cable gland PA

Process fittings

- Pipe thread, cylindrical (DIN 3852-A) G1½

Weight

- Instrument weight 0.8 ... 4 kg (0.18 ... 8.82 lbs)
- Rod weight ø 33 mm (1.3 in) approx. 560 g/m (6 oz/ft)

Sensor length (L) 150 ... 2000 mm (5.91 ... 78.74 ft)

Active tip (LA) 90 mm (3.898 in)

Max. lateral load 5 Nm (3.7 lbf ft)

Max. torque (process fitting - thread) 30 Nm (22 lbf ft)

Torque for NPT cable glands and Conduit tubes

- Plastic housing max. 10 Nm (7.376 lbf ft)
- Aluminium housing max. 50 Nm (36.88 lbf ft)

Measuring frequency 430 kHz

Output variable

Output Relay output (DPDT), 2 floating spdts

Switching voltage

- Min. 10 mV
- Max. 253 V AC, 253 V DC

With circuits > 150 V AC/DC, the relay contacts must be in the same circuit.

Switching current

- Min. 10 µA
- Max. 3 A AC, 1 A DC

Breaking capacity	
– Min.	50 mW
– Max.	750 VA AC, 54 W DC
	If inductive loads or stronger currents are switched through, the gold plating on the relay contact surface will be permanently damaged. The contact is then no longer suitable for switching low-level signal circuits.
Potential separation	> 500 V DC
Contact material (relay contacts)	AgNi (Au plated) or AgSnO (Au plated)
Modes (switchable)	A (overflow protection)/B (dry run protection)
Switching delay	
– When immersed	0.7 s
– When laid bare	0.7 s
– In the event of a fault	1 s

Ambient conditions

Ambient temperature on the housing	-40 ... +80 °C (-40 ... +176 °F)
Storage and transport temperature	-40 ... +80 °C (-40 ... +176 °F)

Process conditions

Process pressure	unpressurized
Process temperature VEGACAP 98 of PP	-30 ... +80 °C (-22 ... +176 °F)
Dielectric constant	≥ 1.5

Electromechanical data

Options of the cable entry	
– Cable entry	M20 x 1.5, ½ NPT
– Cable gland	M20 x 1.5, ½ NPT
– Blind plug	M20 x 1.5, ½ NPT
– Closing cap	½ NPT
Screw terminals	for wire cross-section up to 1.5 mm ² (AWG 16)

Adjustment elements

Mode switch	
– A	Min. detection or dry run protection
– B	Max. detection or overflow protection
Potentiometer	Switching point adaptation

Voltage supply

Operating voltage	20 ... 253 V AC, 50/60 Hz, 20 ... 72 V DC (at U >60 V DC, the ambient temperature can be max. 50 °C/122 °F)
Power consumption	1 ... 9 VA (AC), approximately 1.5 W (DC)

Electrical protective measures

Protection rating	IP66/IP67 (NEMA Type 4X)
Altitude above sea level	up to 5000 m (16404 ft)
Overvoltage category	
– up to 2000 m (6562 ft)	III
– up to 5000 m (16404 ft)	II
Protection class	I

Approvals

Instruments with approvals can have different technical specifications depending on the version.

For that reason the associated approval documents of these instruments have to be carefully noted. They are part of the delivery or can be downloaded by entering the serial number of your instrument into the search field under www.vega.com as well as in the general download area.

9.2 Dimensions

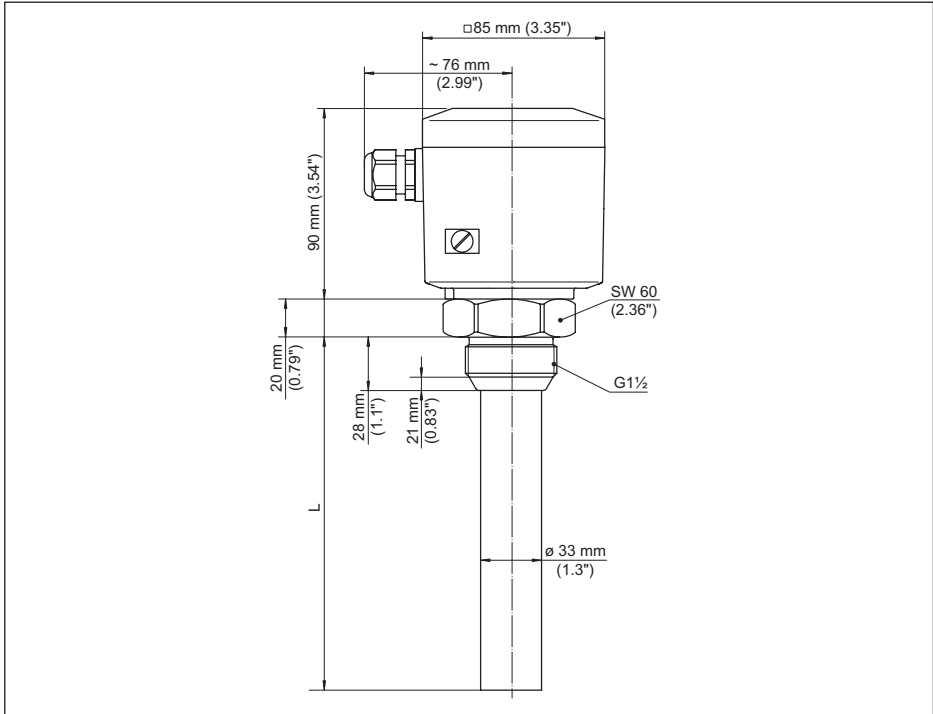

Fig. 8: VEGACAP 98, threaded version G1½ A (ISO 228 T1)

L Sensor length, see chapter "Technical data"

9.3 Industrial property rights

VEGA product lines are global protected by industrial property rights. Further information see www.vega.com.

VEGA Produktfamilien sind weltweit geschützt durch gewerbliche Schutzrechte.

Nähere Informationen unter www.vega.com.

Les lignes de produits VEGA sont globalement protégées par des droits de propriété intellectuelle. Pour plus d'informations, on pourra se référer au site www.vega.com.

VEGA líneas de productos están protegidas por los derechos en el campo de la propiedad industrial. Para mayor información revise la pagina web www.vega.com.

Линии продукции фирмы ВЕГА защищаются по всему миру правами на интеллектуальную собственность. Дальнейшую информацию смотрите на сайте www.vega.com.

VEGA系列产品在全球享有知识产权保护。

进一步信息请参见网站www.vega.com。

9.4 Trademark

All the brands as well as trade and company names used are property of their lawful proprietor/originator.



Printing date:

VEGA

All statements concerning scope of delivery, application, practical use and operating conditions of the sensors and processing systems correspond to the information available at the time of printing.

Subject to change without prior notice

© VEGA Grieshaber KG, Schiltach/Germany 2021



33760-EN-210310

VEGA Grieshaber KG
Am Hohenstein 113
77761 Schiltach
Germany

Phone +49 7836 50-0
E-mail: info.de@vega.com
www.vega.com