

Operating Instructions

Interface adapter between PC and communication-capable VEGA instruments

VEGACONNECT 4 with connection box

Interface converter USB - HART/I²C



Document ID: 32628



VEGA

Contents

- 1 About this document**
 - 1.1 Function 3
 - 1.2 Target group 3
 - 1.3 Symbols used..... 3
- 2 For your safety**
 - 2.1 Authorised personnel 4
 - 2.2 Appropriate use..... 4
 - 2.3 Warning about incorrect use..... 4
 - 2.4 General safety instructions 4
 - 2.5 Safety label on the instrument 5
 - 2.6 EU conformity..... 5
 - 2.7 Safety instructions for Ex areas 5
 - 2.8 Environmental instructions 5
- 3 Product description**
 - 3.1 Configuration..... 6
 - 3.2 Principle of operation..... 7
 - 3.3 Adjustment 8
 - 3.4 Packaging, transport and storage..... 8
- 4 Connection**
 - 4.1 Connection to the PC 9
 - 4.2 Connection of the sensor/signal conditioning instrument 10
- 5 Connection examples**
 - 5.1 Connection via I²C interface 12
 - 5.2 Connection via HART 13
- 6 Setup**
 - 6.1 Adjustment 16
- 7 Maintenance and fault rectification**
 - 7.1 Maintenance 17
 - 7.2 How to proceed if a repair is necessary 17
- 8 Recycling and disposal**
 - 8.1 Disposal 18
- 9 Supplement**
 - 9.1 Technical data 19
 - 9.2 Dimensions 20
 - 9.3 Industrial property rights..... 21
 - 9.4 Trademark 21



Information:

The VEGACONNECT 4 can be reordered in case of damage or loss under the order code CONNECT.CXX4.

Editing status: 2017-01-26

1 About this document

1.1 Function

This operating instructions manual provides all the information you need for mounting, connection and setup as well as important instructions for maintenance and fault rectification. Please read this information before putting the instrument into operation and keep this manual accessible in the immediate vicinity of the device.

1.2 Target group

This operating instructions manual is directed to trained specialist personnel. The contents of this manual should be made available to these personnel and put into practice by them.

1.3 Symbols used



Information, tip, note

This symbol indicates helpful additional information.



Caution: If this warning is ignored, faults or malfunctions can result.



Warning: If this warning is ignored, injury to persons and/or serious damage to the instrument can result.



Danger: If this warning is ignored, serious injury to persons and/or destruction of the instrument can result.



Ex applications

This symbol indicates special instructions for Ex applications.



SIL applications

This symbol indicates instructions for functional safety which must be taken into account particularly for safety-relevant applications.



List

The dot set in front indicates a list with no implied sequence.



Action

This arrow indicates a single action.



Sequence of actions

Numbers set in front indicate successive steps in a procedure.



Battery disposal

This symbol indicates special information about the disposal of batteries and accumulators.

2 For your safety

2.1 Authorised personnel

All operations described in this operating instructions manual must be carried out only by trained specialist personnel authorised by the plant operator.

During work on and with the device the required personal protective equipment must always be worn.

2.2 Appropriate use

The instrument is an interface converter for connecting a Windows PC to communication-capable sensors.

You can find detailed information about the area of application in chapter "*Product description*".

Operational reliability is ensured only if the instrument is properly used according to the specifications in the operating instructions manual as well as possible supplementary instructions.

For safety and warranty reasons, any invasive work on the device beyond that described in the operating instructions manual may be carried out only by personnel authorised by the manufacturer. Arbitrary conversions or modifications are explicitly forbidden.

2.3 Warning about incorrect use

Inappropriate or incorrect use of the instrument can give rise to application-specific hazards, e.g. vessel overflow or damage to system components through incorrect mounting or adjustment.

2.4 General safety instructions

This is a state-of-the-art instrument complying with all prevailing regulations and guidelines. The instrument must only be operated in a technically flawless and reliable condition. The operator is responsible for the trouble-free operation of the instrument.

During the entire duration of use, the user is obliged to determine the compliance of the necessary occupational safety measures with the current valid rules and regulations and also take note of new regulations.

The safety instructions in this operating instructions manual, the national installation standards as well as the valid safety regulations and accident prevention rules must be observed by the user.

For safety and warranty reasons, any invasive work on the device beyond that described in the operating instructions manual may be carried out only by personnel authorised by the manufacturer. Arbitrary conversions or modifications are explicitly forbidden.

The safety approval markings and safety tips on the device must also be observed.

2.5 Safety label on the instrument

The safety approval markings and safety tips on the device must be observed.

2.6 EU conformity

The device fulfils the legal requirements of the applicable EU guidelines. By affixing the CE marking, we confirm successful testing of the product.

You can find the EU conformity declaration on our website under www.vega.com/downloads.

2.7 Safety instructions for Ex areas

Please note the Ex-specific safety information for installation and operation in Ex areas. These safety instructions are part of the operating instructions manual and come with the Ex-approved instruments.

2.8 Environmental instructions

Protection of the environment is one of our most important duties. That is why we have introduced an environment management system with the goal of continuously improving company environmental protection. The environment management system is certified according to DIN EN ISO 14001.

Please help us fulfil this obligation by observing the environmental instructions in this manual:

- Chapter "*Packaging, transport and storage*"
- Chapter "*Disposal*"

3 Product description

3.1 Configuration

Scope of delivery

The scope of delivery encompasses:

- VEGACONNECT 4 interface converter
- Connection box with two connection cables
- USB cable
- HART resistance
- 2 x connection terminals
- Magnetic pen
- Bluetooth USB adapter (optional)
- Documentation
 - This operating instructions manual
 - Ex-specific "*Safety instructions*" (with Ex versions)
 - If necessary, further certificates

Constituent parts

VEGACONNECT consists of the following components:

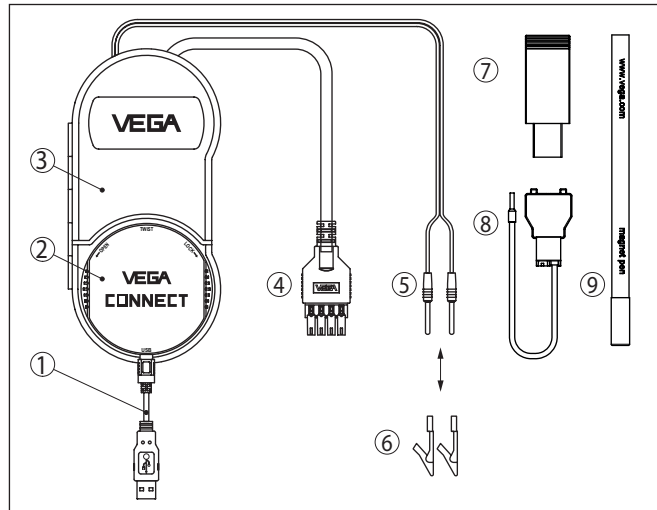

Fig. 1: Configuration VEGACONNECT

- 1 USB cable
- 2 VEGACONNECT 4
- 3 Connection box with storage space
- 4 I²C bus cable
- 5 HART cable with 2 mm pins
- 6 2 x terminals for cable with 2 mm pins
- 7 Bluetooth USB adapter (optional)
- 8 HART resistance
- 9 Magnetic pen

Type label

The type label contains the serial number of the instrument. With it you can find the following instrument data on our homepage:

- Product code (HTML)

- Delivery date (HTML)
- Order-specific instrument features (HTML)
- Operating instructions at the time of shipment (PDF)

Go to "www.vega.com", "*VEGA Tools*" and "*Instrument search*". Enter the serial number.

Alternatively, you can access the data via your smartphone/tablet:

- Download the app "*VEGA Tools*" from the "*Apple App Store*" or the "*Google Play Store*"
- Scan the Data Matrix code on the type label of the instrument or
- Enter the serial number manually in the app

3.2 Principle of operation

Application area

VEGACONNECT 4 is an interface converter for connection of communication-capable VEGA instruments to the USB interface of a Windows PC. It can also be used as a universal HART modem for sensors from other manufacturers. An adjustment software such as PACTware with VEGA DTMs is required for parameter adjustment of these instruments.

VEGACONNECT 4 can be connected to the following VEGA instruments. All currently available electronics versions are supported (HART, Profibus PA, Foundation Fieldbus). When instruments from the plics® series are used, VEGACONNECT 4 can be inserted directly into the respective instrument.

- VEGAPULS radar sensors
- Guided radar VEGAFLEX
- VEGASON ultrasonic sensors
- Pressure transmitter VEGABAR/VEGAWELL/VEGADIF
- Capacitive electrodes VEGACAL
- Radiation-based sensors PROTRAC
- VEGADIS indicating instruments
- Signal conditioning instruments VEGAMET/VEGASCAN

Connection cable, adapter and terminals for connection to the different instrument series are attached to all VEGACONNECT 4. These adapters can be kept in the storage space of the connection box.

Bluetooth USB adapter

The Bluetooth USB adapter enables the wireless adjustment of VEGA sensors with a Windows PC. For this, a PLICSCOM with Bluetooth option integrated in the sensor or a sensor with integrated Bluetooth function are required. In this case, the VEGACONNECT is not used, here the box is only a preserving possibility for the Bluetooth USB adapter. You can find further information of this application in the operating instruction of PLICSCOM or the sensor with integrated Bluetooth function. Depending on the version ordered, the Bluetooth USB adapter is not part of each box.

Magnetic pen

The magnet pen enables the adjustment of the PLICSCOM buttons with closed housing lid with inspection window. In this case, the VEGACONNECT is not used, here the box is only a preserving

possibility for the magnet pen. You can find further information of this application in the operating instruction of PLICSCOM.

Functional principle

The interface converter is connected via the USB interface to a PC. It converts signals and protocols of the USB interface into the appropriate signal/protocol of the connected instrument.

Voltage supply

The voltage supply is provided via the USB interface of the PC.

Detailed information about the power supply can be found in chapter "Technical data".

3.3 Adjustment

The adjustment is carried out via a Windows PC with a parameter adjustment software such as PACTware with respective DTM. There are no adjustment elements on the instrument itself.

3.4 Packaging, transport and storage

Packaging

Your instrument was protected by packaging during transport. Its capacity to handle normal loads during transport is assured by a test based on ISO 4180.

The packaging of standard instruments consists of environment-friendly, recyclable cardboard. For special versions, PE foam or PE foil is also used. Dispose of the packaging material via specialised recycling companies.

Transport

Transport must be carried out in due consideration of the notes on the transport packaging. Nonobservance of these instructions can cause damage to the device.

Transport inspection

The delivery must be checked for completeness and possible transit damage immediately at receipt. Ascertained transit damage or concealed defects must be appropriately dealt with.

Storage

Up to the time of installation, the packages must be left closed and stored according to the orientation and storage markings on the outside.

Unless otherwise indicated, the packages must be stored only under the following conditions:

- Not in the open
- Dry and dust free
- Not exposed to corrosive media
- Protected against solar radiation
- Avoiding mechanical shock and vibration

Storage and transport temperature

- Storage and transport temperature see chapter "Supplement - Technical data - Ambient conditions"
- Relative humidity 20 ... 85 %

4 Connection

4.1 Connection to the PC

Connection



Note:

First of all you should install the driver before connecting VEGACONNECT 4 to the PC.

An USB interface (1.1/2.0/3.0) is compulsory for connection of VEGACONNECT 4 to a Windows PC. The connection is provided with the supplied USB cable. Voltage supply of VEGACONNECT 4 is provided via the USB interface.



If the supplied USB cable is replaced by another one, make sure that the insulation thickness of the cable is over 0.65 mm.

Driver

To operate VEGACONNECT 4, a suitable Windows driver is required which is included on the DVD "*DTM Collection*". As an alternative, the software is also available free-of-charge from our homepage. You should always use the latest version to ensure the support of all instrument functions. The system requirements for operation correspond to those of the "*DTM Collection*" or of PACTware.

When installing the driver package "*VEGA-DTM for Communication*", the suitable instrument driver is installed automatically. When connecting VEGACONNECT 4, the driver installation is finished automatically and is ready for operation without a restart.

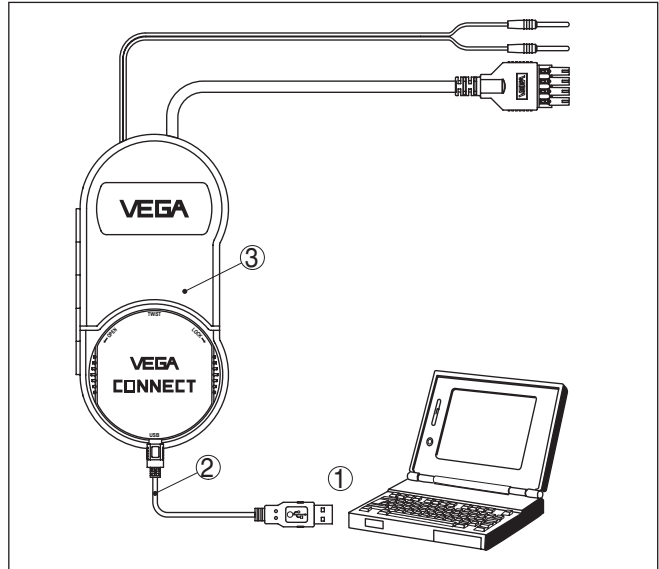

Fig. 2: Electrical connection

- 1 USB connection of the PC
- 2 USB connection cable (in the scope of delivery)
- 3 VEGACONNECT 4 with connection box

4.2 Connection of the sensor/signal conditioning instrument

VEGACONNECT 4 can be connected to virtually all communication-capable VEGA instruments. With instruments of the plics® series it can be mounted directly into the sensor. In this case, you can remove VEGACONNECT 4 out of the connection box and insert it into the plics® device instead of the indicating and adjustment module.

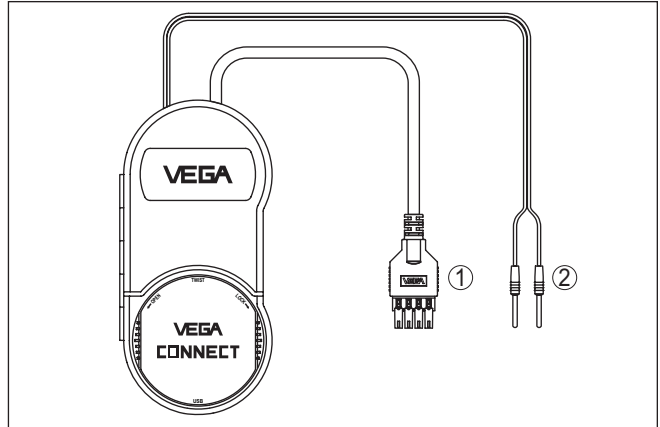

Fig. 3: Connection possibilities

- 1 Communication via I²C protocol
- 2 Communication via HART protocol

Communication via I²C protocol

- Use of VEGACONNECT 4 in all plics® sensors through direct installation (see connection examples)
- For connection to the I²C (Com.) interface of older plics® sensors, connection 1

Communication via HART protocol

- For connection to the 4 ... 20 mA cable (the supplied HART resistor will be required depending on voltage supply/processing), connection 2



In hazardous Ex areas, the HART or I²C cable of VEGACONNECT 4 can be connected to an Ex approved sensor. VEGACONNECT 4 and the PC must not be located in Ex area.

Connection via I²C bus

VEGACONNECT 4 can be connected to the I²C bus interface of the following sensors.

- all sensors of plics® series
- VEGACAP from software version 1.10
- VEGADIS 81/82

**Note:**

The connection of Profibus PA or Foundation Fieldbus instruments is always carried out via the I²C interface on the sensor. A direct connection of VEGACONNECT 4 on the Fieldbus is not possible.

Connection via HART

The connection via the sensor cable can be carried out on any HART sensor. Depending on the processing system, an additional HART resistor is required (see "*Connection examples - Connection via HART*").

5 Connection examples

5.1 Connection via I²C interface



In hazardous Ex areas, the HART or I²C cable of VEGACONNECT 4 can be connected to an Ex approved sensor. VEGACONNECT 4 and the PC must not be located in Ex area.

Installation in plics[®] series

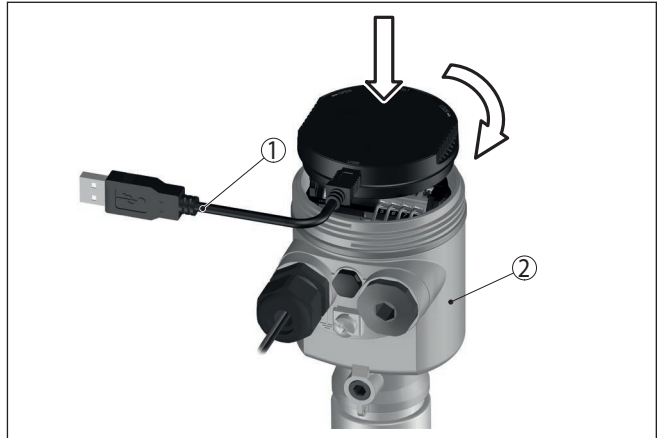

Fig. 4: Installation and connection in plics[®] device

- 1 USB cable
- 2 plics[®] device

External connection plics[®] series

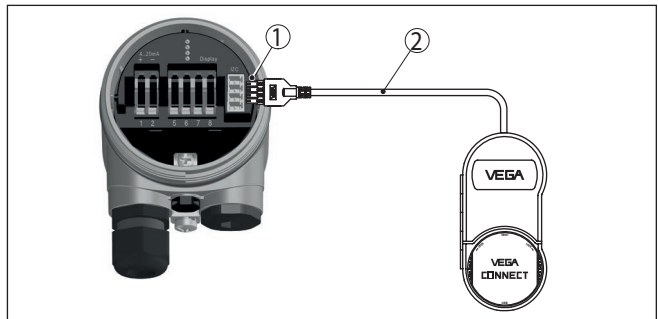

Fig. 5: Connection plics[®] series via I²C interface

- 1 I²C bus (Com.) interface
- 2 I²C connection cable

VEGAMET 624/625,
VEGASCAN 693

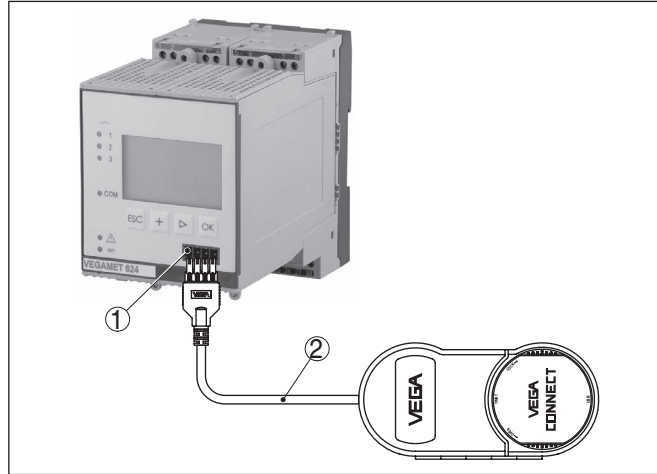

Fig. 6: Connection VEGAMET/VEGASCAN via I²C interface

- 1 I²C bus (Com.) interface
- 2 I²C connection cable



Note:

Communication with the sensor is carried out with VEGAMET 624/625 and VEGASCAN 693 also via the front I²C interface of the signal conditioning instrument. The connection of VEGACONNECT 4 directly to the 4 ... 20 mA sensor cable is not possible.

5.2 Connection via HART

HART communication

If the resistance of the connected processing system is less than 230 Ω, the digital adjustment signal is extremely damped or short-circuited. Digital communication with the PC is then no longer possible. With low impedance processing systems, a resistance of at least 230 Ω must be integrated into the 4 ... 20 mA connection cable. The connection of VEGACONNECT 4 can be either carried out in parallel to the sensor or via the resistor.



Note:

When connecting to a VEGAMET 381, VEGADIS 371 or VEGATRENN 141/142/151/152 there is no additional HART resistor required. These instruments have also connection sockets for direct connection of the 2 mm pins.

When using VEGAMET 624/625, VEGASCAN 693 signal conditioning instruments, the connection cannot be carried out via the sensor cable. The parameter adjustment of the signal conditioning instrument as well as of the sensor can be carried out via the I²C connection sockets.

HART sensor with VEGAMET 381

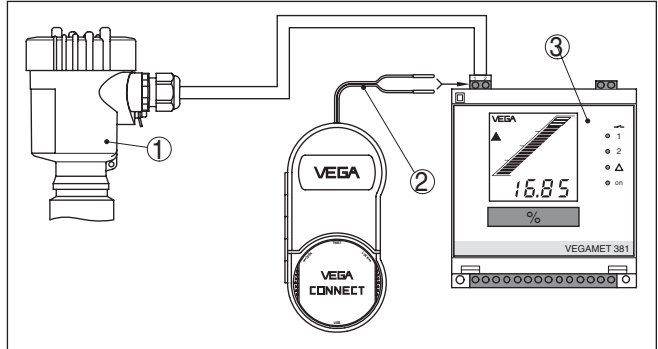

Fig. 7: Connection plics® series to a VEGAMET

- 1 HART sensor
- 2 Connection cable with 2 mm pins
- 3 VEGAMET 381 or VEGADIS 371

HART sensor with VEGATRENN

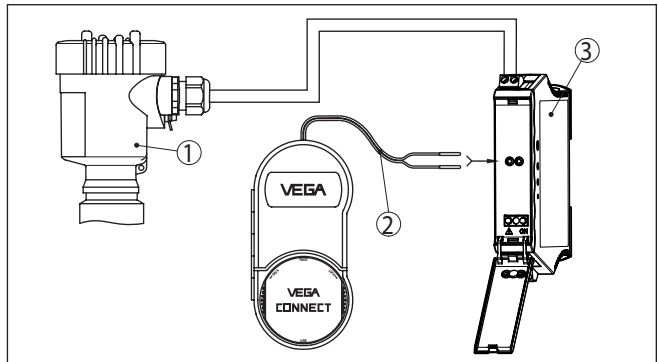

Fig. 8: Connection plics® series via HART to a VEGATRENN

- 1 HART sensor
- 2 Connection cable with 2 mm pins
- 3 VEGATRENN 141/142/151/152

HART sensor on a PLC

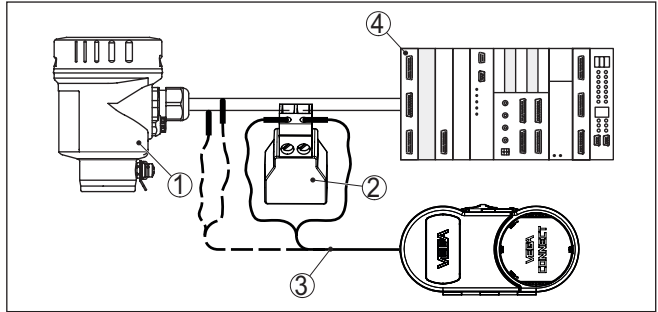

Fig. 9: Connection *plics*® series via HART

- 1 HART sensor
- 2 HART resistance 270 Ω (optional depending on processing)
- 3 Connection cable with 2 mm pins and terminals
- 4 Processing system/PLC/Voltage supply

6 Setup

6.1 Adjustment

Use and adjustment are described in the operating instructions manual as well as in the online help of PACTware and the VEGA-DTMs as well as in the respective device instructions manual.

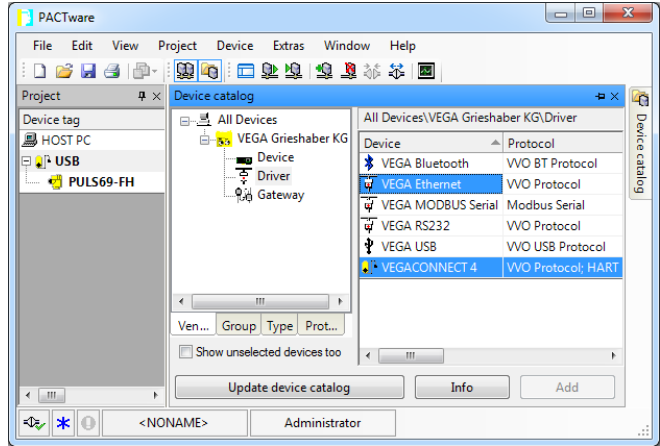

Information:

You find the VEGACONNECT 4 DTM in the device catalogue under the group "Driver". When adding a HART sensors, the window "Channel selection" appears in addition in which you have to select the connection (connection via HART or I²C).

7 Maintenance and fault rectification

7.1 Maintenance

If the device is used properly, no special maintenance is required in normal operation.

7.2 How to proceed if a repair is necessary

You can find an instrument return form as well as detailed information about the procedure in the download area of our homepage: www.vega.com.

By doing this you help us carry out the repair quickly and without having to call back for needed information.

If a repair is necessary, please proceed as follows:

- Print and fill out one form per instrument
- Clean the instrument and pack it damage-proof
- Attach the completed form and, if need be, also a safety data sheet outside on the packaging
- Please contact the agency serving you to get the address for the return shipment. You can find the agency on our home page www.vega.com.

8 Recycling and disposal

8.1 Disposal

The instrument consists of materials which can be recycled by specialised recycling companies. We use recyclable materials and have designed the electronics to be easily separable.

WEEE directive 2002/96/EG

This instrument is not subject to the WEEE directive 2002/96/EG and the respective national laws. Pass the instrument directly on to a specialised recycling company and do not use the municipal collecting points. These may be used only for privately used products according to the WEEE directive.

Correct disposal avoids negative effects on humans and the environment and ensures recycling of useful raw materials.

Materials: see chapter "*Technical data*"

If you have no way to dispose of the old instrument properly, please contact us concerning return and disposal.

9 Supplement

9.1 Technical data

Electrical data

Voltage supply from USB interface	5 V
Max. power consumption	500 mW
Galvanic separation between	- HART - USB - I ² C bus - USB

Ambient conditions

Permissible ambient temperature	-20 ... +60 °C (-4 ... +140 °F)
Storage and transport temperature	-40 ... +70 °C (-40 ... +158 °F)

Electrical protective measures

Protection rating	IP 40
-------------------	-------

Connection cable

USB cable

- Connection to	USB interface of the PC
- Cable length	150 cm (59.055 in)
- Plug connection	USB plug A - USB plug Mini-B
- Cable insulation	min. 0.65 mm (0.256 in)

I²C bus cable

- Connection to	I ² C bus interface
- Cable length	150 cm (59.055 in)
- Plug connection	I ² C bus plug

Cable with 2 mm pins

- Connection to	CONNECT sockets, HART resistor/cable
- Cable length	150 cm (59.055 in)
- Plug connection	2 x 2 mm male connector

HART resistance

Resistor	270 Ω
Tolerance	5 %
Power	1 W

Bluetooth USB adapter

Technical data see attached instruction manual

Material, dimensions, weight

Housing material	impact-resistant plastic (ABS)
Housing dimensions (L x B x H)	160 x 80 x 51 mm (6.299 x 3.15 x 2.008 in)
Weight with connection cables	325 g (0.716 lbs)

Approvals

Instruments with approvals can have different technical specifications depending on the version.

For that reason the associated approval documents of these instruments have to be carefully noted. They are part of the delivery or can be downloaded under "www.vega.com" via "VEGA Tools" and "Instrument search" as well as via "Downloads" and "Approvals".

9.2 Dimensions

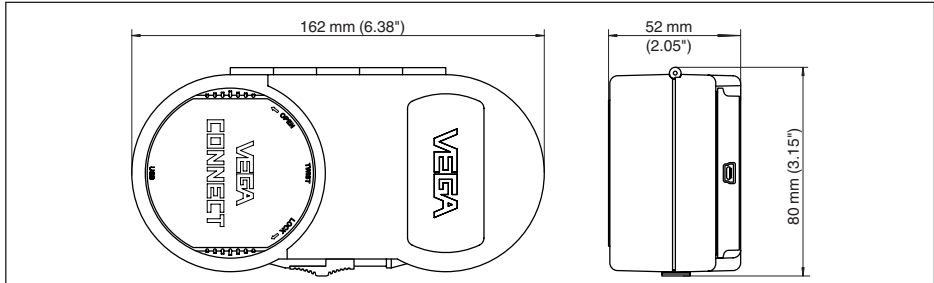

Fig. 11: Dimensions VEGACONNECT 4

9.3 Industrial property rights

VEGA product lines are global protected by industrial property rights. Further information see www.vega.com.

VEGA Produktfamilien sind weltweit geschützt durch gewerbliche Schutzrechte.

Nähere Informationen unter www.vega.com.

Les lignes de produits VEGA sont globalement protégées par des droits de propriété intellectuelle. Pour plus d'informations, on pourra se référer au site www.vega.com.

VEGA lineas de productos están protegidas por los derechos en el campo de la propiedad industrial. Para mayor información revise la pagina web www.vega.com.

Линии продукции фирмы ВЕГА защищаются по всему миру правами на интеллектуальную собственность. Дальнейшую информацию смотрите на сайте www.vega.com.

VEGA系列产品在全球享有知识产权保护。

进一步信息请参见网站www.vega.com。

9.4 Trademark

All the brands as well as trade and company names used are property of their lawful proprietor/originator.

INDEX**C**

Connection 11

D

Driver 9

DTM 7, 16

DTM Collection 9

F

Foundation Fieldbus 7, 11

H

HART 7

– Modem 7

– Resistor 10, 11, 13

I

I²C interface 10

Instrument return form 17

Instrument search 6

Interface converter 7

O

Online help 16

P

PACTware 7, 16

PLC 15

Profibus PA 7, 11

R

Recycling 18

Repair 17

S

Serial number 6

Smartphone app 7

T

Type label 6

U

USB 9

V

Voltage supply 8, 9

W

WEEE directive 18

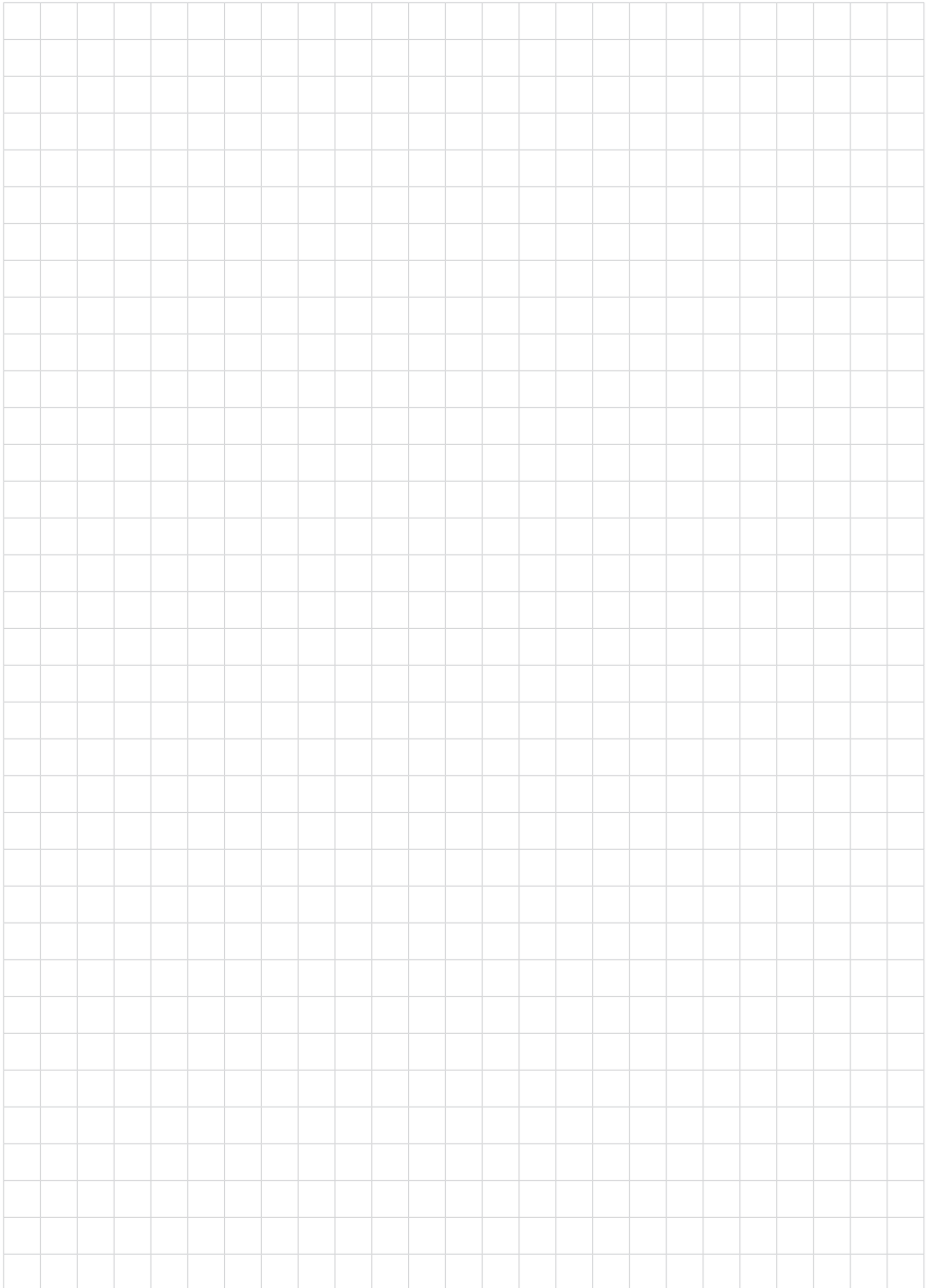

Printing date:

VEGA

All statements concerning scope of delivery, application, practical use and operating conditions of the sensors and processing systems correspond to the information available at the time of printing.

Subject to change without prior notice

© VEGA Grieshaber KG, Schiltach/Germany 2017



32628-EN-170202

VEGA Grieshaber KG
Am Hohenstein 113
77761 Schiltach
Germany

Phone +49 7836 50-0
Fax +49 7836 50-201
E-mail: info.de@vega.com
www.vega.com