

# Operating Instructions

Pressure sensor with metallic measuring cell

## VEGABAR 29

Two-wire 4 ... 20 mA



Document ID: 57087



**VEGA**

# Contents

<b>1</b>	<b>About this document</b> .....	<b>4</b>
1.1	Function .....	4
1.2	Target group .....	4
1.3	Symbols used.....	4
<b>2</b>	<b>For your safety</b> .....	<b>5</b>
2.1	Authorised personnel .....	5
2.2	Appropriate use.....	5
2.3	Warning about incorrect use.....	5
2.4	General safety instructions .....	5
2.5	Installation and operation in the USA and Canada .....	5
<b>3</b>	<b>Product description</b> .....	<b>7</b>
3.1	Configuration.....	7
3.2	Principle of operation.....	9
3.3	Adjustment .....	11
3.4	Packaging, transport and storage.....	11
3.5	Accessories.....	12
<b>4</b>	<b>Mounting</b> .....	<b>13</b>
4.1	General instructions .....	13
4.2	Process pressure measurement.....	15
4.3	Level measurement.....	16
<b>5</b>	<b>Connecting to power supply</b> .....	<b>17</b>
5.1	Preparing the connection .....	17
5.2	Connection procedure.....	17
5.3	Wiring plan .....	20
5.4	Switch-on phase.....	21
<b>6</b>	<b>Access protection</b> .....	<b>22</b>
6.1	Bluetooth radio interface .....	22
6.2	Protection of the parameterization.....	22
6.3	Storing the codes in myVEGA .....	23
<b>7</b>	<b>Setup with smartphone/tablet (Bluetooth)</b> .....	<b>24</b>
7.1	Preparations.....	24
7.2	Connecting.....	24
7.3	Sensor parameter adjustment.....	25
<b>8</b>	<b>Setup with PC/notebook (Bluetooth)</b> .....	<b>26</b>
8.1	Preparations.....	26
8.2	Connecting.....	26
8.3	Parameter adjustment .....	27
<b>9</b>	<b>Menu overview</b> .....	<b>28</b>
9.1	VEGA Tools app and DTM (Bluetooth) .....	28
<b>10</b>	<b>Diagnostics and servicing</b> .....	<b>30</b>
10.1	Maintenance .....	30
10.2	Rectify faults.....	30
10.3	Diagnosis, fault messages .....	31
10.4	Status messages according to NE 107 .....	31

10.5	Software update .....	33
10.6	How to proceed if a repair is necessary.....	34
<b>11</b>	<b>Dismount.....</b>	<b>35</b>
11.1	Dismounting steps.....	35
11.2	Disposal .....	35
<b>12</b>	<b>Certificates and approvals.....</b>	<b>36</b>
12.1	Radio licenses.....	36
12.2	Approvals for Ex areas .....	36
12.3	Approvals as overfill protection.....	36
12.4	Food and pharmaceutical certificates.....	36
12.5	EU conformity.....	36
12.6	NAMUR recommendations .....	36
12.7	Environment management system .....	37
<b>13</b>	<b>Supplement .....</b>	<b>38</b>
13.1	Technical data .....	38
13.2	Dimensions .....	47
13.3	Industrial property rights.....	52
13.4	Licensing information for open source software .....	52
13.5	Trademark .....	52



**Safety instructions for Ex areas**

Take note of the Ex specific safety instructions for Ex applications. These instructions are attached as documents to each instrument with Ex approval and are part of the operating instructions.

Editing status: 2021-02-25

# 1 About this document

## 1.1 Function

This instruction provides all the information you need for mounting, connection and setup as well as important instructions for maintenance, fault rectification, the exchange of parts and the safety of the user. Please read this information before putting the instrument into operation and keep this manual accessible in the immediate vicinity of the device.

## 1.2 Target group

This operating instructions manual is directed to trained personnel. The contents of this manual must be made available to the qualified personnel and implemented.

## 1.3 Symbols used



### Document ID

This symbol on the front page of this instruction refers to the Document ID. By entering the Document ID on [www.vega.com](http://www.vega.com) you will reach the document download.



**Information, note, tip:** This symbol indicates helpful additional information and tips for successful work.



**Note:** This symbol indicates notes to prevent failures, malfunctions, damage to devices or plants.



**Caution:** Non-observance of the information marked with this symbol may result in personal injury.



**Warning:** Non-observance of the information marked with this symbol may result in serious or fatal personal injury.



**Danger:** Non-observance of the information marked with this symbol results in serious or fatal personal injury.



### Ex applications

This symbol indicates special instructions for Ex applications.



### List

The dot set in front indicates a list with no implied sequence.



### Sequence of actions

Numbers set in front indicate successive steps in a procedure.



### Battery disposal

This symbol indicates special information about the disposal of batteries and accumulators.

## 2 For your safety

### 2.1 Authorised personnel

All operations described in this documentation must be carried out only by trained, qualified personnel authorised by the plant operator.

During work on and with the device, the required personal protective equipment must always be worn.

### 2.2 Appropriate use

The VEGABAR 29 is a pressure transmitter for process pressure and hydrostatic level measurement.

You can find detailed information about the area of application in chapter " *Product description*".

Operational reliability is ensured only if the instrument is properly used according to the specifications in the operating instructions manual as well as possible supplementary instructions.

### 2.3 Warning about incorrect use

Inappropriate or incorrect use of this product can give rise to application-specific hazards, e.g. vessel overfill through incorrect mounting or adjustment. Damage to property and persons or environmental contamination can result. Also, the protective characteristics of the instrument can be impaired.

### 2.4 General safety instructions

This is a state-of-the-art instrument complying with all prevailing regulations and directives. The instrument must only be operated in a technically flawless and reliable condition. The operator is responsible for the trouble-free operation of the instrument. When measuring aggressive or corrosive media that can cause a dangerous situation if the instrument malfunctions, the operator has to implement suitable measures to make sure the instrument is functioning properly.

The safety instructions in this operating instructions manual, the national installation standards as well as the valid safety regulations and accident prevention rules must be observed by the user.

For safety and warranty reasons, any invasive work on the device beyond that described in the operating instructions manual may be carried out only by personnel authorised by the manufacturer. Arbitrary conversions or modifications are explicitly forbidden. For safety reasons, only the accessory specified by the manufacturer must be used.

To avoid any danger, the safety approval markings and safety tips on the device must also be observed.

### 2.5 Installation and operation in the USA and Canada

This information is only valid for USA and Canada. Hence the following text is only available in the English language.

Installations in the US shall comply with the relevant requirements of the National Electrical Code (ANSI/NFPA 70).

Installations in Canada shall comply with the relevant requirements of the Canadian Electrical Code.

## 3 Product description

### 3.1 Configuration

#### Scope of delivery

The scope of delivery encompasses:

- VEGABAR 29 pressure transmitter
- Information sheet "*Documents and software*" with:
  - Instrument serial number
  - QR code with link for direct scanning
- Information sheet "*PINs and Codes*" (with Bluetooth versions) with:
  - Bluetooth access code
- Information sheet "*Access protection*" (with Bluetooth versions) with:
  - Bluetooth access code
  - Emergency Bluetooth unlock code
  - Emergency device code

The further scope of delivery encompasses:

- Documentation
  - Quick setup guide VEGABAR 29
  - Ex-specific "*Safety instructions*" (with Ex versions)
  - Radio approvals (versions with Bluetooth)
  - If necessary, further certificates



#### Note:

Optional instrument features are also described in this operating instructions manual. The respective scope of delivery results from the order specification.

#### Scope of this operating instructions

This operating instructions manual applies to the following instrument versions:

- Hardware version from 1.0.0
- Software version from 1.3.0

## Constituent parts

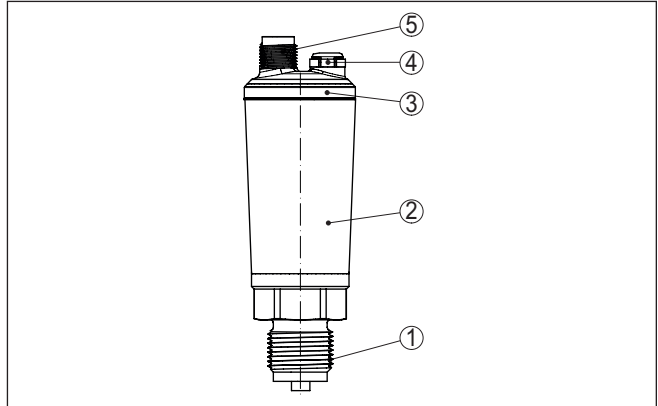

Fig. 1: Components of VEGABAR 29

- 1 Process fitting
- 2 Electronics housing
- 3 LED illuminated ring
- 4 Ventilation/pressure compensation
- 5 Plug connector

## Type label

The type label contains the most important data for identification and use of the instrument.

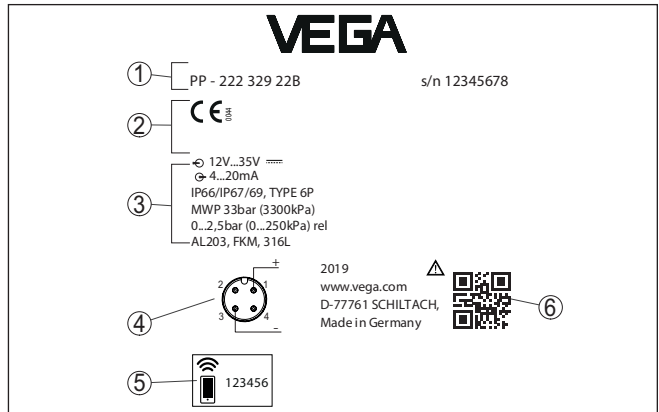

Fig. 2: Layout of the type label (example)

- 1 Order/Serial number
- 2 Field for approvals
- 3 Technical data
- 4 Assignment
- 5 Bluetooth access code
- 6 QR code for device documentation

**Documents and software** Move to "[www.vega.com](http://www.vega.com)" and enter in the search field the serial number of your instrument.



There you can find the following information about the instrument:

- Order data
- Documentation
- Software

Alternatively, you can find all via your smartphone:

- Scan the QR-code on the type label of the device or
- Enter serial number manually in the VEGA Tools app (available free of charge in the respective stores)

### 3.2 Principle of operation

#### Application area

VEGABAR 29 is suitable for applications in virtually all industries. It is used for the measurement of the following pressure types.

- Gauge pressure
- Absolute pressure
- Vacuum

#### Measured products

Measured products are gases, vapours and liquids.

The device is especially suitable for applications with higher temperatures and high pressures.

#### Measured variables

The VEGABAR 29 is suitable for the measurement of the following process variables:

- Process pressure
- Level

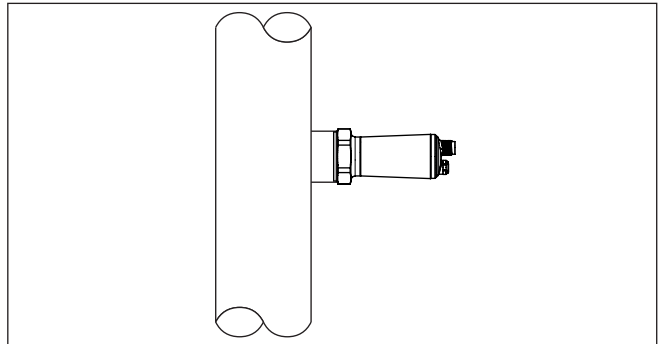

Fig. 3: Process pressure measurement VEGABAR 29

#### Measuring system

The process pressure acts on the sensor element via the process diaphragm. The process pressure causes a resistance change which is converted into a corresponding output signal and output as measured value.

#### Piezoresistive sensor element

Measuring ranges up to 100 bar: piezoresistive sensor element with internal transmission liquid is used.

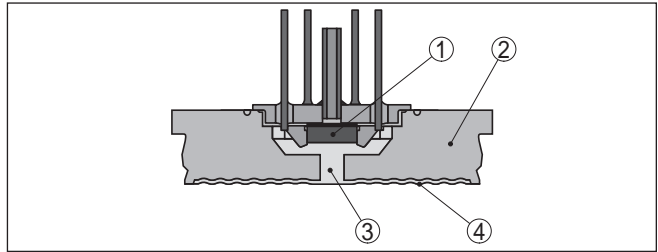

Fig. 4: Configuration of the measuring system with piezoresistive sensor element

- 1 Sensor element
- 2 Base element
- 3 Transmission liquid
- 4 Process diaphragm

### Strain gauge (DMS) sensor element

For measuring ranges above 250 bar, a strain gauge (DMS) sensor element (dry system) is used.

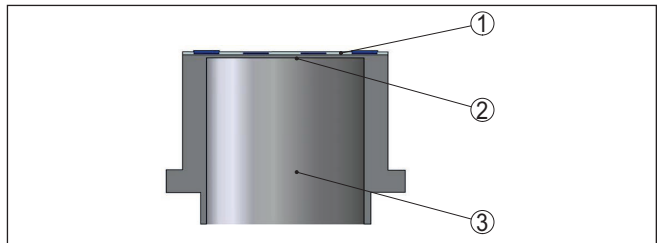

Fig. 5: Configuration of the measuring system with strain gauge (DMS) sensor element

- 1 Sensor element
- 2 Process diaphragm
- 3 Pressure cylinder

### Pressure types

**Relative pressure:** the measuring cell is open to the atmosphere. The ambient pressure is detected in the measuring cell and compensated. It thus has no influence on the measured value.

**Absolute pressure:** the measuring cell contains vacuum and is encapsulated. The ambient pressure is not compensated and does hence influence the measured value.

### Seal concept

The measuring system is completely welded and thus sealed against the process.

The process fitting is sealed against the process by a suitable seal. It must be provided by the customer, depending on the process fitting also included in the scope of delivery, see chapter " *Technical data*", " *Materials and weights*".

### 3.3 Adjustment

#### Wireless adjustment

Devices with integrated Bluetooth module can be adjusted wirelessly via standard adjustment tools: <sup>1)</sup>

- Smartphone/tablet (iOS or Android operating system)
- PC/notebook (Windows operating system)

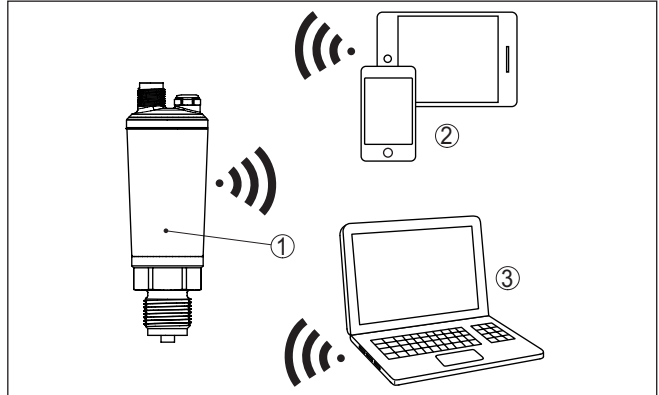

Fig. 6: Wireless connection to standard adjustment tools with integrated Bluetooth LE

- 1 Sensor
- 2 Smartphone/Tablet
- 3 Bluetooth USB adapter

### 3.4 Packaging, transport and storage

#### Packaging

Your instrument was protected by packaging during transport. Its capacity to handle normal loads during transport is assured by a test based on ISO 4180.

The packaging consists of environment-friendly, recyclable cardboard. For special versions, PE foam or PE foil is also used. Dispose of the packaging material via specialised recycling companies.

#### Transport

Transport must be carried out in due consideration of the notes on the transport packaging. Nonobservance of these instructions can cause damage to the device.

#### Transport inspection

The delivery must be checked for completeness and possible transit damage immediately at receipt. Ascertained transit damage or concealed defects must be appropriately dealt with.

#### Storage

Up to the time of installation, the packages must be left closed and stored according to the orientation and storage markings on the outside.

Unless otherwise indicated, the packages must be stored only under the following conditions:

<sup>1)</sup> Reduced effective range with M12 x 1 plug stainless steel (closed metal housing), see chapter "Technical Data"

- Not in the open
- Dry and dust free
- Not exposed to corrosive media
- Protected against solar radiation
- Avoiding mechanical shock and vibration

**Storage and transport temperature**

- Storage and transport temperature see chapter " *Supplement - Technical data - Ambient conditions*"
- Relative humidity 20 ... 85 %

**3.5 Accessories**

The instructions for the listed accessories can be found in the download area on our homepage.

**Welded sockets and adapters**

Welded sockets are used to connect the devices to the process.

Threaded adapters enable simple adaptation of devices with standard threaded fittings, e.g. to process-side hygiene connections.

**Mounting accessories**

The suitable mounting accessories for VEGABAR 29 includes siphons, blocking valves and measuring instrument holders.

## 4 Mounting

### 4.1 General instructions

#### Ambient conditions

The instrument is suitable for standard and extended ambient conditions acc. to DIN/EN/IEC/ANSI/ISA/UL/CSA 61010-1. It can be used indoors as well as outdoors.

#### Process conditions



#### Note:

For safety reasons, the instrument must only be operated within the permissible process conditions. You can find detailed information on the process conditions in chapter " *Technical data*" of the operating instructions or on the type label.

Hence make sure before mounting that all parts of the instrument exposed to the process are suitable for the existing process conditions.

These are mainly:

- Active measuring component
- Process fitting
- Process seal

Process conditions in particular are:

- Process pressure
- Process temperature
- Chemical properties of the medium
- Abrasion and mechanical influences

#### Permissible process pressure (MWP) - Device

The permissible process pressure range is specified by "MWP" (Maximum Working Pressure) on the type label, see chapter " *Structure*". The MWP takes the element of the measuring cell and processing fitting combination with the weakest pressure into consideration and may applied permanently. The specification refers to a reference temperature of +20 °C (+68 °F). It also applies when a measuring cell with a higher measuring range than the permissible pressure range of the process fitting is installed order-related.

In order to prevent damage to the device, a test pressure may only exceed the specified MWP briefly by 1.5 times at reference temperature. The pressure stage of the process fitting as well as the overload resistance of the measuring cell are taken into consideration here (see chapter " *Technical Data*").

In addition, a temperature derating of the process fitting, e. g. with flanges, can limit the permissible process pressure range according to the respective standard.

#### Protection against moisture

Protect your instrument against moisture ingress through the following measures:

- Use a suitable connection cable (see chapter " *Connecting to power supply*")
- Tighten the cable gland or plug connector
- Lead the connection cable downward in front of the cable entry or plug connector

This applies mainly to outdoor installations, in areas where high humidity is expected (e.g. through cleaning processes) and on cooled or heated vessels.

### Ventilation and pressure compensation

Ventilation and pressure compensation for VEGABAR 29 are provided by an air-permeable, moisture-blocking filter element.

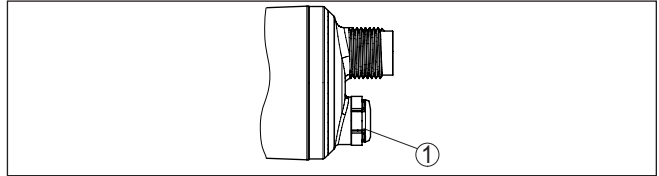

Fig. 7: Position of the filter element

1 Filter element

For effective ventilation, the filter element must always be free of buildup.

### Screwing in

Devices with threaded fitting are screwed into the process fitting with a suitable wrench via the hexagon.

See chapter "Dimensions" for wrench size.



#### Warning:

The housing or the electrical connection may not be used for screwing in! Depending on the device version, tightening can cause damage, e.g. to the rotation mechanism of the housing.

### Permissible process pressure (MWP) - Mounting accessory

The permissible process pressure range is stated on the type label. The instrument should only be operated with these pressures if the mounting accessory used also fulfils these values. This should be ensured by suitable flanges, welded sockets, tension rings with Clamp connections, sealings, etc.

### Temperature limits

Higher process temperatures often mean also higher ambient temperatures. Make sure that the upper temperature limits stated in chapter "Technical data" for the environment of the electronics housing and connection cable are not exceeded.

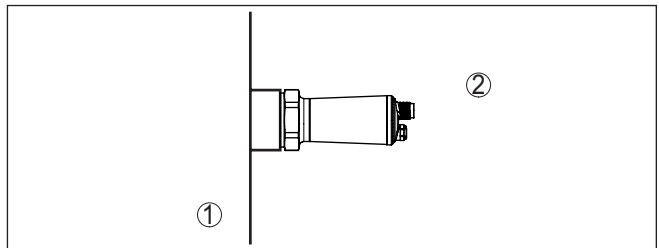

Fig. 8: Temperature ranges

1 Process temperature  
2 Ambient temperature

## 4.2 Process pressure measurement

### In gases

Keep the following in mind when setting up the measuring system:

- Mount the instrument above the measuring point

Possible condensation can then drain off into the process line.

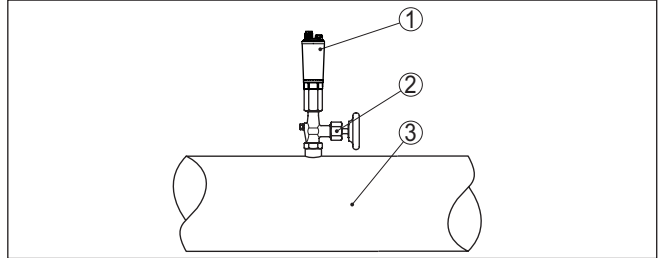

Fig. 9: Measurement setup for process pressure measurement of gases in pipelines

- 1 VEGABAR 29
- 2 Blocking valve
- 3 Pipeline

### In vapours

Keep the following in mind when setting up the measuring system:

- Connect via a siphon

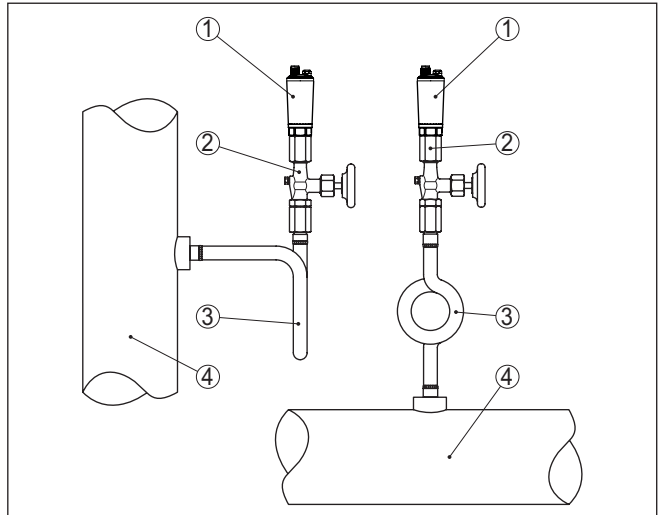

Fig. 10: Measurement setup for process pressure measurement of gases in pipelines

- 1 VEGABAR 29
- 2 Blocking valve
- 3 Siphon in U or circular form
- 4 Pipeline

A protective accumulation of water is formed through condensation in the pipe bends. Even in applications with hot steam, a medium temperature  $< 100\text{ }^{\circ}\text{C}$  on the transmitter is ensured.

### In liquids

Keep the following in mind when setting up the measuring system:

- Mount the instrument below the measuring point

The effective pressure line is always filled with liquid and gas bubbles can bubble up to the process line.

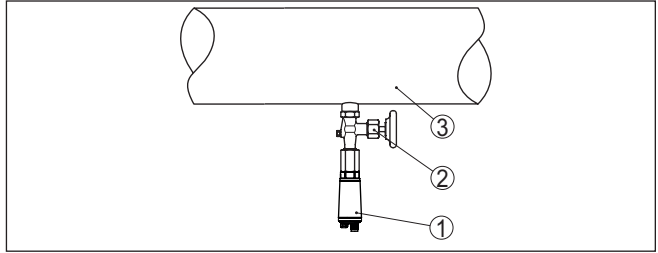

Fig. 11: Measurement setup for process pressure measurement of liquids in pipelines

- 1 VEGABAR 29
- 2 Blocking valve
- 3 Pipeline

### 4.3 Level measurement

#### Measurement setup

Keep the following in mind when setting up the measuring system:

- Mount the instrument below the min. level
- Do not mount the instrument close to the filling stream or emptying area
- Mount the instrument so that it is protected against pressure shocks from the stirrer

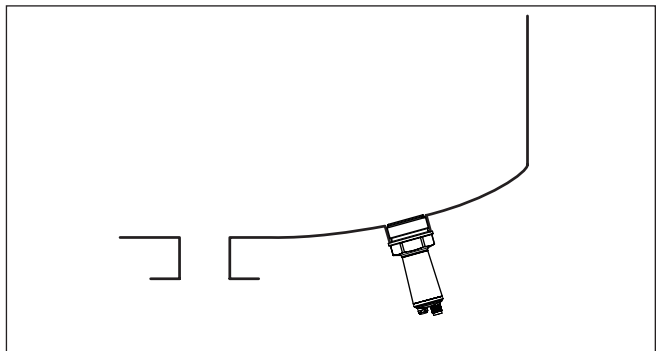

Fig. 12: Measurement setup for level measurement



## 5 Connecting to power supply

### 5.1 Preparing the connection

#### Safety instructions

Always keep in mind the following safety instructions:

- Carry out electrical connection by trained, qualified personnel authorised by the plant operator
- If overvoltage surges are expected, overvoltage arresters should be installed



#### Warning:

Only connect or disconnect in de-energized state.

#### Voltage supply

The data for power supply are specified in chapter " *Technical data*".



#### Note:

Power the instrument via an energy-limited circuit (power max. 100 W) acc. to IEC 61010-1, e.g.

- Class 2 power supply unit (acc. to UL1310)
- SELV power supply unit (safety extra-low voltage) with suitable internal or external limitation of the output current

Keep in mind the following additional factors that influence the operating voltage:

- Lower output voltage of the power supply unit under nominal load (e.g. with a sensor current of 20.5 mA or 22 mA in case of fault)
- Influence of additional instruments in the circuit (see load values in chapter " *Technical data*")

#### Connection cable

Use cable with round cross section. Depending on the plug connection, you have to select the outer diameter of the cable respectively so that the seal effect of the cable gland is ensured.

Depending on the connection method or signal output, the device is connected with standard two, three or four-wire cable without shielding.

### 5.2 Connection procedure

#### M12 x 1 plug

This plug connection requires a complete confectioned cable with counter plug.

#### Plug according to ISO 4400

Proceed as follows:

1. Loosen the screw on the rear of the plug connector
2. Remove the plug connector and seal from VEGABAR 29
3. Remove the plug insert from the plug housing

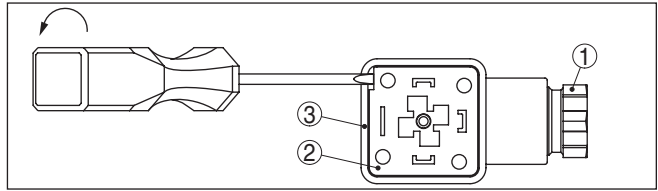

Fig. 13: Loosen the plug insert

- 1 Cable gland
- 2 Plug insert
- 3 Plug housing

4. Remove approx. 5 cm of the cable mantle, strip approx. 1 cm insulation from the individual wires
5. Lead the cable through the cable gland into the plug housing
6. Connect the wire ends to the screw terminals according to the wiring plan

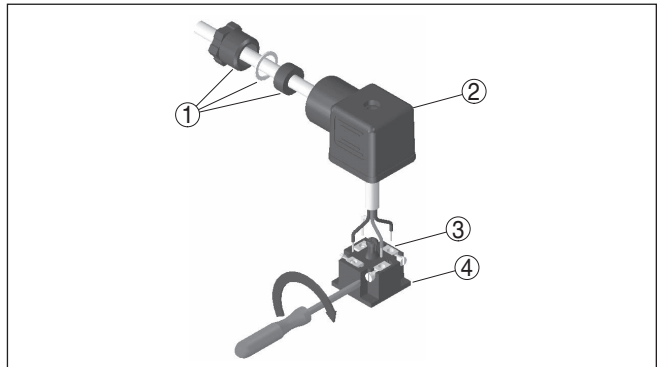

Fig. 14: Connection to the screw terminals

- 1 Cable gland
- 2 Plug housing
- 3 Plug insert
- 4 Plug seal

7. Snap the plug insert into the plug housing and insert the sensor seal
8. Plug the plug insert with seal to VEGABAR 29 and tighten the screw

The electrical connection is finished.

### ISO 4400 plug with hinged cover

Proceed as follows:

1. Loosen the screw in the cover of the plug connector
2. Open the cover and remove it
3. Press the plug insert downwards
4. Loosen the screws of the strain relief and cable entry

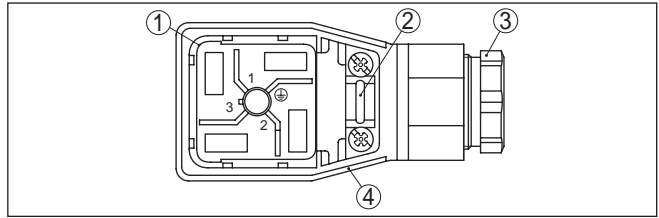

Fig. 15: Loosen the plug insert

- 1 Plug insert
- 2 Strain relief
- 3 Cable gland
- 4 Plug housing

- 5. Remove approx. 5 cm of the cable mantle, strip approx. 1 cm insulation from the individual wires
- 6. Lead the cable through the cable gland into the plug housing
- 7. Connect the wire ends to the screw terminals according to the wiring plan

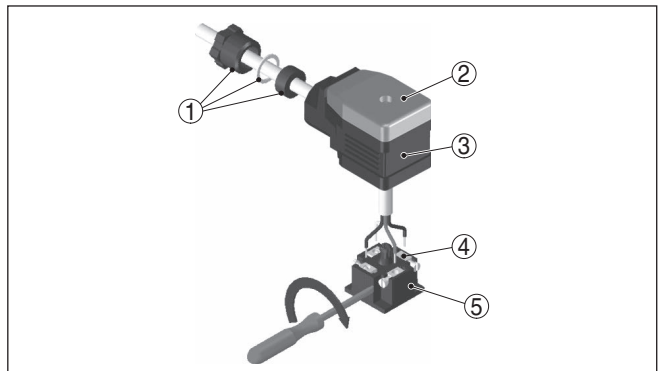

Fig. 16: Connection to the screw terminals

- 1 Cable gland
- 2 Cover
- 3 Plug housing
- 4 Plug insert
- 5 Plug seal

- 8. Snap the plug insert into the plug housing and insert the sensor seal



**Information:**

Note the correct arrangement, see illustration

- 9. Tighten the screws on the strain relief and cable entry
- 10. Hook in the cover and push onto the plug connection, tighten cover screw
- 11. Plug the plug insert with seal to VEGABAR 29 and tighten the screw

The electrical connection is finished.

### Plug according to ISO 4400 with IDC method of termination

For this plug version you can use standard cable with round wire cross-section. The inner conductors do not have to be stripped. The plug connects the conductors automatically when screwing in. Cable diameter 5.5 ... 8 mm, protection IP67.

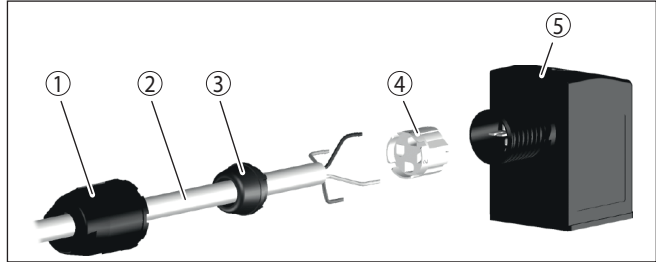

Fig. 17: Connection, valve plug ISO 4400 with IDC crimping technology

- 1 Compression nut
- 2 Cable
- 3 Seal ring
- 4 Terminal insert
- 5 Plug housing

## 5.3 Wiring plan

### M12 x 1 plug

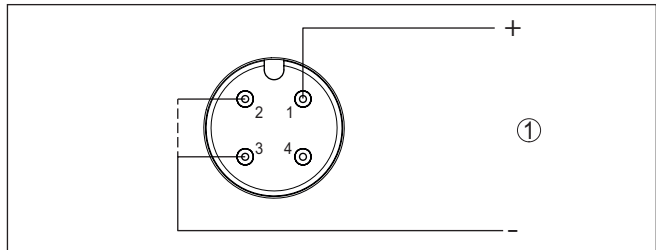

Fig. 18: Wiring plan - two-wire 4 ... 20 mA - M12 x 1 plug

- 1 Voltage supply and signal output

Contact, plug connector	Function/Polarity
1	Voltage supply, signal output/Plus
2	Voltage supply, signal output/Minus
3	Voltage supply, signal output/Minus
4	Free



#### Note:

Contacts 2 and 3 are internally bridged from delivery status approx. week 17/2021. The negative supply can thus be made either on contact 2 or 3.

**Plug according to ISO 4400**

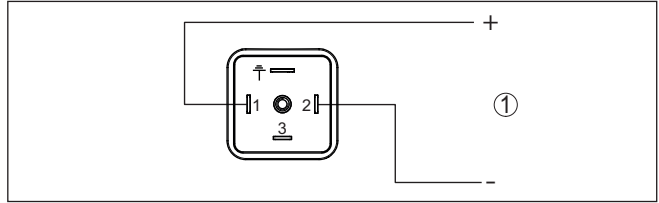



Fig. 19: Wiring plan - two-wire 4 ... 20 mA - plug according to ISO 4400  
 1 Voltage supply and signal output

Contact, plug connector	Function/Polarity
1	Voltage supply, signal output/+
2	Voltage supply, signal output/-
3	Free
	Electrically connected with metal housing

**Direct cable outlet**

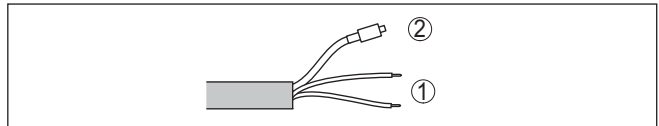

Fig. 20: Wiring plan - Two-wire 4 ... 20 mA - direct cable outlet  
 1 Voltage supply, signal output  
 2 Ventilation

Wire colour	Function/Polarity
Brown	Voltage supply, signal output/Plus
Blue	Voltage supply, signal output/Minus

**5.4 Switch-on phase**

After switching on, the device first carries out a self-check:

- Internal check of the electronics
- The output signal jumps to the set fault current

The current measured value is then output on the signal cable.

## 6 Access protection

### 6.1 Bluetooth radio interface

Devices with a Bluetooth radio interface are protected against unwanted access from outside. This means that only authorized persons can receive measured and status values and change device settings via this interface.

#### Bluetooth access code

A Bluetooth access code is required to establish Bluetooth communication via the adjustment tool (smartphone/tablet/notebook). This code must be entered once when Bluetooth communication is established for the first time in the adjustment tool. It is then stored in the adjustment tool and does not have to be entered again.

The Bluetooth access code is individual for each device. It is printed on the device housing and is also supplied with the device in the information sheet "*PINs and Codes*". It can be changed by the user after the first connection has been established. If the Bluetooth access code has not been entered correctly, a new entry can only be made after a waiting period has elapsed. The waiting time increases with each additional incorrect entry.

#### Emergency Bluetooth unlock code

The emergency Bluetooth access code enables Bluetooth communication to be established in the event that the Bluetooth access code is no longer known. It can't be changed. The emergency Bluetooth access code can be found in information sheet "*Access protection*". If this document is lost, the emergency Bluetooth access code can be retrieved from your personal contact person after legitimation. The storage and transmission of Bluetooth access codes is always encrypted (SHA 256 algorithm).

### 6.2 Protection of the parameterization

The settings (parameters) of the device can be protected against unwanted changes. The parameter protection is deactivated on delivery, all settings can be made.

#### Device code

To protect the parameterization, the device can be locked by the user with the aid of a freely selectable device code. The settings (parameters) can then only be read out, but not changed. The device code is also stored in the adjustment tool. However, unlike the Bluetooth access code, it must be re-entered for each unlock. When using the adjustment app or DTM, the stored device code is then suggested to the user for unlocking.

#### Emergency device code

The emergency device code allows unlocking the device in case the device code is no longer known. It can't be changed. The emergency device code can also be found on the supplied information sheet "*Access protection*". If this document is lost, the emergency device code can be retrieved from your personal contact person after legitimation. The storage and transmission of the device codes is always encrypted (SHA 256 algorithm).

### 6.3 Storing the codes in myVEGA

If the user has a "myVEGA" account, then the Bluetooth access code as well as the device code are additionally stored in his account under "PINs and Codes". This greatly simplifies the use of additional adjustment tools, as all Bluetooth access and device codes are automatically synchronized when connected to the "myVEGA" account

## 7 Setup with smartphone/tablet (Bluetooth)

### 7.1 Preparations

#### System requirements

Make sure that your smartphone/tablet meets the following system requirements:

- Operating system: iOS 8 or newer
- Operating system: Android 5.1 or newer
- Bluetooth 4.0 LE or newer

Download the VEGA Tools app from the "Apple App Store", "Google Play Store" or "Baidu Store" to your smartphone or tablet.

### 7.2 Connecting

#### Connecting

Start the adjustment app and select the function "Setup". The smartphone/tablet searches automatically for Bluetooth-capable instruments in the area.

The message "Connecting ..." is displayed.

The devices found are listed and the search is automatically continued.

Select the requested instrument in the device list.

As soon as the Bluetooth connection to a device is established, the LED display of the device in question flashes blue 4 times.

#### Authenticate

When establishing the connection for the first time, the operating tool and the sensor must authenticate each other. After the first correct authentication, each subsequent connection is made without a new authentication query.

#### Enter Bluetooth access code

For authentication, enter the 6-digit Bluetooth access code in the next menu window. You can find the code on the outside of the device housing and on the information sheet "Pins and Codes" in the device packaging.

For the very first connection, the adjustment unit and the sensor must authenticate each other.

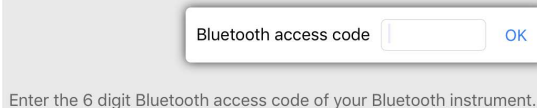

Fig. 21: Enter Bluetooth access code



#### Note:

If an incorrect code is entered, the code can only be entered again after a delay time. This time gets longer after each incorrect entry.

The message "Waiting for authentication" is displayed on the smartphone/tablet.

#### Connected

After connection, the sensor adjustment menu is displayed on the respective adjustment tool.



If the Bluetooth connection is interrupted, e.g. due to a too large distance between the two devices, this is displayed on the adjustment tool. The message disappears when the connection is restored.

**Change device code**

Parameter adjustment of the device is only possible if the parameter protection is deactivated. When delivered, parameter protection is deactivated by default and can be activated at any time.

It is recommended to enter a personal 6-digit device code. To do this, go to menu " *Extended functions*", " *Access protection*", menu item " *Protection of the parameter adjustment*".

**7.3 Sensor parameter adjustment**

**Enter parameters**

The sensor adjustment menu is divided into two halves:

On the left you'll find the navigation section with the menus " *Setup*", " *Display*", " *Diagnosis*" and others.

The selected menu item, recognisable by the colour change, is displayed in the right half.

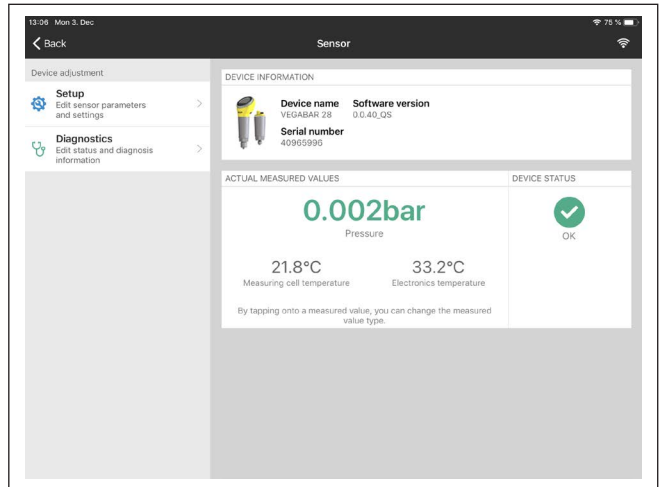

Fig. 22: Example of an app view - Setup measured values

## 8 Setup with PC/notebook (Bluetooth)

### 8.1 Preparations

#### System requirements

Make sure that your PC/notebook meets the following system requirements:

- Operating system Windows 10
- DTM Collection 10/2020 or newer
- Bluetooth 4.0 LE or newer

#### Activate Bluetooth connection

Activate the Bluetooth connection via the project assistant.



#### Note:

Older systems do not always have an integrated Bluetooth LE. In these cases, a Bluetooth USB adapter is required. Activate the Bluetooth USB adapter using the Project Wizard.

After activating the integrated Bluetooth or the Bluetooth USB adapter, devices with Bluetooth are found and created in the project tree.

### 8.2 Connecting

#### Connecting

Select the requested device for the online parameter adjustment in the project tree.

As soon as the Bluetooth connection to a device is established, the LED display of the device in question flashes blue 4 times.

#### Authenticate

When establishing the connection for the first time, the operating tool and the device must authenticate each other. After the first correct authentication, each subsequent connection is made without a new authentication query.

#### Enter Bluetooth access code

For authentication, enter in the next menu window the 6-digit Bluetooth access code:

Fig. 23: Enter Bluetooth access code

You can find the code on the outside of the device housing and on the information sheet "PINs and Codes" in the device packaging.



**Note:**

If an incorrect code is entered, the code can only be entered again after a delay time. This time gets longer after each incorrect entry.

The message "Waiting for authentication" is displayed on the PC/notebook.

**Connected**

After connection, the device DTM appears.

If the connection is interrupted, e.g. due to a too large distance between device and adjustment tool, this is displayed on the adjustment tool. The message disappears when the connection is restored.

**Change device code**

Parameter adjustment of the device is only possible if the parameter protection is deactivated. When delivered, parameter protection is deactivated by default and can be activated at any time.

It is recommended to enter a personal 6-digit device code. To do this, go to menu "Extended functions", "Access protection", menu item "Protection of the parameter adjustment".

**Prerequisites**

**8.3 Parameter adjustment**

For parameter adjustment of the instrument via a Windows PC, the configuration software PACTware and a suitable instrument driver (DTM) according to FDT standard are required. The latest PACTware version as well as all available DTMs are compiled in a DTM Collection. The DTMs can also be integrated into other frame applications according to FDT standard.

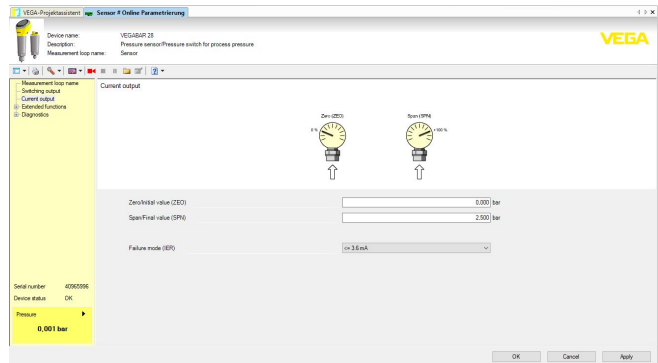

Fig. 24: Example of a DTM view - Adjustment current output

## 9 Menu overview

### 9.1 VEGA Tools app and DTM (Bluetooth)

#### Start image (app)

Menu item	Device information	Actual measured values	Device status
Start image	Device name, software version, serial number	Pressure, output current, measuring cell temperature, electronics temperature, sensor TAG	OK, error indication

#### Main menu

Menu item	Parameter (code acc. to VDMA 24574-1)	Editing section	Basic setting
Measurement loop name	Measurement loop name	19 alphanumeric characters/ special characters	Sensor
Current output	Zero 4 mA (ZEO)	Measuring range begin ... measuring range end	Measuring range begin
	Span 20 mA (SPN)		Measuring range end
	Reaction in case of fault (FER)	$\leq 3.6 \text{ mA}, \geq 21 \text{ mA}$	$\leq 3.6 \text{ mA}$
360° status display (free signalling)	Brightness (LED)	0 %, 10 %, 20 ... 100 %	100 %
	Signalling	Acc. to NAMUR NE 107, free signalling	Switching output
	Fault	Red, yellow ..., individual colour selection, no signalling	Yellow
	Flashing	Yes, no	No
	Operating states	Operating states 1, 2, 3, 4, 5	1
	Upper limit	Measuring range begin ... measuring range end	
	Colour selection	Red, yellow ..., individual colour selection, no signalling	Yellow
	Flashing	Yes, no	No

#### Extended functions

Menu item	Parameter (code acc. to VDMA 24574-1)	Editing section	Basic setting
Damping	Damping (DAM)	0 ... 9.999 s	0 s
	Activate thermo-shock suppression	Yes, no	No
Offset correction	Offset correction (OFS)	Execute, automatic correction	0,000 bar
Adjustment with medium	Apply min. pressure on the sensor	Accept 4 mA (LRV)	-
	Apply max. pressure on the sensor	Accept 20 mA (URV)	

Menu item	Parameter (code acc. to VD-MA 24574-1)	Editing section	Basic setting
Units	Pressure unit (UNI)	mbar, bar, Pa, kPa, MPa, psi, mmH <sub>2</sub> O, mmHg, inH <sub>2</sub> O, inHg	bar
	Temperature (TMP)	°C, °F	°C
Access protection	Bluetooth access code		Device-specific access code
	Protection of the parameterization		Deactivated
Reset	Reset		-

## Diagnostics

Menu item	Parameter	Indication
Status	Device status, parameter change counter	Actual values
Peak value indicator	Process pressure, measuring cell temperature, electronics temperature	Actual values, min. values, max. values
Measured values	Measured values, output, additional measured values	Actual values pressure, current output, electronics temperature, measuring cell temperature
Measured value memory (DTM)	Trend curve	Last values
Simulation	Pressure, current output	Simulated values
Sensor information		Device name, serial number, hardware version, software version, factory calibration date, Device Revision, measuring range begin, measuring range end
Sensor features (DTM)	Sensor characteristics	Features of the instrument version

## 10 Diagnostics and servicing

### 10.1 Maintenance

#### Precaution measures against buildup

In some applications, product buildup on the diaphragm can influence the measuring result. Depending on the sensor and application, take precautions to ensure that heavy buildup, and especially a hardening thereof, is avoided.

#### Cleaning

The cleaning helps that the type label and markings on the instrument are visible.

Take note of the following:

- Use only cleaning agents which do not corrode the housings, type label and seals
- Use only cleaning methods corresponding to the housing protection rating

### 10.2 Rectify faults

#### Reaction when malfunction occurs

The operator of the system is responsible for taking suitable measures to rectify faults.

#### Causes of malfunction

The device offers maximum reliability. Nevertheless, faults can occur during operation. These may be caused by the following, e.g.:

- Sensor
- Process
- Voltage supply
- Signal processing

#### Fault rectification

The first measures are:

- Evaluation of fault messages
- Checking the output signal
- Treatment of measurement errors

A smartphone/tablet with the adjustment app or a PC/notebook with the software PACTware and the suitable DTM offer you further comprehensive diagnostic possibilities. In many cases, the causes can be determined in this way and the faults eliminated.

#### Reaction after fault rectification

Depending on the reason for the fault and the measures taken, the steps described in chapter "Setup" must be carried out again or must be checked for plausibility and completeness.

#### 24 hour service hotline

Should these measures not be successful, please call in urgent cases the VEGA service hotline under the phone no. **+49 1805 858550**.

The hotline is also available outside normal working hours, seven days a week around the clock.

Since we offer this service worldwide, the support is provided in English. The service itself is free of charge, the only costs involved are the normal call charges.

### 10.3 Diagnosis, fault messages

#### 4 ... 20 mA signal

Connect a multimeter in the suitable measuring range according to the wiring plan. The following table describes possible errors in the current signal and helps to eliminate them:

Error	Cause	Rectification
4 ... 20 mA signal not stable	Fluctuating measured value	Set damping
4 ... 20 mA signal missing	Electrical connection faulty	Check connection, correct, if necessary
	Voltage supply missing	Check cables for breaks; repair if necessary
	Operating voltage too low, load resistance too high	Check, adapt if necessary
Current signal greater than 22 mA, less than 3.6 mA	Sensor electronics defective	Replace device or send in for repair depending on device version

#### LED illuminated ring

The LED illuminated ring on the device (see chapter "Configuration") indicates the status of the device. This enables simple on-site diagnosis without the need for tools.



**Note:**

The LED illuminated ring is not available for device versions with continuous stainless steel housing.

Colour <sup>2)</sup>	Permanent light	Flashing
Green	voltage supply on, operation without failure	Message "Maintenance required" is displayed
Yellow	voltage supply on, operation without failure	-
Red	voltage supply on, operation with failure	Message acc. to NE 107 "Function check", "Out of specification" or "Simulation state" is displayed

### 10.4 Status messages according to NE 107

The instrument features self-monitoring and diagnostics according to NE 107 and VDI/VDE 2650. In addition to the status messages in the following tables there are more detailed error messages available under the menu item "Diagnostics" via the respective adjustment module.

#### Status messages

The status messages are divided into the following categories:

- Failure
- Function check
- Out of specification
- Maintenance required

and explained by pictographs:

<sup>2)</sup> Adjustable via VEGA Tools app or PACTware/DTM

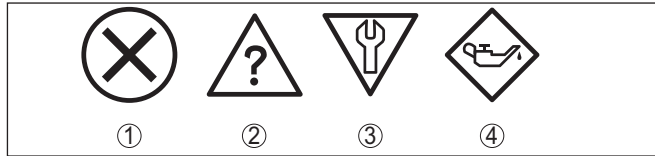

Fig. 25: Pictographs of the status messages

- 1 Failure - red
- 2 Out of specification - yellow
- 3 Function check - orange
- 4 Maintenance required - blue

**Failure:** Due to a malfunction in the instrument, a fault message is output.

This status message is always active. It cannot be deactivated by the user.

**Function check:** The instrument is being worked on, the measured value is temporarily invalid (for example during simulation).

This status message is inactive by default.

**Out of specification:** The measured value is unreliable because an instrument specification was exceeded (e.g. electronics temperature).

This status message is inactive by default.

**Maintenance required:** Due to external influences, the instrument function is limited. The measurement is affected, but the measured value is still valid. Plan in maintenance for the instrument because a failure is expected in the near future (e.g. due to buildup).

This status message is inactive by default.

## Failure

Code Text message	Cause	Rectification
F013 no measured value available	Hardware error in the area of the measuring cell	Send instrument for repair
F017 Adjustment span too small	Adjustment not within specification	Change adjustment
F036 no operable sensor software	Failed or interrupted software update	Repeat software update
F080 General software error	General software error	Restart
F110 Switching points too close together	Selected switching points too close together	Increase the distance between the switching points
F111 Switching points interchanged	Switching point 1 is smaller than switching point 2	Select switching point 1 to greater than switching point 2
F260 Error in the calibration	Checksum error in the calibration values	Send instrument for repair



Code Text message	Cause	Rectification
F261 Error in the instrument settings	Checksum error in the configuration values	Carry out a reset

**Function check**

Code Text message	Cause	Rectification
C700 Simulation active	A simulation is active	Finish simulation Wait for the automatic end after 60 mins.

**Out of specification**

Code Text message	Cause	Rectification
S600 Impermissible electronics temperature	Temperature of the electronics in the non-specified range	Check ambient temperature Insulate electronics
S604 Switching output overloaded	Overload or short circuit at output 1 or 2	Electrical connection, check load resistance

**Maintenance**

Code Text message	Cause	Rectification
M504 Error at a device interface	Interference of the internal communication to Bluetooth	Restart Send instrument for repair
M510 No communication with the main controller	Fault in internal communication with the display	Restart Send instrument for repair

**10.5 Software update**

The device software is updated via Bluetooth.

The following components are required:

- Instrument
- Voltage supply
- PC/notebook with PACTware/DTM and Bluetooth USB adapter
- Current instrument software as file

You can find the current instrument software as well as detailed information on the procedure in the download area of our homepage.



**Caution:**

Instruments with approvals can be bound to certain software versions. Therefore make sure that the approval is still effective after a software update is carried out.

You can find detailed information in the download area on our homepage.

### **10.6 How to proceed if a repair is necessary**

You can find an instrument return form as well as detailed information about the procedure in the download area of our homepage. By doing this you help us carry out the repair quickly and without having to call back for needed information.

In case of repair, proceed as follows:

- Print and fill out one form per instrument
- Clean the instrument and pack it damage-proof
- Attach the completed form and, if need be, also a safety data sheet outside on the packaging
- Ask the agency serving you to get the address for the return shipment. You can find the agency on our homepage.

## 11 Dismount

### 11.1 Dismounting steps

**Warning:**

Before dismantling, be aware of dangerous process conditions such as e.g. pressure in the vessel or pipeline, high temperatures, corrosive or toxic media etc.

Take note of chapters "*Mounting*" and "*Connecting to voltage supply*" and carry out the listed steps in reverse order.

### 11.2 Disposal

The device is made of recyclable materials. For this reason, it should be disposed of by a specialist recycling company. Observe the applicable national regulations.

## 12 Certificates and approvals

### 12.1 Radio licenses

#### Bluetooth

The Bluetooth radio module in the device has been tested and approved according to the current edition of the applicable country-specific norms or standards.

The confirmations as well as regulations for use can be found in the document " *Radio licenses*" supplied or on our homepage.

### 12.2 Approvals for Ex areas

Approved versions for use in hazardous areas are available or in preparation for the device series.

You can find the relevant documents on our homepage.

### 12.3 Approvals as overfill protection

Approved versions for use as part of an overfill protection system are available or in preparation for this device series.

The corresponding approvals can be found on our homepage.

### 12.4 Food and pharmaceutical certificates

Versions for use in the food and pharmaceutical industries are available or in preparation.

The corresponding certificates can be found on our homepage.

### 12.5 EU conformity

The device fulfils the legal requirements of the applicable EU directives. By affixing the CE marking, we confirm the conformity of the instrument with these directives.

The EU conformity declaration can be found on our homepage.

Due to the design of its process fittings, the device does not subject of EU pressure device directive if it is operated at process pressures  $\leq 200$  bar. <sup>3)</sup>

### 12.6 NAMUR recommendations

NAMUR is the automation technology user association in the process industry in Germany. The published NAMUR recommendations are accepted as the standard in field instrumentation.

The device fulfils the requirements of the following NAMUR recommendations:

- NE 21 – Electromagnetic compatibility of equipment
- NE 43 – Signal level for fault information from measuring transducers

<sup>3)</sup> Exception: Versions with measuring ranges from 250 bar. These are subject of the EU Pressure Device Directive.

- NE 53 – Compatibility of field devices and display/adjustment components
- NE 107 – Self-monitoring and diagnosis of field devices

For further information see [www.namur.de](http://www.namur.de).

## 12.7 Environment management system

Protection of the environment is one of our most important duties. That is why we have introduced an environment management system with the goal of continuously improving company environmental protection. The environment management system is certified according to DIN EN ISO 14001. Please help us fulfil this obligation by observing the environmental instructions in chapters "*Packaging, transport and storage*", "*Disposal*" of these operating instructions.

## 13 Supplement

### 13.1 Technical data

#### Note for approved instruments

The technical data in the respective safety instructions which are included in delivery are valid for approved instruments (e.g. with Ex approval). These data can differ from the data listed herein, for example regarding the process conditions or the voltage supply.

All approval documents can be downloaded from our homepage.

#### Materials and weights

##### Materials, wetted parts

Process fitting	316L
Diaphragm	
– Standard	316L
– From measuring range 250 mbar	316L, Elgiloy (2.4711)
Seal for process fitting (in the scope of delivery)	
– Thread G $\frac{1}{2}$ (EN 837), thread G $\frac{1}{2}$ inside G $\frac{1}{4}$ (ISO 228-1), thread G $\frac{1}{2}$ inside 11.4 mm (ISO 228-1), thread M20 x 1.5 (EN 837), thread G $\frac{1}{2}$ (DIN 3852-A)	Klingersil C-4400
– Further thread versions	Depending on the configuration

##### Materials for applications in foodstuffs

Surface quality, hygienic fittings, typ.

– Process fitting	$R_a < 0.8 \mu\text{m}$
-------------------	-------------------------

##### Materials, non-wetted parts

Electronics housing	316L
Illuminated ring	PC
Internal transmission liquid piezoresistive measuring cell	Synthetic oil <sup>4)</sup>
M12 x 1 plug connector	
– Contact support/Housing cap	PBT/PC, 1.4404
– Contacts	CuZn, nickel layer and 0.8 $\mu\text{m}$ gold-plated
Plug connector according to ISO 4400	
– Contact, housing plug	PBT/PC
– Housing connector plug	PA
– Lid screw	StSt
– Contact surface	German silver
– Plug seal	Silicone
Direct cable outlet	
– Cable enclosure	PBT/PC, 1.4404

<sup>4)</sup> Transmission liquid with measuring ranges up to 100 bar. With measuring ranges from 250 bar dry measuring cell.

– Cable	PUR
Weight	approx. 0.25 kg (0.55 lbs)

## Torques

Max. torque for process fitting (examples)

– Clamp	5/10 Nm (3.688/7.376 lbf ft)
– Varivent	20 Nm (14.75 lbf ft)
– Thread G $\frac{1}{2}$ (ISO 228-1), G $\frac{3}{4}$ (DIN 3852-E), M30 x 1.5, Ingold, NPT connections	30 Nm (22.13 lbf ft)
– SMS, collar socket DIN 11851, DIN 11864-1, Form A	40 Nm (29.50 lbf ft)
– Thread G $\frac{1}{2}$ (EN 837), G1 (ISO 228-1), G1 $\frac{1}{2}$ (DIN 3852-A)	50 Nm (36.88 lbf ft)
– Thread G1 with conus	100 Nm (73.76 lbf ft)

## Input variable

The specifications are only an overview and refer to the measuring cell. Limitations due to the material and version of the process fitting as well as the selected pressure type are possible. The specifications on the nameplate apply.<sup>5)</sup>

## Nominal measuring ranges and overload capability in bar/kPa

Nominal range	Overload capacity, max. pressure	Overload capacity, min. pressure
Gauge pressure		
0 ... +0.4 bar/0 ... +40 kPa	+4 bar/+400 kPa	-1 bar/-100 kPa
0 ... +1 bar/0 ... +100 kPa	+4 bar/+400 kPa	-1 bar/-100 kPa
0 ... +2.5 bar/0 ... +250 kPa	+10 bar/+1000 kPa	-1 bar/-100 kPa
0 ... +5 bar/0 ... +500 kPa	+20 bar/+2000 kPa	-1 bar/-100 kPa
0 ... +10 bar/0 ... +1000 kPa	+40 bar/+4000 kPa	-1 bar/-100 kPa
0 ... +25 bar/0 ... +2500 kPa	+120 bar/+12 MPa	-1 bar/-100 kPa
0 ... +60 bar/0 ... +6000 kPa	+300 bar/+30 MPa	-1 bar/-100 kPa
0 ... +100 bar/0 ... +10 MPa	+300 bar/+30 MPa	-1 bar/-100 kPa
0 ... +250 bar/0 ... +25 MPa	+500 bar/+50 MPa	-1 bar/-100 kPa
0 ... +600 bar/0 ... +60 MPa	+1200 bar/+120 MPa	-1 bar/-100 kPa
0 ... +1000 bar/0 ... +100 MPa	+2000 bar/+200 MPa	-1 bar/-100 kPa
-0.2 ... +0.2 bar/-20 ... +20 kPa	+4 bar/+400 kPa	-1 bar/-100 kPa
-0.5 ... +0.5 bar/-50 ... +50 kPa	+4 bar/+400 kPa	-1 bar/-100 kPa
-1 ... 0 bar/-100 ... 0 kPa	+4 bar/+400 kPa	-1 bar/-100 kPa
Absolute pressure		
0 ... 1 bar/0 ... 100 kPa	+4 bar/+400 kPa	0 bar abs.

<sup>5)</sup> Data on overload capability apply for reference temperature.

Nominal range	Overload capacity, max. pressure	Overload capacity, min. pressure
0 ... 2.5 bar/0 ... 250 kPa	+10 bar/+1000 kPa	0 bar abs.
0 ... 5 bar/0 ... 500 kPa	+20 bar/+2000 kPa	0 bar abs.
0 ... 10 bar/0 ... 1000 kPa	+40 bar/+4000 kPa	0 bar abs.
0 ... 25 bar/0 ... 2500 kPa	+120 bar/+12 MPa	0 bar abs.

### Nominal measuring ranges and overload capacity in psi

Nominal range	Overload capacity, max. pressure	Overload capacity, min. pressure
Gauge pressure		
0 ... +5 psig	+60 psig	-14.5 psig
0 ... +15 psig	+60 psig	-14.5 psig
0 ... +30 psig	+145 psig	-14.5 psig
0 ... +75 psig	+290 psig	-14.5 psig
0 ... +150 psig	+580 psig	-14.5 psig
0 ... +300 psig	+1740 psig	-14.5 psig
0 ... +900 psig	+4350 psig	-14.5 psig
0 ... +1450 psig	+4350 psig	-14.5 psig
0 ... +3000 psig	+7250 psig	-14.5 psig
0 ... +9000 psig	+17400 psig	-14.5 psig
0 ... +15000 psig	+29000 psig	-14.5 psig
-3 ... +3 psig	+60 psig	-14.5 psig
-7 ... +7 psig	+60 psig	-14.5 psig
-14.5 ... 0 psig	+60 psig	-14.5 psig
Absolute pressure		
0 ... +15 psi	+43 psi	0 psi
0 ... +30 psi	+145 psi	0 psi
0 ... +75 psi	+290 psi	0 psi
0 ... +150 psi	+580 psi	0 psi
0 ... +300 psi	+1740 psi	0 psi

### Adjustment ranges

Specifications refer to the nominal measuring range, pressure values lower than -1 bar cannot be set

Zero/Span adjustment:

- Zero -20 ... +95 %
- Span -120 ... +120 %

Maximum permissible Turn Down Unlimited (recommended 20 : 1)



**Switch-on phase**

Start-up time with operating voltage $U_b$	$\leq 2$ s
Starting current for run-up time	$\leq 3.6$ mA

**Output variable - two-wire 4 ... 20 mA**

Output signal	4 ... 20 mA - passive
Connection technology	Two-wire
Range of the output signal	3.8 ... 20.5 mA
Signal resolution	5 $\mu$ A
Fault signal, current output (adjustable)	$\leq 3.6$ mA, $\geq 21$ mA, last measured value
Max. output current	21.5 mA
Load	See load resistance under Power supply
Transferred measured value	Pressure

**Dynamic behaviour output**

Dynamic characteristics - Current output <sup>6)</sup>

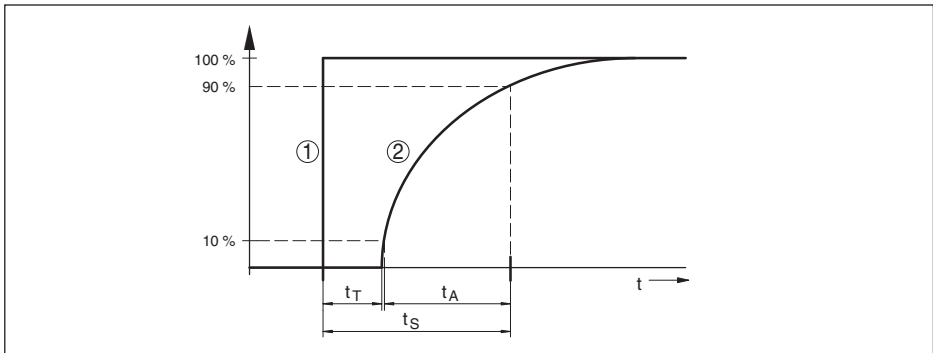

Fig. 26: Behaviour the current output in case of sudden change of the process variable.  $t_T$ : dead time;  $t_A$ : rise time;  $t_S$ : jump response time

- 1 Process variable
- 2 Output signal

Size	Time
Dead time	$\leq 2$ ms
Rise time (10 ... 90 %)	$\leq 4$ ms
Step response time (ti: 0 s, 10 ... 90 %)	$\leq 6$ ms

Damping (63 % of the input variable) 0 ... 9 s, adjustable

**Reference conditions and influencing variables (according to DIN EN 60770-1)**

Reference conditions according to DIN EN 61298-1

- Temperature +18 ... +30 °C (+64 ... +86 °F)

<sup>6)</sup> Depending on medium and temperature

– Relative humidity	45 ... 75 %
– Air pressure	860 ... 1060 mbar/86 ... 106 kPa (12.5 ... 15.4 psi)
Determination of characteristics	Limit point adjustment according to IEC 61298-2
Characteristic curve	Linear
Reference installation position	upright, diaphragm points downward
Influence of the installation position	≤ 5 mbar/0.5 kPa (0.073 psig)

### Deviation (according to IEC 60770)

Applies to the 4 ... 20 mA current output and refers to the adjusted span. Turn down (TD) is the relation nominal measuring range/adjusted span.

Accuracy class	Non-linearity, hysteresis and repeatability with TD 1 : 1 up to 5 : 1	Non-linearity, hysteresis and repeatability with 5 : 1
0.3 %	< 0.3 %	< 0.06 % x TD

### Influence of the medium or ambient temperature

Average temperature coefficient of the zero signal

- In the compensated temperature range <sup>7)</sup> < 0.15 %/10 K
- Outside the compensated temperature range typ. 0.3 %/10 K

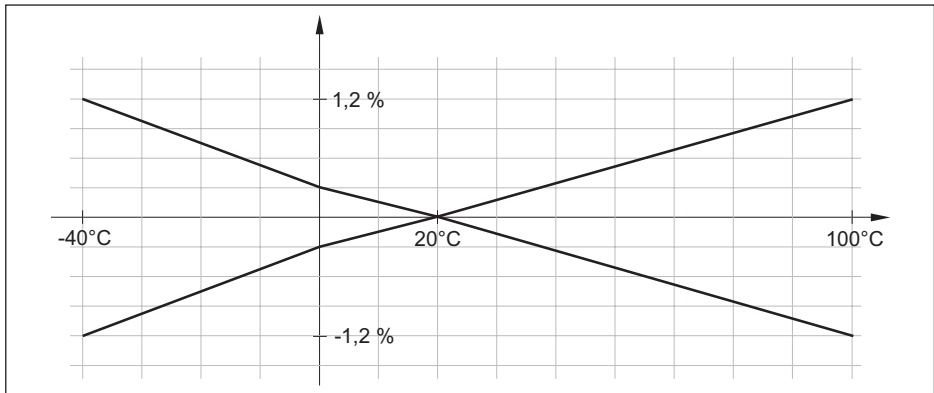

Fig. 27: Temperature error with TD 1 : 1

### Long-term stability (according to DIN 16086)

Specifications refer to the set span. Turn down (TD) is the ratio: nominal measuring range/set span.

Time period	Long-term drift zero signal and output span
One year	< 0.1 % x TD
Two years	< 0.15 % x TD
Five years	< 0.2 % x TD

<sup>7)</sup> 0 ... +100 °C (+32 ... +212 °F)

Time period	Long-term drift zero signal and output span
Ten years	< 0.4 % x TD

### Ambient conditions

Ambient temperature	-40 ... +80 °C (-40 ... +176 °F)
Storage and transport temperature	-40 ... +80 °C (-40 ... +176 °F)
Relative humidity	20 ... 85 %

### Mechanical environmental conditions

Vibrations (oscillations)	Classe 4M8 acc. to IEC 60271-3-4 (5 g at 4 ... 200 Hz)
Impacts (mechanical shock)	Class 6M4 acc. to IEC 60271-3-6 (50 g, 2.3 ms)
Impact resistance	
– Plug according to ISO 4400	IK07 acc. to IEC 62262
– M12 x 1 plug, direct cable outlet	IK05 acc. to IEC 62262

### Process conditions

#### Process temperature

Process temperature

– Standard seal	-40 ... +130 °C (-40 ... +266 °F)
– Seal FKM (VP2/A)	-20 ... +130 °C (-4 ... +266 °F)
– EPDM (A+P 70.10-02)	-40 ... +130 °C (-40 ... +266 °F)

#### Temperature derating

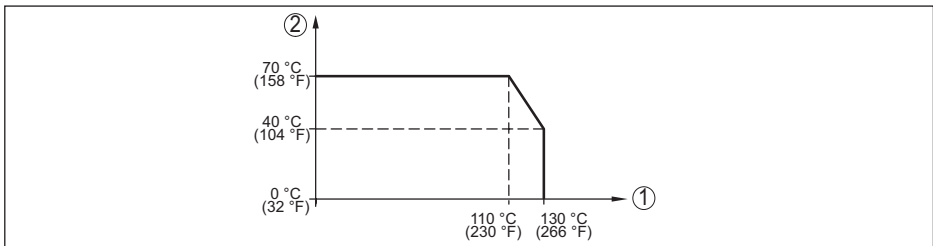

Fig. 28: Temperature derating VEGABAR 29

- 1 Process temperature
- 2 Ambient temperature

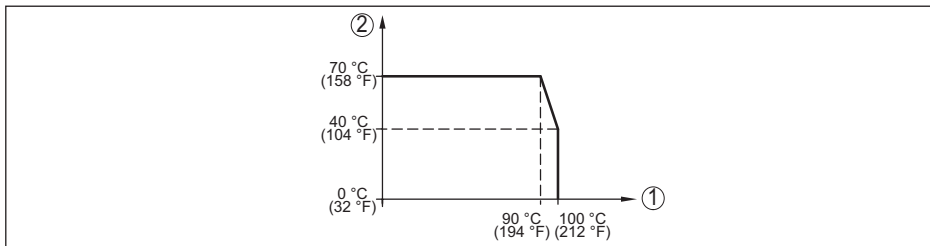

Fig. 29: Temperature derating VEGABAR 29, with activated Bluetooth communication

- 1 Process temperature
- 2 Ambient temperature

**SIP process temperature<sup>8)</sup>**

Device configuration suitable for vapour, i.e. measuring cell seal EPDM or FFKM (Perlast G74S), previous CIP cleaning up to max. +80 °C (+176 °F):<sup>9)</sup>

Vapour stratification up to

- 15 minutes +150 °C (+302 °F)
- 30 minutes +140 °C (+284 °F)
- 1 hour +135 °C (+275 °F)

**Process pressure**

Max. permissible process pressure see specification "MWP" on the type label<sup>10)</sup>

Min. permissible process pressure<sup>11)</sup>

- -40 ... +60 °C (-40 ... +140 °F) 2 mbar<sub>abs</sub> (200 Pa<sub>abs</sub>)
- +60 ... +130 °C (-40 ... +266 °F) 50 mbar<sub>abs</sub> (5 kPa<sub>abs</sub>)

**Indication**

Status indication LED illuminated ring (green-yellow-red)

**Adjustment**

PC/Notebook PACTware/DTM  
 Smartphone/Tablet Adjustment app

**Measuring cell temperature**

Range -40 ... +130 °C (-40 ... +266 °F)  
 Resolution < 0.2 K  
 Deviation ±3 K  
 Output of the temperature values via<sup>12)</sup> Display and adjustment unit, Bluetooth, IO-Link

**Bluetooth interface**

Bluetooth standard Bluetooth 5.0 (downward compatible to Bluetooth 4.0 LE)

<sup>8)</sup> SIP = Sterilization in place  
<sup>9)</sup> CIP = Cleaning in place  
<sup>10)</sup> MWP: Maximum Working Pressure  
<sup>11)</sup> Measuring ranges up to 100bar/10 MPa  
<sup>12)</sup> Depending on the instrument version

Frequency	2.402 ... 2.480 GHz
Max. emitted power	+2.2 dBm
Max. number of participants	1
Effective range typ. <sup>13)</sup>	25 m (82 ft)

---

### Electromechanical data

---

#### Angled plug connector

- Version 4-pin according to ISO 4400
- Cable gland M16 x 1.5 (for cable diameter 4.5 ... 7 mm)
- Screw terminals for cable cross-section up to 1.5 mm<sup>2</sup> (AWG 15)

#### Angle plug connector with flap lid

- Version 4-pin according to ISO 4400
- Cable gland M16 x 1.5 (for cable diameter 4.5 ... 11 mm)
- Screw terminals for cable cross-section up to 1.5 mm<sup>2</sup> (AWG 15)

#### Angled plug connector with IDC method of termination

- Version 4-pin according to ISO 4400
- Wire cross-section 0.5 ... 1 mm<sup>2</sup> (AWG 20 ... AWG 17)
- Strand diameter > 0.1 mm
- Wire diameter 1.6 ... 2 mm
- Outer cable diameter 5.5 ... 8 mm
- Connection frequency (on the same cross-section) 10 x

#### Round plug connector 4-pole with M12 x 1 screw connection

#### Direct cable outlet

- Length 5 m (16.4 ft), 10 m (32.81 ft), 25 m (82.02 ft)
- Wire cross-section 0.34 mm<sup>2</sup> (AWG 21)
- Diameter two-wire approx. 6 mm
- Diameter three-wire approx. 8 mm
- Min. bending radius (at 25 °C/77 °F) 25 mm

---

### Voltage supply

---

Operating voltage $U_B$	12 ... 35 V DC
Reverse voltage protection	Integrated
Permissible residual ripple	
- for $U_N$ 12 V DC ( $12 V < U_B < 18 V$ )	$\leq 0.7 V_{eff}$ (16 ... 400 Hz)
- for $U_N$ 24 V DC ( $18 V < U_B < 35 V$ )	$\leq 1.0 V_{eff}$ (16 ... 400 Hz)
Load resistor	
- Calculation	$(U_B - U_{min})/0.022 A$

<sup>13)</sup> Depending on the local conditions; with M12 x 1 plug stainless steel (closed full metal housing) effective range up to approx. 5 m (16.40 ft)

– Example - for  $U_B = 24$  V DC  $(24 \text{ V} - 12 \text{ V})/0.022 \text{ A} = 545 \Omega$

---

### Electrical protective measures

---

Potential separation Electronics potential free up to 500 V AC

Protection rating

Connection technology	Protection according to EN 60529/IEC 529	Protection according to NEMA/UL 50E
M12 x 1 plug	IP66/IP67/IP69	Type 6P
Plug according to ISO 4400	IP65	Type 4X
ISO 4400 plug with hinged cover		
Plug according to ISO 4400 with IDC method of termination		
Direct cable outlet	IP66/IP68 (0.5 bar)	Type 6P

Altitude above sea level 5000 m (16404 ft)

Protection class III

Pollution degree 4

## 13.2 Dimensions

### Connection technology

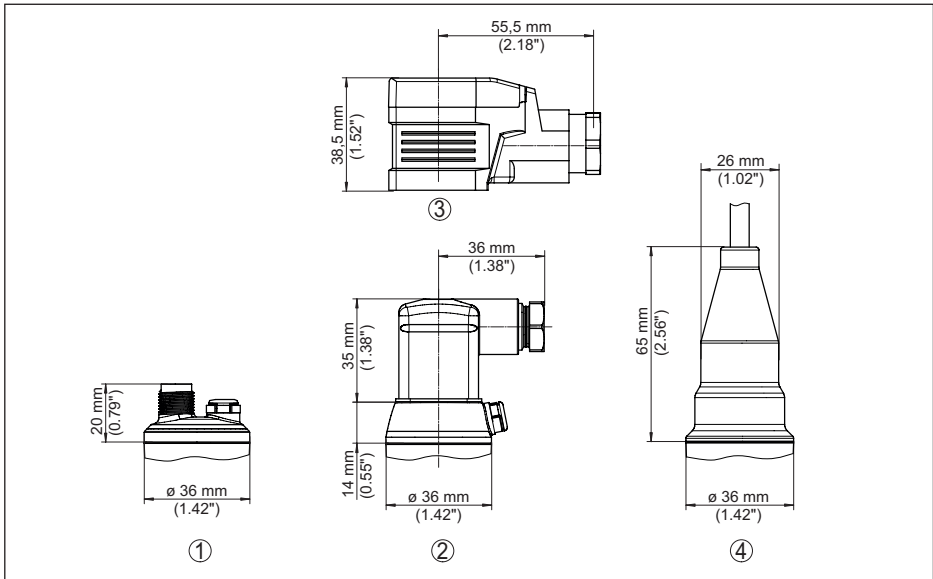

Fig. 30: Connection technology VEGABAR 29

- 1 M12 x 1 plug connector
- 2 Plug connector according to ISO 4400
- 3 Plug connector according to ISO 4400 with hinged cover
- 4 Direct cable outlet

## VEGABAR 29, threaded fitting not front-flush

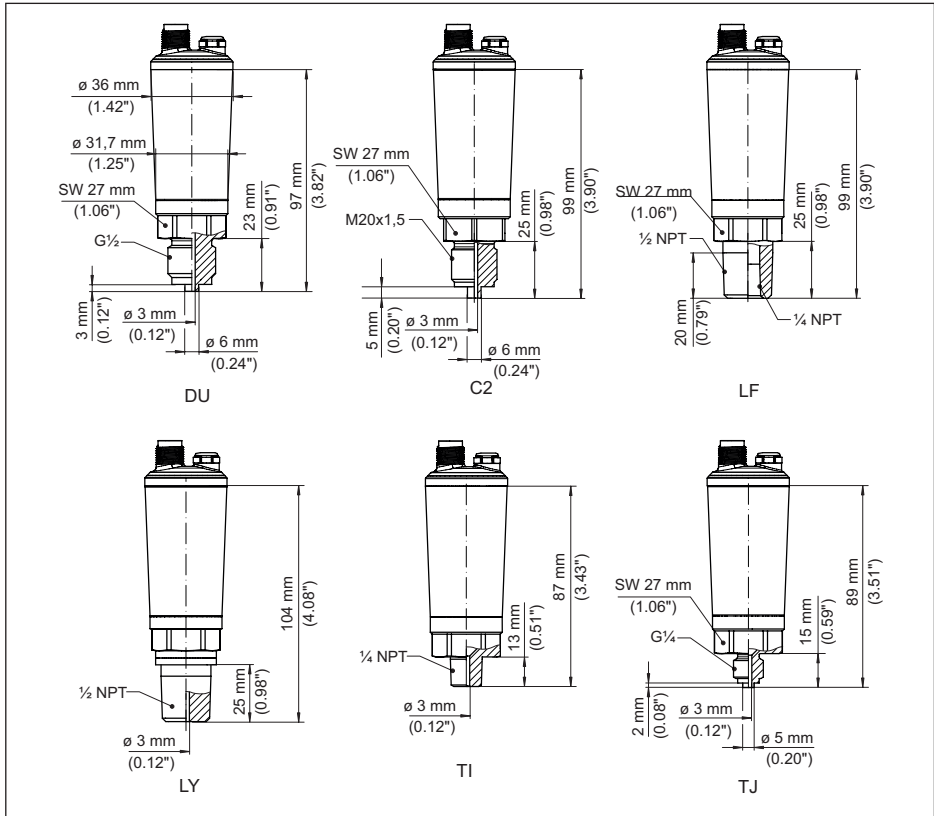
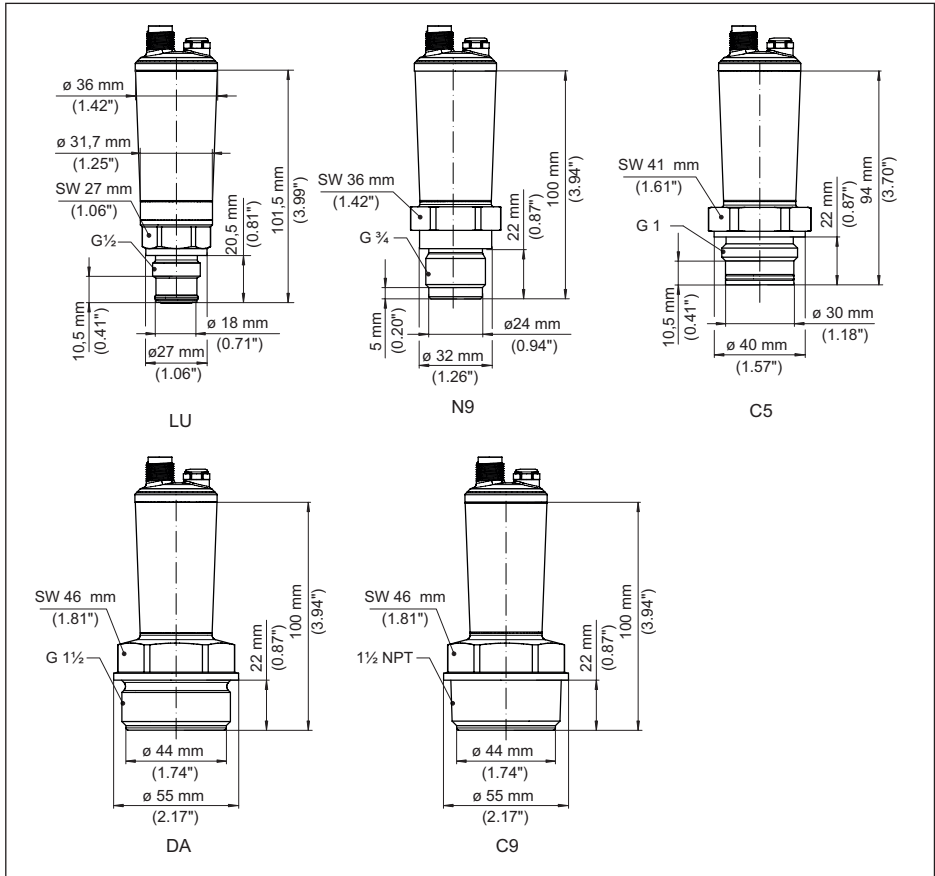

Fig. 31: VEGABAR 29, threaded fitting not front-flush

- DU Thread  $G\frac{1}{2}$  (EN 837), manometer connection  
 C2 Thread M20 x 1.5 (EN 837), manometer connection  
 LF Thread  $\frac{1}{2}$  NPT, inside  $\frac{1}{4}$  NPT (ASME B1.20.1)  
 LY Thread  $\frac{1}{2}$  NPT (ASME B1.20.1)  
 TI Thread  $\frac{1}{4}$  NPT (ASME B1.20.1)  
 TJ Thread  $G\frac{1}{4}$  (ISO 228-1)



**VEGABAR 29, threaded fitting front-flush**



*Fig. 32: VEGABAR 29, threaded fitting front-flush*

- LU Thread G $\frac{1}{2}$  (ISO 228-1)
- N9 Thread G $\frac{3}{4}$  (DIN 3852-E)
- C5 Thread G1 (ISO 228-1)
- DA Thread G1 $\frac{1}{2}$  (DIN 3852-A)
- C9 Thread 1 $\frac{1}{2}$  NPT (ASME B1.20.1)

**VEGABAR 29, threaded fitting front-flush with cone/extension**

Fig. 33: VEGABAR 29, cone/extension fitting

DH Thread G1 (ISO 228-1), cone 40°

LX Thread G1 (ISO 228-1), hygienic design

VEGABAR 29, hygienic fitting

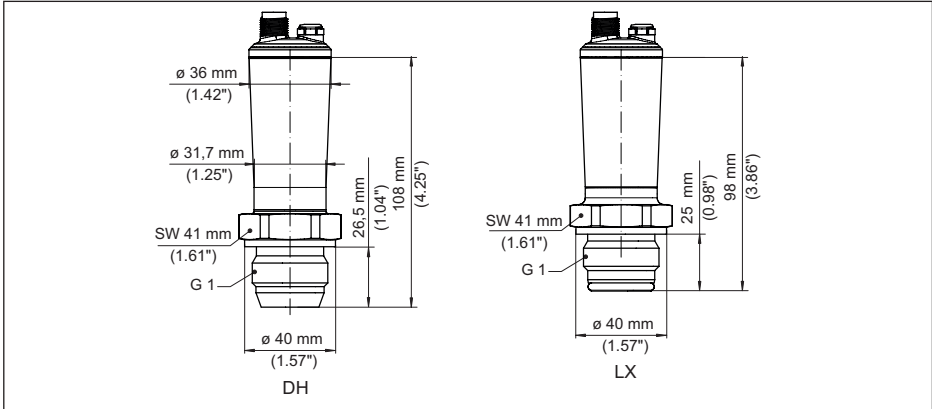
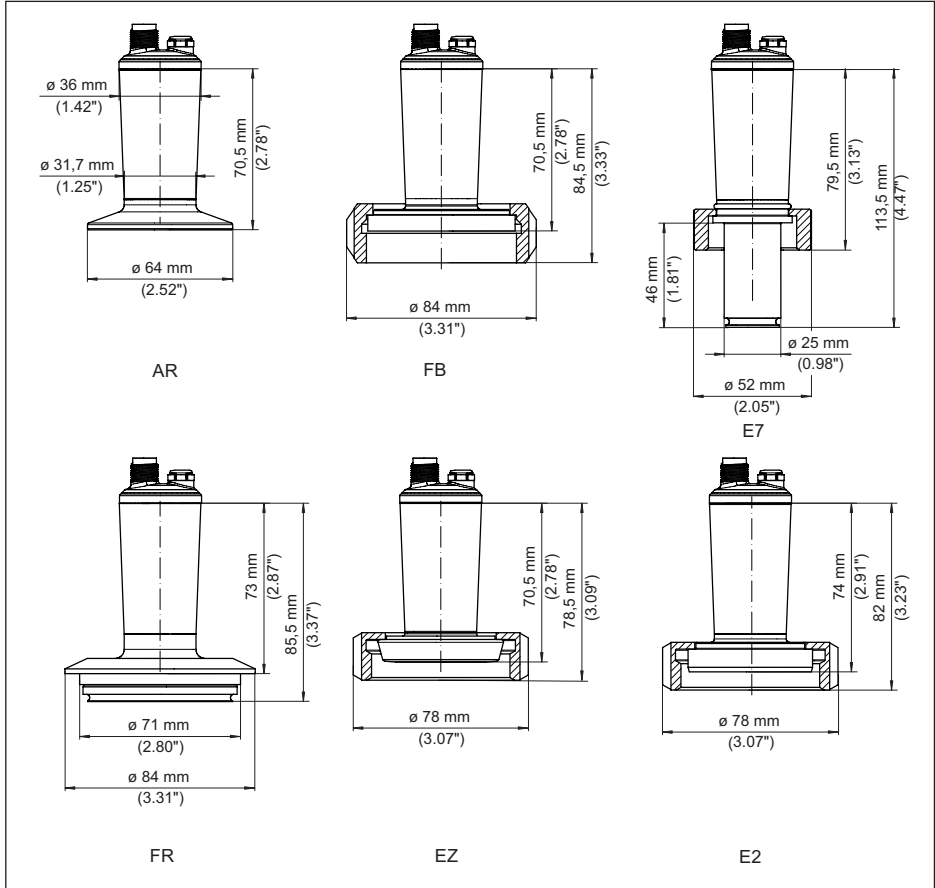

Fig. 34: VEGABAR 29, hygienic fitting

AR Clamp 2" PN 40,  $\varnothing 64$  mm (DIN 32676, ISO 2852)

FB SMS DN 51 PN 6

E7 Ingold connection PN 10

FR Varivent N50-40 PN 25

EZ Collar socket DN 40 PN 40 (DIN 11851)

E2 Collar socket DN 40 PN 40 (DIN 11864-1, Form A)

### 13.3 Industrial property rights

VEGA product lines are global protected by industrial property rights. Further information see [www.vega.com](http://www.vega.com).

VEGA Produktfamilien sind weltweit geschützt durch gewerbliche Schutzrechte.

Nähere Informationen unter [www.vega.com](http://www.vega.com).

Les lignes de produits VEGA sont globalement protégées par des droits de propriété intellectuelle. Pour plus d'informations, on pourra se référer au site [www.vega.com](http://www.vega.com).

VEGA líneas de productos están protegidas por los derechos en el campo de la propiedad industrial. Para mayor información revise la pagina web [www.vega.com](http://www.vega.com).

Линии продукции фирмы ВЕГА защищаются по всему миру правами на интеллектуальную собственность. Дальнейшую информацию смотрите на сайте [www.vega.com](http://www.vega.com).

VEGA系列产品在全球享有知识产权保护。

进一步信息请参见网站 < [www.vega.com](http://www.vega.com)。

### 13.4 Licensing information for open source software

Open source software components are also used in this device. A documentation of these components with the respective license type, the associated license texts, copyright notes and disclaimers can be found on our homepage.

### 13.5 Trademark

All the brands as well as trade and company names used are property of their lawful proprietor/originator.



57087-EN-210301

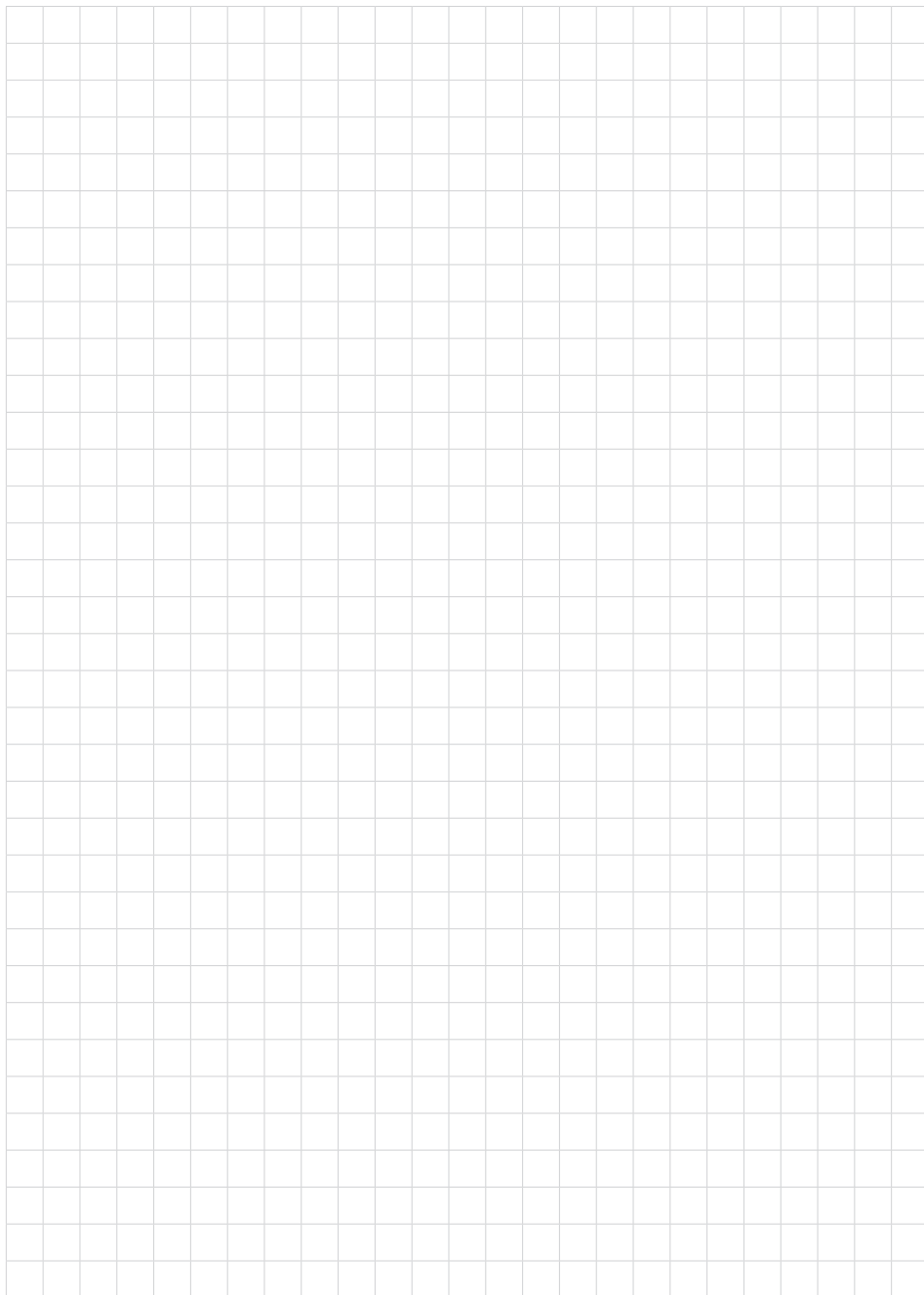



57087-EN-210301

Printing date:

**VEGA**

All statements concerning scope of delivery, application, practical use and operating conditions of the sensors and processing systems correspond to the information available at the time of printing.

Subject to change without prior notice

© VEGA Grieshaber KG, Schiltach/Germany 2021



57087-EN-210301

VEGA Grieshaber KG  
Am Hohenstein 113  
77761 Schiltach  
Germany

Phone +49 7836 50-0  
E-mail: [info.de@vega.com](mailto:info.de@vega.com)  
[www.vega.com](http://www.vega.com)