



OpreX™ Analyzers

## **FC800D**

Non-reagent Type Free Available Chlorine Sensor Unit

## **RC800D**

Reagent Type Residual Chlorine Sensor Unit

## **FLXA402T**

Liquid Analyzer for Turbidity and Chlorine

# Providing reliable chlorine measurements in Water Treatment Plants since 1959

No.1 Process analyzer supplier to Japanese market. (\*)

- Amperometric (Polarographic method) measurement of chlorine
- Unique rotating electrode method keeps sensor clean
- Easy maintenance structure
- Advanced sensor diagnostics
- Various communications are available
- Multiple detector/sensor connection
- Supports 8 languages
- Compliant with EPA Method 334.0 for Free Chlorine Measurement (FC800D)



(\*) Based on a Yokogawa survey in 2019

## Compact system

### Can connect max 2 sensors to one analyzer

Two non-reagent type free available chlorine sensor units can be connected to one analyzer. In addition, in stead of two chlorine sensor connection, you can connect turbidity detector, pH sensor or conductivity sensor in 2nd sensor module.



## Easy-to-operate display

### Excellent visibility and operability

Adopted color touch screen and you can operate intuitively. Errors are also displayed in color and you can easily understand whether your analyzer is normal or not.

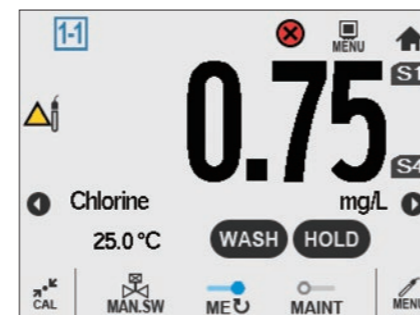

[Easy to use Touch screen]

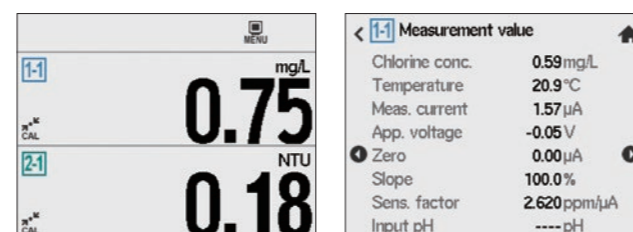

Divided display and easy to see

Advanced diagnostics functions helps your regular maintenance

## Unique rotating electrode method keeps sensor clean

Continuous automatic cleaning with beads ensures contamination resistance enabling long term stability

- 1 **Electrode Unit:** Built-in Motor, Rotating contact
- 2 **Smart unit:** Built-in Main board
- 3 **Rotating electrode:** Rotating electrode with beads keep the surface polished. This keeps the measurement electrode contaminant free providing long term stability.
- 4 **Reference electrode:** Built-in temperature sensor for temperature compensation
- 5 **Beads case:** Houses cleaning beads.
- 6 **Needle valve for flow rate adjustment** (only for FC800D)

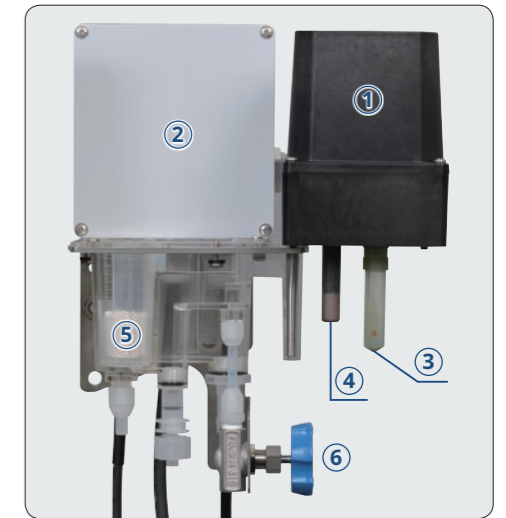

## No adjustment, just replace parts

### Adopts direct drive motor and new rotating contacts

All maintenance parts are very simple and no need to adjust after you replace parts. In addition, you can reduce maintenance time dramatically thanks to easy maintenance structures.

- Changed from brush and slip ring contact to rotating contact. Just replace this parts in new model.

- Changed from belt drive to direct drive between motor and measurement electrode shaft. No need to adjust belt tension anymore.

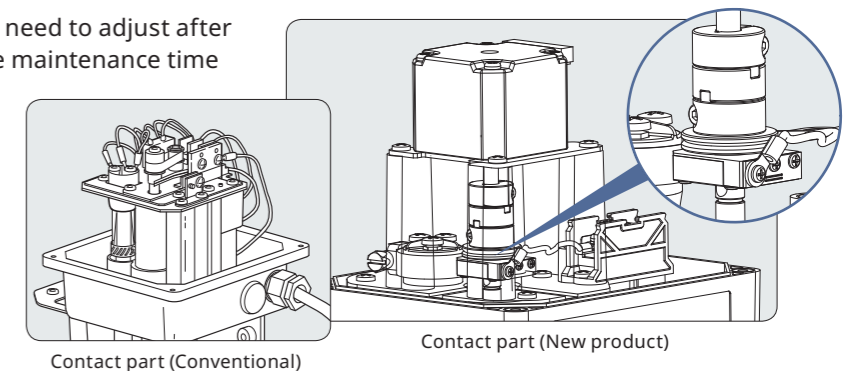

Contact part (Conventional)

Contact part (New product)

## SENCOM 4.0 platform for Turbidity and Chlorine Analyzer

### Remote operation made simple

SENCOM 4.0 platform empowers you. Digital technology gives you insight into field based problems. You can look into and understand causes before heading to site. This reduces maintenance time and increases efficiency.

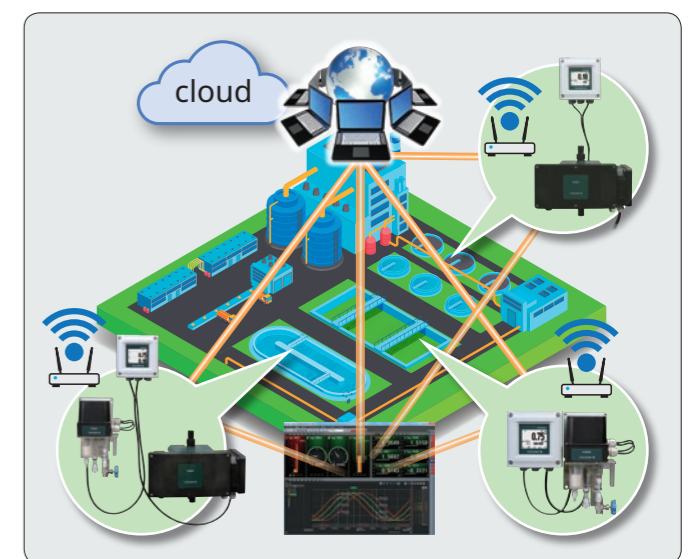

## Application of Chlorine Analyzer

Control of residual chlorine in sedimentation ponds and distribution mains at water treatment plant

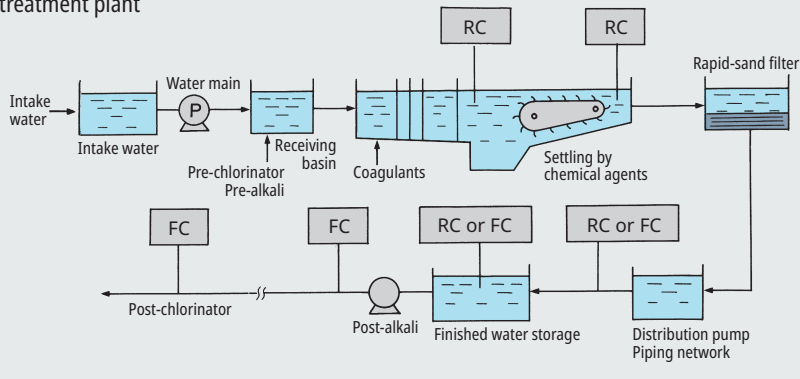

RC (Model RC800D) FC (Model FC800D)

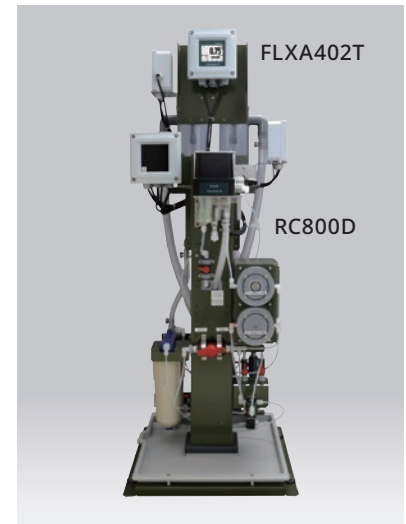

## Non-reagent and reagent type Chlorine Analyzer operating conditions comparison

Operating conditions	Non-reagent Type Free Available Chlorine Sensor Unit FC800D (-F1, -C1) (see *Note1)	Reagent Type Residual Chlorine Sensor Unit RC800D
Measurement	Free available chlorine	Free available chlorine, total chlorine
Sample pH	pH6.5 to 7.5 pH6.0 to 8.0 (-F1: Chlorine value ≤ 1 mg/L) (see *Note2)	pH 3 to 9
Allowable suspended solids in sample	10 mg/L max.	500 mg/L max.
Sample conductivity	100 to 300 μS/cm 100 to 500 μS/cm (-F1: Chlorine value ≤ 1 mg/L) (see *Note2)	No limit
When sample contains combined chlorine	Not suitable	Suitable (combined chlorine insensitive version)
Effect of combined chlorine on free chlorine measurement	Large (see *Note3)	Almost none
Where measurement accuracy is required	Suitable (but less suitable than RC800D)	Suitable
Application	Filtered water, treated water, distribution system, feed water, tap water	Each process at treatment plant: from reservoir to treated water, distribution system

(\*Note1) As for -F2 and -F3, please refer to General Specifications. (\*Note2) Under this condition and no fluctuation

(\*Note3) Because treated water, distributed water and tap water contain almost no combined chlorine, there is no problem found in applications.

### FLXA402T Liquid Analyzer for turbidity and chlorine

1st input	Chlorine	Diagnosis function	Motor rotation monitoring, empty cell detection, sensor condition check (zero point, Slope, stability during calibration)
2nd input	Chlorine, Turbidity, pH or Conductivity		
mA output	2 x 4-20 mA Output or 4 x 4-20 mA Output	Display	QVGA color LCD with a touch screen 8 languages (English, German, French, Chinese, Korean, Spanish, Portuguese, Japanese)
Communication	Modbus TCP/IP, Modbus RTU (RS485)		

Please refer to the general specifications for details.

It could be downloaded from the following site.

<https://www.yokogawa.com/an/flxa402t/download/>



### Trademarks

All brand or product names of Yokogawa Electric Corporation in this document are trademarks or registered trademarks of Yokogawa Electric Corporation. All other company brand or product names in this bulletin are trademarks or registered trademarks of their respective holders.

**YOKOGAWA ELECTRIC CORPORATION**  
World Headquarters

9-32, Nakacho 2-chome, Musashino-shi, Tokyo 180-8750, JAPAN

**YOKOGAWA CORPORATION OF AMERICA**  
**YOKOGAWA EUROPE B.V.**  
**YOKOGAWA ENGINEERING ASIA PTE. LTD.**  
**YOKOGAWA CHINA CO., LTD.**  
**YOKOGAWA MIDDLE EAST & AFRICA B.S.C.(c)**

<https://www.yokogawa.com/an/>

<https://www.yokogawa.com/us/>  
<https://www.yokogawa.com/eu/>  
<https://www.yokogawa.com/sg/>  
<https://www.yokogawa.com/cn/>  
<https://www.yokogawa.com/bh/>



Represented by:

ANA-02E

Subject to change without notice.

[Ed:02/b]

Printed in Japan, 409(KP)

All Rights Reserved, Copyright © 2021, Yokogawa Electric Corporation.