



FLOW-SMS

Surface Mount Sub-Systems
for Mass Flow / Pressure Meters and Controllers



› Introduction

Bronkhorst High-Tech B.V., the European market leader in Thermal Mass Flow Meters/Controllers and Electronic Pressure Controllers, has many years of experience in designing and manufacturing precise and reliable measurement and control devices. With a wide range of instruments, Bronkhorst offers innovative solutions for many different applications in a variety of different markets.

› FLOW-SMS series, compact assemblies of functional modules

Bronkhorst developed the FLOW-SMS series for customers who are looking for process gas panels with optimal space efficiency. On a compact, lightweight but still rugged mounting rail system one or more mass flow or pressure sensor modules can be combined with control valves, shut-off valves, mixing chambers, filters or any other functional module as per customer's request. The modular concept of the FLOW-SMS system offers great flexibility for the end-user with respect to modifications and serviceability. The functional modules are 'top-mount', so they can easily be exchanged without removing the total assembly.

The ranges for the flow meters and controllers can be selected between approx. 5 ml_r/min up to 50 l_r/min or even higher. In case a pressure meter or controller is included, the pressure range can be chosen between 0-100 mbar and 0-10 bar absolute or gauge. Depending on the application the customer may prefer a system with compression type couplings, face seal fittings or flanges according to customers' specification. On request, the system will be assembled, tested, and packaged in a cleanroom.

› Fields of application

The FLOW-SMS Series has great potential in many different markets, for instance in:

- ◆ Vacuum, plasma, sputter and coating processes
- ◆ Catalytical test benches
- ◆ Semiconductor and solar cell fabrication
- ◆ Burner control (welding)
- ◆ Biotechnological and chemical installations
- ◆ Food and beverage processes

› FLOW-SMS features

- ◆ Compact assembly ensures space efficiency and minimized dead volume
- ◆ Economical solution, low cost of ownership
- ◆ Tubeless construction reduces potential leak points
- ◆ Service friendly; easily accessible from the top
- ◆ Great flexibility regarding system extension or modification
- ◆ Pre-tested "Plug and Work" units, reducing custom testing requirements

› Digital features

- ◆ Fieldbus interfaces:
 - ◆ DeviceNet™, CANopen®
 - ◆ PROFIBUS DP, Modbus, FLOW-BUS
 - ◆ EtherCAT®, PROFINET, Modbus-TCP, EtherNet/IP, POWERLINK
- ◆ Optional PROFIBUS Gateway offering cost-effectiveness at 3 or more channels
- ◆ Alarm and counter functions
- ◆ Control characteristics user-configurable
- ◆ Optional Multi Gas / Multi Range functionality
- ◆ Free software tools



Example of a 3-channel FLOW-SMS with two gas flow controllers and one pressure controller



Example of a 6-channel FLOW-SMS solution with FLOW-BUS communication

› Technical specifications Mass Flow / Pressure Modules

MASS FLOW measurement / control modules

Accuracy (incl. linearity) (based on actual calibration)	standard: $\pm 0,5\%$ Rd plus $\pm 0,1\%$ FS; for ranges 3...5 ml _r /min: $\pm 1\%$ FS
Turndown	1 : 50 (in digital mode up to 1 : 187,5)
Repeatability	< 0,2% Rd
Settling time (controller)	1...2 seconds typical above 5% FS;
Control stability	< $\pm 0,1\%$ FS (typical for 1 l _r /min N ₂)
Max. operating pressure	10 bar gauge
Temperature sensitivity	zero < 0,05% FS/°C; span < 0,05% Rd/°C
Pressure sensitivity	0,1% Rd/bar typical N ₂ , 0,01% Rd/bar typical H ₂
Warm-up time	30 min. for optimum accuracy 2 min. for accuracy $\pm 2\%$ FS

PRESSURE measurement / control modules

Accuracy (incl. linearity)	$\pm 0,5\%$ of full scale (FS)
Pressure rangeability	Measurement 1 : 50 (2...100%) Control PS-602CV 1 : 20 (with flow range 1:50) PS-702CV 1 : 5
Repeatability	< 0,1% FS
Response time sensor	< 0,1 second
Control stability	< $\pm 0,1\%$ FS (typical for 1 l _r /min N ₂ at specified process volume)
Temperature sensitivity	0,1% FS/°C

General performance Mass Flow / Pressure modules

Operating temperature	-10...+50°C
Leak integrity (outboard)	tested < 2×10^{-9} mbar.l/s He
Leak-by through closed control valve	< 10^{-4} mbar.l/s He
Attitude sensitivity	may be mounted in any position

Mechanical parts

Material (wetted parts)	stainless steel 316L or comparable
Process connections	compression type or face seal couplings
Seals	standard Viton® options EPDM, FFKM (Kalrez)
Ingress protection (housing)	IP40

Electrical properties

Power supply	+15...24 Vdc
Power consumption	meter max. 125 mA; controller max. 320 mA; add max. 75 mA for fieldbus, if applicable
Analog output	0...5 (10) Vdc, min. load impedance > 2 kΩ; 0 (4)...20 mA (sourcing), max. load impedance < 375 Ω
Analog setpoint	0...5 (10) Vdc, min. load impedance > 100 kΩ; 0 (4)...20 mA, load impedance ~ 250 Ω
Digital communication	standard: RS232 options: CANopen®, DeviceNet™, EtherCAT®, PROFIBUS DP, PROFINET, Modbus RTU, ASCII or TCP/IP, EtherNet/IP, POWERLINK, FLOW-BUS

Electrical connection

Analog / RS232	9-pin D-connector (male);
PROFIBUS®DP	bus 9-pin D-connector (female) power 9-pin D-connector (male)
DeviceNet™, CANopen®	5-pin M12-connector (male)
FLOW-BUS, Modbus-RTU/ASCII	RJ45 modular jack
Modbus-TCP, EtherNet/IP, POWERLINK, EtherCAT®, PROFINET	2x RJ45 modular jack

Notes:

- ◆ Mass flow units ml_r/min and l_r/min refer to 0°C (32°F) and 1013 mbar (14.7 psi)
- ◆ For 3 or more PROFIBUS channels we advise to use our Gateway module
- ◆ Technical specifications subject to change without notice.
- ◆ For dimensional drawings see the downloads section at www.bronkhorst.com

› Models and ranges

Mass Flow Meters (MFM); ranges based on N₂

Model	min. flow	max. flow
FS-100C	0,06...3 ml _r /min	0,18...9 ml _r /min
FS-101C	0,16...8 ml _r /min	0,2...10 l _r /min
FS-102C	0,08...4 l _r /min	1...50 l _r /min

Mass Flow Controllers (MFC)

Model	min. flow	max. flow
FS-200CV ¹⁾	0,06...3 ml _r /min	0,18...9 ml _r /min
FS-201CV ¹⁾	0,16...8 ml _r /min	0,2...10 l _r /min
FS-202CV ¹⁾	0,08...4 l _r /min	1...50 l _r /min

Electronic Pressure Transducers (EPT)

Model	min. pressure	max. pressure
PS-502C	2...100 mbar ²⁾	0,2...10 bar ²⁾

Electronic Pressure Controllers (EPC)

Model	min. pressure	max. pressure
PS-602CV ¹⁾ (forward pressure control)	5...100 mbar ²⁾	0,5...10 bar ²⁾
PS-702CV ¹⁾ (back pressure control)	20...100 mbar ²⁾	2...10 bar ²⁾

¹⁾ $K_v\text{-max} = 6,6 \times 10^{-2}$

²⁾ Absolute or relative (gauge)



Example of an 8-channel FLOW-SMS system with PROFIBUS Gateway

FUNCTIONAL MODULES

› Mass flow meters / controllers

The mass flow sensor operates on a principle of heat transfer by sensing the temperature difference along a heated section of a capillary tube. Part of the total flow is forced through the capillary by means of a laminar flow element in the main stream generating a pressure difference. The design of the laminar flow device is such that flow conditions in both the capillary and laminar flow device are comparable, thereby resulting in proportional flow rates through the meter. The ΔT sensed by the upstream and downstream temperature sensors on the capillary depends on the amount of heat absorbed by the gas flow. The control valve used in the FLOW-SMS series is a standard, direct operated solenoid valve (normally opened or normally closed), operated through the PID-control function on the pc-board of the flow or pressure meter. The orifice diameter is optimised for the customer's specification.



› Pressure meters / controllers

FLOW-SMS pressure meters/controllers range from 100 mbar up to 10 bar, measuring either absolute pressure or gauge pressure, with a very high accuracy and repeatability. The instruments are equipped with a diaphragm based piezo-resistive sensor. Pressure controllers are available as forward controller (PS-600 series) and backward controller (PS-700 series). The flow going through the pressure controller depends on up and downstream pressures, orifice diameter of the valve and the density of the fluid.



› Filter modules

To protect the instruments from particles it is possible to integrated filter modules in your FLOW-SMS system.

Pore sizes	0,5 – 2 – 7 – 15 micron
------------	-------------------------



› Solenoid operated shut off valves

Solenoid-operated shut off valves are available in Normally Closed (NC) and Normally Opened (NO) configuration. A spring action opens or closes the valve instantly when it is either energized or de-energized. Solenoid shut off valves are applied to offer extra safety in case of system failure or to reduce the leak-by rates in the system.

Supply voltage	+ 24Vdc
Power consumption	3 Watt
Max. ΔP	3 bar dif.
Kv-max.	0,065



› Pneumatic operated shut off valves and 3/2 valves

Similar to the solenoid valves mentioned above, pneumatic operated shut off valves are available in Normally Closed (NC) and Normally Opened (NO) configuration. The 2/2-way shut off valves can be supplied with optional feedback sensor.

Actuation pressure	3...9 barg (2/2-way shut off) or 4...9 barg (3/2-way valve)
Kv-max	0,2 (2/2-way and NC 3/2-way); 0,085 (NO 3/2-way)



› Toggle valves

These valves can be used for quick acting and positive on/off control.

Kv-max.	0,09
---------	------



› Needle valves

Needle valves may be used in flow metering applications, e.g. when a constant, low flow rate must be maintained for some time. Various Kv-ranges



MANIFOLD COMPONENTS

The functional modules described on the previous page are mounted on a modular manifold assembly, consisting of support rails, base bodies, distribution and mixing chambers and adapter or blind plates.

› Support rails

Each FLOW-SMS system is supported by two mounting rails, which also provide panel mounting capability for the total system. There are support rail sets for 3 up to 9 channels available.

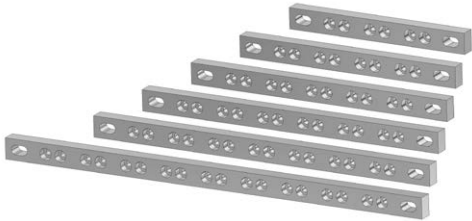

› Base bodies

Two types of base bodies provide support for the functional modules. There is one size for meters/controllers and another for filter modules and valves.



› Distribution and mixing chambers

A distribution chamber at the front end of a FLOW-SMS system provides the ability to distribute one or more gases among a number of flow paths. At the downstream side, mixing chambers can be integrated to combine the outputs of various flow channels. Please note that the maximum flow capacity for distribution or mixing chambers is 50 l_v/min air-equivalent (or 70 l_v/min Hz/He).



› Adapter plates and blind plates

The compression type (1/8" / 1/4" / 6 mm) or 1/4" face seal adapter plates are designed to bolt on to the inlets and outlets of base bodies and distribution/mixing chambers. Blind plates provide a cover for unused in- and outlets of distribution and mixing chambers.

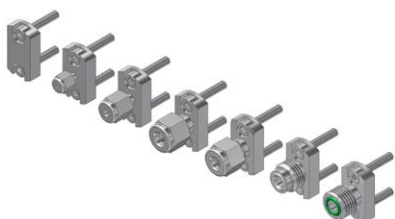

› Configuration software tool

Because of the infinite number of possible solutions, we recommend you to contact our nearest distributor to discuss your application. With the online FLOW-SMS configuration software Bronkhorst assists you designing your bespoke FLOW-SMS system by arranging functional modules viz. flow or pressure meters/controllers, valves and filters in combination with mixing chambers, adapter plates, mounting rails, etc. (see below example).

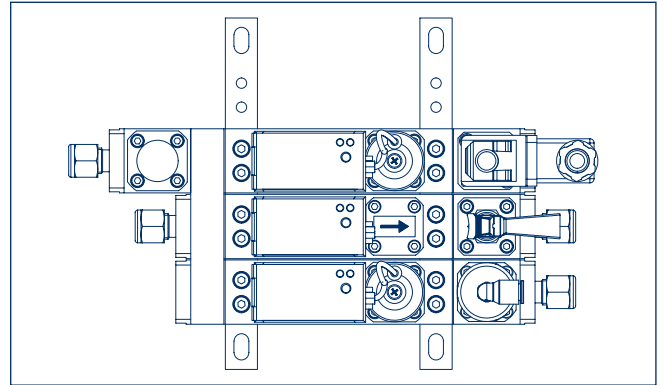

Top View

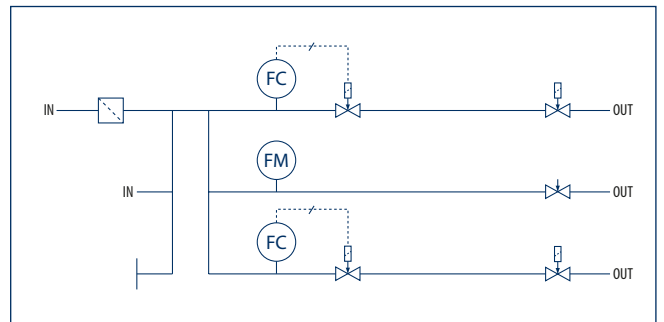

Flow View



www.bronkhorst.com

Bronkhorst High-Tech designs and manufactures innovative instruments and subsystems for low-flow measurement and control for use in laboratories, machinery and industry. Driven by a strong sense of sustainability and with many years of experience, we offer an extensive range of (mass) flow meters and controllers for gases and liquids, based on thermal, Coriolis and ultrasonic measuring principles. Our global sales and service network provides local support in more than 40 countries. Discover Bronkhorst®!

Bronkhorst High-Tech B.V.
Nijverheidsstraat 1a
NL-7261 AK Ruurlo, The Netherlands

Tel. +31 573 458800
info@bronkhorst.com



9.60.039D P2000269 ©Bronkhorst*