



OpreX™ Analyzer

SENCOM 4.0 solution for water industry

Smart Turbidity & Chlorine Analyzers

Reliable and smart water management system

Since sales began in 1959, Yokogawa's has continuously developed and improved the turbidity and free chlorine meters using various principles suited for multiple applications. Yokogawa has earned its customers confidence focusing on accuracy, reliability, and serviceability with its many achievements.

Building on this experience, Yokogawa has developed a new analyzer solutions platform featuring superior measurement technology to deliver enhanced value throughout the product lifecycle.



Simplified selection

The FLXA series is one analyzer that can measure multiple measurements simultaneously, assisting with reducing CAPEX and OPEX.



Expert guide

The intuitive menu structure, along with easy-to-understand alarm settings and detailed troubleshooting information, contributes to your online process control measurements' credibility and reliability.



Process guard

Real-time diagnostics and consumable parts lifetime monitoring predicts next maintenance and consumable parts replacement for pro-active maintenance



Maintenance manager

Regular maintenance and calibration in the field can easily take half an hour per measurement monthly or bi-weekly. Automatic zero calibration function washes measurement cell and calibrate automatically on the scheduled time. In addition, the SENCOM 4.0 platform utilizes the "plug and play" function and no need to adjust analyzers on the field, and it will significantly decrease downtime while increasing measurement integrity.



Advanced flexibility

The FLXA402T dual-channel unit can mix and match measurement parameters with turbidity, chlorine, pH, or conductivity. With Turbidity/Chlorine's addition into the SMART Sensor Platform, "Smart City" can be achieved with one "small water monitoring system."



Data Mobility

Accelerates time-to-value of new technology and provides the flexibility, simplicity, and efficiency to move data and workloads seamlessly on an ongoing basis.

Yokogawa's next-generation Turbidity and Chlorine analyzer for smart city

To facilitate optimal processes and improve personnel efficiency, Yokogawa has placed a strong focus on our Digital SMART Sensor SENCOM 4.0 Platform. This innovative analyzer platform provides full visualization and enhanced process uptime by optimizing maintenance, reducing configuration time, and simplifying in-field maintenance and calibration.

Sustainable Water Cycle by smart city system

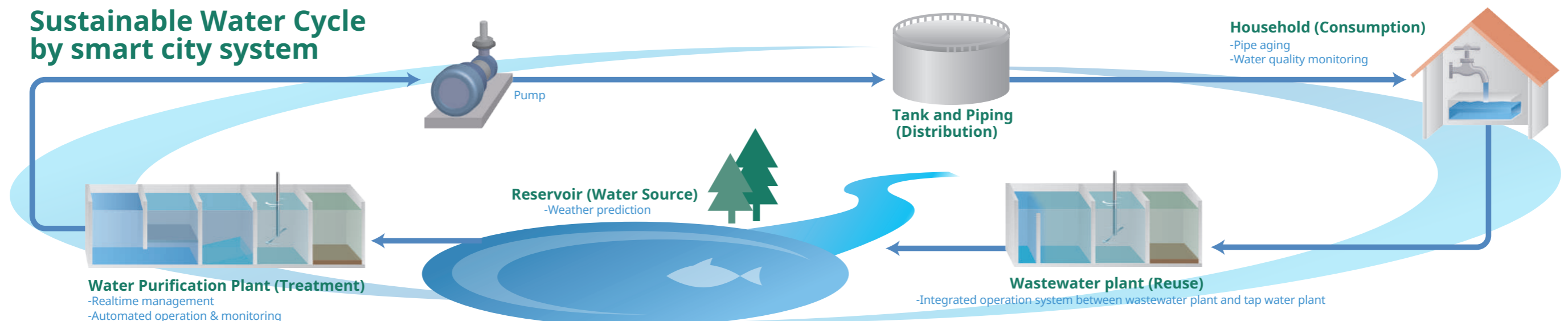

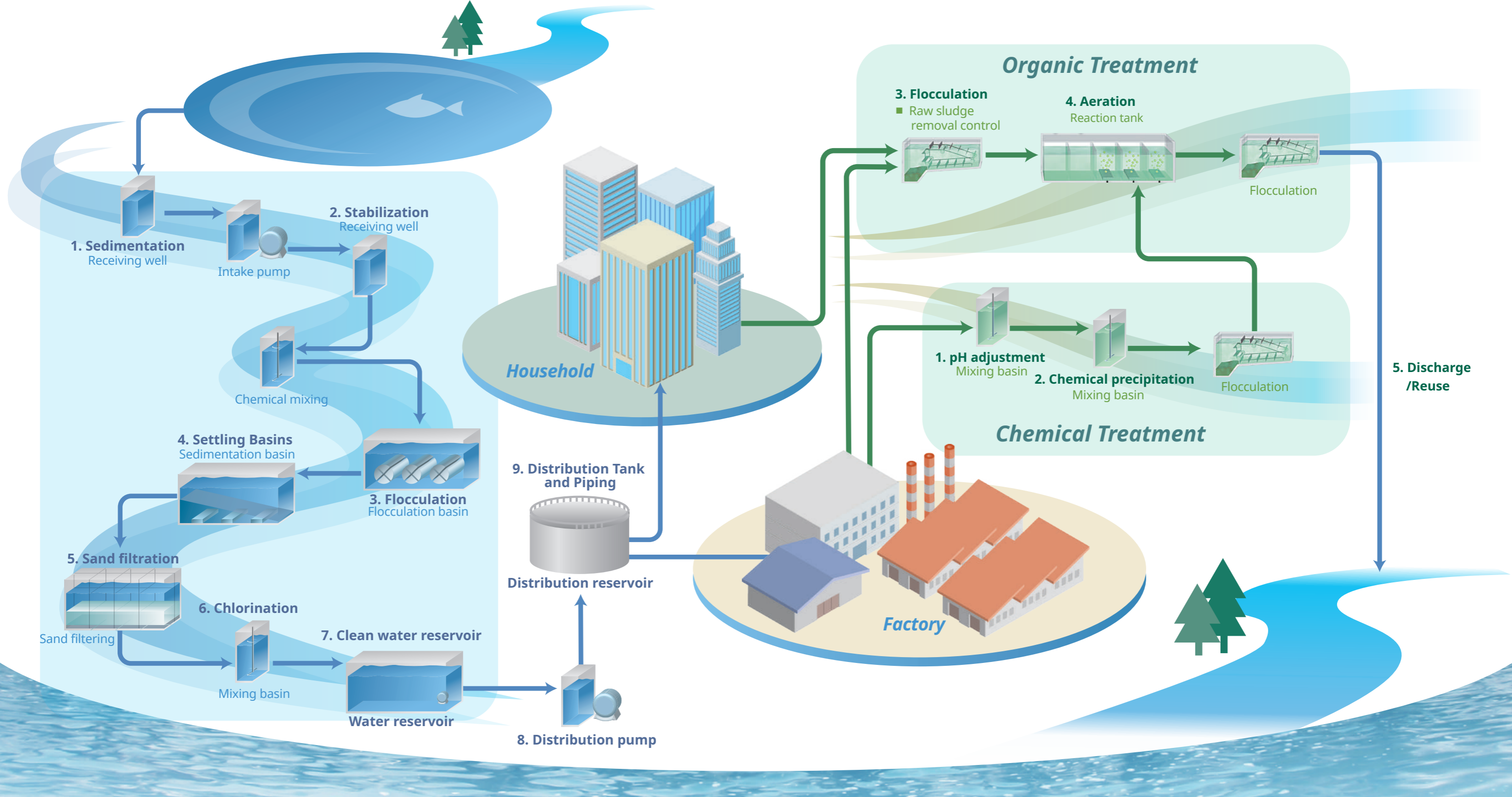

Water Purification Treatment

1. Sedimentation	pH, Conductivity Turbidity
2. Stabilization	pH, Chlorine
3. Flocculation	pH, Turbidity, Chlorine
4. Settling Basins	pH, Turbidity, Chlorine
5. Sand filtration	Turbidity, Chlorine
6. Chlorination	Chlorine
7. Clean water reservoir	pH, Turbidity, Chlorine
8. Distributing pump	pH, Turbidity, Chlorine
9. Distribution tank and Piping	pH, Turbidity, Chlorine, Pressure, Temperature

Wastewater Treatment

1. pH adjustment	pH, ORP
2. Chemical precipitation	pH
3. Flocculation	pH
4. Aeration	DO, MLSS
5. Discharge/Reuse	pH, Turbidity, Chlorine, Flow

SENCOM4.0 Platform for Smart water supplying system

Liquid Analyzer for Turbidity and Chlorine FLXA402T

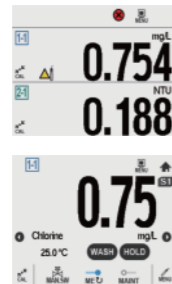

- Color touch LCD display
- Short cut menu for regular maintenance
- Multi sensor input from Turbidity, Chlorine, pH and conductivity
- Intelligence Diagnostics function
- Various communications
- 8 languages are available

Right Angle Scattered Light Turbidity Detector TB820D

- Easy Clean Structure
- LED light source
- No metal wetted parts
- Remote/Automatic range switching
- Ultrasonic Cleaning
- Remote/Automatic calibration and wash are available
- Air denoising function

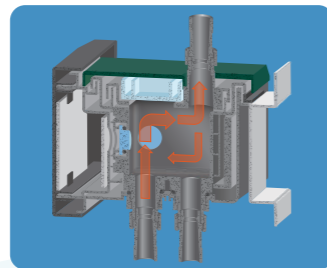

Flash window structure



Surface Scattering Light Turbidity Detector TB830D



Detect surface scattering

- Sensor does not contact to sample
- LED light source
- Can measure High turbidity
- Equipped Heater to avoid condensation
- Remote/Automatic range switching
- Automatic wash is available

Non-reagent Type Free Available Chlorine Sensor Unit FC800D



Maintenance Position

- Amperometric measurement of free chlorine (polarographic method)
- No reagent measurement
- Electrode continuously clean with beads
- Remote/Automatic range switching
- Remote/Automatic calibration and wash are available

Reagent Type Residual Chlorine Sensor Unit RC800D

- Amperometric measurement of free chlorine or total chlorine (polarographic method)
- High accuracy and can use wide applications
- Electrode continuously clean with beads
- Remote/Automatic range switching
- Remote/Automatic calibration and wash are available
- All measurement system is integrated



Turbidity Typical System configuration

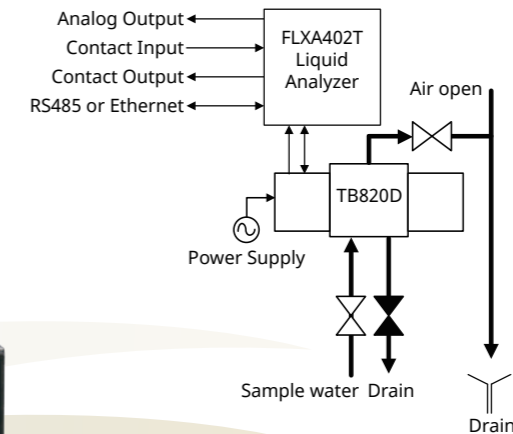

Chlorine Typical System configuration

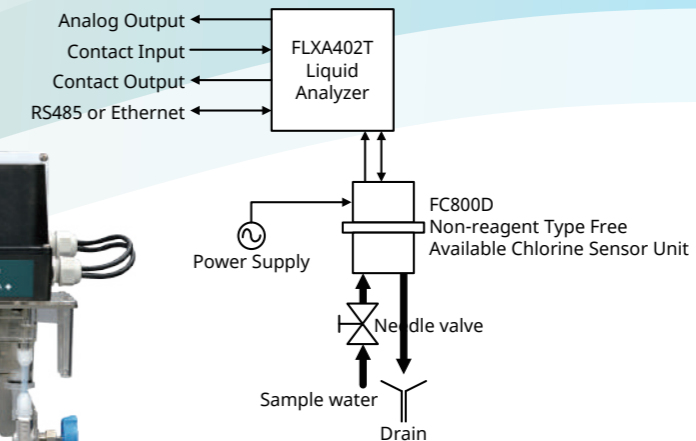

Chlorine and Turbidity 2 in 1 System configuration

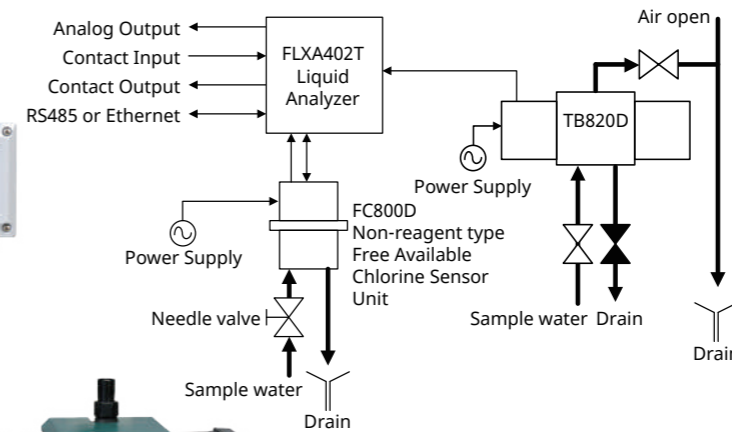
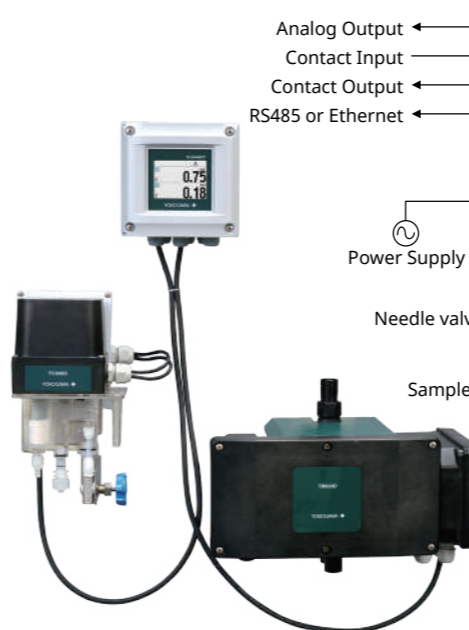

YOKOGAWA Global Sales & Service Network

North America

- United States
Yokogawa Corporation of America
- Canada
Yokogawa Canada, Inc.
- Mexico
Yokogawa de Mexico, S.A. de C.V.

South America

- Brazil
Yokogawa America do Sul Ltda.
- Colombia
Yokogawa Colombia S.A.S

Europe

- Netherlands
Yokogawa Europe B.V.
- Austria
Yokogawa GesmbH
Central East Europe
- Czech Republic
Yokogawa Europe B.V.
- Belgium
Yokogawa Belgium N.V./S.A.
- France
Yokogawa France S.A.S.
- Germany
Yokogawa Deutschland GmbH
- Hungary
Yokogawa Hungaria Kft.
- Italy
Yokogawa Italia S.r.l.
- Poland
Yokogawa Polska Sp.zo.o
- Spain
Yokogawa Iberia S.A.
- Turkey
Yokogawa Turkey Industrial
Automation Solutions A.S.
- United Kingdom
Yokogawa United Kingdom Limited
- Norway
Yokogawa TechInvent AS

Africa

- South Africa
Yokogawa South Africa (Pty) Ltd.
- Nigeria
Yokogawa Nigeria Limited

CIS

- Russia
Yokogawa Electric CIS Ltd.
- Kazakhstan
Yokogawa Electric Kazakhstan Ltd.
- Ukraine
Yokogawa Electric Ukraine Ltd.

Middle East

- Bahrain
Yokogawa Middle East
& Africa B.S.C. (c)
- Saudi Arabia
Yokogawa Saudi Arabia Ltd.
- United Arab Emirates
Yokogawa Engineering Middle East
& Africa FZE
- Oman
Yokogawa Oman Limited Liability
Company

Asia

- Singapore
Yokogawa Electric International
Pte. Ltd.
Yokogawa Engineering Asia Pte. Ltd.
- Indonesia
P.T. Yokogawa Indonesia
- Malaysia
Yokogawa Electric
(Malaysia) Sdn. Bhd
- Philippines
Yokogawa Philippines Inc.
- Thailand
Yokogawa (Thailand) Ltd.
- Vietnam
Yokogawa Vietnam Company Ltd.
- India
Yokogawa India Ltd.
- China
Yokogawa China Co., Ltd.
- Korea
Yokogawa Electric Korea Co., Ltd.
- Taiwan
Yokogawa Taiwan Corporation

Oceania

- Australia
Yokogawa Australia Pty. Ltd.
- New Zealand
Yokogawa New Zealand Limite

Japan

- Yokogawa Electric Corporation
- Yokogawa Solution Service Corporation
- Yokogawa Test & Measurement Corporation
etc.

OpreX™

Yokogawa achieves operational excellence by providing products, services, and solutions based on the OpreX comprehensive brand that cover everything from business management to operations.

Trademarks

All brand or product names of Yokogawa Electric Corporation in this document are trademarks or registered trademarks of Yokogawa Electric Corporation. All other company brand or product names in this bulletin are trademarks or registered trademarks of their respective holders.

YOKOGAWA ELECTRIC CORPORATION

World Headquarters

9-32, Nakacho 2-chome, Musashino-shi, Tokyo 180-8750, JAPAN

<https://www.yokogawa.com/an/>

YOKOGAWA CORPORATION OF AMERICA

YOKOGAWA EUROPE B.V.

YOKOGAWA ENGINEERING ASIA PTE. LTD.

YOKOGAWA CHINA CO., LTD.

YOKOGAWA MIDDLE EAST & AFRICA B.S.C.(c)

<https://www.yokogawa.com/us/>

<https://www.yokogawa.com/eu/>

<https://www.yokogawa.com/sg/>

<https://www.yokogawa.com/cn/>

<https://www.yokogawa.com/bh/>

Represented by:

ANA-01E

Subject to change without notice.

All Rights Reserved. Copyright © 2018, Yokogawa Electric Corporation.

[Ed:02/b]

Printed in Japan,205(HT)

YOKOGAWA



Co-innovating tomorrow™