

Product information

Capacitive

Level detection with bulk solids

VEGACAP 62

VEGACAP 65

VEGACAP 66

VEGACAP 67



Contents

1 Description of the measuring principle 3

2 Type overview 5

3 Housing overview 7

4 Mounting instructions 8

5 Electrical connection 11

6 Adjustment 13

7 Dimensions 14

Take note of safety instructions for Ex applications



Please note the Ex specific safety information that you can find at www.vega.com and that comes with each instrument. In hazardous areas you should take note of the appropriate regulations, conformity and type approval certificates of the sensors and power supply units. The sensors must only be operated on intrinsically safe circuits. The permissible electrical values are stated in the certificate.

1 Description of the measuring principle

Measuring principle

The VEGACAP series consists of capacitive sensors for level detection. The instruments are designed for industrial use in all areas of process technology and are universally applicable. Probe, measured product and vessel wall form an electrical capacitor. The capacitance is influenced by three main factors.

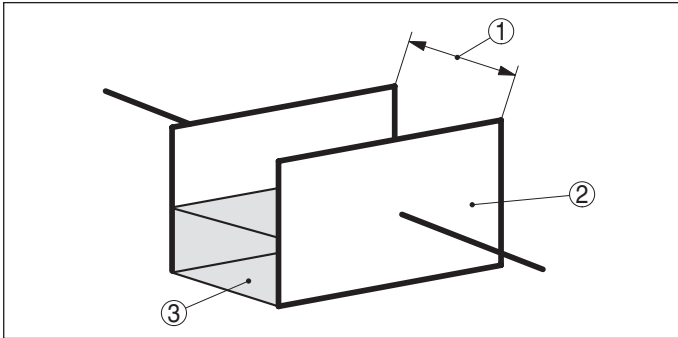

Fig. 1: Functional principle - Plate capacitor

- 1 Distance between the electrode surfaces
- 2 Size of the electrode surfaces
- 3 Type of dielectric between the electrodes

The probe and the vessel wall are the capacitor plates. The measured product is the dielectric. Due to the higher dielectric constant of the product compared to air, the capacitance increases as the probe is gradually covered.

A level change causes a change in capacitance which is processed by the electronics and converted into an appropriate switching command.

The more constant the conductivity, bulk density and temperature of a product, the better the conditions for capacitive measurement. Changes in the measuring conditions are generally less critical when detecting materials with high dielectric value.

The sensors are maintenance free and rugged and can be implemented in all areas of industrial measurement engineering.

Whereas fully insulated versions are predominantly used for liquids, partly insulated versions are preferred for solids.

Implementation in very adhesive or corrosive products is also no problem. Since the capacitive measuring principle places no special requirements on mounting, a host of different applications can be equipped with VEGACAP series 60 level switches.

1.2 Application examples

Light-weight solids

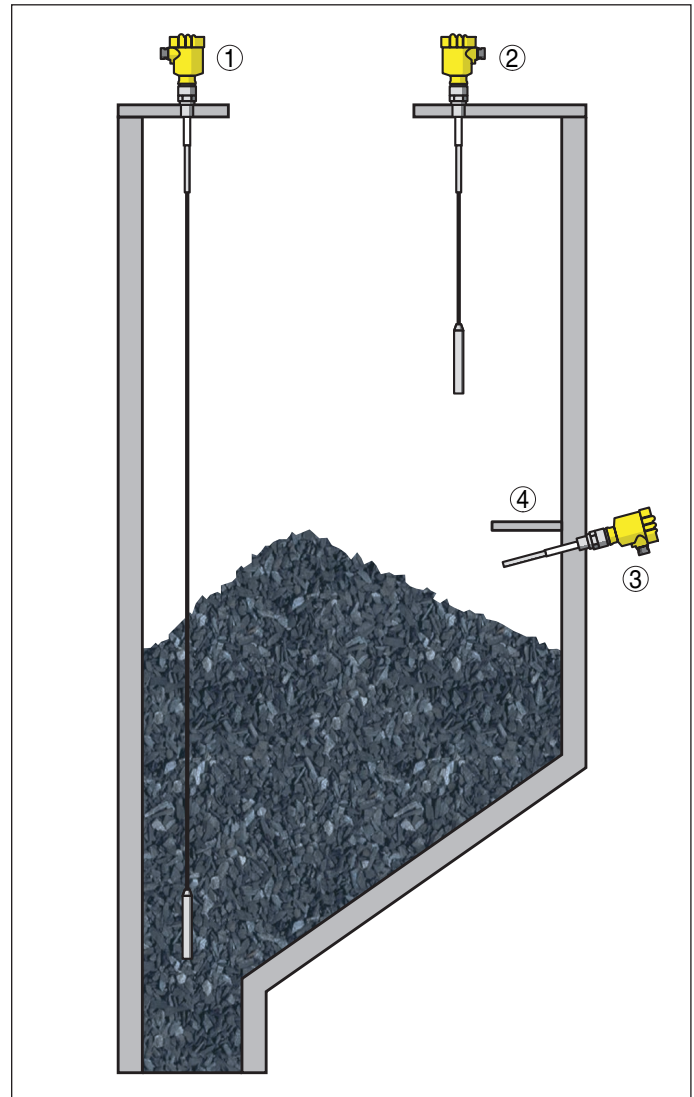

Fig. 2: Level switches in light solids

- 1 VEGACAP 65 level switch for empty signalling
- 2 VEGACAP 65 level switch for full signalling/overflow protection
- 3 VEGACAP 62 level switch for level detection - laterally mounted
- 4 Protective cover above the probe

Cable probes should generally be preferred over rod probes for use in bulk solids. Cable probes can follow the movements of the bulk material and thus have a considerably longer service life in abrasive and highly agitated bulk solids. The switching point is usually on the gravity weight, which provides very high measuring sensitivity due to its larger surface. This is especially advantageous for products with small dielectric value.

If the level detector has to be mounted laterally, a VEGACAP 65 cable probe or a VEGACAP 62 rod probe can be used. Due to the lateral mounting, VEGACAP 62 yields very high switching accuracy even if the product characteristics are constantly changing. The instrument should be mounted slightly inclined (approx. 20 ... 30°) to avoid possible buildup. Depending on the vessel height and position of the filling stream, VEGACAP 62 should be protected from mechanical impact with a protective cover.

If there is heavy condensation on the vessel ceiling, and thus on the measuring probe, a protective tube approx. 300 mm long should be applied.

Advantages:

- Shortenable probe
- Insensitive to buildup
- Simple setup
- Rugged construction

Heavy solids

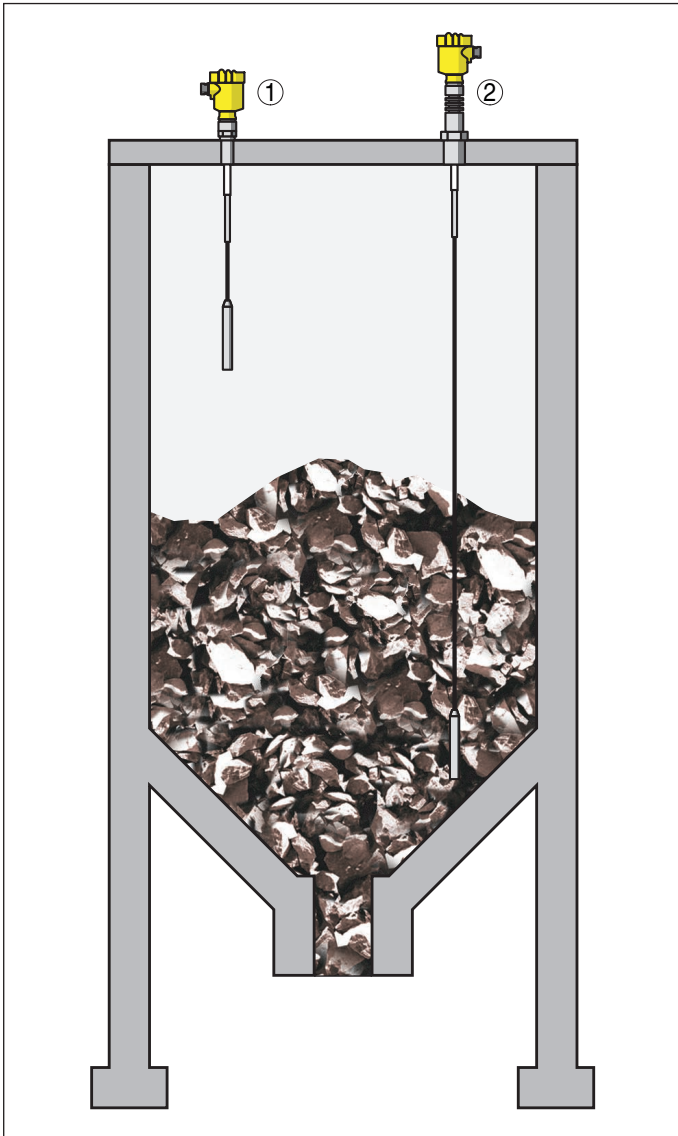

Fig. 3: Level switch in heavy solids

- 1 VEGACAP 65 level switch for full signalling/overflow protection
- 2 VEGACAP 65 level switch for empty signalling

Typical heavy solids are e.g. cement, sand, filler, gravel or flour.

Cable probes should be preferred over rod probes, especially for use in very heavy bulk materials. Cable probes can follow the movements of bulk material and thus have a considerably longer service life in abrasive and highly agitated bulk solids.

Ruggedness is very important for applications in heavy solids. The capacitive measuring principle lends itself well here. VEGACAP excels in such applications because of its robust mechanical construction and easy setup and commissioning.

Advantages:

- Very rugged construction
- Simple setup
- Shortenable probe
- Insensitive to buildup

Backup detection

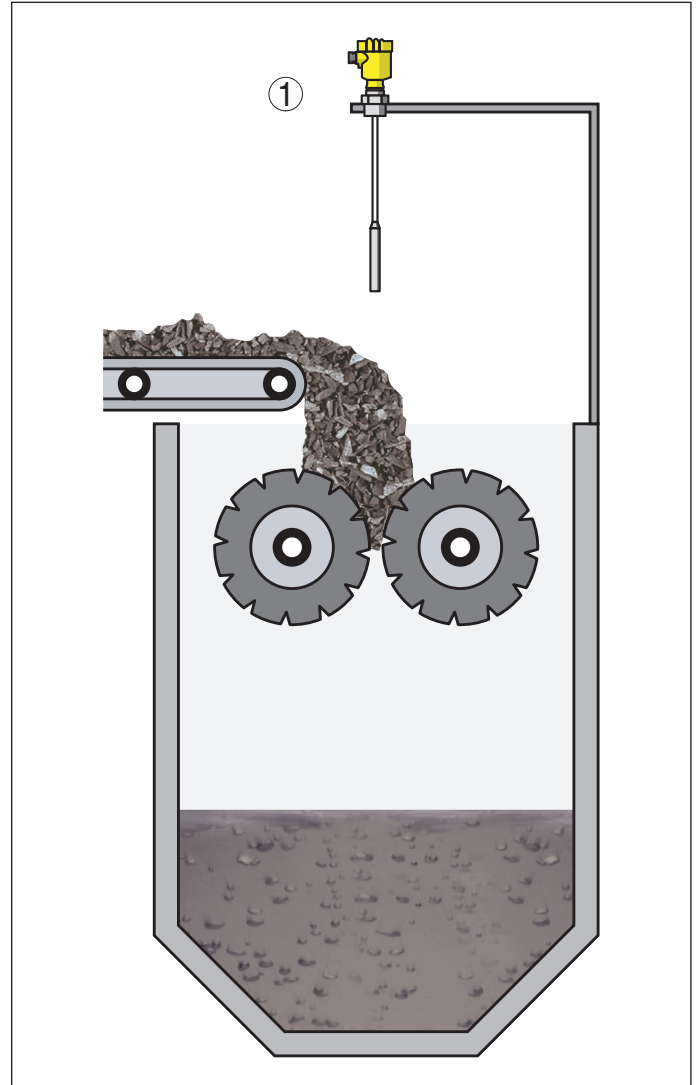

Fig. 4: Backup detection on conveyor belt/inlet funnel

- 1 VEGACAP 65 level switch for full signalling/overflow protection

Bulk solids reach the inlet funnel or buffer vessel via belt or spiral conveyors. The VEGACAP capacitive probe signals and prevents a possible backup or an overflowing of the inlet funnel. Depending on the temperature and kind of bulk material, steam or dust may be generated in the buffer vessel. VEGACAP is not affected by this and continues to function reliably.

The flexible suspension cable avoids excessive mechanical loads caused by movements of the bulk material.

In solids with a low dielectric value, lateral installation is recommended - a horizontally mounted rod gets covered quickly over its entire length and thus provides much more reliable switching. A suitable guard plate should be mounted above the rod of the probe to protect it against damage from falling solids. If the rod is mounted slightly inclined to the bottom, buildup can slide off more easily. The bulk material should not be too coarse or heavy.

Advantages:

- Simple mounting
- Wide application range
- Very rugged construction
- Maintenance-free

2 Type overview

VEGACAP 62



VEGACAP 65



VEGACAP 66



Preferred applications	Solids, non-conductive liquids	Solids, non-conductive liquids	Solids, liquids
Version	Rod - partly insulated	Cable - partly insulated	Cable - insulated
Insulation	PTFE	PA	PTFE
Length	0.2 ... 6 m (0.656 ... 19.69 ft)	0.4 ... 32 m (1.312 ... 104.99 ft)	0.4 ... 32 m (1.312 ... 104.99 ft)
Process fitting	Thread from G $\frac{3}{4}$, flanges	Thread from G1, flanges	Thread from G $\frac{3}{4}$, flanges
Process temperature	-50 ... +200 °C (-58 ... +392 °F)	-50 ... +200 °C (-58 ... +392 °F)	-50 ... +150 °C (-58 ... +302 °F)
Process pressure	-1 ... 64 bar/-100 ... 6400 kPa (-14.5 ... 928 psig)	-1 ... 64 bar/-100 ... 6400 kPa (-14.5 ... 928 psig)	-1 ... 40 bar/-100 ... 4000 kPa (-14.5 ... 580 psig)

VEGACAP 67





Preferred applications	Bulk solids under high temperatures
Version	Rod - partly insulated, cable - partly insulated
Insulation	Ceramic
Length	Rod: 0.28 ... 6 m (0.919 ... 19.69 ft) Cable: 0.5 ... 40 m (1.64 ... 131.23 ft)
Process fitting	Thread from G1½
Process temperature	-50 ... +400 °C (-58 ... +752 °F)
Process pressure	-1 ... 16 bar/-100 ... 1600 kPa (-14.5 ... 232 psig)

3 Housing overview

Plastic PBT	
Protection rating	IP 66/IP 67
Version	Single chamber
Application area	Industrial environment

Aluminium	
Protection rating	IP 66/IP 67, IP 66/IP 68 (1 bar)
Version	Single chamber
Application area	Industrial environment with increased mechanical stress

Stainless steel 316L		
Protection rating	IP 66/IP 67	IP 66/IP 67, IP 66/IP 68 (1 bar)
Version	Single chamber, electropolished	Single chamber, precision casting
Application area	Aggressive environment, food processing, pharmaceutical	Aggressive environment, extreme mechanical stress

4 Mounting instructions

Switching point

VEGACAP can be mounted in any position.

In case of horizontal installation, the instrument must be mounted in such a way that the probe is at the height of the requested switching point.

In case of vertical installation, the instrument must be mounted so that the probe is immersed approx. 50 ... 100 mm in the product when the desired switching point is reached.

Mounting socket

In adhesive products, the probe should protrude into the vessel (horizontal mounting), to avoid buildup. In such cases, avoid sockets for flanges and threaded fittings.

Filling opening

Install the meas. probe in such a way that the probe does not protrude directly into the filling stream. Should such an installation location be necessary, mount a suitable baffle above or in front of the probe.

Horizontal installation

To achieve a very precise switching point, you can install VEGACAP horizontally. However, if the switching point can have a tolerance of a few centimeters, we recommend mounting VEGACAP approx. 20° inclined to the vessel bottom to avoid buildup.

Install rod probes in such a way that the probe projects freely into the vessel. When the instrument is mounted in a tube or socket, buildup can form which impairs the measurement. This applies mainly to adhesive products.

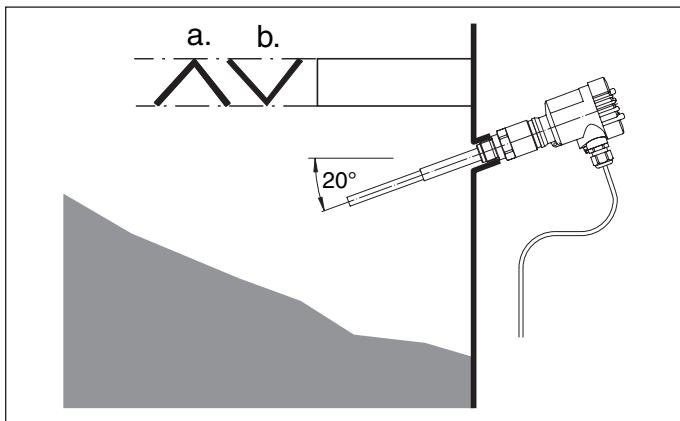

Fig. 13: Horizontal installation

Material cone

Material cones can form in silos containing bulk solids, thereby altering the switching point. Please keep this in mind when installing the probe in the vessel. We recommend selecting an installation location where the probe detects an average value of the material cone.

The probe must be mounted in a way that takes the arrangement of the filling and emptying apertures into account.

To compensate the measuring error caused by the material cone in cylindrical vessels, the probe must be mounted at a distance of $d/6$ from the vessel wall.

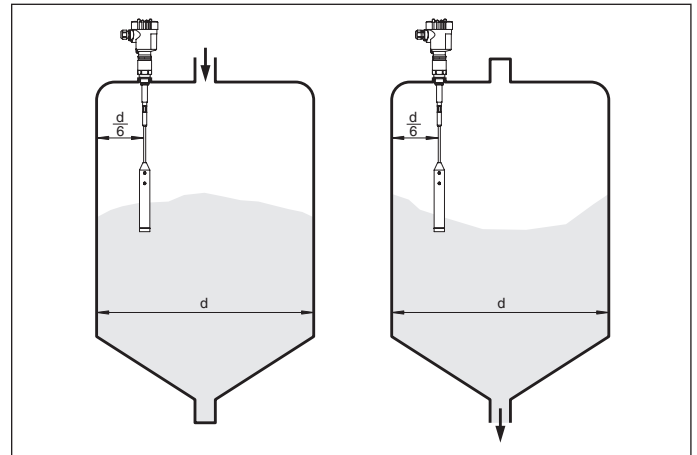

Fig. 14: Filling and emptying centred

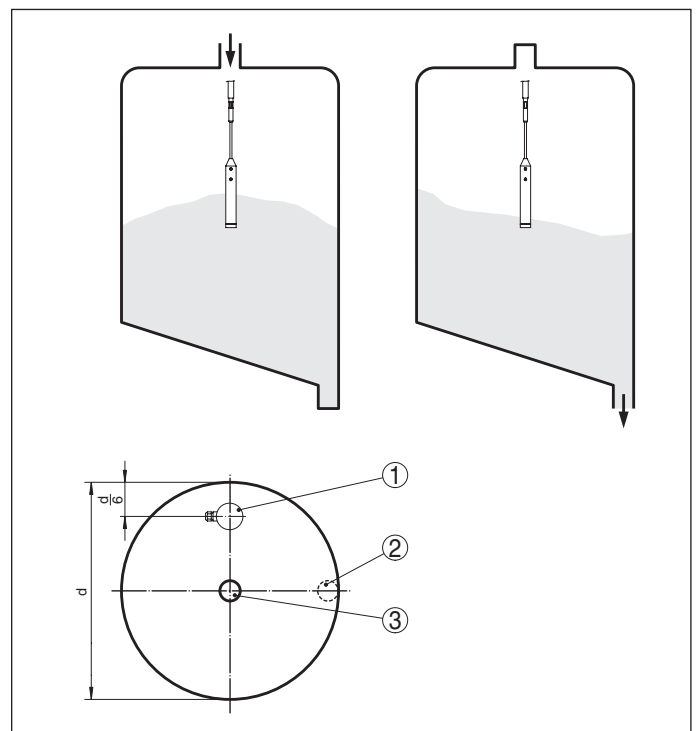

Fig. 15: Filling in the centre, emptying laterally

- 1 VEGACAP
- 2 Discharge opening
- 3 Filling opening

Tensile load

If the cable version is used, make sure the max. tensile load of the suspension cable is not exceeded. Also keep the permissible roof load of your vessel in mind. This should be considered especially when using the instrument for very heavy solids and long meas. lengths. The max. permissible tensile load is stated in chapter "Technical data".

Inflowing medium

If VEGACAP is mounted in the filling stream, unwanted false measurement signals can be generated. For this reason, mount VEGACAP at a position in the vessel where no disturbances, e.g. from filling openings, agitators, etc., can occur.

This applies particularly to instrument versions with a longer probe.

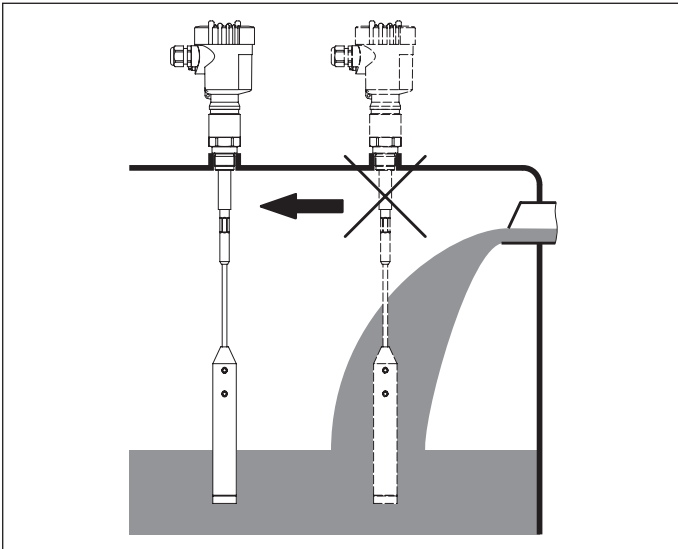

Fig. 16: Inflowing medium

Pressure/Vacuum

The process fitting must be sealed if there is gauge or low pressure in the vessel. Check if the seal material is resistant against the measured product and the process temperature.

Insulating measures in metal vessels such as e.g. covering the thread with teflon tape can interrupt the necessary electrical connection to the vessel. Ground the probe on the vessel.

Length of the level detection probe

Keep in mind when ordering the instrument that when the switching point is reached the probe must be sufficiently immersed according to the desired filling level, and that the depth of immersion depends on the electrical properties (dielectric value) of the medium. An electrode for level detection in oil (dielectric value ~2) requires a considerably deeper immersion than one used in water (dielectric value ~81).

As a rule:

- Non-conductive products > 50 mm
- Conductive products > 30 mm

Lateral load

Make sure that the probe is not subjected to strong lateral forces. Mount the probe at a position in the vessel where no interfering influence, e.g. from agitators, filling opening etc. can occur. This applies particularly to very long rod and cable probes.

Product movement

Mount the probe in such a way that the probe cannot touch the vessel wall and that the screening tube cannot be bent or broken.

Shorten the probe

Partly insulated cable or rod probes can be shortened afterwards. Keep in mind that shortening the probe can change the inherent capacitance of the instrument, which can in turn change the switching point.

The probe is compensated to the respective probe length. Therefore you should state in your order if you intend to shorten the probe.

Tractive forces

If strong tractive forces arise, e.g. during filling or inflowing solids, high tensile loads can be caused. In such cases and for short meas. lengths, use a rod probe as the rod is generally more stable.

If due to the length or mounting location, a cable probe should be necessary, the probe should be strained because the cable can more easily follow the product movements. Make sure that the probe cable is not in contact with the vessel wall.

Metal vessel

Make sure that the mechanical connection of the probe to the vessel is electrically conductive to ensure sufficient grounding.

Use conductive seals such as e.g. copper, lead etc.

Insulating measures such as e.g. covering the thread with teflon tape can interrupt the necessary electrical connection. If this is necessary, use the ground terminal on the housing to connect the instrument with the vessel.

Non-conductive vessels

In non-conductive vessels, e.g. plastic tanks, the second pole of the capacitor must be provided separately, e.g. in the form of the metal supporting structure of the vessel or similar. When using a standard probe, it is necessary to attach a suitable grounding surface. Attach a very broad grounding surface outside on the vessel wall, e.g. wire braiding laminated into the vessel wall or a metal foil glued to the outside of the vessel.

Connect the grounding surface to the ground terminal on the housing.

Conductivity of the product

In special cases, partly insulated probes can be used for level detection in conductive products. The electronics of the probe is short-circuit proof.

Influencing factors

In practice, the dielectric value is subject to certain fluctuations. The following factors can influence of the capacitive measuring principle:

- Bulk density
- Concentration (mixing ratio of the product)
- Temperature
- Conductivity

The more constant the above mentioned factors, the better the conditions for capacitive measurement. Changes in the conditions are generally not critical in products with high dielectric value.

If a very precise switching point is required, or if the the product changes or has a low dielectric value, we recommend lateral mounting - a horizontally mounted rod gets covered quickly over its entire length and has a much more reliable switching function.

You can either mount a standard measuring probe laterally or use an angled measuring probe.

Operating temperatures

If the housing is subject to high ambient temperatures, you have to either use a temperature adapter or disconnect the electronics from the probe and install it in a separate housing at a cooler place (from a process temperature of 200 °C).

With process temperatures up to 300 °C you can use a high temperature probe. With temperatures up to 400 °C, the electronics must be additionally located in a separate housing.

Make sure that the probe is not covered by an existing vessel insulation.

The temperature ranges of the probes are listed in chapter "Technical data".

Concrete vessel

To ensure sufficient grounding in concrete vessels, you should connect the ground terminal of the measuring probe to the steel reinforcement of the vessel.

Dielectric constant

In products with low dielectric value and slight level changes you should try to increase the capacitance change. If the dielectric value is less than 1.5, special measures are necessary to ensure that the level is detected reliably. E.g. additional surfaces can be attached or a screening tube used with high sockets, etc.

For applications with high sockets and products with low dielectric value you can compensate the strong influence of the metal socket with a concentric tube.

Electrically conductive products react like products with very high dielectric value.

A detailed list with dielectric values is available on our homepage under "Services - Downloads- Lists of measured products".

Corrosive, abrasive products

Various isolating materials are available for very corrosive or abrasive products. If metal is not chemically resistant to the medium, use a plated flange.

Condensation

If condensation forms on the vessel top, the resulting liquid draining off can cause measurement errors (bridging) particularly with partly insulated probes.

For that reason, use a screening tube. The screening tube is permanently attached to the probe and must be specified in the order. The length of the screening tube depends on the amount of condensate and its flow behaviour.

Protective cover

To protect the sensor against pollution and strong heat due to the sun, you can snap a weather protective cover onto the sensor housing.

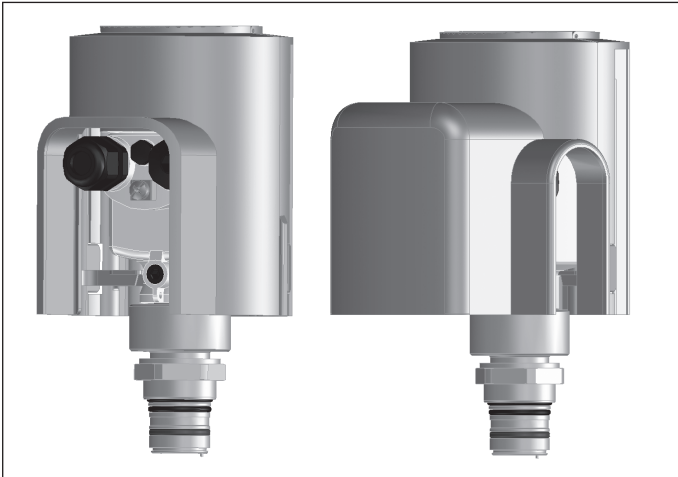

Fig. 17: Weather protection cover in different versions

5 Electrical connection

5.1 Preparing the connection

Note safety instructions

Always keep in mind the following safety instructions:

- Connect only in the complete absence of line voltage

Take note of safety instructions for Ex applications

In hazardous areas you must take note of the respective regulations, conformity and type approval certificates of the sensors and power supply units.

Select power supply

Connect the operating voltage according to the following diagrams. Oscillators with relay output and contactless electronic switch are designed in protection class 1. To maintain this protection class, it is absolutely necessary that the ground conductor be connected to the internal ground terminal. Take note of the general installation regulations. As a rule, connect VEGACAP to vessel ground (PA), or in case of plastic vessels, to the next ground potential. On the side of the housing there is a ground terminal between the cable entries. This connection serves to drain off electrostatic charges. In Ex applications, the installation regulations for hazardous areas must be given priority.

The data for power supply are specified in chapter "Technical data".

Select connection cable

VEGACAP is connected with standard cable with round cross section. An outer cable diameter of 5 ... 9 mm (0.2 ... 0.35 in) ensures the seal effect of the cable gland.

If cable with a different diameter or wire cross section is used, exchange the seal or use an appropriate cable connection.



In hazardous areas, use only approved cable connections for VEGACAP.

Select connection cable for Ex applications

Take note of the corresponding installation regulations for Ex applications.

5.2 Wiring plan

Relay output

We recommend connecting VEGACAP in such a way that the switching circuit is open when there is a level signal, line break or failure (safe state).

The relays are always shown in non-operative condition.

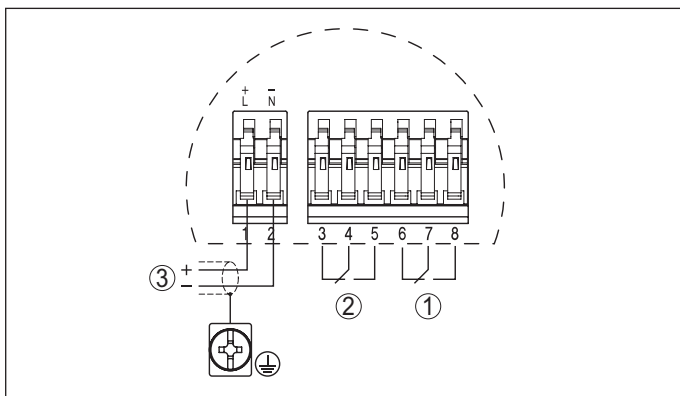

Fig. 18: Wiring plan, single chamber housing

- 1 Relay output
- 2 Relay output
- 3 Voltage supply

Transistor output

We recommend connecting VEGACAP in such a way that the switching circuit is open when there is a level signal, line break or failure (safe state).

state).

The instrument is used to control relays, contactors, magnet valves, warning lights, horns as well as PLC inputs.

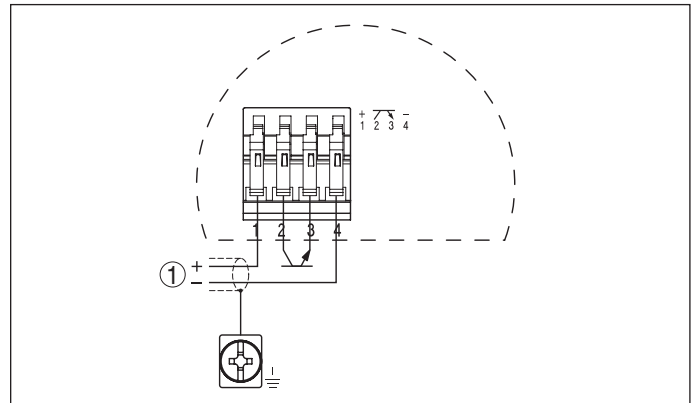

Fig. 19: Wiring plan, single chamber housing

- 1 Voltage supply

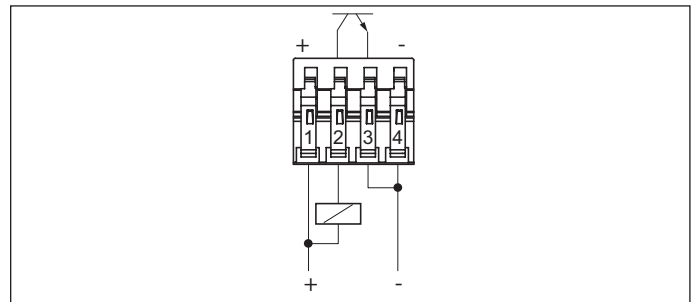

Fig. 20: NPN action

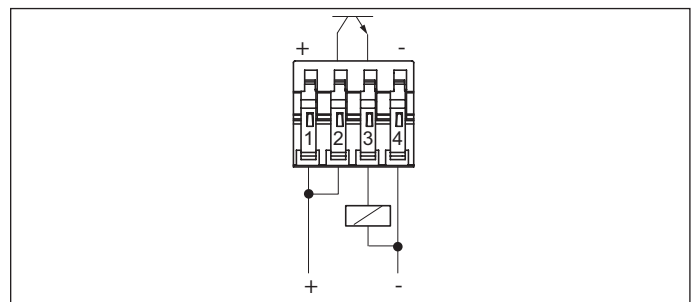

Fig. 21: PNP action

Contactless electronic switch

We recommend connecting VEGACAP in such a way that the switching circuit is open when there is a level signal, line break or failure (safe state).

The contactless electronic switch is always shown in non-operative condition.

The instrument is used for direct control of relays, contactors, magnet valves, warning lights, horns etc. It must not be operated without an intermediately connected load, because the electronics would be destroyed if connected directly to the mains. It is not suitable for connection to low voltage PLC inputs.

Domestic current is temporarily lowered below 1 mA after switching off the load so that contactors, whose holding current is lower than the constant domestic current of the electronics, are reliably switched off.

When VEGACAP is used as part of an overfill protection system according to WHG, also note the regulations of the general type approval.

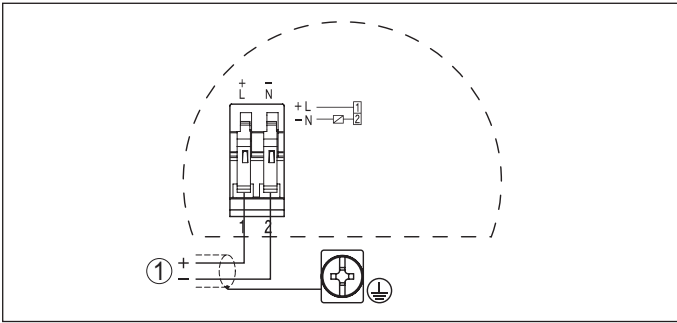

Fig. 22: Wiring plan, single chamber housing

1 Voltage supply

Two-wire output

We recommend connecting VEGACAP in such a way that the switching circuit is open when there is a level signal, line break or failure (safe state).

For connection to a VEGATOR signal conditioning instrument dto. Ex. The sensor is powered by the connected VEGATOR signal conditioning instrument. Further information is available in chapter "Technical data", "Ex-technical data" are available in the supplied "Safety information manual".

The wiring example is applicable for all suitable signal conditioning instruments.

Take note of the operating instructions manual of the signal conditioning instrument. Suitable signal conditioning instruments are listed in chapter "Technical data".

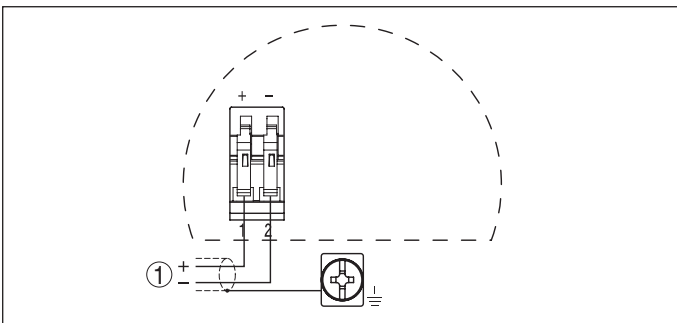

Fig. 23: Wiring plan, single chamber housing

1 Voltage supply

6 Adjustment

6.1 Adjustment, general

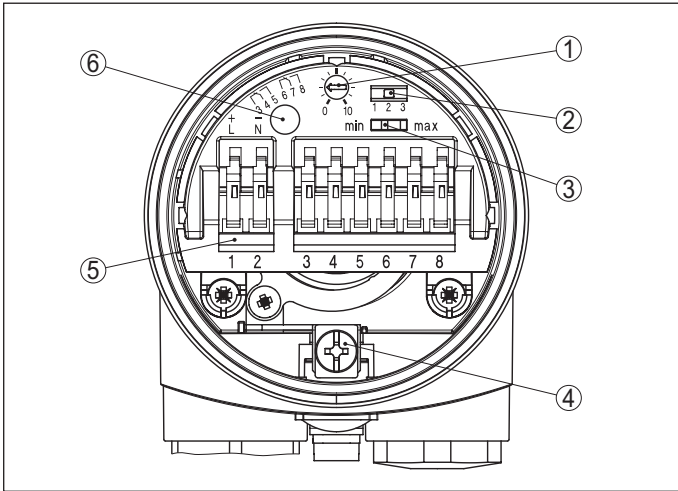

Fig. 24: Adjustment elements electronics module, e.g. relay output (CP60R)

- 1 Potentiometer for switching point adaptation (not with two-wire electronics)
- 2 Range switch
- 3 DIL switch for mode adjustment (not with two-wire electronics)
- 4 Ground terminal
- 5 Connection terminals
- 6 Control lamp

Switching point adaptation (1)

By using the potentiometer you can adapt the switching point of VEGACAP to the medium.

With two-wire electronics the switching point is adjusted on the signal conditioning instrument. For that reason there is no potentiometer.

Range switch (2)

Select the capacitance range of the probe with the mode switch.

With the potentiometer (1) and the mode switch (2) you can change the switching point of the probe or adapt the sensitivity of the probe to the electrical properties of the product and the conditions in the vessel.

This is necessary that the point level switch can for example also detect products with very low or very high dielectric constant reliably.

Capacitance range

- Range 1: 0 ... 20 pF (sensitive)
- Range 2: 0 ... 85 pF
- Range 3: 0 ... 450 pF (insensitive)

Examples of dielectric values: air = 1, oil = 2, acetone = 20, water = 81 etc.

Turn the potentiometer (1) anticlockwise to make the probe more sensitive.

Mode adjustment (3)

With the mode adjustment (min./max.) you can change the switching condition of the output. You can set the required mode (max. - max. detection or overflow protection, min. - min. detection or dry run protection).

With two-wire electronics the mode is selected on the signal conditioning instrument. For that reason there is no mode switch.

LED display (6)

Diode for indication of the switching status (with plastic housing visible from outside).

7 Dimensions

Housing

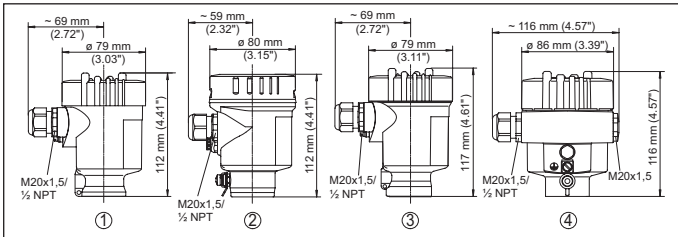

Fig. 25: Housing versions

- 1 Plastic housing
- 2 Stainless steel housing
- 3 Stainless steel housing - precision casting
- 3 Aluminium housing

VEGACAP 62

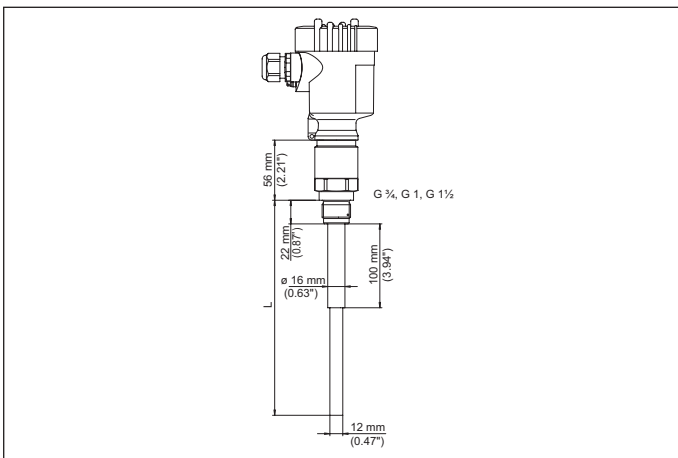

Fig. 26: VEGACAP 62 - threaded version

L Sensor length, see chapter "Technical data"

VEGACAP 65

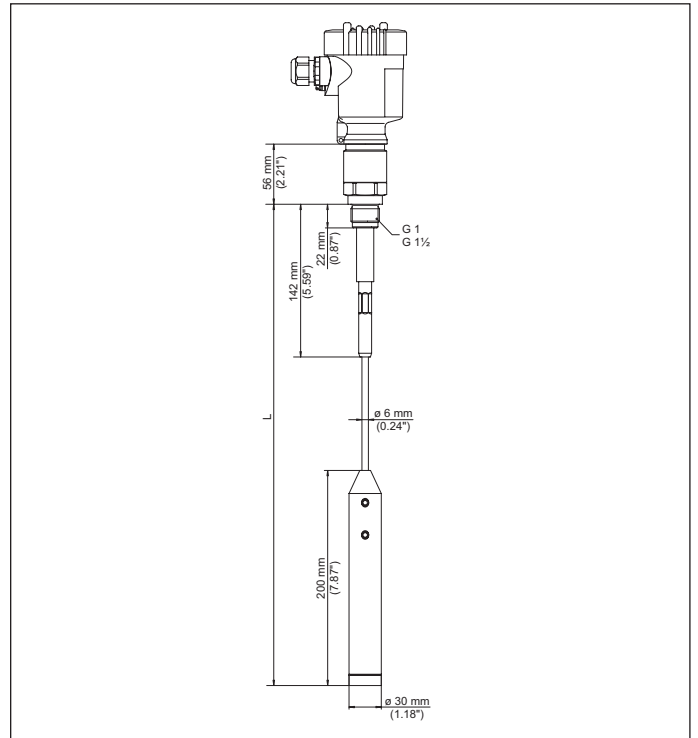

Fig. 27: VEGACAP 65 - threaded version

L Sensor length, see chapter "Technical data"

VEGACAP 66

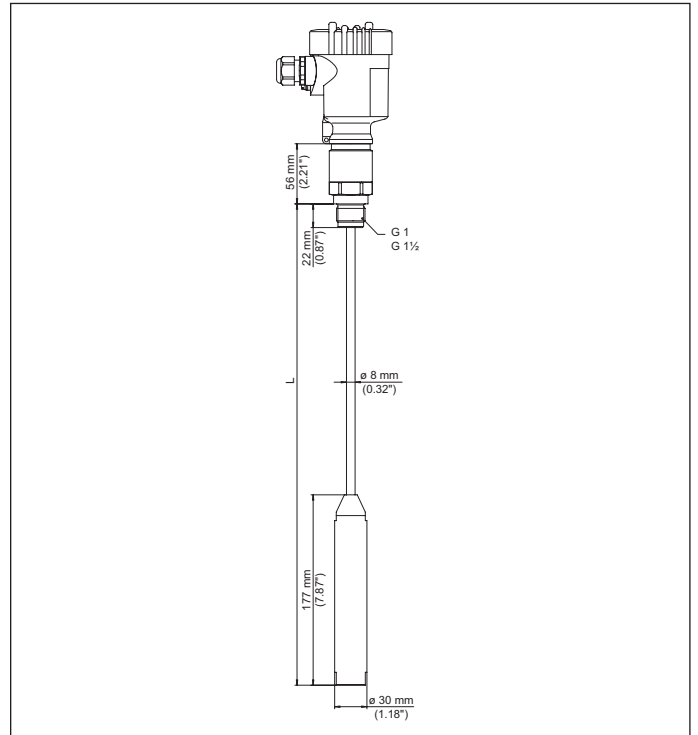

Fig. 28: VEGACAP 66 - threaded version

L Sensor length, see chapter "Technical data"

VEGACAP 67

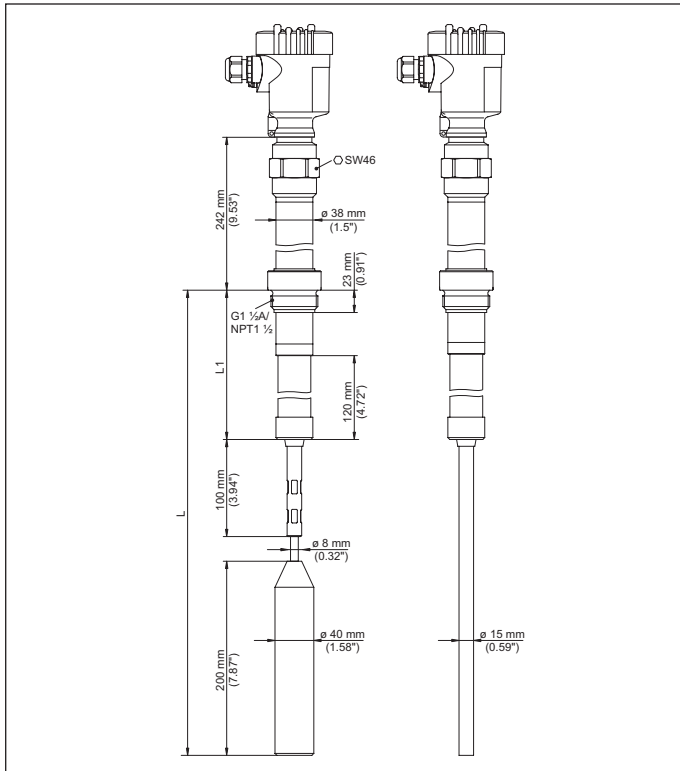

Fig. 29: VEGACAP 67 - threaded version G1½ and 1½ NPT, -50 ... +300 °C (-58 ... +572 °F)

Version -50 ... +400 °C (-58 ... +752 °F) only with external housing.
See supplementary instructions manual "External housing - VEGACAP, VEGACAL"

- L Sensor length, see chapter "Technical data"
- L1 Supporting tube length, see chapter "Technical data"



All statements concerning scope of delivery, application, practical use and operating conditions of the sensors and processing systems correspond to the information available at the time of printing.
Subject to change without prior notice

© VEGA Grieshaber KG, Schiltach/Germany 2016

VEGA Grieshaber KG
Am Hohenstein 113
77761 Schiltach
Germany

Phone +49 7836 50-0
Fax +49 7836 50-201
E-mail: info.de@vega.com
www.vega.com

VEGA

29982-EN-160930