

Datasheet L13I+C2I

Mass Flow Meters for Liquids

> Introduction

Bronkhorst® model L13I+C2I Liquid Flow Meters (LFMs) are suited for precise measurement of low flow ranges. The LFM consists of a thermal mass flow sensor and a microprocessor based pc-board with signal and fieldbus conversion and a PID controller for optional mass flow control by means of a separately mounted control valve. The mass flow, expressed in grams per hour, is provided as analog signal or digitally via RS232 or optional fieldbus. The liquid flow meters are scaled and calibrated according to customer's requirements.



LIQUI-FLOW™ Mass Flow Meter model L13I+C2I

> Technical specifications

Measurement / control system

Accuracy (incl. linearity) (Based on actual calibration)	: ± 1% FS
Turndown	: 1 : 20 (5...100%)
Repeatability	: ±0,2% FS typical H ₂ O
Operating temperature	: 5...50°C
Temperature sensitivity	: ± 0,1% FS/°C
Attitude sensitivity	: negligible
Warm-up time	: 30 min. for optimum accuracy 10 min. for accuracy ± 2% FS
Temperature range	: 5...50°C

Mechanical parts

Material (wetted parts)	: stainless steel 316L/320; others on request
Process connections	: 1/8", 1/4" or 6 mm OD compression
Seals	: Kalrez®-6375; others on request
Ingress protection (housing)	: IP40
Pressure rating	: 100 bar abs

Although all specifications in this datasheet are believed to be accurate, the right is reserved to make changes without notice or obligation.

Electrical properties

Power supply	: +15...24 Vdc ±10%
Power consumption	: max. 100 mA; add 50 mA for PROFIBUS, if applicable
Analog output (0...100%)	: 0...5 (10) Vdc, min. load impedance > 2 kΩ; 0 (4)...20 mA (sourcing), max. load impedance < 375 Ω
Analog setpoint (0...100%) (for LFM + control valve)	: 0...5 (10) Vdc, min. load impedance > 100 kΩ; 0 (4)...20 mA, load impedance ~250 Ω
Digital communication	: standard RS232; options: PROFIBUS-DP®, DeviceNet™, Modbus-RTU, EtherCAT®, FLOW-BUS

> Ranges (based on water)

Model	min.flow	max.flow
L13I+C2I	0,25...5 g/h	5...100 g/h

Intermediate ranges are available

> Model number identification

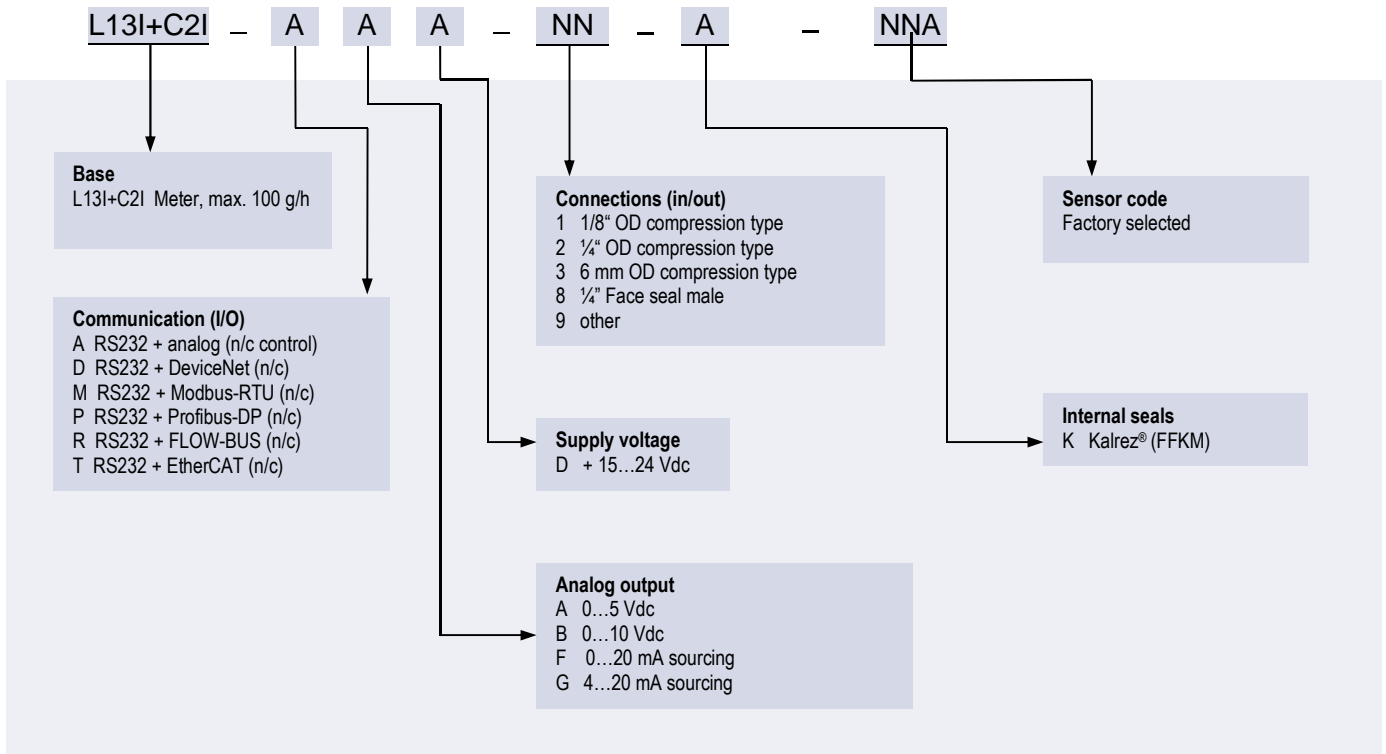

> Thermal mass flow measuring principle

A LIQUI-FLOW™ thermal Mass Flow Meter for liquids is basically a stainless steel tube without any moving parts or built-in obstructions. The heater/sensor assembly is arranged around the tube and, by following the anemometric principle, a constant difference in temperature (ΔT) is created and the energy (P) required to maintain the ΔT is dependent of the mass flow rate. Due to the benefits of the unique patented sensor, the fluid will be warmed to a maximum of 5°C, thereby making the LIQUI-FLOW™ series suitable for fluids with low boiling points.

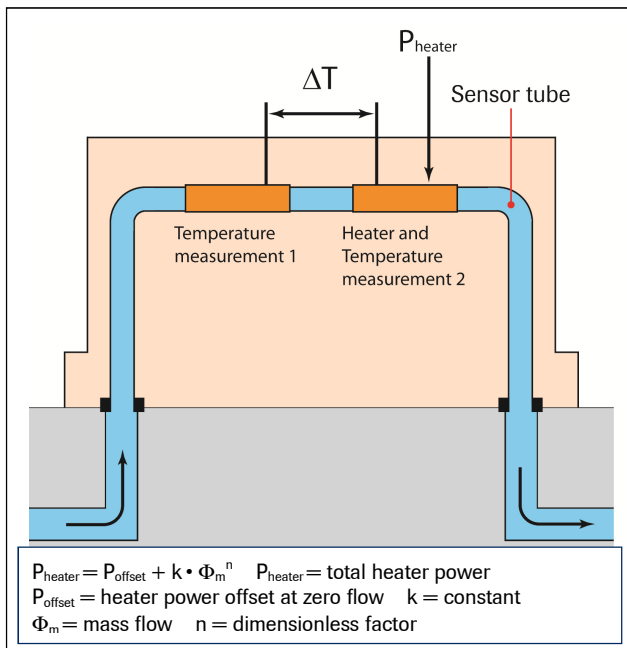

Functional scheme of the thermal mass flow sensor

> State of the art digital design

Today's LIQUI-FLOW™ series are equipped with a digital pc-board, offering high accuracy, excellent temperature stability and fast response. The basic digital pc-board contains all of the general functions needed for measurement and control. In addition to the standard RS232 output the instruments also offer analog I/O. Furthermore, an integrated interface board provides DeviceNet™, Profibus-DP®, Modbus-RTU, EtherCAT® or FLOW-BUS protocols.

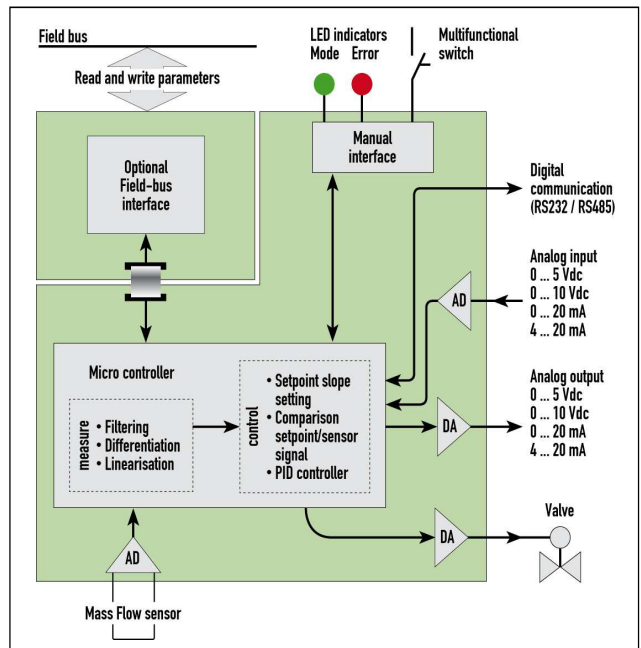

Functional scheme of the digital PC-board

> Hook-up diagram for analog or RS232 communication

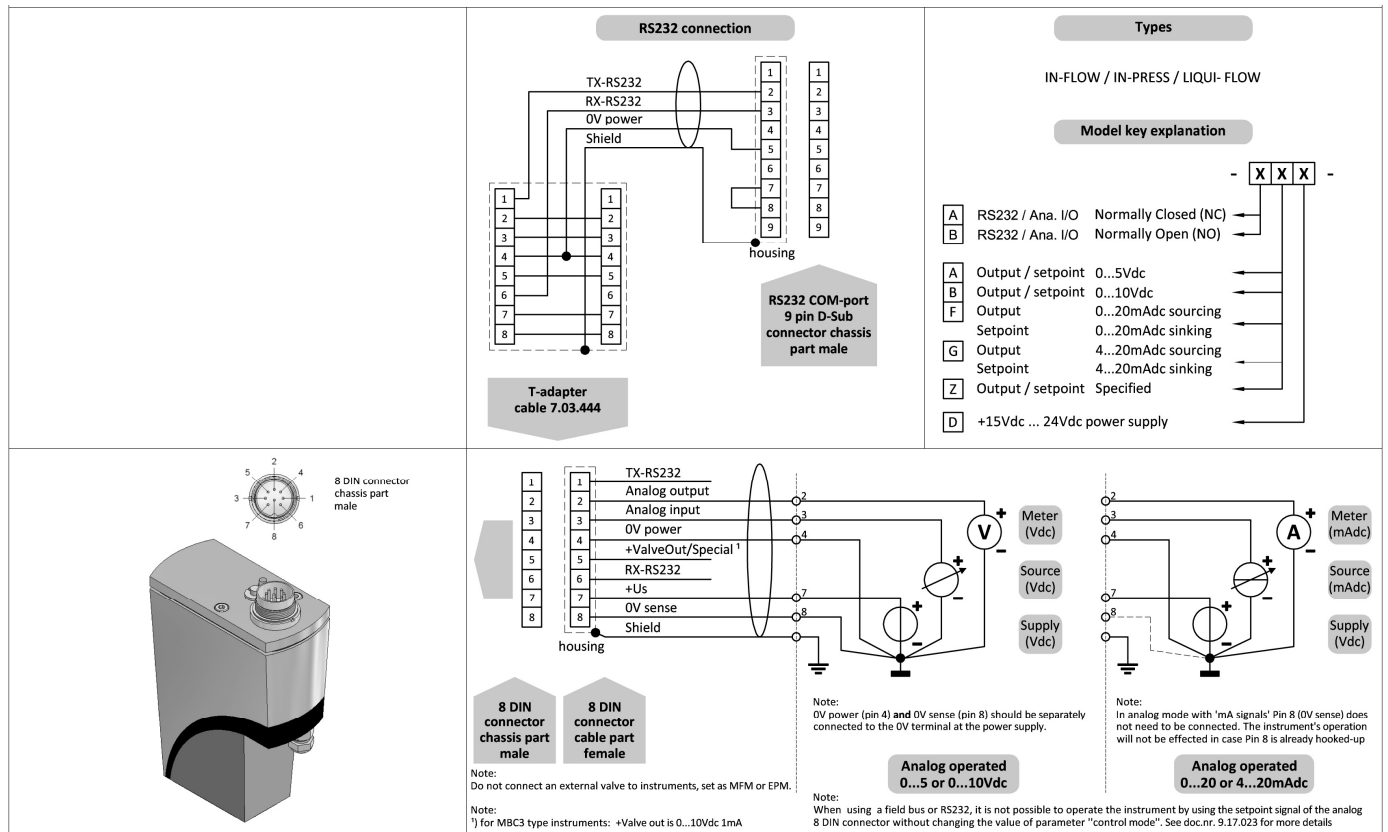

> Hook-up diagrams for fieldbus communication

For the available fieldbus options we refer to the various hook-up diagrams as indicated below. If you are viewing this datasheet in digital format, you may use the hyperlink to each of the drawings. Otherwise please visit the download section on www.bronkhorst.com or contact our local representatives.

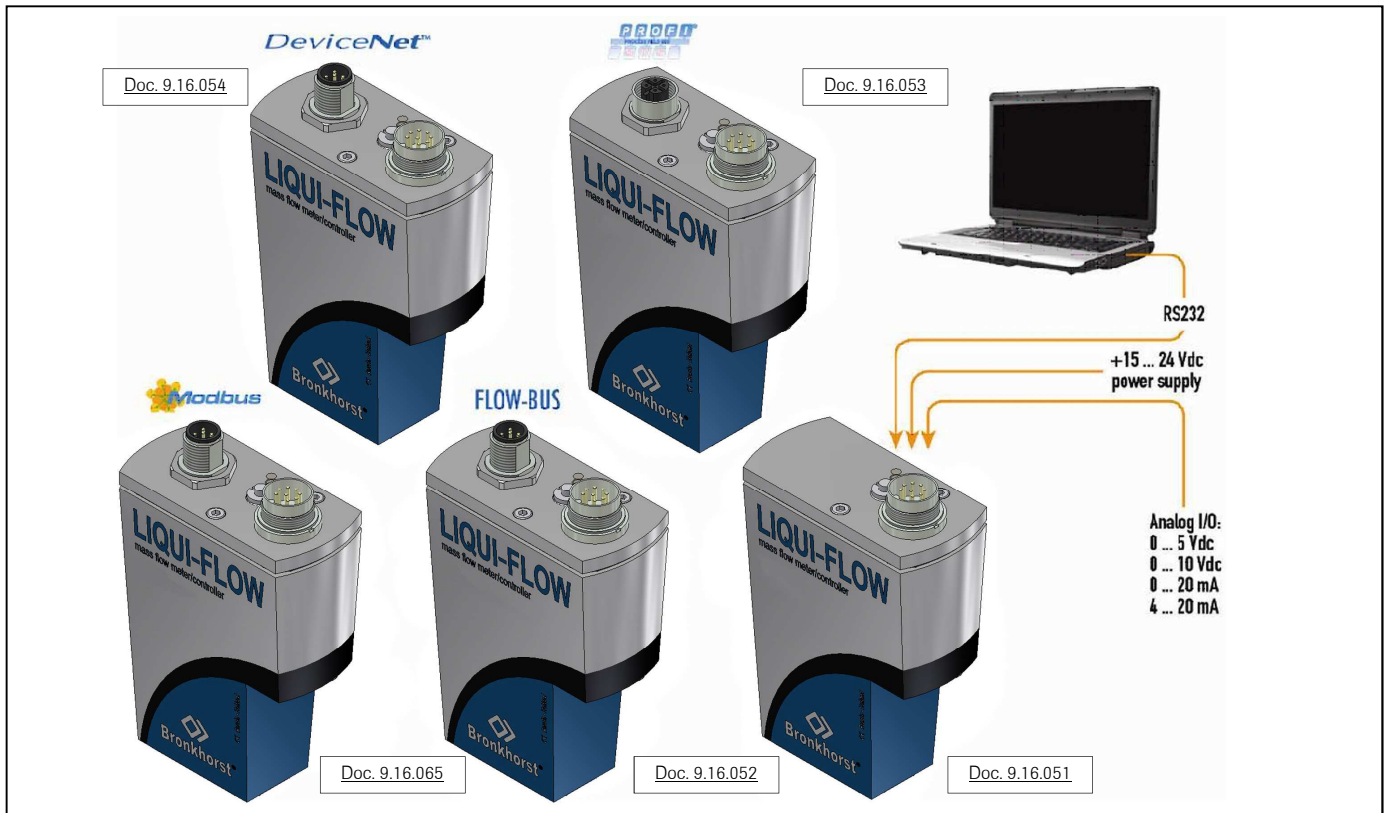

> Dimensions (mm) and weight (kg)

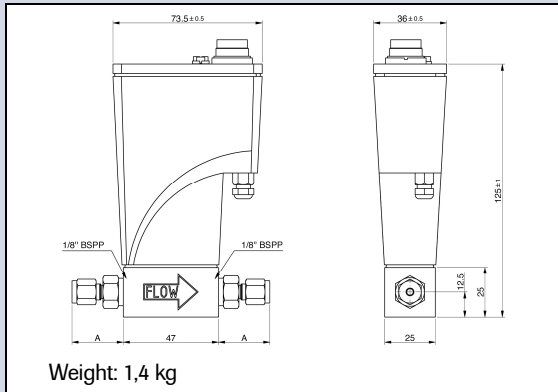



Dimension table adapters (RS-type)



		1/8"BSPP
Compression type		Size A
adapter	3 mm OD	25.3
adapter	6 mm OD	27.6
adapter	8 mm OD	28.6
adapter	1/16" OD	20.6
adapter	1/8" OD	25.3
adapter	1/4" OD	27.6
adapter	3/8" OD	29.5
Face-seal male		A
adapter	1/8" inlet	17.8
adapter	1/4" inlet	23.7

Compression type

> Options and accessories

<ul style="list-style-type: none"> - Free software support for operation, monitoring, optimizing or to interface between digital instruments and windows software. 	
<ul style="list-style-type: none"> - BRIGHT compact local Readout/Control module - E-5700 / E-7000 Power Supply 	
<ul style="list-style-type: none"> - Interconnecting cables for power and analog/digital communication - PiPS Plug-in Power Supply 	

> Alternatives

<ul style="list-style-type: none"> - μ-FLOW series Liquid Flow Meter for ultra low flow rates (100 mg/h...2 g/h FS) 	
<ul style="list-style-type: none"> - LIQUI-FLOW™ model L23 LFM (100...1000 g/h FS) 	
<ul style="list-style-type: none"> - LIQUI-FLOW mini model LM02 microfluidic LFM for ultra low flow rates (75...600 mg/h FS) 	