

Operating Instructions

Rugged controller and display
instrument for level sensors

VEGAMET 862

4 ... 20 mA/HART



Document ID: 58867



VEGA

Contents

1	About this document	4
1.1	Function	4
1.2	Target group	4
1.3	Symbols used.....	4
2	For your safety	5
2.1	Authorised personnel	5
2.2	Appropriate use.....	5
2.3	Warning about incorrect use.....	5
2.4	General safety instructions	5
2.5	Installation and operation in the USA and Canada	6
2.6	Safety instructions for Ex areas	6
3	Product description	7
3.1	Configuration.....	7
3.2	Principle of operation.....	9
3.3	Adjustment	9
3.4	Packaging, transport and storage.....	10
3.5	Accessories.....	11
4	Mounting	12
4.1	General instructions	12
4.2	Mounting instructions	12
5	Connecting to power supply	15
5.1	Preparing the connection	15
5.2	Sensor input mode active/passive.....	16
5.3	Digital input mode active/passive	16
5.4	Connecting.....	16
5.5	Wiring plan	17
5.6	Switch-on phase.....	19
6	Access protection	20
6.1	Bluetooth radio interface	20
6.2	Protection of the parameterization.....	20
6.3	Storing the codes in myVEGA	21
7	Set up with the integrated display and adjustment unit	22
7.1	Adjustment system	22
7.2	Measured value/status and menu item display	23
7.3	Menu overview	24
7.4	Setup steps	25
8	Setup with smartphone/tablet (Bluetooth)	33
8.1	Preparations.....	33
8.2	Connecting.....	33
8.3	Parameter adjustment	34
9	Setup with PC/notebook (Bluetooth)	35
9.1	Preparations.....	35
9.2	Connecting.....	35
9.3	Parameter adjustment	36

10 Measured value memory/data logger	37
11 Applications and functions.....	40
11.1 Level measurement in storage tanks with overflow protection/dry run protection	40
11.2 Pump station with pump control function.....	43
11.3 Screen control.....	51
11.4 Flow measurement flume/weir.....	53
12 Diagnostics and servicing	57
12.1 Maintenance	57
12.2 Rectify faults.....	57
12.3 Diagnosis, fault messages	57
12.4 Software update	60
12.5 How to proceed if a repair is necessary.....	61
13 Dismount.....	62
13.1 Dismounting steps.....	62
13.2 Disposal	62
14 Certificates and approvals	63
14.1 Radio licenses.....	63
14.2 Approvals for Ex areas	63
14.3 Approvals as overflow protection.....	63
14.4 Metrological approvals	63
14.5 EU conformity.....	63
14.6 Environment management system	63
15 Supplement	65
15.1 Technical data	65
15.2 Overview applications/functionality	68
15.3 Dimensions	71
15.4 Industrial property rights.....	74
15.5 Licensing information for open source software	74
15.6 Trademark.....	74

1 About this document

1.1 Function

This instruction provides all the information you need for mounting, connection and setup as well as important instructions for maintenance, fault rectification, the exchange of parts and the safety of the user. Please read this information before putting the instrument into operation and keep this manual accessible in the immediate vicinity of the device.

1.2 Target group

This operating instructions manual is directed to trained personnel. The contents of this manual must be made available to the qualified personnel and implemented.

1.3 Symbols used



Document ID

This symbol on the front page of this instruction refers to the Document ID. By entering the Document ID on www.vega.com you will reach the document download.



Information, note, tip: This symbol indicates helpful additional information and tips for successful work.



Note: This symbol indicates notes to prevent failures, malfunctions, damage to devices or plants.



Caution: Non-observance of the information marked with this symbol may result in personal injury.



Warning: Non-observance of the information marked with this symbol may result in serious or fatal personal injury.



Danger: Non-observance of the information marked with this symbol results in serious or fatal personal injury.



Ex applications

This symbol indicates special instructions for Ex applications.



List

The dot set in front indicates a list with no implied sequence.



Sequence of actions

Numbers set in front indicate successive steps in a procedure.



Battery disposal

This symbol indicates special information about the disposal of batteries and accumulators.

2 For your safety

2.1 Authorised personnel

All operations described in this documentation must be carried out only by trained, qualified personnel authorised by the plant operator.

During work on and with the device, the required personal protective equipment must always be worn.

2.2 Appropriate use

VEGAMET 862 is a universal controller for connection of two 4 ... 20 mA/HART sensors.

You can find detailed information about the area of application in chapter " *Product description*".

Operational reliability is ensured only if the instrument is properly used according to the specifications in the operating instructions manual as well as possible supplementary instructions.

2.3 Warning about incorrect use

Inappropriate or incorrect use of this product can give rise to application-specific hazards, e.g. vessel overflow through incorrect mounting or adjustment. Damage to property and persons or environmental contamination can result. Also, the protective characteristics of the instrument can be impaired.

2.4 General safety instructions

This is a state-of-the-art instrument complying with all prevailing regulations and directives. The instrument must only be operated in a technically flawless and reliable condition. The operator is responsible for the trouble-free operation of the instrument. When measuring aggressive or corrosive media that can cause a dangerous situation if the instrument malfunctions, the operator has to implement suitable measures to make sure the instrument is functioning properly.

During the entire duration of use, the user is obliged to determine the compliance of the necessary occupational safety measures with the current valid rules and regulations and also take note of new regulations.

The safety instructions in this operating instructions manual, the national installation standards as well as the valid safety regulations and accident prevention rules must be observed by the user.

For safety and warranty reasons, any invasive work on the device beyond that described in the operating instructions manual may be carried out only by personnel authorised by the manufacturer. Arbitrary conversions or modifications are explicitly forbidden. For safety reasons, only the accessory specified by the manufacturer must be used.

To avoid any danger, the safety approval markings and safety tips on the device must also be observed.

2.5 Installation and operation in the USA and Canada

This information is only valid for USA and Canada. Hence the following text is only available in the English language.

Installations in the US shall comply with the relevant requirements of the National Electrical Code (ANSI/NFPA 70).

Installations in Canada shall comply with the relevant requirements of the Canadian Electrical Code.

2.6 Safety instructions for Ex areas

For applications in explosion-proof areas (Ex), only devices with corresponding Ex approval may be used. Observe the Ex-specific safety instructions. These are an integral part of the operating instructions and are enclosed with every device with Ex approval.

3 Product description

3.1 Configuration

Scope of delivery

The scope of delivery encompasses:

- Controller VEGAMET 862
- Mounting plate
- Screws/plugs for mounting
- Cable glands/Blind plugs (optional)
- Ground terminal for cable screening

- Information sheet "*Documents and software*" with:
 - Instrument serial number
 - QR code with link for direct scanning

- Information sheet "*PINs and Codes*" with:
 - Bluetooth access code

- Information sheet "*Access protection*" with:
 - Bluetooth access code
 - Emergency Bluetooth unlock code
 - Emergency device code

The further scope of delivery encompasses:

- Documentation
 - Ex-specific "*Safety instructions*" (with Ex versions)
 - Radio licenses
 - If necessary, further certificates



Note:

Optional instrument features are also described in this operating instructions manual. The respective scope of delivery results from the order specification.

Scope of this operating instructions

This operating instructions manual applies to the following instrument versions:

- Hardware version from 1.0.0
- Software version from 1.10.0

Constituent parts

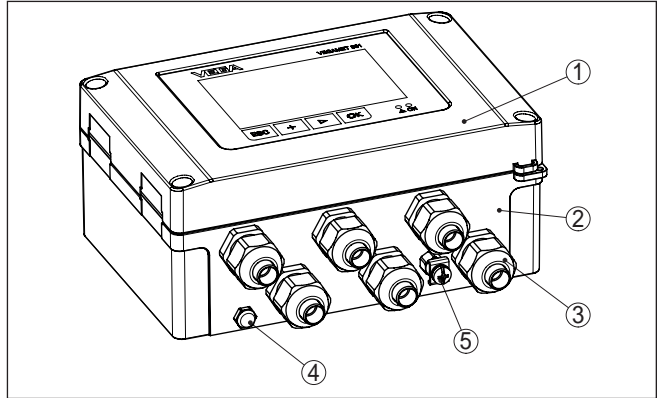

Fig. 1: VEGAMET 862

- 1 Display and adjustment unit
- 2 Housing with cable glands and connection compartment
- 3 Mounting plate
- 4 Ventilation/pressure compensation
- 5 Ground terminal for cable screening

Type label

The type label contains the most important data for identification and use of the instrument:

- Instrument type
- Information about approvals
- Technical data
- Serial number of the instrument
- QR code for device documentation
- Number code for Bluetooth access
- Manufacturer information

Documents and software

Move to "www.vega.com" and enter in the search field the serial number of your instrument.

There you can find the following information about the instrument:

- Order data
- Documentation
- Software

Alternatively, you can find all via your smartphone:

- Scan the QR-code on the type label of the device or
- Enter serial number manually in the VEGA Tools app (available free of charge in the respective stores)



Information:

If the serial number or the QR code on the type label cannot be read, they can be found additionally on the display cover inside the device.

Application area	<h3>3.2 Principle of operation</h3> <p>The VEGAMET 862 controller feeds the connected 4 ... 20 mA or HART sensors, processes the measured values and displays them. A large display for data visualisation is integrated in the housing designed for rough field conditions.</p> <p>It enables simple implementation of pump controls, flow measurements on open channels and weirs, totalizers, data loggers, difference, sum and average value calculations. With VEGAMET 862, limit values can be reliably monitored and relays can be switched, e.g. for an overflow protection according to WHG.</p> <p>Due to its various possibilities it is suitable for many industrial branches.</p>
Functional principle	<p>The VEGAMET 862 controller can power the connected sensors and process their measurement signals. The requested parameter is shown on the display and also output to the integrated current output for further processing. The measurement signal can thus be transferred to a remote display or a superordinate control system. Operating relays for control of pumps or other devices are also integrated.</p>
Local adjustment	<h3>3.3 Adjustment</h3> <p>On-site adjustment of the device is carried out via the integrated display and adjustment unit.</p>
Wireless adjustment	<p>The optionally integrated Bluetooth module enables in addition a wireless adjustment of VEGAMET 862 via standard adjustment tool:</p> <ul style="list-style-type: none">● Smartphone/tablet (iOS or Android operating system)● PC/notebook with Bluetooth LE or Bluetooth USB adapter (Windows operating system)



Information:

Certain setting options are not possible or only possible to a limited extent with the integrated display and adjustment unit, for example the settings for flow measurement or pump control. For these applications, the use of PACTware/DTM or the VEGA Tools app is recommended. An overview of the available applications and functions as well as their adjustment options can be found in the appendix.

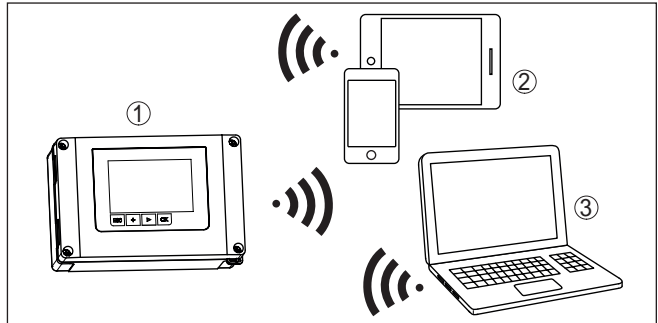

Fig. 2: Wireless connection to standard adjustment tools with integrated Bluetooth LE or alternatively Bluetooth USB adapter.

- 1 VEGAMET 862
- 2 Smartphone/Tablet
- 3 PC/Notebook

3.4 Packaging, transport and storage

Packaging

Your instrument was protected by packaging during transport. Its capacity to handle normal loads during transport is assured by a test based on ISO 4180.

The packaging consists of environment-friendly, recyclable cardboard. For special versions, PE foam or PE foil is also used. Dispose of the packaging material via specialised recycling companies.

Transport

Transport must be carried out in due consideration of the notes on the transport packaging. Nonobservance of these instructions can cause damage to the device.

Transport inspection

The delivery must be checked for completeness and possible transit damage immediately at receipt. Ascertained transit damage or concealed defects must be appropriately dealt with.

Storage

Up to the time of installation, the packages must be left closed and stored according to the orientation and storage markings on the outside.

Unless otherwise indicated, the packages must be stored only under the following conditions:

- Not in the open
- Dry and dust free
- Not exposed to corrosive media
- Protected against solar radiation
- Avoiding mechanical shock and vibration
- Storage and transport temperature see chapter " *Supplement - Technical data - Ambient conditions*"
- Relative humidity 20 ... 85 %

Storage and transport temperature

3.5 Accessories

Sun shade

The sun protection protects the device from direct sunlight and thus prevents overheating of the electronics. It also improves the readability of the display when exposed to sunlight. The sun protection can be used for wall and pipe mounting.

Pipe mounting set

The pipe mounting set is used for optimal and safe mounting of the devices in horizontal and vertical mounting on pipes.

4 Mounting

4.1 General instructions

Mounting options

The field housing of the VEGAMET 862 is equally suitable for outdoor or indoor installation due to its degree of protection IP66/IP67 and Type 4X. The standard version is designed for wall mounting. A mounting adapter for pipe mounting is available as an option.

Ambient conditions

The instrument is suitable for standard and extended ambient conditions acc. to DIN/EN/IEC/ANSI/ISA/UL/CSA 61010-1. It can be used indoors as well as outdoors.

Avoid direct sunlight or use the optionally available sun shade.

Make sure that the environmental and ambient conditions specified in chapter " *Technical data* " are maintained.

Protection against moisture

Protect your instrument against moisture ingress through the following measures:

- Use the recommended connection cable (see chapter " *Connecting to power supply* ")
- Tighten the cable gland
- Mount the instrument in such a way that the cable glands point downward
- Loop the connection cable downward in front of the cable gland

This applies mainly to outdoor installations, in areas where high humidity is expected (e.g. through cleaning processes) and on cooled or heated vessels.

The visible area of the front panel must be protected from knocks, otherwise water can penetrate through breaking of the front foil. In this case, protection against accidental contact can no longer be ensured.



Caution:

Make sure that during installation or maintenance no moisture or dirt can get inside the instrument.

To maintain the housing protection, make sure that the housing lid is closed during operation and locked, if necessary.

Pressure compensation

The pressure compensation for the housing is realized via a breather element.



Note:

Make sure that the pressure equalization element is always free of buildup during operation. A high-pressure cleaner may not be used for cleaning.

4.2 Mounting instructions

Wall mounting

Fix the mounting plate to the wall using the screws and dowels supplied as shown in the figure below. Make sure that the arrows on the mounting plate point upwards.

Loosen the four screws in the housing cover and open it to the left. Fasten the device to the mounting plate using the screws (M5) supplied.

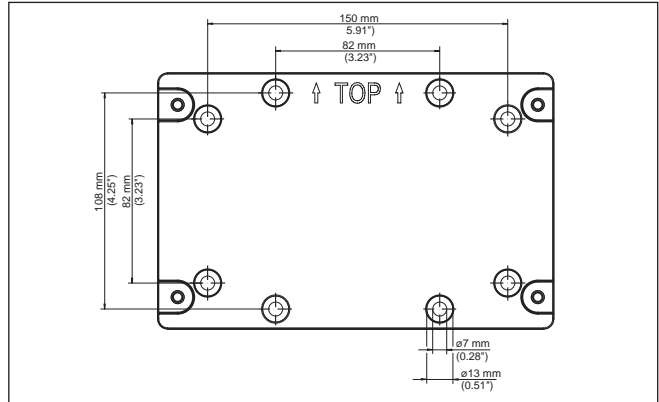

Fig. 3: Mounting plate for wall mounting VEGAMET 862

Tube mounting

The optionally available mounting accessories are required for tube mounting. The kit consists of two pairs of mounting brackets and four mounting screws M6 x 100.

The mounting brackets are screwed to the mounting plate and the tube as shown in the following illustration.

Loosen the four screws in the housing cover and open it to the left. Fasten the device to the mounting plate using the screws (M5) supplied.

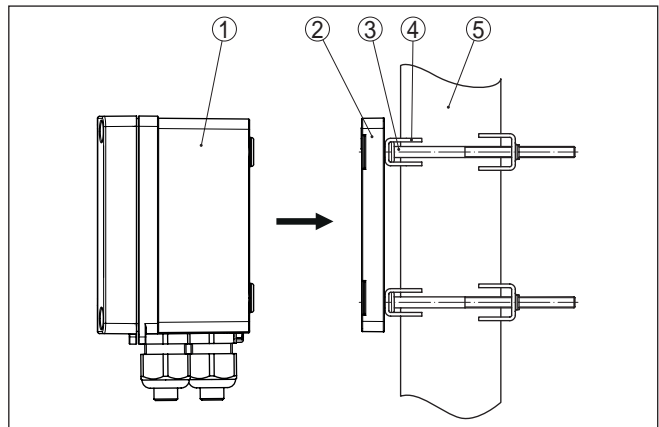

Fig. 4: Tube mounting

- 1 VEGAMET 862
- 2 Mounting plate
- 3 4 screws M6 x 100
- 4 Mounting brackets
- 5 Pipe for diameter 29 ... 60 mm (1.14" to 2.36")

Mounting sun shade

The optional sun protection can be used to protect against direct sunlight. The sunshade is simply mounted between the mounting plate and the controller, this is possible for both wall and pipe mounting.

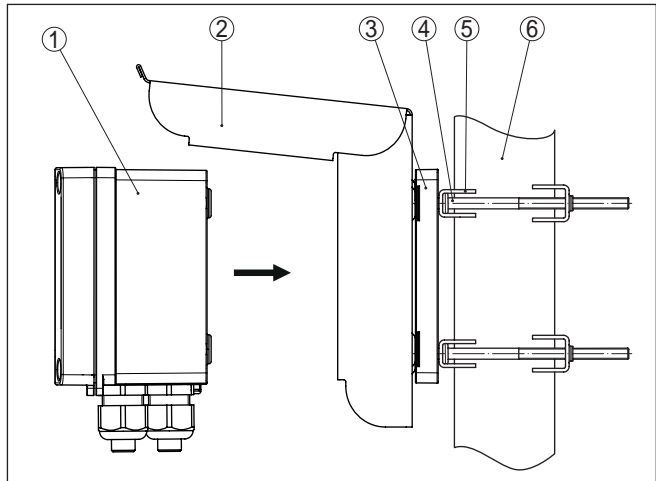

Fig. 5: Mounting sun protection with pipe mounting

- 1 VEGAMET 862
- 2 Sun shade
- 3 Mounting plate
- 4 4 screws M6 x 100
- 5 Mounting brackets
- 6 Pipe for diameter 29 ... 60 mm (1.14" to 2.36")

5 Connecting to power supply

5.1 Preparing the connection

Safety instructions

Always keep in mind the following safety instructions:

- The electrical connection must only be carried out by trained, qualified personnel authorised by the plant operator.
- If overvoltage surges are expected, overvoltage arresters should be installed.



Warning:

Only connect or disconnect in de-energized state.

Voltage supply

The data for power supply are specified in chapter " *Technical data*".

The instrument belongs to protection class I, hence connection of an earth conductor is required.

Connection cable

Use cable with round cross section. The cable diameter must be suitable for the cable gland used to ensure the seal effect of the cable gland (IP protection).

The voltage supply is connected with standard cable according to the national installation standards.

Standard two-wire cable can be used for connecting the sensors. The screening is absolutely necessary to ensure interference-free operation with HART sensors.



Note:

If the temperatures are too high, the cable insulation can be damaged. Hence keep apart from the ambient temperature also the self-heating of the instrument for the temperature resistance of the cable in the connection compartment in mind. ¹⁾

When used in the USA/Canada, only cables with copper conductors may be used.

Cable screening and grounding

When connecting HART sensors, the supplied ground terminal must be attached to the outside of the housing. To do this, carefully remove the pre-embossed opening (\varnothing 6 mm) on the lower side of the device with a suitable tool and screw in the ground terminal.

Connect the cable screening on both ends to ground potential. In the sensor/ VEGAMET 862, the shielding must be connected directly to the internal ground terminal. The ground terminal on the outside of the sensor housing/ VEGAMET 862 must be connected to the potential equalisation (low impedance).

If potential equalisation currents are expected, the screen connection on the side of VEGAMET 862 must be made via a ceramic capacitor (e. g. 1 nF, 1500 V). The low frequency potential equalisation currents are thus suppressed, but the protective effect against high frequency interference signals remains.

¹⁾ With an ambient temperature ≥ 50 °C (122 °F) the connection cable should be suitable for an ambient temperature which is at least 20 °C (36 °F) higher.

Cable glands**Warning:**

In delivery status, all openings are fitted with dust protection caps. These caps are only for protection during transport and are not suitable for protection during operation! Instead, all openings must be closed with cable glands/blind plugs.

Cable glands, NPT adapters or blind plugs that are not included in the scope of delivery must meet the applicable requirements in order to ensure the environmental compatibility of the housing. For outdoor applications, the weather resistance of the accessories to be used must be taken into account. The cable glands, NPT adapters and blind plugs must have a metric thread M20 to be compatible with the threaded openings of the metal plate in the housing.

5.2 Sensor input mode active/passive

Through the selection of the terminals, you can choose between active and passive operation of the sensor input.

- In active mode, the controller provides the power for the connected sensors. Power and measurement data are transmitted over the same two-wire cable. This mode is provided for connection of measuring transducers without separate power supply (sensors in two-wire version).
- In passive mode the sensors are not powered, only the measured value is transmitted. This input is for connection of transmitters with their own separate voltage supply (sensors in four-wire version). The VEGAMET 862 can also be looped into the existing circuit like a normal ammeter.

**Note:**

With a VEGAMET 862 in Ex version, the passive input is not available.

5.3 Digital input mode active/passive

Through the selection of the terminals, you can choose between active and passive operation of the digital input.

- At the active input the controller provides a power supply. This operating mode is intended for the connection of potential-free switching contacts. An external voltage must not be supplied.
- At the passive input a voltage must be supplied via the switching contact. This input is intended for the connection of switching contacts with their own, separate power supply. The permissible voltage specifications for this can be found in the technical data.

With the application " *Pump control*", the digital input can be used for pump monitoring or reset the totalizers.

5.4 Connecting

The voltage supply and inputs and outputs are connected via the spring-loaded terminals.

Connection technology



Information:

Solid cores as well as flexible cores with wire end sleeves are inserted directly into the terminal openings. In case of flexible cores without end sleeves, a small screwdriver must be pressed into the rectangular opening so that the terminal opening is then free. When the screwdriver is pulled out, the terminals are closed again.

You can find further information on the max. wire cross-section in the technical data.

Connecting

Connect the device as described in the following wiring plan.

5.5 Wiring plan

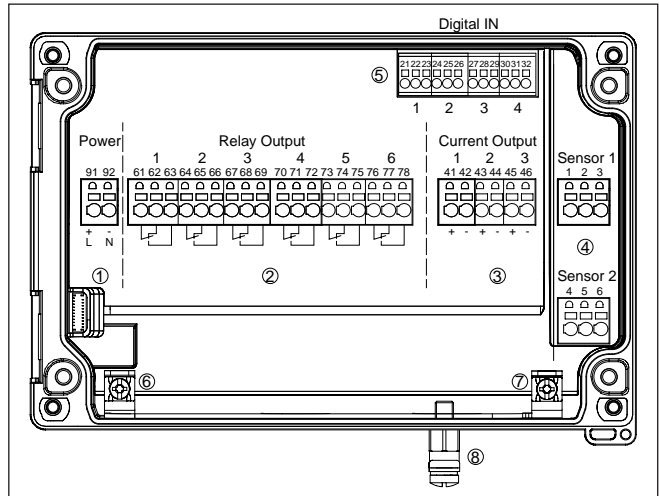

Fig. 6: Wiring plan VEGAMET 862

- 1 Voltage supply of the controller
- 2 Relay outputs 1 ... 6
- 3 Current outputs 1 ... 3
- 4 Sensor inputs 1/2 (active/passive)
- 5 Digital inputs 1 ... 4
- 6 Ground terminal for protective conductor
- 7 Ground terminal for cable screening
- 8 Ground terminal for potential equalization

Detail sensor connection 1

Fig. 7: Sensor input 1 for two-wire/four-wire sensor (active/passive)

- 1 Active input with sensor supply for two-wire sensor
- 2 Passive input without sensor supply for four-wire sensor²⁾
- 3 Two-wire sensor
- 4 Four-wire sensor
- 5 Voltage supply for four-wire sensor
- 6 HART communication sockets for connection of a VEGACONNECT

Detail sensor connection 2

Fig. 8: Sensor input 2 for two-wire/four-wire sensor (active/passive)

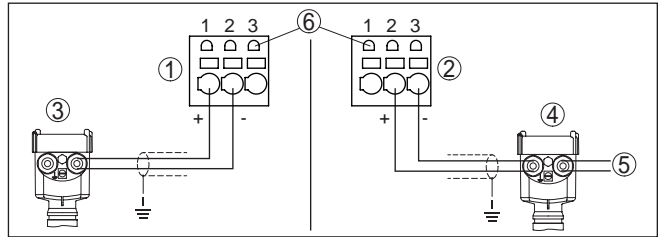
- 1 Active input with sensor supply for two-wire sensor
- 2 Passive input without sensor supply for four-wire sensor³⁾
- 3 Two-wire sensor
- 4 Four-wire sensor
- 5 Voltage supply for four-wire sensor
- 6 HART communication sockets for connection of a VEGACONNECT

²⁾ Passive input not available for Ex version

³⁾ Passive input not available for Ex version

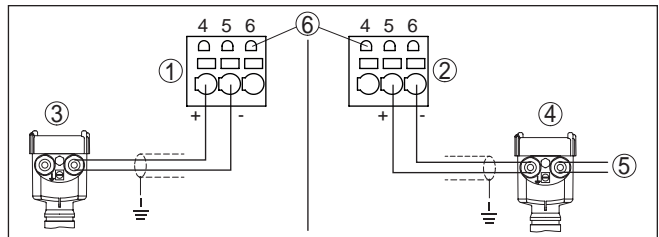
Detail, digital inputs VEGAMET 862

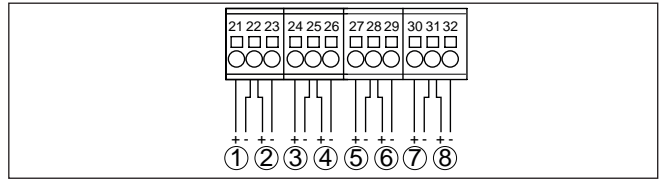

Fig. 9: Connection of the digital inputs

- 1 Digital input 1 (active)
- 2 Digital input 1 (passive)
- 3 Digital input 2 (active)
- 4 Digital input 2 (passive)
- 5 Digital input 3 (active)
- 6 Digital input 3 (passive)
- 7 Digital input 4 (active)
- 8 Digital input 4 (passive)

Connection assignment digital inputs

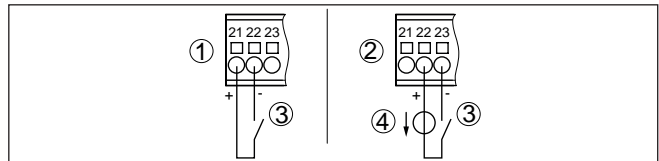

Fig. 10: Connection assignment of the digital inputs (active/passive)

- 1 Active input for floating switching contact
- 2 Passive input for switching contact and external voltage supply
- 3 Switching contact
- 4 External voltage source

5.6 Switch-on phase

After switching on, the device first carries out a short self-check.

- Internal check of the electronics
- Output signals are set to failure, background lighting of the display lights red

The current measured values are then displayed and transmitted to the outputs. The background lighting of the display changes to white.

6 Access protection

6.1 Bluetooth radio interface

Devices with a Bluetooth radio interface are protected against unwanted access from outside. This means that only authorized persons can receive measured and status values and change device settings via this interface.



Information:

If no Bluetooth connection to the device should be possible, Bluetooth communication can be deactivated. Access via app or DTM is thus no longer possible. The Bluetooth function can be deactivated/activated in the menu item " *Extended functions*" under " *Access protection - Bluetooth communication*".

Bluetooth access code

A Bluetooth access code is required to establish Bluetooth communication via the adjustment tool (smartphone/tablet/notebook). This code must be entered once when Bluetooth communication is established for the first time in the adjustment tool. It is then stored in the adjustment tool and does not have to be entered again.

The Bluetooth access code is individual for each device. It is printed on the device housing and is also supplied with the device in the information sheet " *PINs and Codes*". The Bluetooth access code can also be read out via the display and adjustment unit.

The Bluetooth access code can be changed by the user after the first connection is established. If the Bluetooth access code is entered incorrectly, the new entry is only possible after a waiting period has elapsed. The waiting time increases with each further incorrect entry.

Emergency Bluetooth unlock code

The emergency Bluetooth access code enables Bluetooth communication to be established in the event that the Bluetooth access code is no longer known. It can't be changed. The emergency Bluetooth access code can be found in information sheet " *Access protection*". If this document is lost, the emergency Bluetooth access code can be retrieved from your personal contact person after legitimation. The storage and transmission of Bluetooth access codes is always encrypted (SHA 256 algorithm).

6.2 Protection of the parameterization

The settings (parameters) of the device can be protected against unwanted changes. The parameter protection is deactivated on delivery, all settings can be made.

Device code

To protect the parameterization, the device can be locked by the user with the aid of a freely selectable device code. The settings (parameters) can then only be read out, but not changed. The device code is also stored in the adjustment tool. However, unlike the Bluetooth access code, it must be re-entered for each unlock. When using the adjustment app or DTM, the stored device code is then suggested to the user for unlocking.

Emergency device code The emergency device code allows unlocking the device in case the device code is no longer known. It can't be changed. The emergency device code can also be found on the supplied information sheet "*Access protection*". If this document is lost, the emergency device code can be retrieved from your personal contact person after legitimation. The storage and transmission of the device codes is always encrypted (SHA 256 algorithm).

6.3 Storing the codes in myVEGA

If the user has a "*myVEGA*" account, then the Bluetooth access code as well as the device code are additionally stored in his account under "*PINs and Codes*". This greatly simplifies the use of additional adjustment tools, as all Bluetooth access and device codes are automatically synchronized when connected to the "*myVEGA*" account

7 Set up with the integrated display and adjustment unit

7.1 Adjustment system

Function

The integrated display and adjustment unit is used for measured value display, adjustment and diagnosis of the VEGAMET 862. Display and adjustment are carried out via four keys and a graphic-capable display with background lighting.

Certain setting options are not possible or only possible to a limited extent with the integrated display and adjustment unit, for example the settings for flow measurement or pump control. For these applications, the use of PACTware/DTM or the VEGA Tools app is recommended. A tabular overview of the corresponding applications and functions can be found in the appendix.

Display and adjustment elements

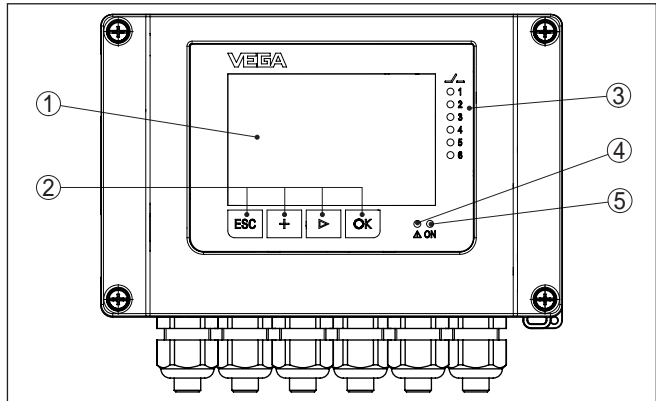

Fig. 11: Display and adjustment elements

- 1 LC display
- 2 Adjustment keys
- 3 Status indication relay
- 4 Status indication fault signal
- 5 Status indication operation

HART communication sockets

Via the HART communication sockets integrated in the terminals, a parameter adjustment of the connected HART sensors can be carried out without interrupting the measuring circuit. The resistor required for this purpose (230 Ω) is already integrated in VEGAMET 862. The sockets have an inner diameter of 2 mm for direct connection of a VEGACONNECT or other HART modems. The adjustment of the connected sensor is carried out via the VEGA Tools app or via PACTware and appropriate DTM.

Key functions

Key	Function
[OK]	Entry to the menu level Jump to selected menu item Edit parameter Save value
[>]	Switching between the individual measured value indications Navigation in the menu items Select editing position
[+]	Change parameter values
[ESC]	Jump to next higher menu Interrupt input

Time functions

When the [+] and [>] keys are pressed quickly, the edited value, or the cursor, changes one value or position at a time. If the key is pressed longer than 1 s, the value or position changes continuously. Approx. 60 minutes after the last pressing of a key, an automatic reset to measured value indication is triggered. Any values not confirmed with [OK] will not be saved.

7.2 Measured value/status and menu item display

Measured value indication

The measured value display shows the digital display value, the measuring loop name (measuring loop TAG) and the unit. In addition, an analogue bar graph can be displayed. Up to three measured value indications with a maximum three different measured values can be configured. If pump control is activated, an additional status bar with display of the assigned pumps is available.

Measured values are displayed according to the following presentation:

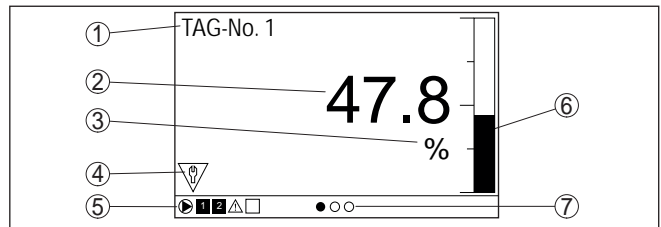

Fig. 12: Example measured value indication (measured value with bargraph)

- 1 Measurement loop name
- 2 Measured value
- 3 Unit
- 4 Status message acc. to NAMUR NE 107
- 5 Status bar for pump control
- 6 Bargraph measured value
- 7 Active measured value indication

Status display/background lighting

The display is equipped with a background lighting for better visibility. It serves simultaneously as a status display which is also visible from a great distance. The colour of the background lighting changes in the delivery status according to NAMUR NE 107.

- **White:** Error-free operation
- **Red:** Failure, error, fault
- **Orange:** Function check
- **Blue:** Maintenance required
- **Yellow:** Outside the specification

Alternatively, the status display can also show the switching status of the relays or measured value ranges individually with freely definable colours. Up to five measured value ranges, e.g., depending on the filling level, can be displayed in different colours. The background lighting can also be configured to flash in any colour as an additional signalling option.



Information:

This individual colour signalling is configured with PACTware/DTM or the VEGA Tools app.

Menu item display

The menu items are displayed according to the following presentation:

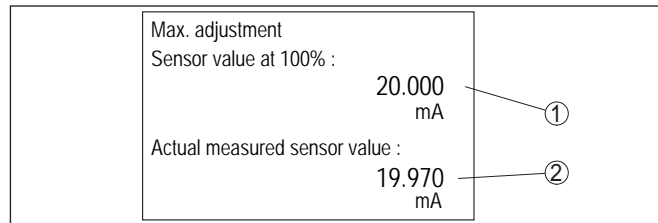

Fig. 13: Menu item display (example)

- 1 Sensor measured value at 100 %
- 2 Current sensor measured value

7.3 Menu overview

Measurement loop

Description	Basic settings
Sensor input	Selection 4 ... 20 mA or HART, allocation measuring point - input, deactivate measuring point 2
Damping	Time setting for damping
Linearisation	Linearization settings
Adjustment	Adjustment settings
Scaling	Scaling settings
Outputs	Relay/current output settings

Indication

Description	Basic settings
Number of measured value indications	Number of displayed measured value indications
Measured value indication	Settings for the measured value displays, automatic change of the measured value display
Options	Display options e.g. brightness, contrast, illumination
Menu language	Language settings

Extended functions

Description	Basic settings
Fail safe relay	Activate/deactivate fail safe relay
Access protection	Access protection for Bluetooth and protection of the parameter adjustment
Date/Time	Date and time settings
Reset	Reset of the device

Diagnostics

Description	Basic settings
Status	Status indication, e.g. device, sensor, relay
Simulation	Simulation function
Device-TAG	Display device name
Device information	Device information, e.g. serial number
Device memory	Copy device memory, remove/format SD card

7.4 Setup steps

Parameter adjustment

Through parameter adjustment, the instrument is adapted to the individual application conditions. A measurement loop calibration is the most important step and should always be carried out. A scaling of the measured value to the desired physical variable and unit, possibly including a linearisation curve, is often useful. The adaptation of the relay switching points or the setting of an integration time to smooth the measured value are further standard adjustment options.



Information:

When using PACTware and the respective DTM or the VEGA Tools app, additional settings can be carried out which are not possible or only partly possible with the integrated display and adjustment unit. Communication takes place via the built-in Bluetooth interface.

Applications

The device is configured ex works for universal applications. The following applications can be changed over and configured via the VEGA Tools app or the DTM:

- Universal
- Level storage tank
- Calculation difference

- Calculation total
- Calculation of average value
- Wells
- Pumping station
- Sewage screw lifting station
- Screen control
- Flow measurement flume/weir
- Density
- Pressurized vessel
- Overflow basin



Information:

An overview of the available applications and functions can be found in the appendix

Main menu

The main menu is divided into four areas with the following functions:

- **Measuring point:** Includes settings for adjustment, linearization, scaling, relay outputs, ...
- **Display:** Contains settings for display of measured values
- **Extended functions:** Includes settings for fail safe relay, access protection, reset, ...
- **Diagnosis** Includes information on device type/status, ...

7.4.1 Measurement loop

The VEGAMET 862 is designed for the connection of two independent sensors. Thus two independent measurements can be carried out. Furthermore, a third measuring point can be used to calculate a new value between the two input values.

Sensor input

The VEGAMET 862 can process measured values from 4 ... 20 mA/HART sensors via analogue communication as well as via digital HART protocol.

Analogue 4 ... 20 mA transmission

In the standard setting of VEGAMET 862 the measured value transmission is carried out via analogue 4 ... 20 signal. An adjustment in the sensor influences directly the input variable of VEGAMET 862. Only carry out the adjustment on one instrument, either on VEGAMET 862 or on the sensor. The adjustment in VEGAMET 862 is always carried out in mA (analogue transmission).

Digital HART transmission

For transmission via HART, VEGAMET 862 must be informed which sensor value should be used for further processing. Depending on the sensor type, this can be distance, pressure or temperature. With all HART sensors, the unchanged initial value of the sensor is always transmitted to VEGAMET 862. Thus, adjustment must always be carried out on VEGAMET 862, never on the sensor. Different parameters and measuring units are available. However, only one HART value per measuring point can be selected and displayed.

When connecting HART sensors, the following selection options are available, among others:

- PV (Primary Value)
- SV (Secondary Value)
- TV (Tertiary Value)
- QV (Quarterly Value)

The prerequisite for this is the support of the HART commands 0, 1, 3 and 15. This information and which measured values are transferred must be taken from the operating instructions manual of the respective sensor manufacturer.

After selecting the input type "HART", perform a sensor search first. All connected HART sensors are then listed and you can select the desired sensor. Then you can define the appropriate *Sensor value*. In the menu item "Sensor info" information such as sensor type, measuring range, serial number, HART address, measuring range, sensor TAG, ... are available.

Allocate sensor input

With the menu item "Sensor input" you can determine which of the two inputs is assigned to measurement loop 1 or measurement loop 2. The following assignment is factory set:

- Measuring point 1 -> Sensor input 1
- Measuring point 2 -> Sensor input 2

Deactivate measuring point 2

If measuring point 2 is not used, it can be deactivated using this function. This has the advantage that no fault message is issued if the sensor input is not connected.

Damping

To suppress fluctuations in the measured value display, e.g. caused by an agitated medium surface, an integration time can be set. This time can be between 0 and 999 seconds. Remember that the reaction time of the entire measurement will then be longer and the sensor will react to measured value changes with a delay. In general, a period of a few seconds is sufficient to smooth the measured value display.

Linearisation

A linearisation is necessary for all vessels in which the vessel volume does not increase linearly with the level, for example a horizontal cylindrical or spherical tank. Corresponding linearisation curves are preprogrammed for these vessels. They represent the correlation between the level percentage and vessel volume. By activating the appropriate curve, the volume percentage of the vessel is displayed correctly. If the volume should not be displayed in percent but e.g. in l or kg, a scaling can be also set.

When setting up a flow measurement, a linearization curve suitable for the structural conditions must be selected. Corresponding curves such as venturi, triangular overflow, ... are available here. In addition, individual, user-programmable linearisation curves can be stored via DTM.

Adjustment

Through the adjustment the input value of the connected sensor is converted into a percentage value. This conversion step allows any input value range to be depicted in a relative range (0 % up to 100 %).

The percentage values can be used for presentation on the display, for direct use in an output or for further conversion via linearization or scaling.

When using the display and adjustment unit, the adjustment unit is always "mA". When using PACTware/DTM or the VEGA Tools app, further units can be selected. If these have been activated, they are also shown in the display.

Min. adjustment (empty vessel)

If you want to use the currently measured level as a 0 %value, select the menu item "Accept" (live adjustment or adjustment with medium). If the adjustment is to be carried out independently of the measured level, select the option "Edit". Now enter the appropriate current in mA for the empty vessel (0 %) (dry adjustment or adjustment without medium).

Max. adjustment (full vessel)

If you want to use the currently measured level as a 100 %value, select the menu item "Accept" (live adjustment or adjustment with medium). If the adjustment is to be carried out independently of the measured level, select the option "Edit". Now enter the appropriate current in mA for the full vessel (100 %) (dry adjustment or adjustment without medium).

Scaling

Scaling means converting the measured value into a certain parameter and unit. The linearized percentage value is the source signal which is used as basis for the scaling. The indication can then show the volume in litres e.g., instead of the percentage value. Indication values from max. -9999999 to +9999999 are possible.

Outputs - Relay outputs

A total of six relays is available. Relays 1 ... 5 are freely available and not yet assigned to a function. To be able to use these relays, they must first be activated. Relay 6 is configured in the factory as a fail safe relay, but can also be configured as additional operating relay. After activating a relay output, the desired mode of operation must first be selected ("Overfill protection/Dry run protection").

- **Overfill protection:** Relay is switched off when the max. level is exceeded (safe currentless state), relay is switched on again when the level falls below the min. level (switch-on point < switch-off point)
- **Dry run protection:** Relay is switched off when the level falls below the min. level (safe currentless state), relay is switched on again when the max. level is exceeded (switch-on point > switch-off point)

Additional modes such as "Pump control", "Switching window", "Flow" and "Tendency" can be only set via PACTware/DTM or the VEGA Tools app.

In the menu item "Reference value" it is defined which measured value serves as input signal for the relay (percentage/lin.-percent/scaled).

Enter the values for switching the relay on and off under Enter the values for switching the relay on and off under " *Switching point*".

The menu item " *Behaviour in case of failure*" defines how the relay behaves if the assigned measuring point is disturbed. Here it can be selected whether the switching state of the relay remains unchanged or whether the relay is switched off in the event of a failure.

Outputs - Current output

The current output is used to transfer the measured value to a superordinate system, e.g. a PLC, a process control system or a measured value indication. This is an active output, i.e. the current is provided actively. The processing must hence have a passive current input. If the current output is not used, it can be deactivated in the first menu item.

The characteristics of the current output can be set to 0 ... 20 mA, 4 ... 20 mA or inverted. The reaction in case of failure can also be adapted to the requirements. The reference value you refer to can also be selected.

7.4.2 Indication

Number of measured value indications

The indication can display up to three different, user-configurable measured values simultaneously. In addition, up to three different measured value indications can be configured, which can be selected using the arrow keys. Alternatively, the display of the measured value indications can also be changed automatically at intervals of approx. 3 seconds.

In the menu item " *Display - Number of measured value indications*" you can configure how many measured value indications are to be displayed.

Measured value indication 1 ... 3

The content of the measured value indication is configured in the menu item " *Display - Measured value indication*". Up to 3 different measured values can be displayed in one indication. For each measured value it is also possible to configure which display value (percent, scaled, sensor value, ...) is displayed. In addition, the display format (number of decimal positions) can also be configured. In addition, a bar graph can be displayed parallel to the measured value (only available when displaying a single measured value).

Options - Brightness

In the menu item " *Display - Options - Brightness*" the brightness of the background lighting can be adjusted.

Options - Contrast

In the menu item " *Display - Options - Contrast*" the contrast of the display can be adjusted.

Options - Lighting

In the menu item " *Display - Options - Lighting*" the lighting can be set permanently to " *Permanently ON*" or " *Automatically OFF*" (after two minutes). With the setting " *Automatically OFF*" the lighting is switched on for two minutes as soon as any button is pressed.

Menu language

In the menu item " *Display - Menu language*", the requested language can be adjusted. The following languages are available:

- German
- English
- French
- Spanish
- Portuguese
- Italian
- Dutch
- Russian
- Chinese
- Japanese
- Turkish

7.4.3 Extended functions

Fail safe relay

Relay 6 can optionally be configured as additional operating relay or as a fail safe relay. In this menu item, the fail safe relay can be activated or deactivated. If relay 6 is to be configured as an operating relay, it must still be activated as an operating relay after deactivation as a fail safe relay. This is done in menu item " *Measuring point - Relay 6* "

Access protection - Bluetooth communication

Bluetooth communication can be activated/deactivated in this menu item. If Bluetooth communication is deactivated, a connection via app or DTM is no longer possible.

You can find further details in chapter " *Access protection* ".

Access protection - Bluetooth access code

Bluetooth communication is encrypted to prevent unauthorized access. The Bluetooth access code required for communication is displayed here and can be changed as required.



Note:

The individual, default Bluetooth access code of the device can be found on the device housing and on the supplied information sheet " *PINs and Codes* ". If this has been changed by the user and is no longer known, access is only possible via the emergency Bluetooth access code. You can find the emergency Bluetooth access code on the supplied information sheet " *Access protection* "

You can find further details in chapter " *Access protection* ".

Access protection - Protection of the parameter adjustment

The device parameters can be protected against unwanted or unintended changes by entering a device code.

With activated protection of the parameter adjustment, the individual menu items can be selected and displayed, however the parameters can no longer be modified.

Releasing the device adjustment is also possible in any menu item by entering the device code.



Note:

The default device code is " *000000* ". If this has been changed by the user and is no longer known, access is only possible via the emergency device code. You will find the emergency device code on the supplied information sheet " *Access protection* "



Caution:

With protected parameter adjustment, adjustment via the VEGA Tools app as well as PACTware/DTM and other systems is also blocked.

You can find further details in chapter " *Access protection*".

Date/Time

In this menu item the current date and time as well as the time format (24/12 hours) can be entered. These time settings are buffered by a capacitor and a battery for up to 10 years in the event of a power failure.

Reset

With a reset to basic setting, all settings except the display language and the Bluetooth access code are reset to factory settings. If desired, the device can also be restarted.

7.4.4 Diagnostics

Status

When the instrument displays a fault, further information about the fault can be called up via the menu item " *Diagnosis - Status*". Furthermore, the sensor status with input current as well as the digital inputs can be displayed. The status of the relay, its switched-on period and the number of switch-on events can also be displayed. The counters can also be reset.

Simulation

The simulation of a measured value is used to check the outputs and connected components. It can be applied to the sensor value, the percentage value, the lin. percentage value as well as the scaled value.



Note:

Please note that downstream plant components (valves, pumps, motors, controls) are influenced by the simulation, which can lead to unintentional plant operating states. The simulated value is output until you deactivate the simulation mode again. The simulation is automatically terminated after approx. 60 minutes.

Device-TAG

You can assign an unambiguous name to VEGAMET 862 to the Device-TAG via DTM/VEGA Tools app. This function is recommended when several instruments are implemented and a good documentation of larger systems is required.

Device information

The menu item " *Device information*" provides the device name and serial number as well as the hardware and software version.

Device memory

The measured values saved on the internal device memory can also be copied to an SD card inserted in the device. To do this, use the menu item " *Copy to SD card*".

With the menu item " *Format SD card*" you can carry out a FAT32 formatting of the inserted SD card. The SD card inserted in the factory is already formatted.

Before removing an inserted SD card, use the " *Remove SD card safely*" function to remove the card safely and without data loss from the device.

Further information on saving measured values can be found in chapter " *Measured value memory/data logger*".

8 Setup with smartphone/tablet (Bluetooth)

8.1 Preparations

System requirements

Make sure that your smartphone/tablet meets the following system requirements:

- Operating system: iOS 8 or newer
- Operating system: Android 5.1 or newer
- Bluetooth 4.0 LE or newer

Download the VEGA Tools app from the "Apple App Store", "Google Play Store" or "Baidu Store" to your smartphone or tablet.

8.2 Connecting

Connecting

Start the VEGA Tools app and select the function "Setup". The smartphone/tablet searches automatically for Bluetooth-capable instruments in the area.

The devices found are listed and the search is automatically continued.

Select the requested instrument in the device list.

As soon as the Bluetooth connection to a device is established, the LED display of the device in question flashes blue 4 times.

The message "Connecting ..." is displayed.

Authenticate

When establishing the connection for the first time, the operating tool and the controller must authenticate each other. After the first correct authentication, each subsequent connection is made without a new authentication query.

Enter Bluetooth access code

For authentication, enter the 6-digit Bluetooth access code in the next menu window. You can find the code on the outside of the device housing and on the information sheet "Pins and Codes" in the device packaging.

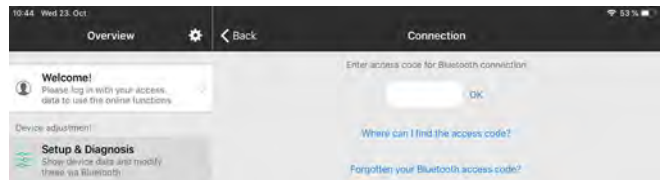

Note:

If an incorrect code is entered, the code can only be entered again after a delay time. This time gets longer after each incorrect entry.

The message "Waiting for authentication" is displayed on the smartphone/tablet.

Connected

After connection, the adjustment menu is displayed on the respective adjustment tool.

If the Bluetooth connection is interrupted, e.g. due to a too large distance between the two devices, this is displayed on the adjustment tool. The message disappears when the connection is restored.

Change device code

Parameter adjustment of the device is only possible if the parameter protection is deactivated. When delivered, parameter protection is deactivated by default and can be activated at any time.

It is recommended to enter a personal 6-digit device code. To do this, go to menu " *Extended functions*", " *Access protection*", menu item " *Protection of the parameter adjustment*".

8.3 Parameter adjustment

Enter parameters

The adjustment menu is divided into two halves:

On the left you will find the navigation area with the menus " *Setup*", " *Extended functions*" as well as " *Diagnosis*".

The selected menu item, recognisable by the colour change, is displayed in the right half.



Fig. 14: Example of an app view - Setup adjustment

Enter the requested parameters and confirm via the keyboard or the editing field. The settings are then active in the device.

Close the app to terminate connection.

9 Setup with PC/notebook (Bluetooth)

9.1 Preparations

System requirements

Make sure that your PC/notebook meets the following system requirements:

- Operating system Windows 10
- DTM Collection 10/2020 or newer
- Bluetooth 4.0 LE or newer

Activate Bluetooth connection

Activate the Bluetooth connection via the project assistant.



Note:

Older systems do not always have an integrated Bluetooth LE. In these cases, a Bluetooth USB adapter is required. Activate the Bluetooth USB adapter using the Project Wizard.

After activating the integrated Bluetooth or the Bluetooth USB adapter, devices with Bluetooth are found and created in the project tree.

9.2 Connecting

Connecting

Select the requested device for the online parameter adjustment in the project tree.

Authenticate

When establishing the connection for the first time, the operating tool and the controller must authenticate each other. After the first correct authentication, each subsequent connection is made without a new authentication query.

Enter Bluetooth access code

For authentication, enter in the next menu window the 6-digit Bluetooth access code:

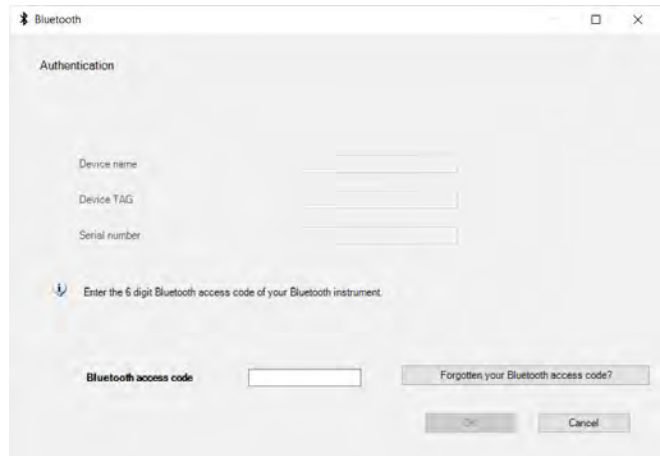

You can find the code on the information sheet "PINs and Codes" in the device packaging:

**Note:**

If an incorrect code is entered, the code can only be entered again after a delay time. This time gets longer after each incorrect entry.

The message "Waiting for authentication" is displayed on the PC.

Connected

After connection, the DTM appears.

If the connection is interrupted, e.g. due to a too large distance between controller and PC, this is displayed on the PC. The message disappears when the connection is restored.

Change device code

Parameter adjustment of the device is only possible if the parameter protection is deactivated. When delivered, parameter protection is deactivated by default and can be activated at any time.

It is recommended to change the factory default 6-digit device code "000000" to your personal 4 - 10-digit device code. Go to the menu "Extended functions", "Access protection", menu item "Protection of the parameterization".

9.3 Parameter adjustment**Prerequisites**

For parameter adjustment of the instrument via a Windows PC, the configuration software PACTware and a suitable instrument driver (DTM) according to FDT standard are required. The latest PACTware version as well as all available DTMs are compiled in a DTM Collection. The DTMs can also be integrated into other frame applications according to FDT standard.

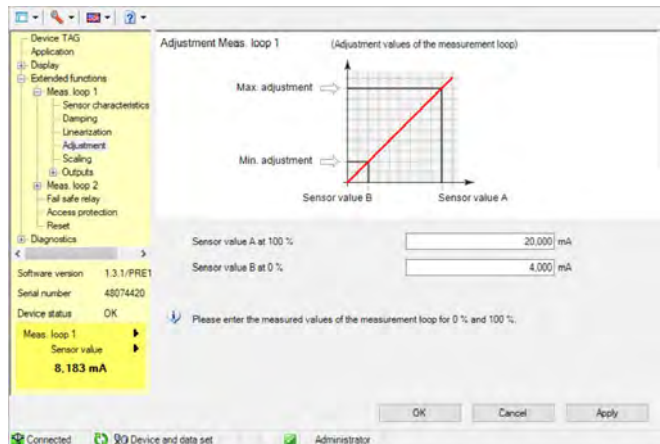

Fig. 15: Example of a DTM view - Adjustment

10 Measured value memory/data logger

With the measured value memory, the measured values of each measuring point and the 4 ... 20 mA/HART sensors connected to it can be recorded and monitored. There are two different options for recording measured values:

Measured value memory

The data are saved over a certain period in the instrument and can be read out again later on. Via PACTware and DTM different recording conditions can be set and the process can be started or stopped. The max. recording period is limited by the memory of the controller. The max. recording period differs depending on the recording type (interval or measured value difference).

When recording with interval, a total of 260,000 measured values can be recorded; when recording with measured value difference, the value is reduced to 200,000. If measured values are stored at intervals of, for example, one minute, this results in a duration of 180 days. If more than one curve is recorded, this time is reduced accordingly. If the data is automatically copied to the SD card every day, more than 100 million measured values can be stored on the factory 8 GB SD card.



Note:

The recorded data are written in an interval of two to five minutes of the internal flash disk. In case of voltage failure, recordings of the last minutes can get lost.

Measured value memory (DTM)

The data are only saved on the PC during an online connection with PACTware and DTM. The max. recording period is limited only by the storage space on the hard disc.

10.1 Setting the measured value memory

The settings are carried out in the DTM under the menu item "*Diagnostics - Measured value memory - Settings*". Up to 3 curves are available. If required, these curves are activated or deactivated/deleted on this side. By pushing the button "*Add*", an installation assistant for creating the selected curve is started. The following settings are carried out step-by-step:

Measurement loop/Measured value

In the first step you have to select the requested measurement loop and the measured value.

Recording mode

Here you set the requested recording interval. The following options are possible:

- "*In time interval*": Recording is carried out in certain adjustable time intervals
- "*With measured value difference*": Recording is carried out measured value dependent with adjustable measured value difference

A combination of the two recording modes is also possible.

Start/Stop conditions

To enable a specific monitoring, the start and stop conditions can be set for the recording in dependence on the current measured value.

If a start condition is met, the recording starts in the instrument. The current recording is stopped as soon as the stop condition is reached (pause function). When the start condition is met again, the recording continues.

**Note:**

If the recording is started, previously recorded values of this curve are deleted.

The recording can be stopped automatically if the memory in the VEGA instrument is full. Select the option "*Stop recording when memory is full*". If this option is selected, the older measured values will be overwritten automatically (ring buffer).

10.2 Start of the recording

After having adjusted the recording mode and the start/stop conditions, these settings have to be transferred to the instrument ("*Device data - Save in device*"). Activate the trend recording by pushing the button "*Start recording*". The current utilisation of the memory and the number of recorded measured values is now displayed under "*Status*". Modification of the recording conditions is not possible during a recording.

10.3 Load recording from device

To load a saved curve from the device, select the page "*Diagnosis - Device memory - Measured value memory(device)*" and click with the right mouse key to the diagram. Select in the opening popup menu the entry "*Load recording from device*". A dialogue window opens in which the curve and the range can be selected. In the list box for selecting the curve, all curves are shown which are currently activated in the controller. Under "*Range*" you see the available range on the right which can be limited by the fields "*Begin*" and "*End*". Through this, the time required for reading out the curve can be considerably reduced.

Further information on trend recording is available in the online help of the corresponding DTM.

10.4 Save to SD card

The measured values are always stored in the internal memory of the device and can be read out again via the DTM. In addition, the recorded measured values can be copied to the microSDHC memory card supplied by the factory as a CSV or GND file. This has the advantage that the memory card can be removed and the recorded values accessed elsewhere. The evaluation of the curves in GND format is made with the software VEGA Data Viewer (part of the full version of the VEGA DTM Collection).

Copying to the SD card can be done either manually or automatically. The manual copying of the entire internal measured value memory can be started via the display and adjustment module. A separate CSV file is created for each existing curve. The automatic copying process (daily at any time) is configured via DTM/app. The internal

measured value memory since the last copy procedure is always saved in a new CSV or GND file.

The file name created during copying has the following format: "*Serial number of the controller_CRV-curve number_Date_Time*", i.e. "*12345678_CRV001_2020-09-24_15-00-13.csv*". This file is copied to the following directory on the SD card: "*/backup/measured_value*".

The card reader is only accessible when the housing is open. It is located under the display cover and is labelled "*SD Card*".



Note:

The memory card may only be removed if it has previously been safely removed from the system via the menu item "*Diagnosis - Device memory*".

10.5 Format SD card

With the menu item "*Format SD card*" a FAT32 formatting of the inserted SD card can be carried out. In addition, the file "*device_info.txt*" is created on the card, which contains specific information about your device (device type, serial number, hardware/software version, calibration date). The SD card inserted in the factory is already formatted.

11 Applications and functions

The controller contains already preset applications and functions, which can be easily adjusted by means of an application assistant via PACTware/DTM or the VEGA Tools app. The following applications/functions are described here as examples.

- Level measurement in storage tanks with overflow protection/dry run protection
- Pump station with pump control function
- Screen control
- Flow measurement flume/weir

11.1 Level measurement in storage tanks with overflow protection/dry run protection

Application

The level is detected by a sensor and transmitted to the controller by means of a 4 ... 20 mA signal. Here, an adjustment is carried out, converting the input value delivered by the sensor into a percentage value.

Depending on the geometrical form of the tank, the vessel volume does not increase linearly with the level, e.g. with an horizontal cylindrical tank. This can be compensated by selecting the linearisation curve integrated in the instrument. This curve states the relationship between percentage level and vessel volume. If the level is to be displayed in litres, a scaling must also be carried out. For this purpose, the linearised percentage value is converted into a volume, for example with the unit litre.

Filling and emptying are controlled via relay 1 and 2 which are integrated in the controller. During filling, relay mode "*Overflow protection*" is set. The relay is thus switched off (safe currentless state) when the max. level is exceeded, and switched on again when the min. level is underrun (switch-on point < switch-off point). During emptying, mode "*Dry run protection*" is used. This relay is thus switched off when the min. level is underrun (safe currentless condition), and switched on again when the max. level is exceeded (switch-on point > switch-off point).

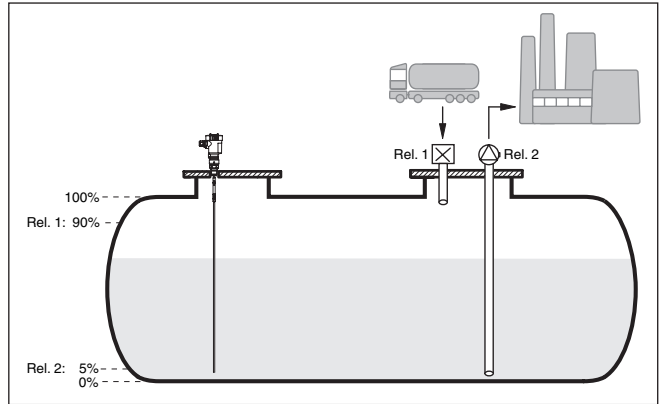

Fig. 16: Example of level measurement, horizontal cylindrical tank

11.1.1 Setup

An application wizard guides you through the most common selection possibilities. Further application options are available on the corresponding DTM/app pages. A more detailed description of all available application options is included in the DTM online help.

The following steps must be carried out in the application wizard:

Select application

Select the application "Level storage tank" from the options offered.

Assign measuring loop name

Assign a unique designation to the measuring point so that there can be no confusion with other measuring points.

Select sensor input

Define how the measured value should be transmitted between sensor and controller (4 ... 20 mA or HART). With HART selection, the desired sensor must also be selected. If HART is also available for the sensor, the HART selection should be used, as higher accuracy can be achieved here.

Define sensor characteristic values

When using analogue 4 ... 20 mA sensors, the measuring range suitable for the application should be set directly in the sensor to achieve maximum accuracy. This measuring range must now be stored once again in the assistant together with the sensor type and the measuring unit.

When using HART sensors, only the desired sensor value with unit must be defined.

Linearisation

Select the suitable linearization type (linear, cylindrical tank, spherical tank) depending on your vessel.

Define adjustment values

Enter the adjustment values of the measuring point for 0 % and for 100 %.

Scaling

Enter the measured value and unit (e.g. volume and m³) and the corresponding scaling values for 100 % and 0 % (e.g. 100 m³, 0 m³).

Configure relay

First select the requested mode for the relay ("*Overflow protection, dry run protection, switching window ON/OFF*"). Also define the appropriate reference value ("*Percent, Lin.-percent, Scaled*") as well as the behaviour in case of failure ("*Switching status OFF, hold value*"). Finally, assign the values for the upper and lower switching point.

Configure measured value indication

In the last step you can configure which and how many measured values are to be shown on the display. In addition, you can define the base of the display value, the display format and the optional bar graph.

11.1.2 Application example**Description**

A horizontal cylindrical tank has a capacity of 10000 litres. The measurement is carried out with a level sensor operating according to the guided microwave principle. The filling by a tank car is controlled via relay 1 and a valve (overflow protection). The discharge is carried out via a pump and is controlled by relay 2 (dry run protection). The max. volume should be at 90 % level, this means 9475 litres with a standard vessel. The min. level should be set to 5 %, this corresponds to 194 litres. The volume is to be displayed in litres.

Linearisation

To display the percentage level correctly, select under "*Measurement loop - Linearization curve*" the entry "*Horiz. cylindrical tank*".

Adjustment

Carry out the adjustment in the controller as described in chapter "*Setup steps*". No further adjustment may be carried out in the sensor itself. For the max. adjustment, fill the vessel up to the requested max. level and accept the actually measured value. If this is not possible, the corresponding sensor value can also be entered. For the min. adjustment, empty the vessel down to the min. level or enter the corresponding sensor value.

Scaling

To display the volume in litres, you have to enter "*Volume*" as the unit in litres under "*Measurement loop - Scaling*". The allocation is then carried out, in this example 100 % \triangleq 10000 litres and 0 % \triangleq 0 litres.

Relay

Percent is selected as reference value for the relays. The mode of relay 1 is set to overflow protection, relay 2 must be activated and gets mode dry run protection. To ensure that the pump switches off in case of failure, the reaction in case of failure should be set to switching status OFF. The switching points are set as follows:

- **Relay 1:** Switch-off point 90 %, switch-on point 85 %
- **Relay 2:** Switch-off point 5 %, switch-on point 10 %



Information:

The switch-on and switch-off point of the relays must not be set to the same switching point because this would cause a continuous switching on and off when this threshold is reached. To avoid this effect also with fluctuating medium surfaces, it is a good idea to set a difference (hysteresis) of 5 % between the switching points.

11.2 Pump station with pump control function

Application description

The waste water from households and industry, together with surface water, is fed to the sewage treatment plant via an extensive network of sewers. If the natural gradient is not sufficient, various pumping stations are required to compensate for the differences in height. The level measurement in the inlet shaft serves for the economic control of the pumps. The intelligent control of several pumps can be easily adjusted by the controller.

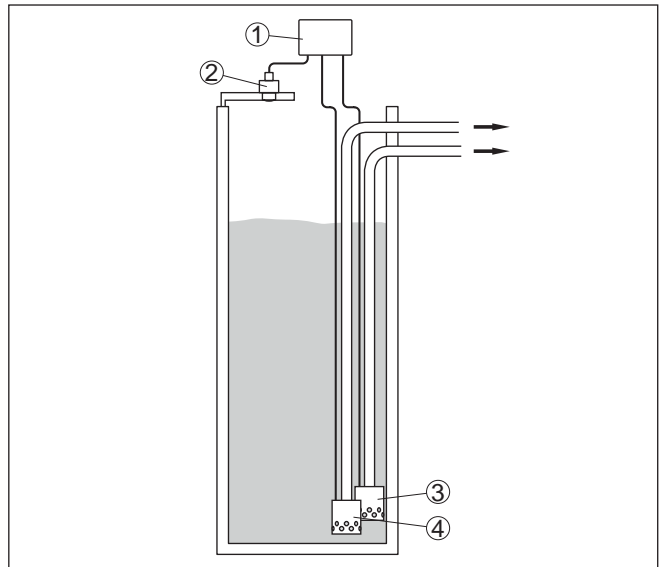

Fig. 17: Example pumping station: Pump control in the inlet shaft

- 1 VEGAMET 862
- 2 Radar sensor
- 3 Pump 1
- 4 Pump 2

Display indication

When pump control is activated, the assigned relays and possible pump malfunctions are also displayed in the status bar of the measured value indication.

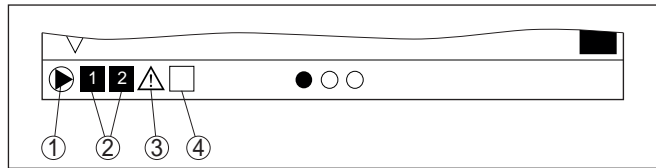

Fig. 18: Example of a display status bar with activated pump control

- 1 Symbol, activated pump control
- 2 Relay 1 and 2 are assigned to the pump control
- 3 Relay 3 is assigned to the pump control and signals failure
- 4 Relay is free i.e. not assigned to the pump control

11.2.1 Setup

The application wizard guides you through the various configuration possibilities and options. The following steps are performed:

Select application

Select the application "Pumping station" from the options offered.

Assign measuring loop name

Assign a unique designation to the measuring point so that there can be no confusion with other measuring points.

Select sensor input

Define how the measured value should be transmitted between sensor and controller (4 ... 20 mA or HART). With HART selection, the desired sensor must also be selected. If HART is also available for the sensor, the HART selection should be used, as higher accuracy can be achieved here.

Define sensor characteristic values

When using analogue 4 ... 20 mA sensors, the measuring range suitable for the application should be set directly in the sensor to achieve maximum accuracy. This measuring range must now be stored once again in the assistant together with the sensor type and the measuring unit.

When using HART sensors, only the desired sensor value with unit must be defined.

Define adjustment values

Enter the adjustment values of the measuring point for 0 % and for 100 %.

Define mode of operation of the pump control

Define the desired operating mode of the pump control: pump control 1/2 (same running time) or pump control 3/4 (fixed sequence). In addition, you can select the mode sequenced or alternating pump operation. The setup wizard and the following application examples provide you with details on how it works.

Configure pumps

In this step a forced pump changeover can be activated. For devices with a digital input, additional monitoring of the pumps can be con-

figured. The setup assistant and the following application examples provide you with details on how it works.

Configure relay switching points

Enter the relay switching points at which the pumps should be switched.

Configure measured value indication

In the last step you can configure which and how many measured values are to be shown on the display. In addition, you can define the base of the display value, the display format and the optional bar graph.

11.2.2 Application example pump control 1/2

Functional principle

Pump control 1/2 is used to control several pumps with the same function, in dependence on their respective elapsed running times. The pump with the shortest elapsed running time is switched on and the pump with the longest running time switched off. In case of increased pumping requirement, all pumps can also run at the same time, in dependence on the entered switching points. This measure achieves an even utilization of the pumps and increases operational reliability.

All relays with activated pump control are switched on or off depending on the accumulated operating time. The controller selects the relay with the shortest elapsed operating time when the switch-on point is reached and the relay with the longest elapsed operating time when the switch-off point is reached.

Pump fault messages can also be processed via the digital inputs.

This pump control system offers two different options:

- **Pump control 1:** The upper switching point determines the switch-off point for the relay, whereas the lower switching point determines the switch-on point
- **Pump control 2:** The upper switching point determines the switch-on point for the relay, whereas the lower switching point determines the switch-off point

Example

Two pumps should empty the vessel when a certain level is reached. At 80 % filling, the pump with the shortest elapsed running time should switch on. If the level nevertheless increases, a second pump should switch on at 90 %. Both pumps should switch off again at 10 % filling.

For relay 1 and 2, the mode of operation "*Pump control 2*" is adjusted with the option "*Sequenced operation*". The relay switching points are configured as follows:

- Relay 1 upper switching point = 80.0 %
- Relay 1 lower switching point = 10.0 %
- Relay 2 upper switching point = 90.0 %
- Relay 2 lower switching point = 10.0 %

The function of pump control 2 is shown in detail in the following diagram. The previously described example is used as a basis.

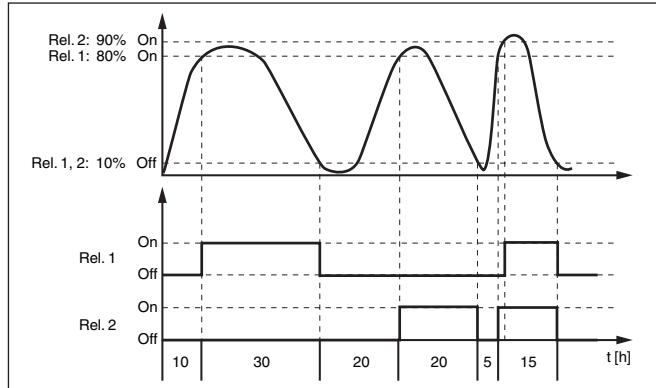

Fig. 19: Example of pump control 2

Option Dry weather pump

Pump control 2/4 with dry weather pump is used to protect e.g. rain retention basins with different sized pumps against overflowing. Normally (in fair weather), a pump with low capacity (dry weather pump) is sufficient to maintain the level in the retention basin at a safe level (Hi-Level). If heavy rainfall causes an increased inflow, the fair weather pump can no longer maintain the level. In such cases, a larger pump is switched on when the HiHi level is exceeded and the dry weather pump is switched off. The large pump then remains in operation until the switch-off point is reached. If the level rises again, the dry weather pump switches back on first.

There is also the possibility of using multiple large pumps in alternating mode. The algorithm for the switching function is then determined by the pump control mode.

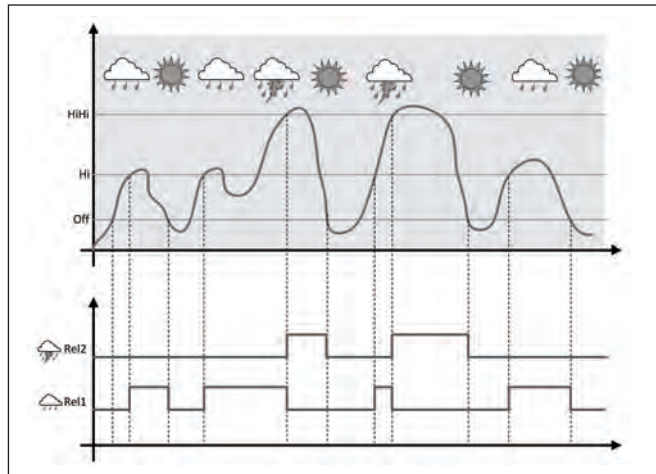

Fig. 20: Example of a pump control with option "Dry weather pump"

58867-EN-210818

**Note:**

If the option "Dry weather pump" is activated, only the mode "Alternating pump operation" will be available, i.e. only one pump at a time is in operation.

Pump control mode

The pump control system offers the possibility to choose between sequenced and alternating pump operation:

- **Sequenced operation:** Depending on the switching points, all pumps are switched on one after the other, i.e. the max. number of pumps that can be switched on corresponds to the number of assigned relays
- **Alternating pump operation:** Independent of the switching point, only one pump at a time is switched on

Option, forced switchover

If the level has not changed over a longer period, the same pump would always remain switched on. Via the parameter "Switchover time", a time can be preset which, after it is elapsed, forces a switchover of the pump. Which pump is switched on depends on the selected pump mode. If all pumps are already switched on, the pump remains switched on.

**Note:**

If the pump is already switched on when the forced switchover is activated, the timer is not started. Only after the pump is switched off and on again will the timer start. If a switch-off delay is set, it will not be taken into account, i.e. the switchover is carried out exactly after the preset time for the forced switchover expires. A preset switch-on delay, however, is taken into account, i.e. the forced switchover to another pump is carried out after the preset time expires. Before the newly selected pump switches on, the preset switch-on delay for this pump must have expired.

Pump monitoring

With a pump control, there is also the possibility of switching on pump monitoring. For this purpose, a feedback signal is required on the respective digital input. The digital inputs are assigned 1:1 to the relays. Digital input 1 acts on relay 1, etc.

The following two operating modes are available for pump monitoring:

- Pump monitoring with pump checkback
- Pump monitoring with pump stand-by

Pump monitoring with pump checkback

If the pump monitoring for a relay was switched on, a timer is started when the relay is switched on (time allowance with parameter "Report time"). If the checkback signal comes from the pump on the respective digital input within the defined report time, the pump relay remains energized, otherwise the relay is immediately switched off and a fault signal outputted. A fault signal and a switching off of the relay is carried out even if the relay is already switched on and the pump checkback signal changes during the running time of the pump. In addition, a switched-off relay of the pump control is looked for and switched on instead of the faulted relay. A Low signal on the digital in-

put is evaluated as a pump error signal. To cancel the fault message, the signal at the digital input must change to "Good".

Pump monitoring with pump stand-by

The mode of operation corresponds to "Pump monitoring with pump checkback" with the difference that in this mode of operation no fault message is output, but only the NAMUR status "Maintenance required". If the pump is not ready (e.g. maintenance mode), this can be signalled via the digital input, only the NAMUR status "Maintenance required" is output and no fault message. The other connected pumps are then automatically used for pump control until the pump is ready for maintenance again.

11.2.3 Application example pump control 3/4

Functional principle

Pump control 3/4 is used to control several pumps with the same function alternately and in a fixed sequence. In case of increased pumping requirement, all pumps can also run at the same time, in dependence on the entered switching points. This measure achieves an even utilization of the pumps and increases operational reliability.

All relays with activated pump control are not assigned to a certain switching point but are switched on and off alternately. When a switch-on point is reached, the controller selects the relay that is next in the sequence. When a switch-off point is reached, the relays are switched off in the sequence they were switched on.

This pump control system offers two different options:

- Pump control 3: The upper switching point determines the switch-off point for the relay, whereas the lower switching point determines the switch-on point
- Pump control 4: The upper switching point determines the switch-on point for the relay, whereas the lower switching point determines the switch-off point

The sequence cannot be changed, the relay with the lowest index is switched on first, then the relay with the next higher index. After the relay with the highest index, the relay with the lowest index follows, for example Rel. 1 -> Rel. 2 -> Rel. 3 -> Rel. 1 -> Rel. 2 ...

The sequence applies only to those relays assigned to the pump control.

Example

In a waste water disposal system, a sump should be pumped empty when a certain level is reached. Three pumps are available for this. At 60 % level, pump 1 should run until the level has fallen below 10 %. If the 60 % point is exceeded again, the same task is transferred to pump 2. In the third cycle, pump 3 is activated; after that, pump 1 again. If the level continues to rise despite operation of a pump, an additional pump switched on when the level exceeds the 75 % switching point. And if the level still rises further due to extreme inflow and exceeds the 90 % limit, pump 3 is also switched on.

For relay 1 ... 3, the mode of operation "Pump control 4" is adjusted with the option "Sequenced operation". The relay switching points are configured as follows:

Select in the DTM navigation section the menu items " *Meas. loop - Outputs - Relay*".

- Relay 1 upper switching point = 60.0 %
- Relay 1 lower switching point = 10.0 %
- Relay 2 upper switching point = 75.0 %
- Relay 2 lower switching point = 10.0 %
- Relay 3 upper switching point = 90.0 %
- Relay 3 lower switching point = 10.0 %

The function of pump control 4 is shown in detail in the following diagram. The previously described example is used as a basis.

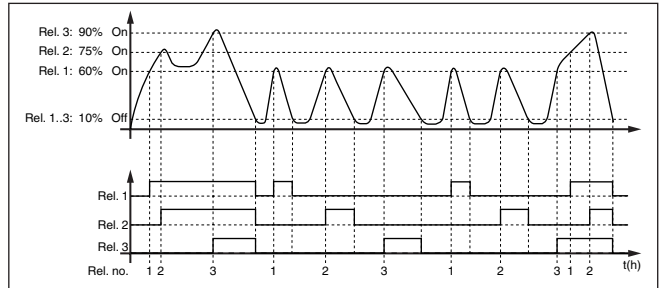

Fig. 21: Example of pump control 4

Option Dry weather pump

Pump control 2/4 with dry weather pump is used to protect e.g. rain retention basins with different sized pumps against overflowing. Normally (in fair weather), a pump with low capacity (dry weather pump) is sufficient to maintain the level in the retention basin at a safe level (Hi-Level). If heavy rainfall causes an increased inflow, the fair weather pump can no longer maintain the level. In such cases, a larger pump is switched on when the HiHi level is exceeded and the dry weather pump is switched off. The large pump then remains in operation until the switch-off point is reached. If the level rises again, the dry weather pump switches back on first.

There is also the possibility of using multiple large pumps in alternating mode. The algorithm for the switching function is then determined by the pump control mode.

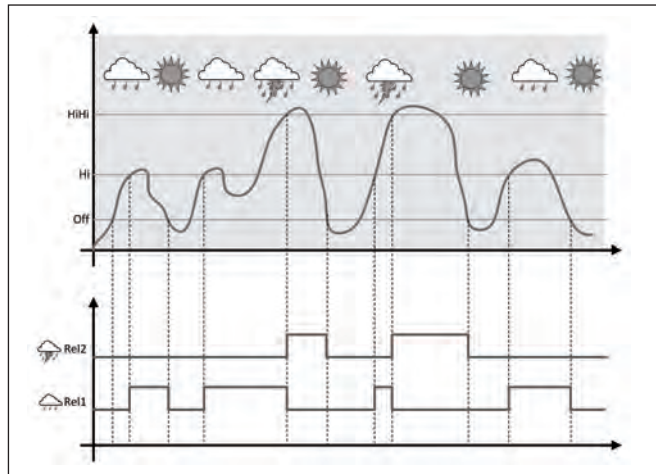

Fig. 22: Example of a pump control with option "Dry weather pump"



Note:

If the option "Dry weather pump" is activated, only the mode "Alternating pump operation" will be available, i.e. only one pump at a time is in operation.

Pump control mode

The pump control system offers the possibility to choose between sequenced and alternating pump operation:

- **Sequenced operation:** Depending on the switching points, all pumps are switched on one after the other, i.e. the max. number of pumps that can be switched on corresponds to the number of assigned relays
- **Alternating pump operation:** Independent of the switching point, only one pump at a time is switched on

Option, forced switchover

If the level does not change over a longer period of time, the same pump would remain switched on. Via the parameter "Changeover time", a time period can be preset, after which a forced changeover of the pump is carried out. This function is described under pump control 1/2.

Diagnosis via running time

If all pumps have the same capacity and are used for the same task alternately, the running time should always be roughly the same. The respective operating hours are summed up individually in the controller and can be read out in the menu "Diagnosis - Status - Relay". If a large difference between the pumps is determined, the capacity of one of the pumps must have fallen considerably. This information can be consulted for diagnosis and service, e.g. to recognize plugged-up filters or worn out bearings.

Since in this case all pumps operate alternately in the same area, their switch-on and switch-off points must be the same. In addition, the mode "Alternating pump operation" must be active.



Note:

The number of the last switched-on relay is not saved in case of voltage loss, this means that after the controller is switched back on again, the relay with the shortest running time always starts first.

Pump monitoring

The description of the pump monitoring can be found at pump control 1/2, the function is exactly identical.

11.3 Screen control

Application

In the mechanical pre-cleaning of a hydropower plant, floating solids are removed with screens or sieves. The subsequent process stages are thus protected from sedimentation, clogging or abrasion. Large solids are screened out in the coarse screen, compressed in the screening press and then disposed of. The fine screen removes the smaller residues from the waste water. The differential measurement of the water level in front of and behind the screen determines the degree of pollution and initiates the cleaning of the screen. Two sensors can be connected simultaneously to the two-channel controller and the differential measurement can be easily adjusted. Relay outputs can be used for calculation control and several current outputs for signal processing.

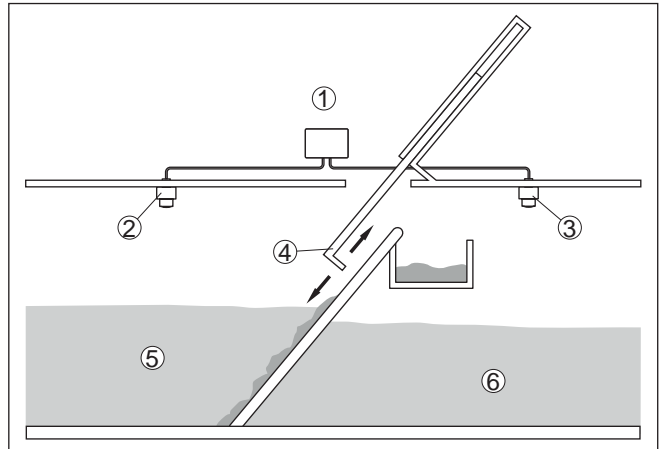

Fig. 23: Example of a screen control

- 1 VEGAMET 862
- 2 Radar sensor 1
- 3 Radar sensor 2
- 4 Screen
- 5 Upstream water
- 6 Tailwater

11.3.1 Setup

An application wizard guides you through the most common selection possibilities. Further application options are available on the corre-

sponding DTM/app pages. A more detailed description of all available application options is included in the DTM online help.

The following steps must be carried out in the application wizard:

Select application

Select the application "*Screen control*" from the options offered.

Assign measuring loop name

Assign a unique designation to the measuring point so that there can be no confusion with other measuring points.

Select sensor input measuring point 1

Define how the measured value should be transmitted between sensor and controller (4 ... 20 mA or HART). With HART selection, the desired sensor must also be selected. If HART is also available for the sensor, the HART selection should be used, as higher accuracy can be achieved here.

Sensor characteristic values - define measuring point 1

When using analogue 4 ... 20 mA sensors, the measuring range suitable for the application should be set directly in the sensor to achieve maximum accuracy. This measuring range must now be stored once again in the assistant together with the sensor type and the measuring unit.

When using HART sensors, only the desired sensor value with unit must be defined.

Select sensor input measuring point 2

Define how the measured value should be transmitted between sensor and controller (4 ... 20 mA or HART). With HART selection, the desired sensor must also be selected. If HART is also available for the sensor, the HART selection should be used, as higher accuracy can be achieved here.

Sensor characteristic values - define measuring point 2

When using analogue 4 ... 20 mA sensors, the measuring range suitable for the application should be set directly in the sensor to achieve maximum accuracy. This measuring range must now be stored once again in the assistant together with the sensor type and the measuring unit.

When using HART sensors, only the desired sensor value with unit must be defined.

Adjustment values - define measuring point 1

Enter the adjustment values of the measuring point for 0 % and for 100 %.

Adjustment values - define measuring point 2

Enter the adjustment values of the measuring point for 0 % and for 100 %.

Scaling - define measuring point 3

Enter the desired measured value, measuring unit and display format and the appropriate scaling values for 0 % and 100 %.

Configure relay switching points

Enter the relay switching points at which the pumps should be switched.

Configure measured value indication

In the last step you can configure which and how many measured values are to be shown on the display. In addition, you can define the base of the display value, the display format and the optional bar graph.

11.4 Flow measurement flume/weir**Application**

Waste water and rainwater are often transported to the sewage treatment plant in open collection channels. The flow rate is measured at various points in the collection channels. For flow measurement in open waters, a constriction or a standardised channel must be used. This constriction creates a certain backwater depending on the flow rate. The flow rate can now be derived from the level of this backwater.

The current flow rate is shown on the display in the selected unit of measurement (e.g. m³/h). In addition, the flow rate is made available via the current output and can thus be further processed by downstream devices.

It is also possible to totalize the flow rate by means of a totalizer, the result is shown on the display (e.g. in m³). In addition, the flow rate can be output via a corresponding number of pulses on the relay/current output (flow rate pulse). A sampling pulse can also be configured.

Flume

Every flume generates a different level of backwater depending on its type and version. The specifications of the following flumes are available in the instrument:

Predefined curves

A flow measurement with these standard curves is very easy to set up, as no dimensional information of the flume is required.

- Palmer-Bowlus flume ($Q = k \times h^{1.86}$)
- Venturi, trapezoidal weir, rectangular flume ($Q = k \times h^{1.5}$)
- V-Notch, triangular overfall ($Q = k \times h^{2.5}$)

Dimensions (ISO standard)

When selecting these curves, the dimensions of the flume must be known and entered via the assistant. As a result, the accuracy of the flow measurement is higher than with the specified curves.

- Rectangular flume (ISO 4359)
- Trapezoidal flume (ISO 4359)
- U-shaped flume (ISO 4359)
- Triangular overfall thin-walled (ISO 1438)
- Rectangular flume thin-walled (ISO 1438)
- Rectangular weir broad crown (ISO 3846)

Flow formula

If the flow formula of your flume is known, you should select this option, as the accuracy of the flow measurement is highest here.

- Flow formula: $Q = k \times h^{\text{exp}}$

Manufacturer definition

If you use a Parshall flume from the manufacturer ISCO, this option must be selected. This gives you a high accuracy of flow measurement with easy configuration.

Alternatively, you can also take over Q/h table values provided by the manufacturer here.

- ISCO Parshall flume
- Q/h table (assignment of height with corresponding flow in a table)

Example rectangular flume

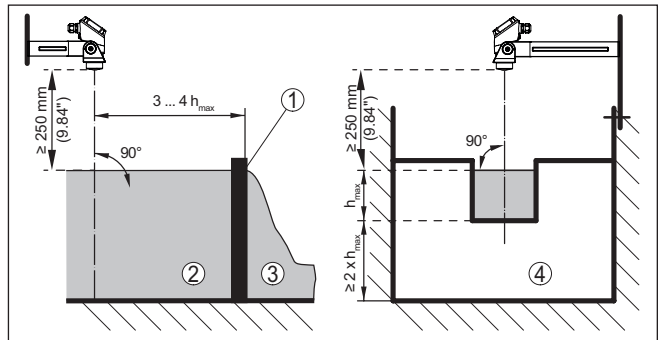

Fig. 24: Flow measurement with rectangular flume: $h_{\text{max}} = \text{max. filling of the rectangular flume}$

- 1 Overfall orifice (side view)
- 2 Upstream water
- 3 Tailwater
- 4 Overfall orifice (view from tailwater)

Example Khafagi Venturi flume

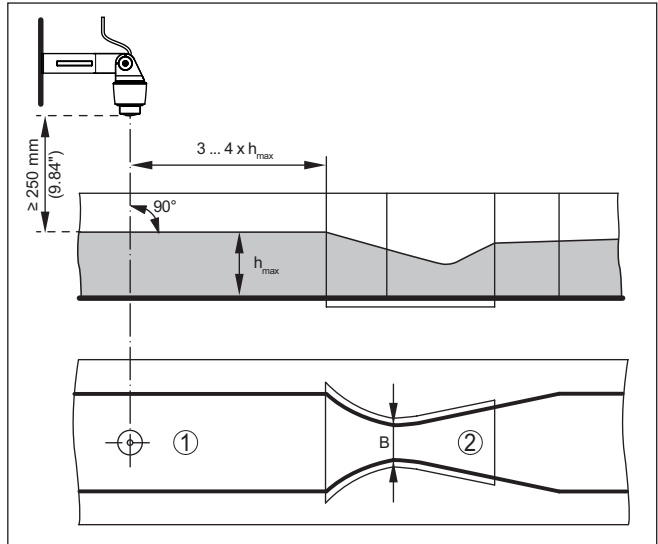

Fig. 25: Flow measurement with Khafagi-Venturi flume: $h_{max} = \text{max. filling of the flume}$; $B = \text{tightest constriction in the flume}$

- 1 Position sensor
- 2 Venturi flume

11.4.1 Setup

An application wizard guides you through the most common selection possibilities. Further application options are available on the corresponding DTM/app pages. A more detailed description of all available application options is included in the DTM online help.

The following steps must be carried out in the application wizard:

Select application

Select from the offered options the application "Flow measurement flume/Weir".

Assign measuring loop name

Assign a unique designation to the measuring point so that there can be no confusion with other measuring points.

Select sensor input

Define how the measured value should be transmitted between sensor and controller (4 ... 20 mA or HART). With HART selection, the desired sensor must also be selected. If HART is also available for the sensor, the HART selection should be used, as higher accuracy can be achieved here.

Define sensor characteristic values

When using analogue 4 ... 20 mA sensors, the measuring range suitable for the application should be set directly in the sensor to achieve maximum accuracy. This measuring range must now be stored once

again in the assistant together with the sensor type and the measuring unit.

When using HART sensors, only the desired sensor value with unit must be defined.

Define application

Select the appropriate linearization and flume type. A list of available flumes can be found in the introduction to this application.

Define adjustment values

Enter the adjustment values of the measuring point for 0 % and for 100 %.

Scaling

Enter the measured value and unit (e.g. flow rate in m³/h) and the corresponding scaling values for 100 % and 0 % (e.g. 100 m³/h, 0 m³/h).

Activate/define totalizer

The flow value can also be summed up and displayed as flow rate. Two independent totalizers are per measuring point available for this purpose. Define the measuring unit and the display format. In addition, a value for leak flow volume suppression can be defined.

Resetting the totalizer can be initiated as follows:

- via the display and adjustment module
- via the DTM/VEGA Tools app
- via a digital input (e.g. via button)
- time controlled (daily at any time)

Configure measured value indication

In the last step you can configure which and how many measured values are to be shown on the display. In addition, you can define the base of the display value, the display format and the optional bar graph.

12 Diagnostics and servicing

12.1 Maintenance

Maintenance

If the device is used properly, no special maintenance is required in normal operation.

Cleaning

The cleaning helps that the type label and markings on the instrument are visible.

Take note of the following:

- Use only cleaning agents which do not corrode the housings, type label and seals
- Use only cleaning methods corresponding to the housing protection rating

12.2 Rectify faults

Reaction when malfunction occurs

The operator of the system is responsible for taking suitable measures to rectify faults.

Causes of malfunction

The device offers maximum reliability. Nevertheless, faults can occur during operation. These may be caused by the following, e.g.:

- Measured value from sensor not correct
- Voltage supply
- Interference in the cables

Fault rectification

The first measures are:

- Evaluation of fault messages
- Checking the input/output signal

A smartphone/tablet with the VEGA Tools app or a PC/notebook with the software PACTware and the suitable DTM offer you further comprehensive diagnostic possibilities. In many cases, the causes can be determined in this way and the faults eliminated.

Reaction after fault rectification

Depending on the reason for the fault and the measures taken, the steps described in chapter "Setup" must be carried out again or must be checked for plausibility and completeness.

24 hour service hotline

Should these measures not be successful, please call in urgent cases the VEGA service hotline under the phone no. **+49 1805 858550**.

The hotline is also available outside normal working hours, seven days a week around the clock.

Since we offer this service worldwide, the support is provided in English. The service itself is free of charge, the only costs involved are the normal call charges.

12.3 Diagnosis, fault messages

Fault message

The controller and the connected sensors are permanently monitored during operation and the values entered during parameter adjustment are checked for plausibility. If irregularities occur or in case of

incorrect parameter adjustment, a fault signal is triggered. In case of an instrument defect or line break/shortcircuit, a fault signal is also triggered.

The fault indication lights up in case of failure and the current output as well as the relays react according to the configured fault mode. If the fail safe relay was configured, it will deenergize. In addition, one of the following error messages is outputted on the display and the background lighting changes to colour acc. to NAMUR NE 107 (e.g. red in case of a fault, orange in case of a function check).

Failure

Error code	Cause	Rectification
F002 no measuring point configured	Measuring point was not yet configured	No sensor assigned. For measuring point 3: No application with 3 measuring points was selected.
F003 Hardware: CRC error	CRC error (error with self-check)	Switch the instrument off/on Carry out a reset Send instrument for repair
F008 Sensor input: Failure, sensor	Sensor not found	Check connection of the sensor Check HART address of the sensor
F012 Sensor input: Hardware error	Hardware error, sensor input	Switch the instrument off and on Send instrument for repair
F013 Sensor input: Sensor error	The input of the measuring point returns an error The connected sensor returns an error	Switch device/sensor off and on Send device/sensor for repair
F014 Sensor input: Short-circuit	Sensor current > 21 mA or short-circuit	Check sensor, e.g. on fault signal Remove short-circuit
F015 Sensor input: Line break	Sensor in boot phase Sensor current < 3.6 mA or line break	Check sensor, e.g. on fault signal Remove line break Check connection of the sensor
F034 EEPROM: CRC error	EEPROM: CRC error	Switch the instrument off and on Carry out a reset Send instrument for repair
F035 ROM: CRC error	ROM: CRC error	Switch the instrument off and on Carry out a reset Send instrument for repair
F036 No operable software	No executable program Software update failed	Carry out another software update Send instrument for repair

Error code	Cause	Rectification
F037 RAM	RAM defective	Switch the instrument off and on Carry out a reset Send instrument for repair
F040 General hardware error	Hardware error	Switch the instrument off and on Carry out a reset Send instrument for repair

Out of specification

Error code	Cause	Rectification
S007 Sensor input: Type not compatible	Sensor type not compatible	Search for sensor again and allocate under " <i>Measuring point - Input</i> "
S016 Adjustment: Min./Max. exchanged	The min./max. adjustment points were exchanged.	Carry out the adjustment again, correct the min. and max. values.
S017 Adjustment: Span too small	Adjustment span too small	Carry out a fresh adjustment and increase the distance between min./max. adjustment
S021 Scaling: Span too small	Scaling span too small	Carry out a fresh scaling, increase the distance between min./max. scaling.
S022 Scaling: Scaling value too large	Value for one of the two scaling points is too large	Carry out the scaling again, correct the min. and max. values.
S030 Measured value not valid	The connected sensor is still in the start-up phase or is interrupted	Check sensor
S053 Sensor measuring range faulty	Sensor measuring range was not read correctly	Restart instrument
S062 Pulse priority too small	Pulse priority too small	Increase under " <i>Output</i> " the entry " <i>Pulse output all</i> " so that max. one pulse per second is output.
S104 Measurement loop deactivated	The measuring point is deactivated	Activate measuring point
S110 Relay: Span too small	Relay switching points too close together	Increase the difference between the two relay switching points

Error code	Cause	Rectification
S111 Relay: Switching points inter-changed	Relay switching points inter-changed	Change relay switching points for " On/ Off"
S115 Pump control: Faulty interference behaviour	Several relays are assignef to the pump control which are not set to the same failure mode	All relays which are assigned to the pump control must be set to the same failure mode
S116 Pump control: Operating mode faulty	Several relays that are not configured with the same mode are assigned to the pump control	All relays which are assigned to the pump control must be set to the same mode

Function check

Error code	Cause	Rectification
C029 Simulation	Simulation active	Finish simulation

Maintenance

Error code	Cause	Rectification
M083 Incorrect file access	Access to SD card faulty	Check SD card Format SD card Replace SD card
M085 SD card not inserted or formatted	SD card missing SD card not formatted	Insert SD card Format SD card
M117 Pump signals failure	Pump signals failure	Check faulty pump

12.4 Software update

An update of the device software is possible via the Bluetooth interface.

The following components are required:

- Instrument
- Voltage supply
- PC/Notebook with PACTware/DTM
- Current instrument software as file

You can find the current instrument software as well as detailed information on the procedure in the download area of our homepage.

**Caution:**

Instruments with approvals can be bound to certain software versions. Therefore make sure that the approval is still effective after a software update is carried out.

You can find detailed information in the download area on our homepage.

12.5 How to proceed if a repair is necessary

You can find an instrument return form as well as detailed information about the procedure in the download area of our homepage. By doing this you help us carry out the repair quickly and without having to call back for needed information.

In case of repair, proceed as follows:

- Print and fill out one form per instrument
- Clean the instrument and pack it damage-proof
- Attach the completed form and, if need be, also a safety data sheet outside on the packaging
- Ask the agency serving you to get the address for the return shipment. You can find the agency on our homepage.

13 Dismount

13.1 Dismounting steps

Take note of chapters "*Mounting*" and "*Connecting to voltage supply*" and carry out the listed steps in reverse order.

13.2 Disposal

The device is made of recyclable materials. For this reason, it should be disposed of by a specialist recycling company. Observe the applicable national regulations.

14 Certificates and approvals

14.1 Radio licenses

Bluetooth

The Bluetooth radio module in the device has been tested and approved according to the current edition of the applicable country-specific norms or standards.

The confirmations as well as regulations for use can be found in the document " *Radio licenses*" supplied or on our homepage.

14.2 Approvals for Ex areas

Approved versions for use in hazardous areas are available or in preparation for the device series.

You can find the relevant documents on our homepage.

14.3 Approvals as overfill protection

Approved versions for use as part of an overfill protection system are available or in preparation for this device series.

The corresponding approvals can be found on our homepage.

14.4 Metrological approvals

Approved versions, e.g. as certified measuring system for flow according to MCERTS, are available or in preparation for the device series.

Regulations for use can be found in the corresponding certificate on our homepage.

14.5 EU conformity

The device fulfils the legal requirements of the applicable EU directives. By affixing the CE marking, we confirm the conformity of the instrument with these directives.

The EU conformity declaration can be found on our homepage.

Electromagnetic compatibility

The instrument is designed for use in an industrial environment. Nevertheless, electromagnetic interference from electrical conductors and radiated emissions must be taken into account, as is usual with a class A instrument according to EN 61326-1. If the instrument is used in a different environment, its electromagnetic compatibility with other devices must be ensured by suitable measures.

14.6 Environment management system

Protection of the environment is one of our most important duties. That is why we have introduced an environment management system with the goal of continuously improving company environmental protection. The environment management system is certified according to DIN EN ISO 14001. Please help us fulfil this obligation by observ-

ing the environmental instructions in chapters "*Packaging, transport and storage*", "*Disposal*" of these operating instructions.

15 Supplement

15.1 Technical data

Note for approved instruments

The technical data in the respective safety instructions are valid for approved instruments (e.g. with Ex approval). In some cases, these data can differ from the data listed herein.

All approval documents can be downloaded from our homepage.

Materials and weights

Materials

- Housing	PC-FR
- Housing screws	StSt
- Inspection window	PE
- Seal	Silicone
- Cable glands	PA
- Sun shade	316L
- Brackets for tube mounting	V2A
Weight with mounting plate	1310 g (2.888 lbs)

Voltage supply

Operating voltage

- Nominal voltage AC	100 ... 230 V (-15 %, +10 %) 50/60 Hz
- Nominal voltage DC	24 ... 65 V (-15 %, +10 %)
Power consumption	max. 19 VA; 7 W

Sensor input

Number of sensors	2 x 4 ... 20 mA/HART
Type of input (selectable)	
- Active input	Sensor supply through VEGAMET 862
- Passive input	Sensor has an own voltage supply
Measured value transmission	
- 4 ... 20 mA	analogue for 4 ... 20 mA sensors
- HART protocol	digital for HART sensors
Deviation (4 ... 20 mA)	
- Accuracy	±20 µA (0.1 % of 20 mA)
Terminal voltage	27 ... 22 V at 4 ... 20 mA
Current limitation	approx. 26 mA
Internal resistance mode passive	< 250 Ω
Detection line break	≤ 3.6 mA
Detection shortcircuit	≥ 21 mA
Adjustment range 4 ... 20 mA sensor	
- Empty adjustment	2.4 ... 21.6 mA

– Full adjustment	2.4 ... 21.6 mA
Temperature error relating to 20 mA	0.008 %/K
Adjustment range HART sensor	± 10 % of sensor measuring range
Connection cable to the HART sensor	two-wire shielded standard cable

Digital input

Quantity	4 x digital input
Input type active	
– Voltage	14 ... 16 V DC
– Current	< 3 mA
– Max. load	200 Ω
Input type passive	
– Switching threshold Low	-3 ... 5 V DC
– Switching threshold High	11 ... 30 V DC
– Max. input voltage	30 V DC
– Max. input current	4 mA
– Max. sampling rate	10 Hz
– Input impedance	8 kΩ

Relay output

Quantity	6 x operating relay, one can be configured as fail safe relay
Function	Switching relay for level, fault signal or pulse relay for flow/sampling pulse, pump control
Contact	Floating spdt
Contact material	AgSnO ₂ , hard gold-plated
Switching voltage	max. 250 V AC/60 V DC
Switching current	max. 1 A AC (cos phi > 0.9), 1 A DC
Breaking capacity ⁴⁾	min. 50 mW, max. 250 VA, max. 40 W DC (with U < 40 V DC)
AC/DC operation	Mixed operation with AC/DC voltage is not permitted for the relay outputs
Min. programmable switching hysteresis	0.1 %
Mode pulse output	
– Pulse length	350 ms

Current output

Quantity	3 x output
Function	Level/flow/sampling pulse
Range	0/4 ... 20 mA, 20 ... 0/4 mA
Resolution	1 μA

⁴⁾ If inductive loads or stronger currents are switched through, the gold plating on the relay contact surface will be permanently damaged. The contact is then no longer suitable for switching low-level signal circuits.

Max. load	500 Ω
Fault signal (switch over)	0; < 3.6; 4; 20; 20.5; 22 mA
Accuracy	
– Standard	±20 µA (0.1 % of 20 mA)
– with EMC interferences	±80 µA (0.4 % of 20 mA)
Temperature error relating to 20 mA	0.005 %/K
Mode pulse output	
– Current pulse	20 mA
– Pulse length	200 ms

Bluetooth interface

Bluetooth standard	Bluetooth 5.0 (downward compatible to Bluetooth 4.0 LE)
Frequency	2.402 ... 2.480 GHz
Max. emitted power	+2.2 dBm
Max. number of participants	1
Effective range typ. ⁵⁾	25 m (82 ft)

Electromechanical data

Cable entry

– Cable gland (optional)	M20 x 1.5 (cable diameter 6 ... 12 mm)
– NPT adapter (optional)	M20 on ½ NPT
– Blind plug (optional)	M20 x 1.5

Connection terminals

– Type of terminal	Spring-loaded terminal
– Wire cross-section massive wire, strand	0.2 mm ² (AWG 26) ... 2.5 mm ² (AWG 12)
– Wire cross-section strand with end sleeve	0.25 mm ² ... 1.5 mm ²

Terminals digital input

– Type of terminal	Spring-loaded terminal
– Wire cross-section massive wire, strand	0.2 mm ² (AWG 26) ... 1.5 mm ² (AWG 16)
– Wire cross-section strand with end sleeve	0.25 mm ² ... 0.75 mm ²

Indicators

Measured value indication

– Graphic-capable LC display, with lighting	89 x 56 mm, digital and quasianalogue display
– Indication range	-9999999 ... 9999999

⁵⁾ Depending on the local conditions

LED displays

- | | |
|-----------------------------|------------|
| – Status, operating voltage | LED green |
| – Status fault signal | LED red |
| – Status, operating relay | LED yellow |

Status display via background lighting Colour signalling according to NAMUR NE 107 (red/orange/yellow/blue) or freely configurable

Adjustment

Adjustment elements	4 x keys for menu adjustment
PC/Notebook	PACTware/DTM
Smartphone/Tablet	VEGA Tools app

Memory card

Memory card type	microSDHC industrial
Capacity (supplied card)	8 GB
Capacitance (max.)	32 GB

Ambient conditions**Ambient temperature**

- | | |
|-------------------------|----------------------------------|
| – Instrument in general | -40 ... +60 °C (-40 ... +140 °F) |
| – Display (readability) | -20 ... +60 °C (-4 ... +140 °F) |

Storage and transport temperature -40 ... +80 °C (-40 ... +176 °F)

Relative humidity < 96 %

Mechanical environmental conditions

Vibrations (oscillations)	Class 4M8 acc. to IEC 60271-3-4 (5 g, 4 ... 200 Hz)
Impacts (mechanical shock)	Class 6M4 acc. to IEC 60721-3-6 (10 g/11 ms, 30 g/6 ms, 50 g/2.3 ms)

Electrical protective measures

Protection rating	IP66/IP67 acc. to IEC 60529, Type 4X acc. to UL 50
Altitude above sea level	up to 5000 m (16404 ft)
Overvoltage category (IEC 61010-1)	II
Protection class	I
Pollution degree	4

Protection against dangerous body currents

Reliable separation according to IEC/EN 61140 by reinforced insulation according to IEC/EN 61010 part 1 up to 253 V AC/DC with overvoltage category II and fulfilled enclosure protection class between the supply, signal and relay circuits.

Sensor inputs (active) are energy limited circuits according to IEC/UL 61010 part 1.

15.2 Overview applications/functionality

The following charts provide an overview of the standard applications and functions of VEGAMET

800 series controllers. They give also information about whether the respective function can be activated and adjusted via the integrated indicating and adjustment unit (OP) or via DTM/app.⁶⁾

Applications (adjustable with DTM/app)	VEGAMET				Adjustment	
	841	842	861	862	OP	DTM/ App
Universal	•	•	•	•	•	•
Level storage tank	•	•	•	•		•
Calculation difference		•		•		•
Calculation total		•		•		•
Calculation of average value		•		•		•
Wells	•	•	•	•		•
Pumping station	•	•	•	•		•
Sewage screw lifting station	•	•	•	•		•
Screen control		•		•		•
Flow measurement flume/weir	•	•	•	•		•
Pressurized vessel		•		•		•

Additional application examples	VEGAMET				Adjustment	
	841	842	861	862	OP	DTM/ App
Level measurement	•	•	•	•		•
Gauge measurement	•	•	•	•		•
Process pressure measurement	•	•	•	•		•
Overflow basin		•		•		•
Density		•		•		•

Functions	VEGAMET				Adjustment	
	841	842	861	862	OP	DTM/ App
Application wizard	•	•	•	•		•
Indication measured values	•	•	•	•	•	•
Automatic display change	•	•	•	•	•	•
Display multilingual	•	•	•	•	•	•
Sensor input 4 ... 20 mA	•	•	•	•	•	•
Sensor input HART			•	•	•	•
Damping	•	•	•	•	•	•
Linearization - preset curves	•	•	•	•	•	•
Linearization - Dimensions ISO standard	•	•	•	•		•
Linearization - Flow formula	•	•	•	•		•

⁶⁾ OP: Operating Panel (integrated display and adjustment unit)

Functions	VEGAMET				Adjustment	
	841	842	861	862	OP	DTM/ App
Linearization - Manufacturer definition	•	•	•	•		•
Linearization - Calculation wizard	•	•	•	•		•
Linearization - Bearing table	•	•	•	•		•
Linearization - Gauging by litres	•	•	•	•		•
Linearization curves - Import	•	•	•	•		•
Adjustment of the measuring point	•	•	•	•	•	•
Scaling	•	•	•	•	•	•
Totalizer 1/2	•	•	•	•		•
Totalizer 3/4/5/6		•		•		•
Reset totalizer via digital input		•		•		•
Relay mode - Overfill protection	•	•	•	•	•	•
Relay mode - Dry run protection	•	•	•	•	•	•
Relay mode - Switching window ON	•	•	•	•		•
Relay mode - Switching window OFF	•	•	•	•		•
Relay mode - Flow rate pulse	•	•	•	•		•
Relay mode - Sampling pulse	•	•	•	•		•
Relay mode - Rising tendency	•	•	•	•		•
Relay mode - Falling tendency	•	•	•	•		•
Relay mode - Pump control 1 (same running time)	•	•	•	•		•
Relay mode - Pump control 2 (same running time)	•	•	•	•		•
Relay mode - Pump control 3 (fixed sequence)	•	•	•	•		•
Relay mode - Pump control 4 (fixed sequence)	•	•	•	•		•
Mode - Pump control - Sequenced operation	•	•	•	•		•
Mode - Pump control - Alternating pump operation	•	•	•	•		•
Dry weather pump	•	•	•	•		•
Pump monitoring via digital input			•	•		•
Forced pump changeover	•	•	•	•		•
Relay switch on and off delay	•	•	•	•		•
Bandwidth for switching points	•	•	•	•		•
Fail safe relay	•	•	•	•	•	•
Current output 0/4 ... 20 mA, 20 ... 4 mA	•	•	•	•	•	•
Current output - Flow rate pulse	•	•	•	•		•
Current output - Sampling pulse	•	•	•	•		•
Diagnosis - Status	•	•	•	•	•	•
Diagnosis - Measured values	•	•	•	•	•	•
Simulation - Sensor value, %, lin% value, scaled values	•	•	•	•	•	•

Functions	VEGAMET				Adjustment	
	841	842	861	862	OP	DTM/ App
Simulation - current output	•	•	•	•		•
Simulation - relay output	•	•	•	•		•
Simulation - digital input			•	•		•
Date/Time			•	•	•	•
Internal device memory/SD card			•	•	•	•
Protection of the parameterization	•	•	•	•	•	•
Bluetooth access code	•	•	•	•	•	•
Activate/deactivate Bluetooth communication	•	•	•	•	•	

15.3 Dimensions

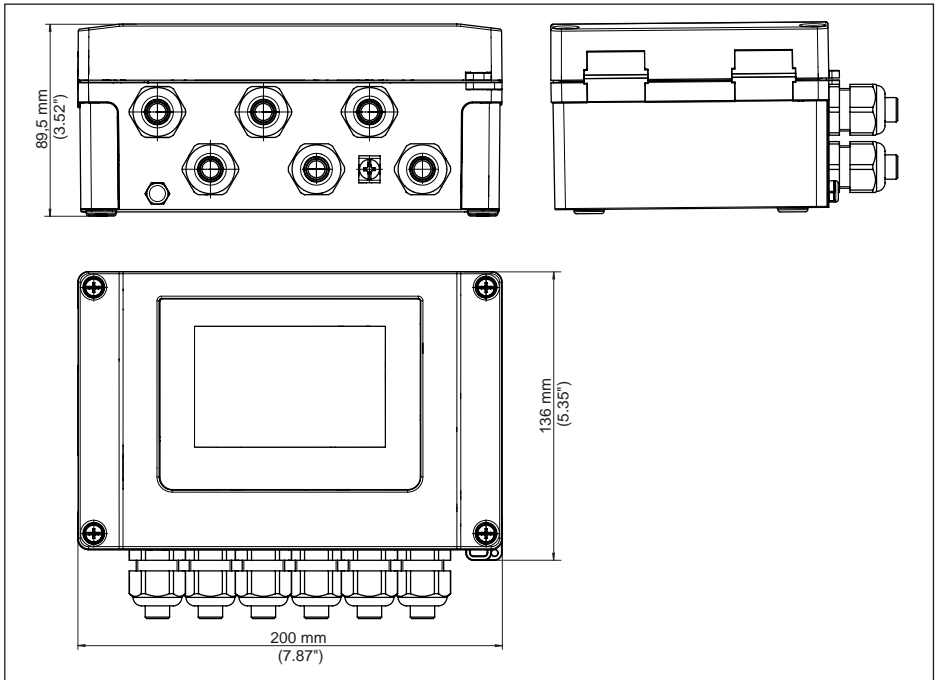

Fig. 26: Dimensions VEGAMET 862

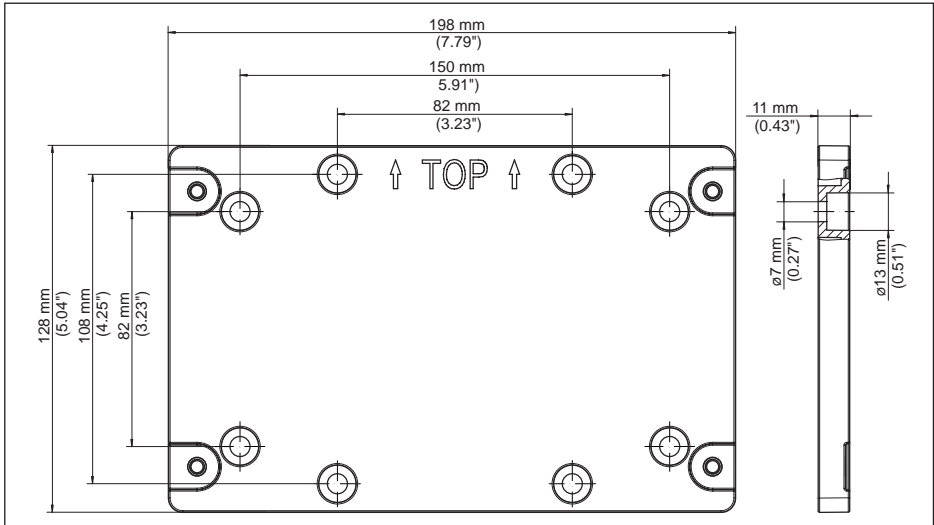

Fig. 27: Dimensions mounting plate

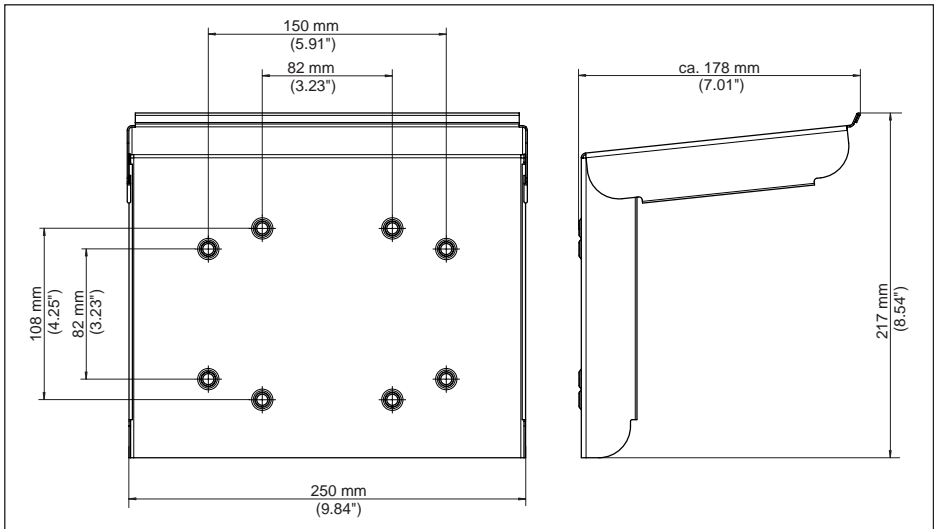

Fig. 28: Dimensions sun shade

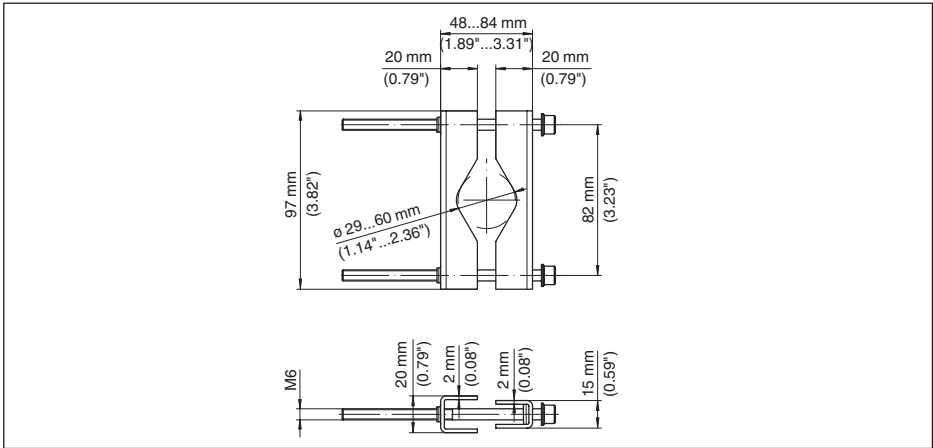

Fig. 29: Dimensions Brackets for tube mounting

15.4 Industrial property rights

VEGA product lines are global protected by industrial property rights. Further information see www.vega.com.

VEGA Produktfamilien sind weltweit geschützt durch gewerbliche Schutzrechte.

Nähere Informationen unter www.vega.com.

Les lignes de produits VEGA sont globalement protégées par des droits de propriété intellectuelle. Pour plus d'informations, on pourra se référer au site www.vega.com.

VEGA líneas de productos están protegidas por los derechos en el campo de la propiedad industrial. Para mayor información revise la pagina web www.vega.com.

Линии продукции фирмы ВЕГА защищаются по всему миру правами на интеллектуальную собственность. Дальнейшую информацию смотрите на сайте www.vega.com.

VEGA系列产品在全球享有知识产权保护。

进一步信息请参见网站 < www.vega.com。

15.5 Licensing information for open source software

Open source software components are also used in this device. A documentation of these components with the respective license type, the associated license texts, copyright notes and disclaimers can be found on our homepage.

15.6 Trademark

All the brands as well as trade and company names used are property of their lawful proprietor/originator.

INDEX

A

- Access protection 30
- Adjustment 27
 - Max. adjustment 28
 - Min. adjustment 28
- Application area 9

B

- Bluetooth 30
 - Bluetooth access code 30

C

- Cable
 - Grounding 15
 - Potential equalisation 15
 - Shielding 15
- Causes of malfunction 57
- Current output 29

D

- Damping 27
- Data logger 37
- Date setting 31
- Deactivate measuring point 27
- Default setting 31
- Device info 31
- Device-TAG 31
- Device trend 37
- Diagnostics 31
- Documentation 8
- Dry run protection 28, 40
- DTM 22, 25, 28

E

- Electrical connection 16

F

- Fail safe relay 30
- Fault 29
 - Fail safe relay 28, 29
 - Fault message 31, 57
 - Rectification 57
- Fault rectification 57
- Flow measurement 22, 28, 53
 - Khafagi-Venturi flume 55
 - Rectangular overflow 54
- Fluctuating medium surface 27
- Flume 53
- Functional principle 9

H

- HART communication 22
- HART resistance 22
- Horizontal cylindrical tank 27
- Hysteresis 43

I

- Indication
 - Background lighting 29
 - Backlight 29
 - Brightness 29
 - Contrast 29
 - Language adjustment 29
 - Measured value indication 29
 - Measured value indications Display 29
- Input 27
 - 4 ... 20 mA 26
 - Active 16
 - HART 26
 - Passive 16
- Integration time 27

L

- Language adjustment 29
- Level measurement 40
- Linearisation 27
- Linearisation curve 27, 40
- Line break 58

M

- Main menu 26
- Memory card
 - SD card 31
- Mounting 14
 - Tube 13
 - Wall mounting 12

O

- Overflow protection 28, 40

P

- PACTware 22, 25, 28
- Palmer-Bowlus flume 53
- Parameter adjustment 25
- PIN 30
- Potential equalisation 15
- Primary Value 26
- Pump control 45, 48
- Pumping station 43

Q

QR code 8

R

Rectangular overfall 53

Relay 59

Relay output 28

– Fail safe relay 29, 57

Repair 61

Reset 31

S

Scaling 28, 40

Screen control 51

Secondary Value 26

Sensor input

– Active 16

– Passive 16

Serial number 8

Service hotline 57

Short-circuit 58

Simulation 31

Spherical tank 27

Storage tank 40

Sun shade 14

Switching window 28

T

Tendency 28

Time setting 31

Trapezoidal weir 53

Triangular overfall 53

Type label 8

V

VEGA Tools app 22

Venturi flume 53

V-Notch 53

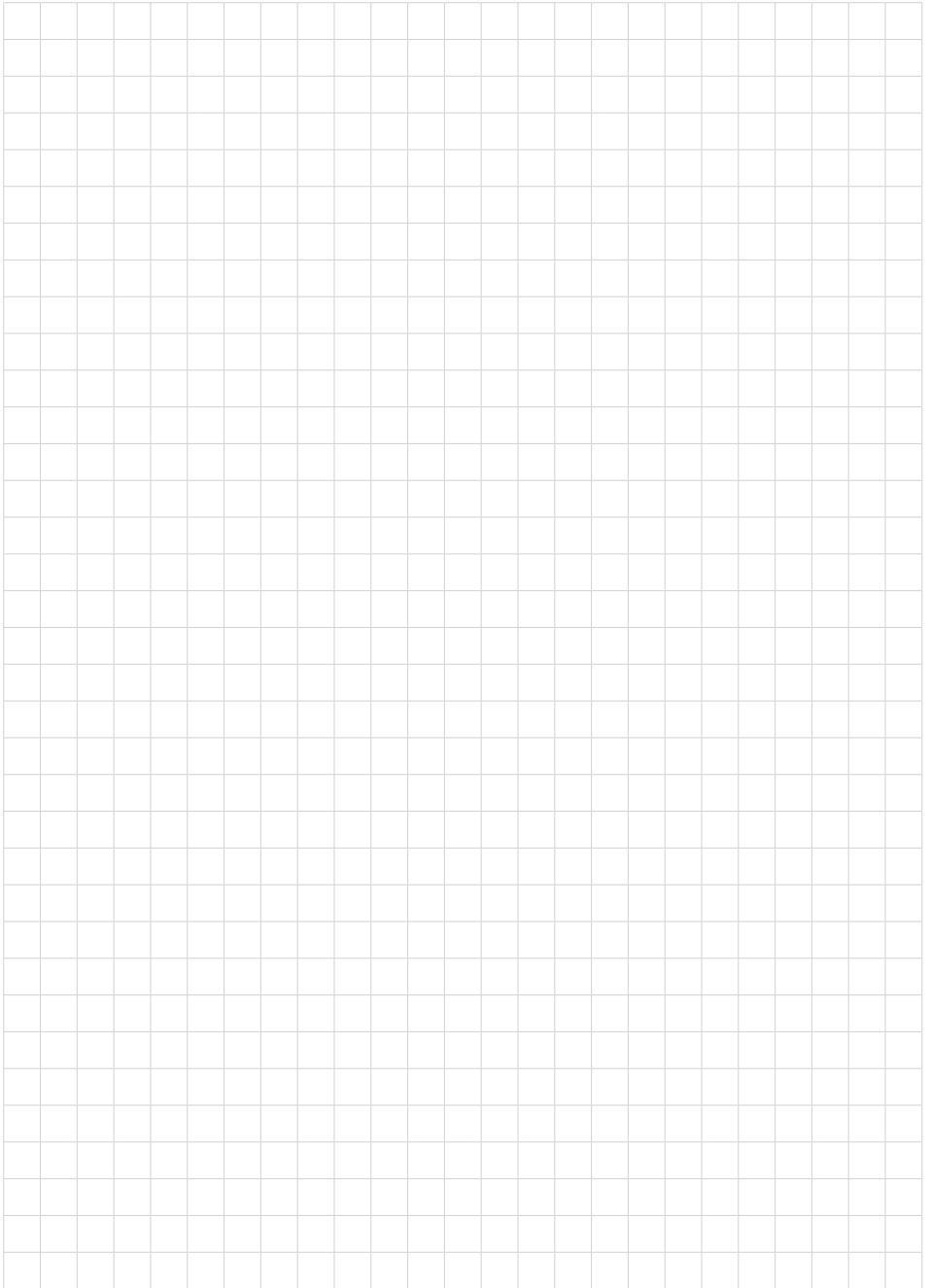



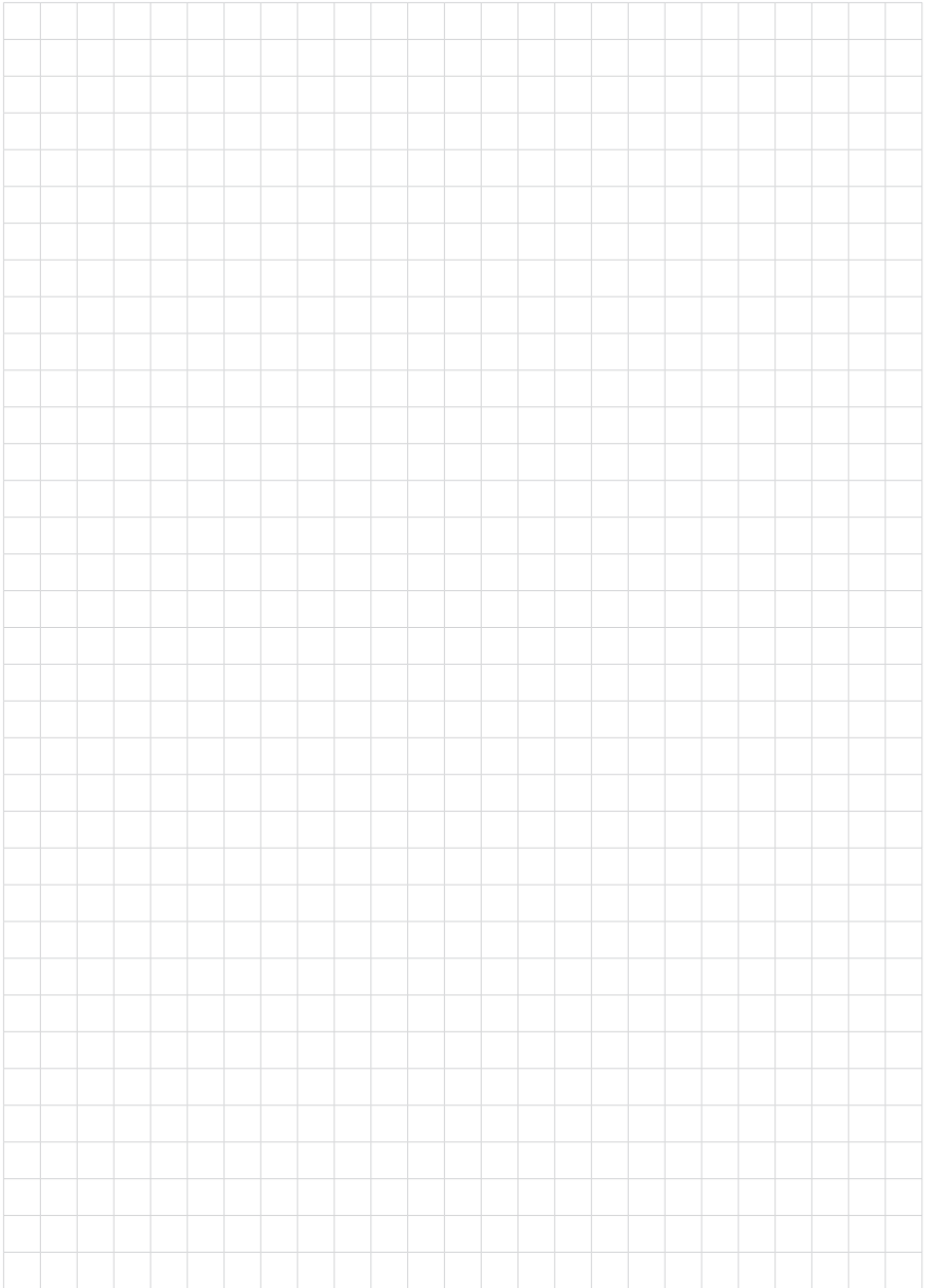

Printing date:

VEGA

All statements concerning scope of delivery, application, practical use and operating conditions of the sensors and processing systems correspond to the information available at the time of printing.

Subject to change without prior notice

© VEGA Grieshaber KG, Schiltach/Germany 2021



58867-EN-210818

VEGA Grieshaber KG
Am Hohenstein 113
77761 Schiltach
Germany

Phone +49 7836 50-0
E-mail: info.de@vega.com
www.vega.com