

# EXtract 810M stainless steel



- » Robust design, integrated scraper
- » Automatic locking system with indicators for measurement- and service position
- » Automatic safety lock while sensor is removed
- » Stainless steel AISI 316L / 1.4404 or Alloy
- » Immersion length up to 107mm
- » Usable in ATEX-areas
- » High variation of process connections and sealing materials

EXtract 810M is a manually operated retractable probe housing made of stainless steel for installation of Ø12mm sensors on tanks or pipelines with an unique rotary drive unit.

## Specifications

Process pressure:	0...16 bar
Process temperature:	-10...140 °C
Ambient temperature:	-10...70 °C
Immersion length:	up to 107 mm
Sensors:	225 mm Ø12 PG13.5
Materials:	stainless steel 1.4404 /316L, Alloy C22 (2.4602)
Sealings:	EPDM, FPM (Viton), FFKM (Kalrez)
Process connection:	Flange DN32 / DN40 / DN50 / ANSI 1 ¼" / ANSI 1 ½" / ANSI 2", MNPT 1 ¼", TriClamp 1-1.5", TriClamp 2"
Cleaning ports:	G1/8", G1/4", FNPT1/4"
Operating power:	manual rotary drive unit
Limit switches:	optional electrical NAMUR switches

## Dimensions

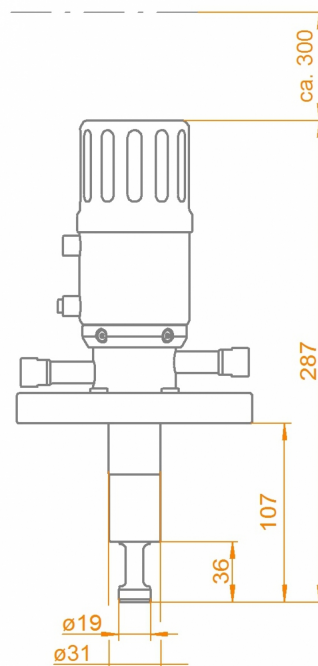

# EXtract 810M stainless steel



Process parts with sensor in measuring position



Unlocking pins and position indicators on manual drive unit

## Order code

Code	Material (wetted parts)	Delivery time
4404	Stainless steel 1.4404 / 316L	2 Weeks
HC22	Alloy C22 2.4602	4 Weeks

Code	Sealing material (wetted sealings)	Delivery time
EPD	EPDM/FDA/USP VI	2 Weeks
FPM	FPM (Viton)	2 Weeks
FKM	FFKM (Kalrez)	3 Weeks

Code	Sensor type	Delivery time
225	225mm PG 13,5 gel-filled	2 Weeks
280	280mm PG 13,5 liquid filled	2 Weeks

Code	Process connection	Delivery time
D32	Flange DN32 PN16	2 Weeks
D40	Flange DN40 PN16	2 Weeks
D50	Flange DN50 PN16	2 Weeks
A14	Flange ANSI 1 1/4" 150lbs	2 Weeks
A12	Flange ANSI 1 1/2" 150lbs	2 Weeks
A20	Flange ANSI 2" 150lbs	2 Weeks
N14	NPT M 1 1/4"	2 Weeks
T15	TriClamp 1-1,5" (OD Ø50.5mm)	2 Weeks
T20	TriClamp 2.0 (OD Ø64mm)	2 Weeks

Code	Cleaning connection	Delivery time
G18	G 1/8" female thread	2 Weeks
G14	G 1/4" female thread	2 Weeks
N14	1/4" NPT female thread	2 Weeks

Code	Position switch	Delivery time
00	without	2 Weeks